

T.I.P.: R-5021

CONTRACT: C204123

**STATE OF NORTH CAROLINA
DEPARTMENT OF TRANSPORTATION**

**PAVEMENT MARKING PLAN
BRUNSWICK COUNTY**

TIP NO. R-5021	SHEET NO. PMP-1
<small>Designed by:</small> APPROVED: <u>Andrew D. Klinksiek</u> <small>E3078FB498E44B</small>	
DATE: 9/2/2021	
SEAL 	
DOCUMENT NOT CONSIDERED FINAL UNLESS ALL SIGNATURES COMPLETED	

INDEX

SHEET NO.	DESCRIPTION
PMP-1	PAVEMENT MARKING PLAN TITLE SHEET
PMP-1A	PAVEMENT MARKING SCHEDULE AND LEGEND
PMP-1B	PAVEMENT MARKING PLAN KEY SHEET
PMP-2-2A	PAVEMENT MARKING CROSSWALK GUIDANCE DETAILS
PMP-2B-2C	REVISED ROADWAY STANDARD DRAWINGS
PMP-3-36	PAVEMENT MARKING DETAILS

ROADWAY STANDARD DRAWING

THE FOLLOWING ROADWAY STANDARDS AS APPEAR IN "ROADWAY STANDARD DRAWINGS" - CONTRACT STANDARDS AND DEVELOPMENT UNIT - N.C. DEPARTMENT OF TRANSPORTATION - RALEIGH, N.C., DATED JANUARY 2018 ARE APPLICABLE TO THIS PROJECT AND BY REFERENCE HEREBY ARE CONSIDERED A PART OF THESE PLANS:

STD. NO.	TITLE
1205.01	PAVEMENT MARKINGS - LINE TYPES AND OFFSETS
1205.02	PAVEMENT MARKINGS - TWO-LANE AND MULTILANE ROADWAYS
1205.03	PAVEMENT MARKINGS - EXIT AND ENTRANCE RAMP
1205.04	PAVEMENT MARKINGS - INTERSECTIONS (SHEET 1 OF 2) (SEE SHEET PMP-2B FOR SHEET 2 OF 2)
1205.05	PAVEMENT MARKINGS - TURN LANES
1205.06	PAVEMENT MARKINGS - LANE DROPS
1205.07	PAVEMENT MARKINGS - PEDESTRIAN CROSSWALKS (REPLACED WITH SHEETS PMP-2 AND PMP-2A IN PLANS.)
1205.08	PAVEMENT MARKINGS - SYMBOLS AND WORD MESSAGES
1205.09	PAVEMENT MARKINGS - PAINTED ISLANDS
1205.12	PAVEMENT MARKINGS - BRIDGES (SEE SHEET PMP-2C)
1205.13	PAVEMENT MARKINGS - LANE REDUCTIONS
1205.15	PAVEMENT MARKINGS - SUPERSTREETS
1250.01	RAISED PAVEMENT MARKERS - INSTALLATION SPACING
1251.01	RAISED PAVEMENT MARKERS - PERMANENT AND TEMPORARY
1253.01	RAISED PAVEMENT MARKERS - SNOWPLOWABLE
1261.01	GUARDRAIL AND BARRIER DELINEATORS - INSTALLATION SPACING
1261.02	GUARDRAIL AND BARRIER DELINEATORS - TYPES AND MOUNTING
1262.01	GUARDRAIL END DELINEATION
1264.01	OBJECT MARKERS - TYPES
1264.02	OBJECT MARKERS - INSTALLATION
1266.01	RAISED PAVEMENT MARKERS - TUBULAR MARKERS
1267.01	FLEXIBLE DELINEATORS - INSTALLATION
1267.02	FLEXIBLE DELINEATORS - SPACING TABLES
1267.03	FLEXIBLE DELINEATORS - INTERCHANGE PLACEMENT

REVISED ROADWAY STANDARD DRAWING

THE FOLLOWING ROADWAY STANDARDS AS APPEAR IN "ROADWAY STANDARD DRAWINGS" - CONTRACT STANDARDS AND DEVELOPMENT UNIT - N.C. DEPARTMENT OF TRANSPORTATION - RALEIGH, N.C., DATED JANUARY 2018 ARE APPLICABLE TO THIS PROJECT AND BY THE FOLLOWING REVISED ROADWAY STANDARD IS USED ON THIS PROJECT:

STD. NO.	TITLE	SHEET NO.
1205D04	INTERSECTIONS (SHEET 2 OF 2)	PMP-2B
1205D12	PAVEMENT MARKINGS - BRIDGES	PMP-2C

GENERAL NOTES

THE FOLLOWING GENERAL NOTES APPLY AT ALL TIMES FOR THE DURATION OF THE CONSTRUCTION PROJECT, EXCEPT WHEN OTHERWISE NOTED IN THE PLAN, OR DIRECTED BY THE ENGINEER.

A) INSTALL PAVEMENT MARKINGS AND PAVEMENT MARKERS ON THE FINAL SURFACE AS FOLLOWS:

ROAD NAME	MARKING	MARKER
-L- NC 211	-YA-	
-Y14A- NC 133	-YB-	THERMOPLASTIC
-Y22- NC 87	-Y14C-	
-YREV- NC 906	-Y14D-	
-Y1-	-Y7-	-Y14E-
-Y1A-	-Y8-	-Y14F-
-Y1C-	-Y9-	-Y14G-
-Y2-	-Y9A-	-Y15-
-Y2A-	-Y10-	-Y16-
-Y3-	-Y11-	-Y17-
-Y4-	-Y12-	-Y18REV-
-Y5-	-Y13-	-Y19REV-
-Y6-	-Y14-	-Y20-
CONCRETE BRIDGE DECKS	POLYUREA	RAISED

B) TIE PROPOSED PAVEMENT MARKING LINES TO EXISTING PAVEMENT MARKING LINES.

C) REMOVE/REPLACE ANY CONFLICTING/DAMAGED PAVEMENT MARKINGS AND MARKERS.

D) PASSING ZONES WILL BE DETERMINED IN THE FIELD AND MUST BE APPROVED BY THE ENGINEER.

E) STOP BAR LOCATION AT NON-SIGNALIZED INTERSECTIONS MAY BE ADJUSTED AS DIRECTED BY THE ENGINEER.

F) REMOVE ALL RESIDUE AND SURFACE LAITANCE BY ACCEPTABLE METHODS ON CONCRETE BRIDGE DECKS PRIOR TO PLACING (POLYUREA) PAVEMENT MARKING MATERIAL.

G) UNLESS OTHERWISE SPECIFIED, HEATED-IN-PLACE THERMOPLASTIC MAY BE USED IN LIEU OF EXTRUDED THERMOPLASTIC FOR STOP BARS, SYMBOLS, CHARACTERS AND DIAGONALS. IF HEATED-IN-PLACE IS USED, IT SHALL BE PAID FOR USING THE EXTRUDED THERMOPLASTIC PAY ITEM.

H) SEE ROADWAY PLANS FOR ALTERNATE CURB RAMP DESIGNS WHEN INDICATED ON PAVEMENT MARKING DETAIL SHEETS.

PLANS REVIEWED BY: N.C.D.O.T. SIGNING AND DELINEATION UNIT

Jessi Leonard, PE DIVISION TRAFFIC ENGINEER
R. Coke Gray III, PE REGIONAL TRAFFIC ENGINEER

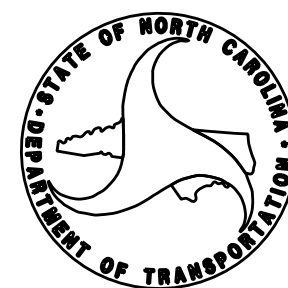

PLAN PREPARED BY: HNTB NORTH CAROLINA, P.C.

A.D. Klinksiek, PE, PTOE PROJECT ENGINEER
Jenifer Phillips DESIGN TECHNICIAN

HNTB HNTB NORTH CAROLINA, P.C.
 343 E. Six Forks Road, Suite 200
 Raleigh, North Carolina 27609
 NC License No: C-1554
 (919) 546-8997

TIP NO. R-5021	SHEET NO. PMP-1A
APPROVED: <i>Andrew D. Klinck</i> E3078F84596E44B	
DATE: 10/28/2021	
	
DOCUMENT NOT CONSIDERED FINAL UNLESS ALL SIGNATURES COMPLETED	



FINAL PAVEMENT MARKING SCHEDULE

MATERIAL	SYMBOL	DESCRIPTION
PAVEMENT MARKING		
THERMOPLASTIC (4", 90 MILS)		
TA		WHITE EDGELINE
TB		YELLOW EDGELINE
T8		2 FT.-6 FT./SP WHITE MINISKIP
T9		2 FT.-6 FT./SP YELLOW MINISKIP
TC		10 FT. WHITE SKIP
TD		3 FT.-9 FT./SP WHITE MINISKIP
TE		WHITE SOLID LANE LINE
TF		10 FT. YELLOW SKIP
TH		YELLOW SINGLE CENTER
TI		YELLOW DOUBLE CENTER
THERMOPLASTIC (8", 90 MILS)		
TN		WHITE GORELINE
TO		WHITE DIAGONAL
T13		3 FT.-9 FT./SP WHITE MINISKIP
T17		3 FT.-3 FT./SP WHITE MINISKIP
TR		WHITE SOLID LANE LINE
THERMOPLASTIC (12", 90 MILS)		
TT		WHITE SOLID LANE LINE
TU		WHITE DIAGONAL
TV		YELLOW DIAGONAL
THERMOPLASTIC (24", 90 MILS)		
T2		WHITE STOPBAR
T3		WHITE CROSSWALK LINE
POLYUREA (4", 20 MILS)		
VA		WHITE EDGELINE
VB		YELLOW EDGELINE
VC		10 FT. WHITE SKIP
POLYUREA (8", 20 MILS)		
V13		3 FT.-9 FT./SP WHITE MINISKIP

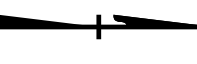

THERMOPLASTIC PAVEMENT MARKING SYMBOLS (90 MILS)	
UA	LEFT TURN ARROW
UB	RIGHT TURN ARROW
UC	STRAIGHT ARROW
UD	COMBO STRAIGHT/LEFT
UE	COMBO STRAIGHT/RIGHT
UM	12" YIELD LINE TRIANGLE
UN	24" YIELD LINE TRIANGLE
UP	MERGE ARROW
UQ	RAMP ARROW
UT	U-TURN ARROW
UU	FISH-HOOK STRAIGHT ARROW
UW	FISH-HOOK RIGHT/STRAIGHT ARROW
YA	FISH-HOOK W/CIRCLE LEFT ARROW
YB	FISH-HOOK W/CIRCLE LEFT/STRAIGHT ARROW
YE	ELONGATED STRAIGHT ARROW
THERMOPLASTIC PAVEMENT MARKING CHARACTER (90 MILS)	
UI	ALPHANUMERIC CHAR.
RAISED PAVEMENT MARKERS (NOT SHOWN)	
MA	YELLOW & YELLOW
MB	CRYSTAL & RED
SNOWPLOWABLE PAVEMENT MARKERS (NOT SHOWN)	
ME	YELLOW & YELLOW
MF	CRYSTAL & RED

LEGEND





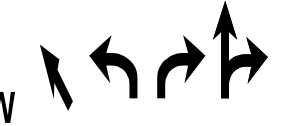









GENERAL

 DIRECTION OF TRAFFIC FLOW
 NORTH ARROW
 PROPOSED PVMT.  EXIST. PVMT.

PAVEMENT MARKINGS

 PAVEMENT MARKING SYMBOLS
 ONLY PAVEMENT MARKING CHARACTERS

PAVEMENT MARKING SYMBOLS

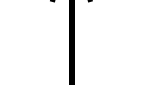
	UA		UT
	UB		UU
	UC		UW
	UD		YA
	UE		YB
ONLY	UI		YE
	UM		
	UN		
	UP		
	UQ		

10/28/2021
 V:\PMP\5021_PMP_01-01A.dgn
 HNTB

HNTB
HNTB NORTH CAROLINA, P.C.
 343 E. SIX FORKS ROAD, SUITE 200
 RALEIGH, NORTH CAROLINA 27609
 NC License No: C-1554
 (919) 546-8997

PAVEMENT MARKING SCHEDULE AND LEGEND

TIP NO. R-5021	SHEET NO. PMP-1B
APPROVED: <i>Andrew D. Klincksiek</i> E3078FB4596E48	
DATE: 10/28/2021	
	
DOCUMENT NOT CONSIDERED FINAL UNLESS ALL SIGNATURES COMPLETED	

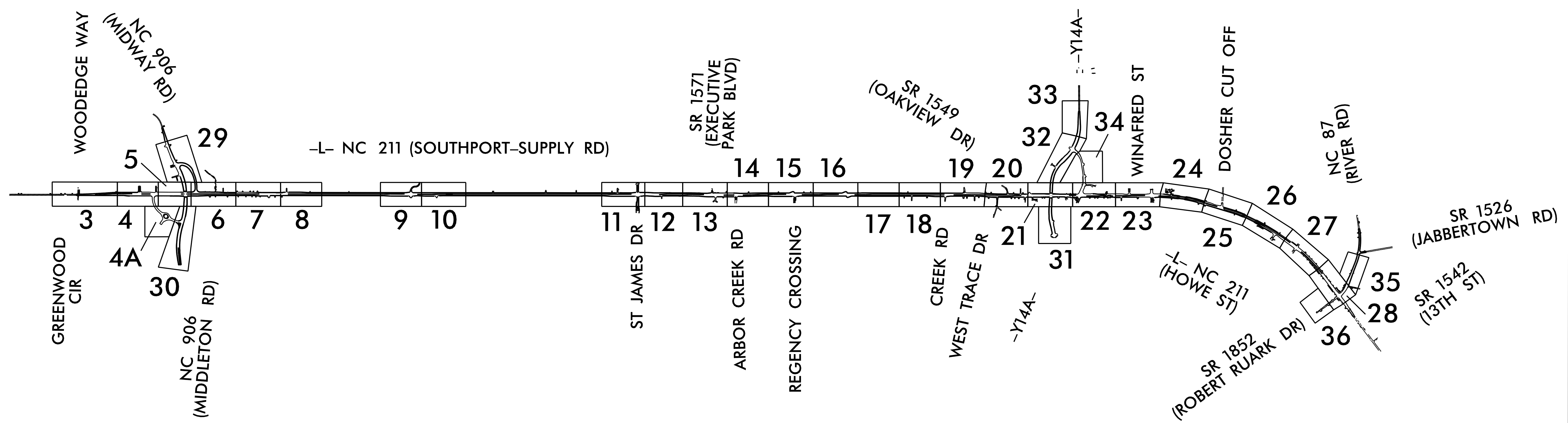

10/28/2021
 I:\PMP\R5021_PMP_01B.dgn
 HNTB

HNTB

HNTB NORTH CAROLINA, P.C.
 343 E. Six Forks Road, Suite 200
 Raleigh, North Carolina 27609
 NC License No: C-1554
 (919) 546-8997

**PAVEMENT MARKING PLAN
KEY SHEET**

TIP NO. R-5021	SHEET NO. PMP-1B
Approved by: <i>Andrew D. Klinkosiek</i> <small>E3078FB498E44B...</small>	
DATE: 9/2/2021	
	
DOCUMENT NOT CONSIDERED FINAL UNLESS ALL SIGNATURES COMPLETED	

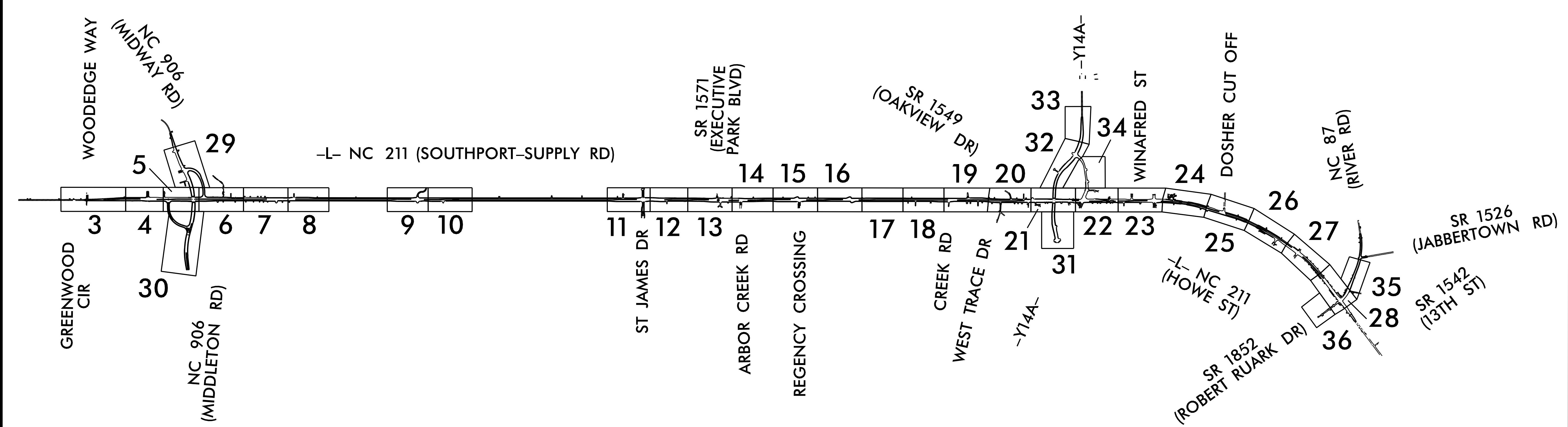

9/2/2021
 P:\PMP\R5021_PMP_pmp_01B.dgn
 HNTB

HNTB

HNTB NORTH CAROLINA, P.C.
 343 E. Six Forks Road, Suite 200
 Raleigh, North Carolina 27609
 NC License No: C-1554
 (919) 546-8997

**PAVEMENT MARKING PLAN
KEY SHEET**

TIP NO. R-5021	SHEET NO. PMP-2
APPROVED: <i>Andrew D. Klinkosiek</i> E3078FB498644B	
DATE: 9/2/2021	
SEAL 	
DOCUMENT NOT CONSIDERED FINAL UNLESS ALL SIGNATURES COMPLETED	

ALL SIGNALIZED PEDESTRIAN CROSSWALKS SHALL BE SPECIAL EMPHASIS CROSSWALKS AS SPECIFIED IN NCDOT DIVISION 3 HIGH-VISIBILITY CROSSWALK POLICY.

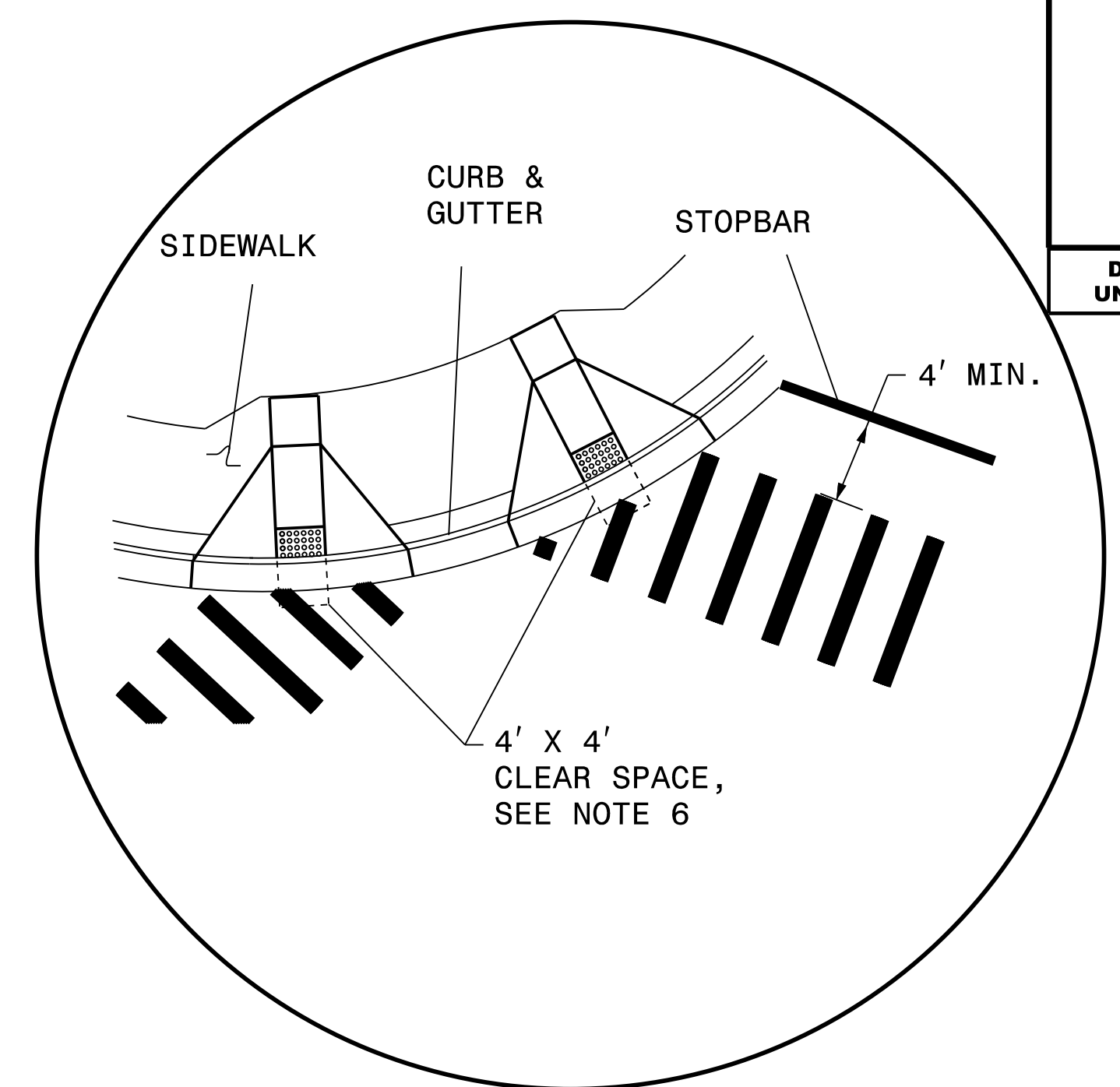
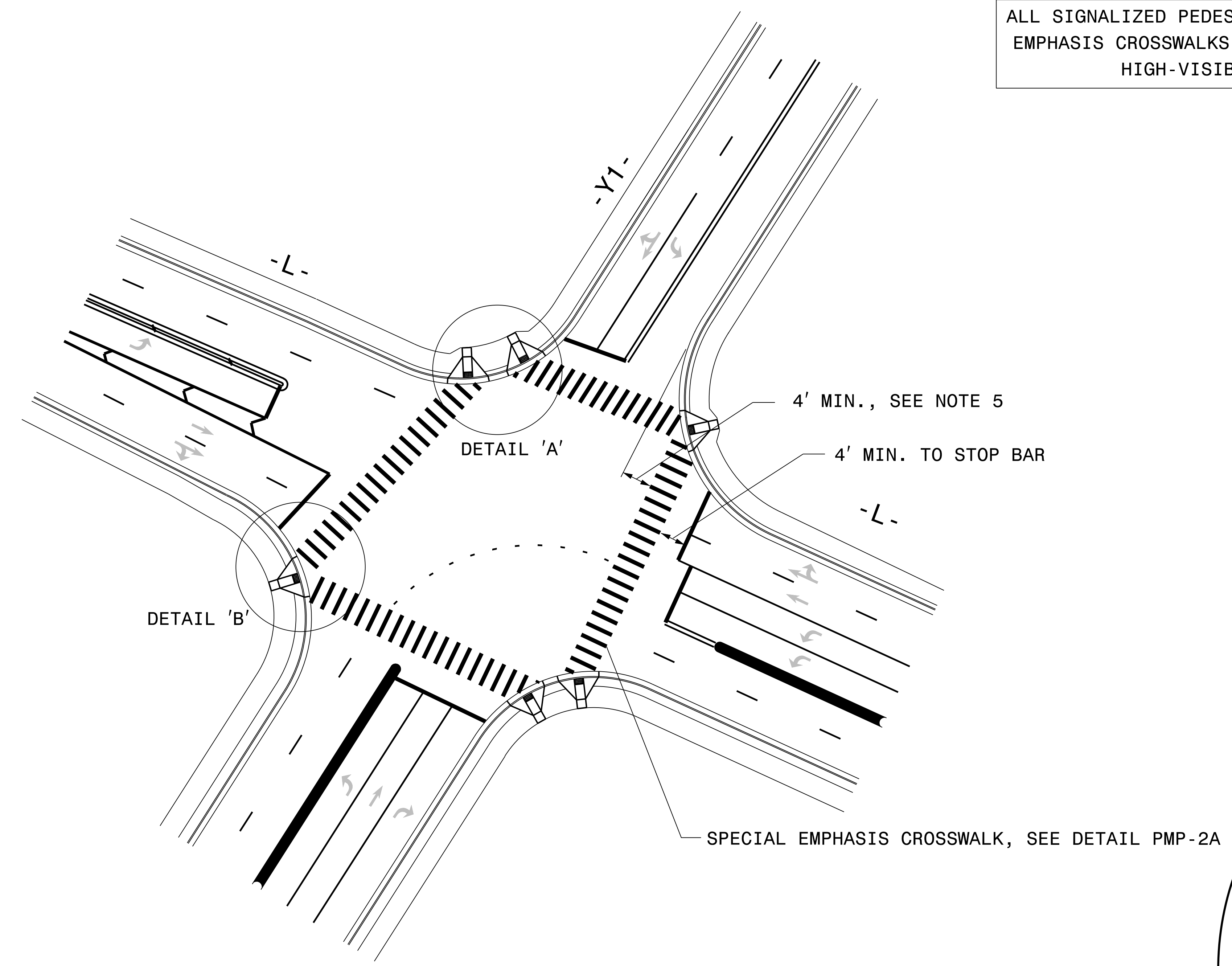

DETAIL 'A'- DUAL CURB RAMPS

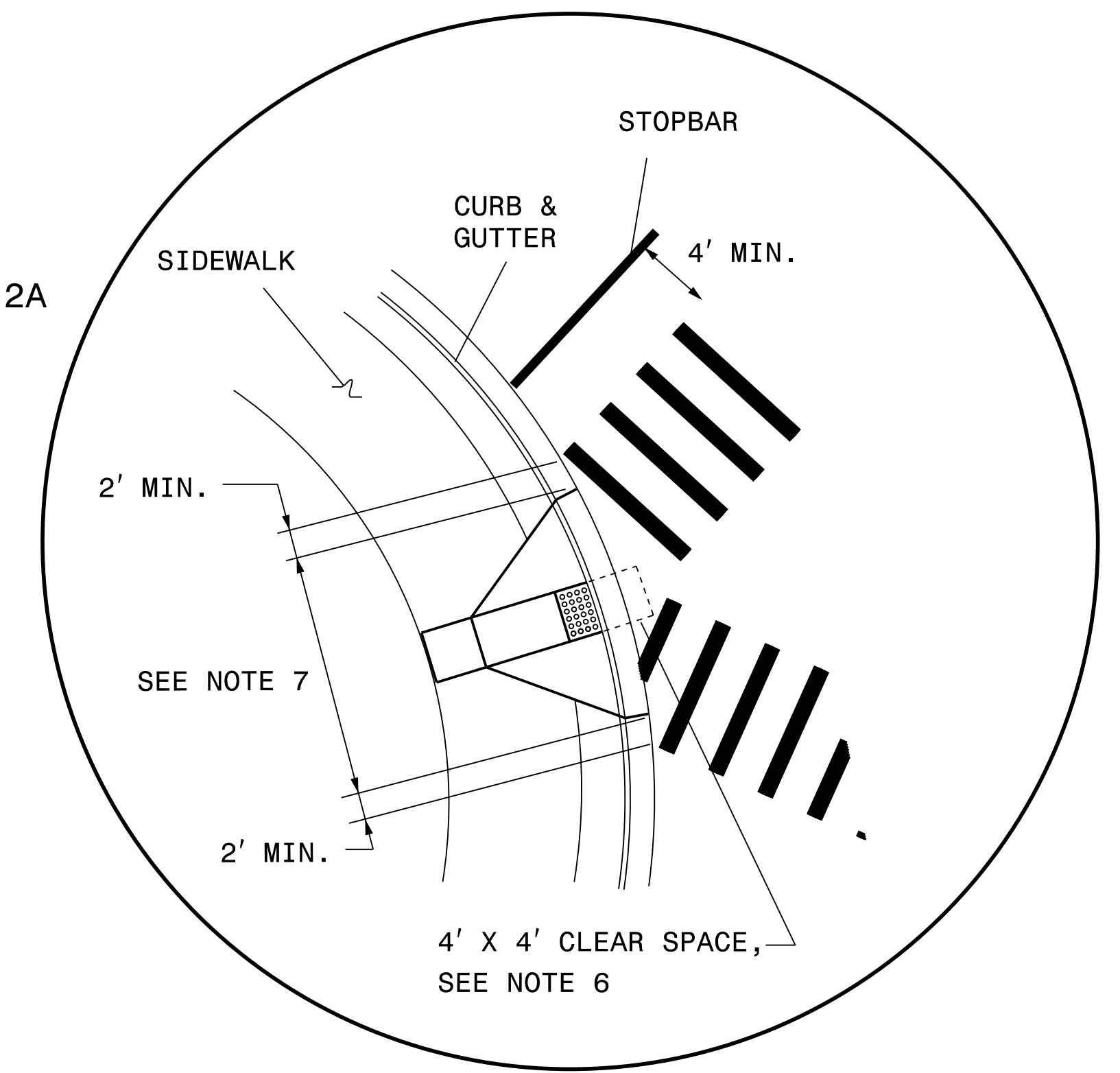

DETAIL 'B'- SINGLE DIAGONAL CURB RAMP

NOTES:

- USE THE DETAILS ABOVE AND THE FOLLOWING NOTES FOR GUIDANCE IN PLACING CROSSWALK MARKINGS. REFER TO NCDOT ROADWAY STANDARD DRAWINGS, MUTCD AND ADA STANDARDS FOR ADDITIONAL GUIDANCE.
- THE LOCATION AND TYPE OF CROSSWALK MARKINGS SHOWN ON THE ABOVE DETAILS ARE FOR REFERENCE ONLY. LOCATE CROSSWALK MARKINGS AS SHOWN ON THE PROJECT DETAIL SHEETS OR AS DIRECTED BY THE ENGINEER. THE CROSSWALK MARKING TYPE, SPECIAL EMPHASIS, SHALL BE INSTALLED AS SPECIFIED ON THE PROJECT DETAIL SHEETS OR AS DIRECTED BY THE ENGINEER.
- THE SPECIAL EMPHASIS CROSSWALK IS WHITE 24" WIDE LONGITUDINAL LINES WITH 60" MAXIMUM GAPS BETWEEN LINES, SEE DETAIL PMP-2A.
- STOP BARS SHOULD BE PLACED A MINIMUM OF 4' IN ADVANCE OF NEAREST CROSSWALK LINE.
- SET BACK DISTANCE FROM INSIDE CROSSWALK MARKING TO NEAREST EDGE OF TRAVEL IS 4' MIN.
- BEYOND THE BOTTOM GRADE BREAK, A CLEAR SPACE OF 4' X 4' MINIMUM SHALL BE PROVIDED WITHIN THE MARKINGS.
- SINGLE DIAGONAL CURB RAMPS WITH FLARED SIDES SHALL HAVE A SEGMENT OF CURB 2 FEET LONG MINIMUM LOCATED ON EACH SIDE OF THE CURB RAMP AND WITHIN THE MARKED CROSSING, SEE DETAIL 'B'.
- CURB RAMPS SHALL BE CONSTRUCTED IN ACCORDANCE TO THE LATEST NCDOT ROADWAY STANDARD DRAWINGS.

9/2/2021
PMP-R5021_PMP_pmp_02-2B.dgn
HNTB

HNTB
HNTB NORTH CAROLINA, P.C.
343 E. SIX FORKS ROAD, SUITE 200
RALEIGH, NORTH CAROLINA 27609
NC License No: C-1554
(919) 546-8997

**CROSSWALK PAVEMENT MARKING
GUIDANCE DETAIL**

TIP NO. R-5021	SHEET NO. PMP-2A
APPROVED: <i>Andrew D. Klinkosiek</i> E3078FB498E44B	
DATE: 9/2/2021	
SEAL	
	
DOCUMENT NOT CONSIDERED FINAL UNLESS ALL SIGNATURES COMPLETED	

STATE OF NORTH CAROLINA
DEPT. OF TRANSPORTATION
DIVISION OF HIGHWAYS
RALEIGH, N.C.

2-19

ENGLISH TYPICAL DRAWING FOR
PAVEMENT MARKINGS
HI-VISIBILITY CROSSWALKS
NO-TRACK MARKING GUIDANCE

SHEET 1 OF 1

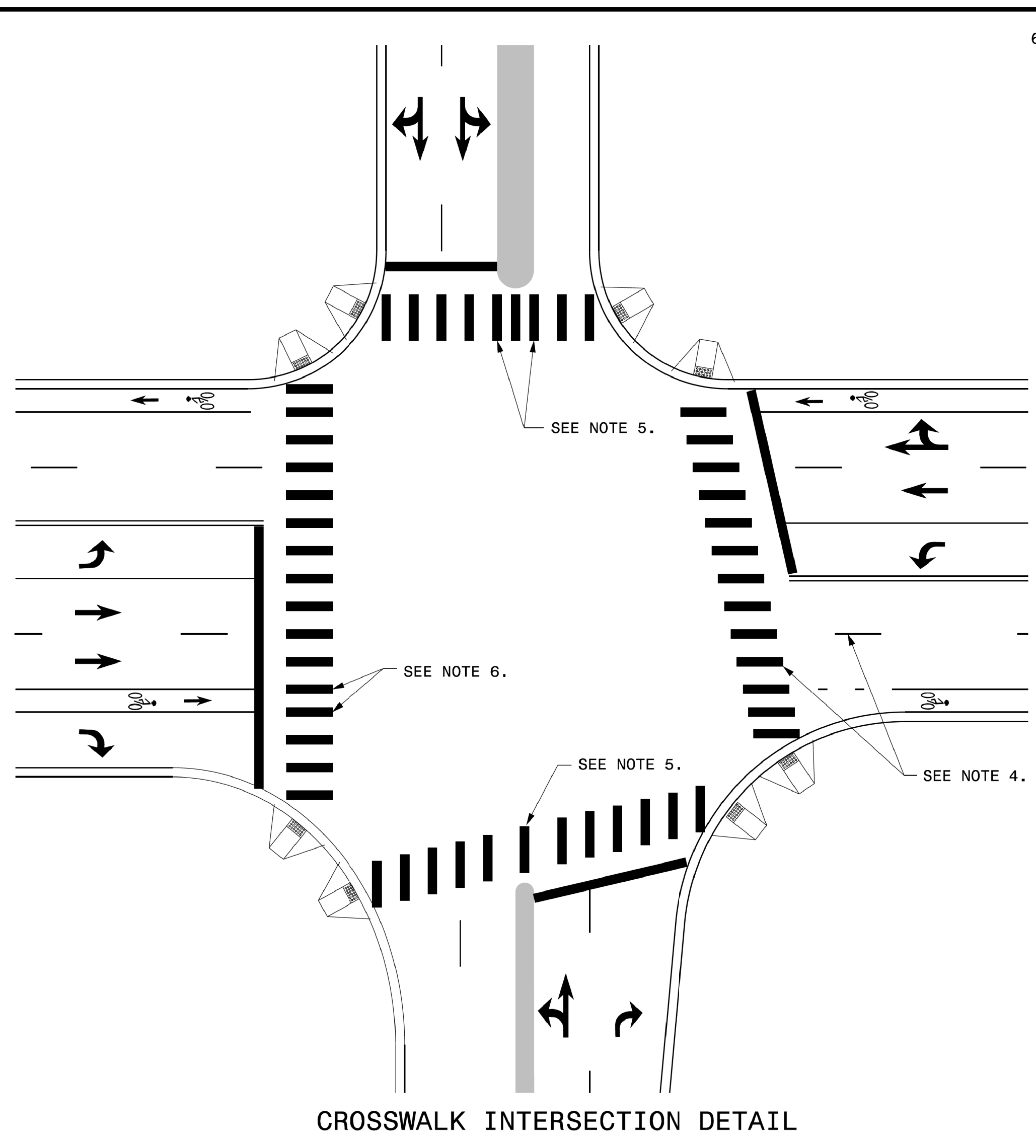

CROSSWALK INTERSECTION DETAIL

- GENERAL NOTES:
- 1- THE GUIDANCE IN THIS DETAIL IS TO BE USED WHEN NO-TRACK SPACING OF HI-VISIBILITY MARKINGS IS REQUESTED.
 - 2- USE THE GUIDANCE SHOWN ON THE ABOVE DETAILS IN CONJUNCTION WITH PAVEMENT MARKING GUIDANCE SHOWN ON ROADWAY STANDARD DRAWINGS 1205.01 AND 1205.07.
 - 3- PLACE MARKINGS TO AVOID WHEELPATH OF VEHICLES. MARKINGS TYPICALLY WILL BE LOCATED CENTERED AT THE LANE LINES AND EDGE LINES WITH ONE ADDITIONAL MARKING CENTERED IN THE MIDDLE OF THE LANE. AT WIDE LANE WIDTHS DUE TO TAPERS AND LARGE RADII, LOCATE MARKINGS AT BEST SPACING TO AVOID WHEEL TRACKING. THE SPACE BETWEEN MARKINGS SHALL NOT BE LESS THAN 24 INCHES OR GREATER THAN 60 INCHES.

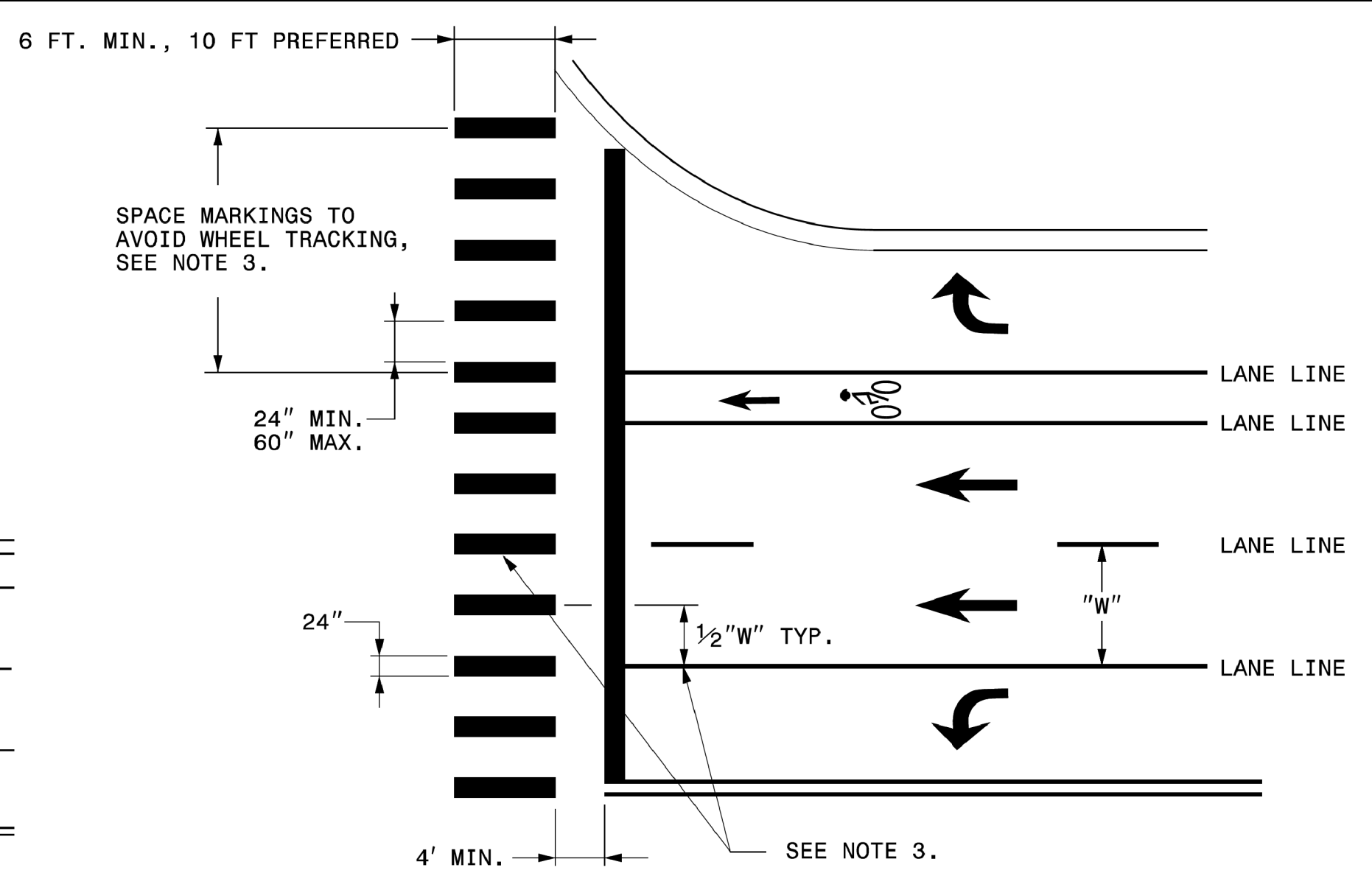

CROSSWALK MARKING DETAIL

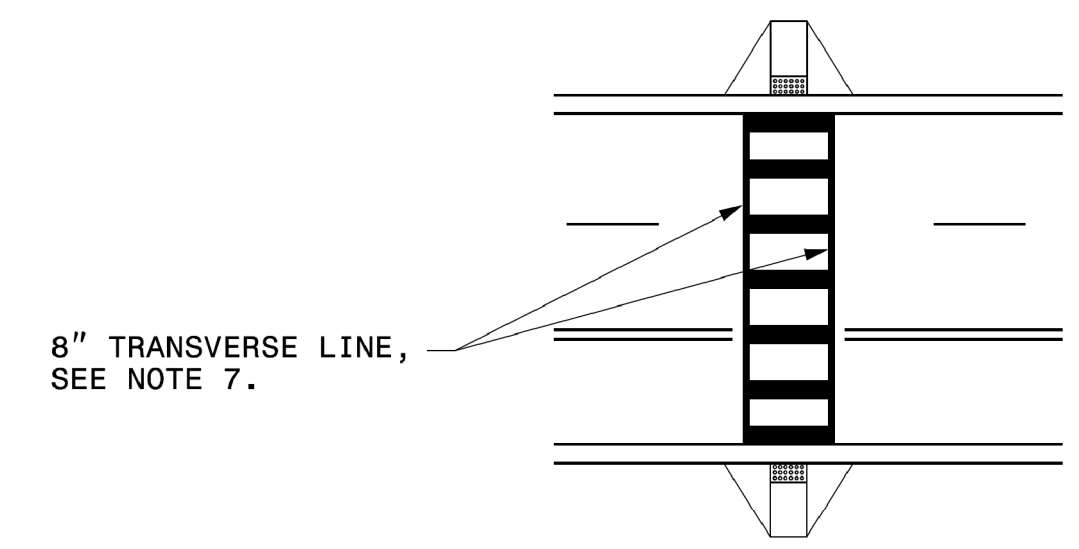

MID-BLOCK CROSSWALK DETAIL

- 4- WHERE THE CROSSWALK IS SKEWED TO THE LANE LINES, THE MARKINGS SHOULD BE PARALLEL TO THE LANE LINES.
- 5- PLACE MARKINGS ON BOTH EDGES OF THE NOSE OF A MEDIAN. FOR NARROW MEDIANS LESS THAN 4 FEET, A SINGLE MARKING MAY BE USED. FOR WIDE MEDIANS, INSTALL ADDITIONAL MARKINGS IN THE MEDIAN AREA. THE SPACE BETWEEN THE MARKINGS SHALL NOT TO BE LESS THAN 24 INCHES OR GREATER THAN 60 INCHES.
- 6- LOCATE MARKINGS CENTERED ON BICYCLE LANE LINES. MARKINGS SHALL NOT BE LOCATED IN THE CENTER OF THE BICYCLE PATH.
- 7- INCLUDE 8" TRANSVERSE LINES WITH 24" LONGITUDINAL MARKINGS AT MID-BLOCK CROSSINGS.

STATE OF NORTH CAROLINA
DEPT. OF TRANSPORTATION
DIVISION OF HIGHWAYS
RALEIGH, N.C.

2-19

ENGLISH TYPICAL DRAWING FOR
PAVEMENT MARKINGS
HI-VISIBILITY CROSSWALKS
NO-TRACK MARKING GUIDANCE

SHEET 1 OF 1

9/2/2021
PMP-R5021_PMP_02-2B.dgn
HNTB

HNTB
HNTB NORTH CAROLINA, P.C.
343 E. SIX FORKS ROAD, SUITE 200
RALEIGH, NORTH CAROLINA 27609
NC LICENSE NO: C-1554
(919) 546-8997

**SPECIAL EMPHASIS HI-VISIBILITY
CROSSWALK MARKING DETAIL**

TIP NO. R-5021	SHEET NO. PMP-4
APPROVED: <i>Andrew D. Klincksiek</i> E3078F84596E44B	
DATE: 10/28/2021	
	
DOCUMENT NOT CONSIDERED FINAL UNLESS ALL SIGNATURES COMPLETED	

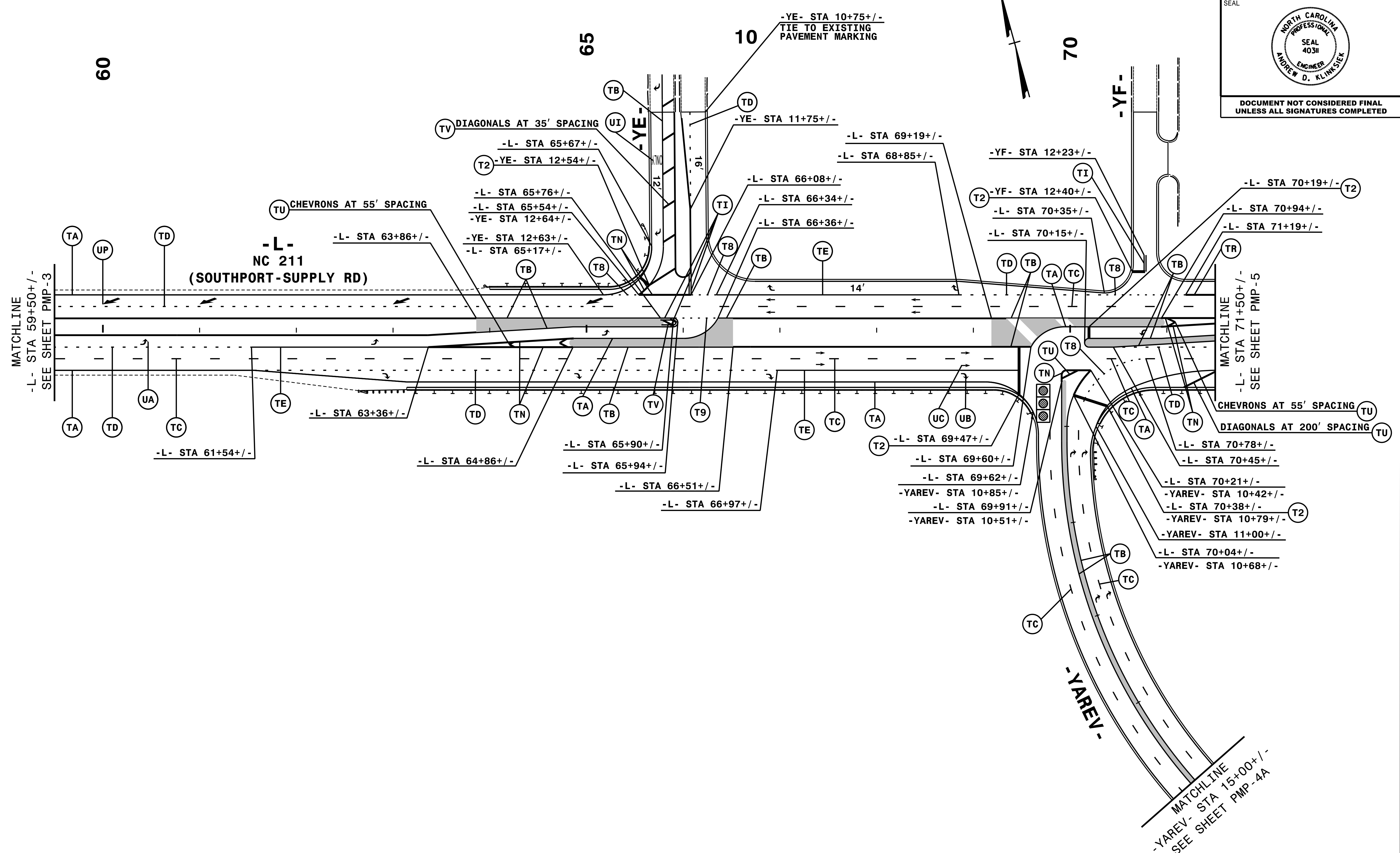

10/28/2021
10:28:00 AM
P:\PMP\5021_PMP_pmp_04.dgn
HNTB

NOTE: ALL LANE WIDTHS ARE 12' UNLESS OTHERWISE SHOWN.

HNTB
 HNTB NORTH CAROLINA, P.C.
 343 E. Six Forks Road, Suite 200
 Raleigh, North Carolina 27609
 NC License No: C-1554
 (919) 546-8997

PAVEMENT MARKING DETAIL

TIP NO. R-5021	SHEET NO. PMP-4A
APPROVED: <i>Andrew D. Klinck</i> E3078F8499E44B	
DATE: 10/28/2021	
	
DOCUMENT NOT CONSIDERED FINAL UNLESS ALL SIGNATURES COMPLETED	

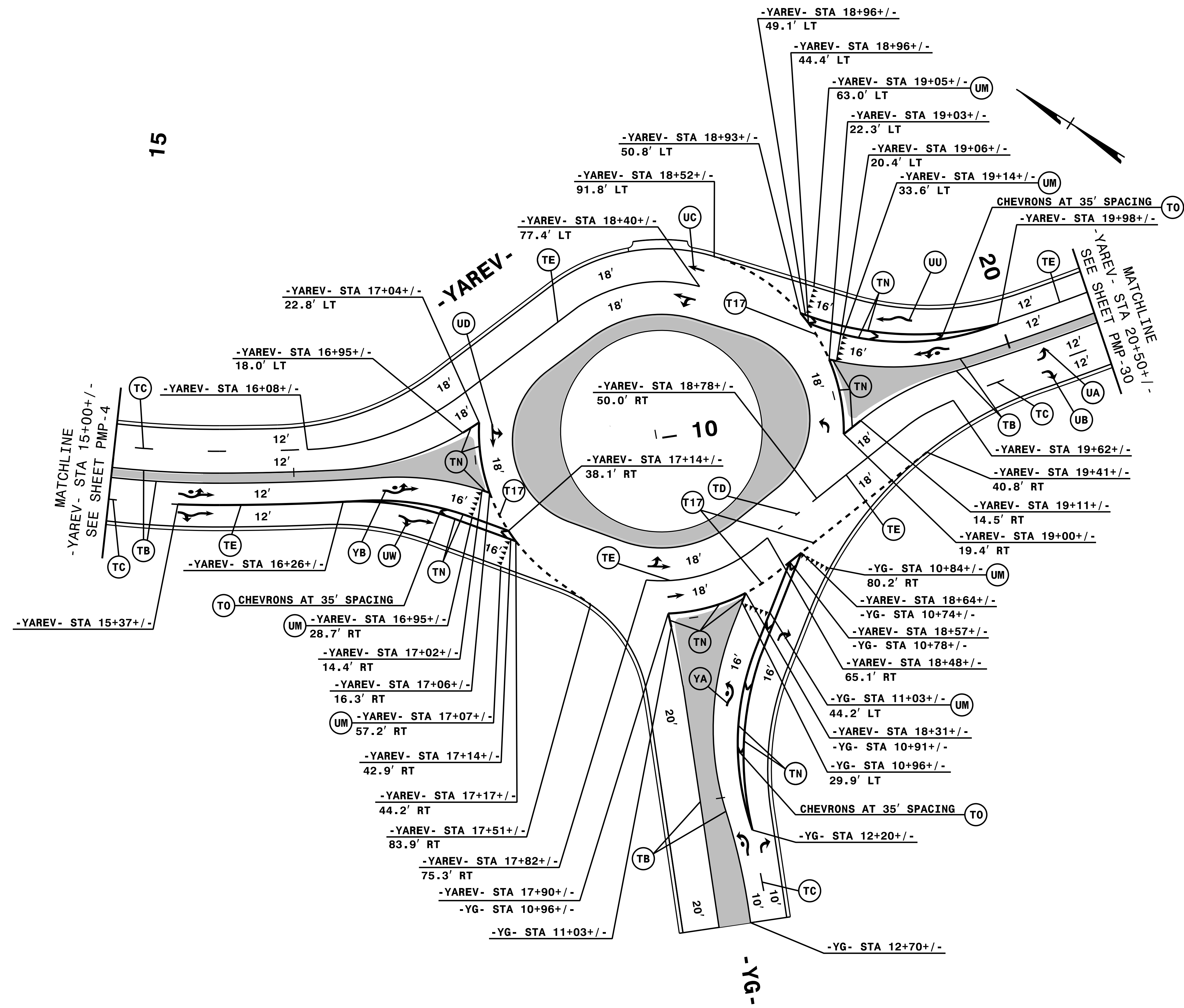

10/28/2021
 I:\PMP\R5021_PMP_pmp_04A.dgn
 HNTB

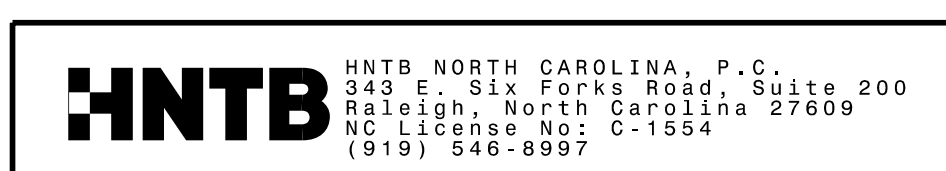

PAVEMENT MARKING DETAIL

TIP NO. R-5021	SHEET NO. PMP-5
APPROVED: <i>Andrew D. Klinck</i> E3078FB4596E48	
DATE: 10/28/2021	
	
DOCUMENT NOT CONSIDERED FINAL UNLESS ALL SIGNATURES COMPLETED	

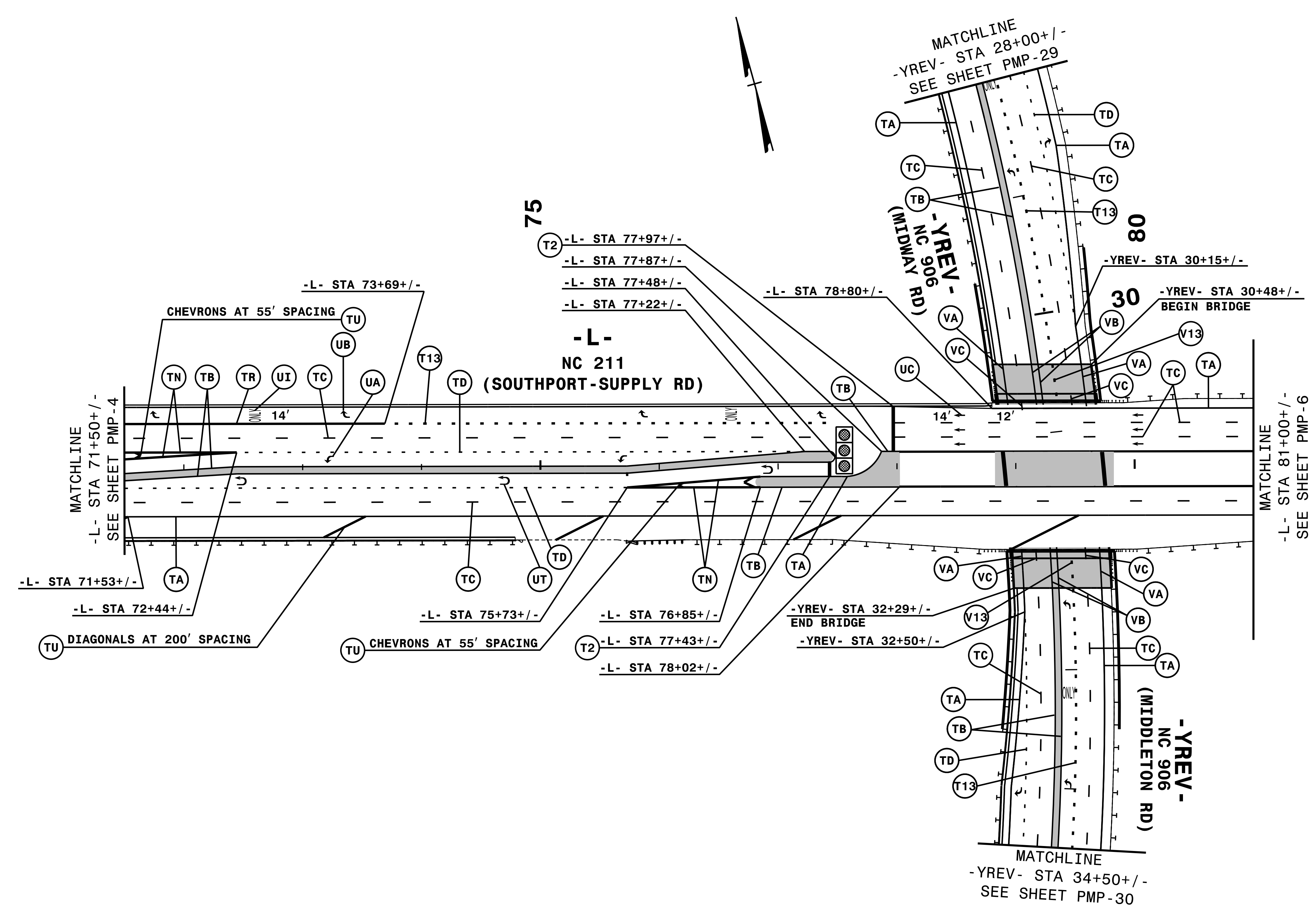

NOTE: ALL LANE WIDTHS ARE 12' UNLESS OTHERWISE SHOWN.

HNTB
 HNTB NORTH CAROLINA, P.C.
 343 E. Six Forks Road, Suite 200
 Raleigh, North Carolina 27609
 NC License No: C-1554
 (919) 546-8997

PAVEMENT MARKING DETAIL

10/28/2021
I:\PMP\R5021_PMP_pmp_05.dgn
HNTB

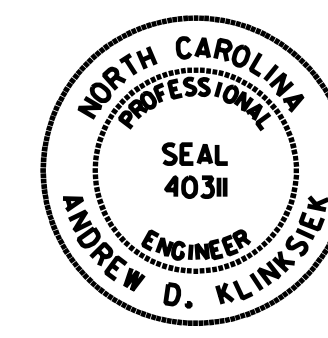
TIP NO. R-5021	SHEET NO. PMP-6
APPROVED: <i>Andrew D. Klincksiek</i> E3078FB4599E44B	
DATE: 10/28/2021	
SEAL	
	
DOCUMENT NOT CONSIDERED FINAL UNLESS ALL SIGNATURES COMPLETED	

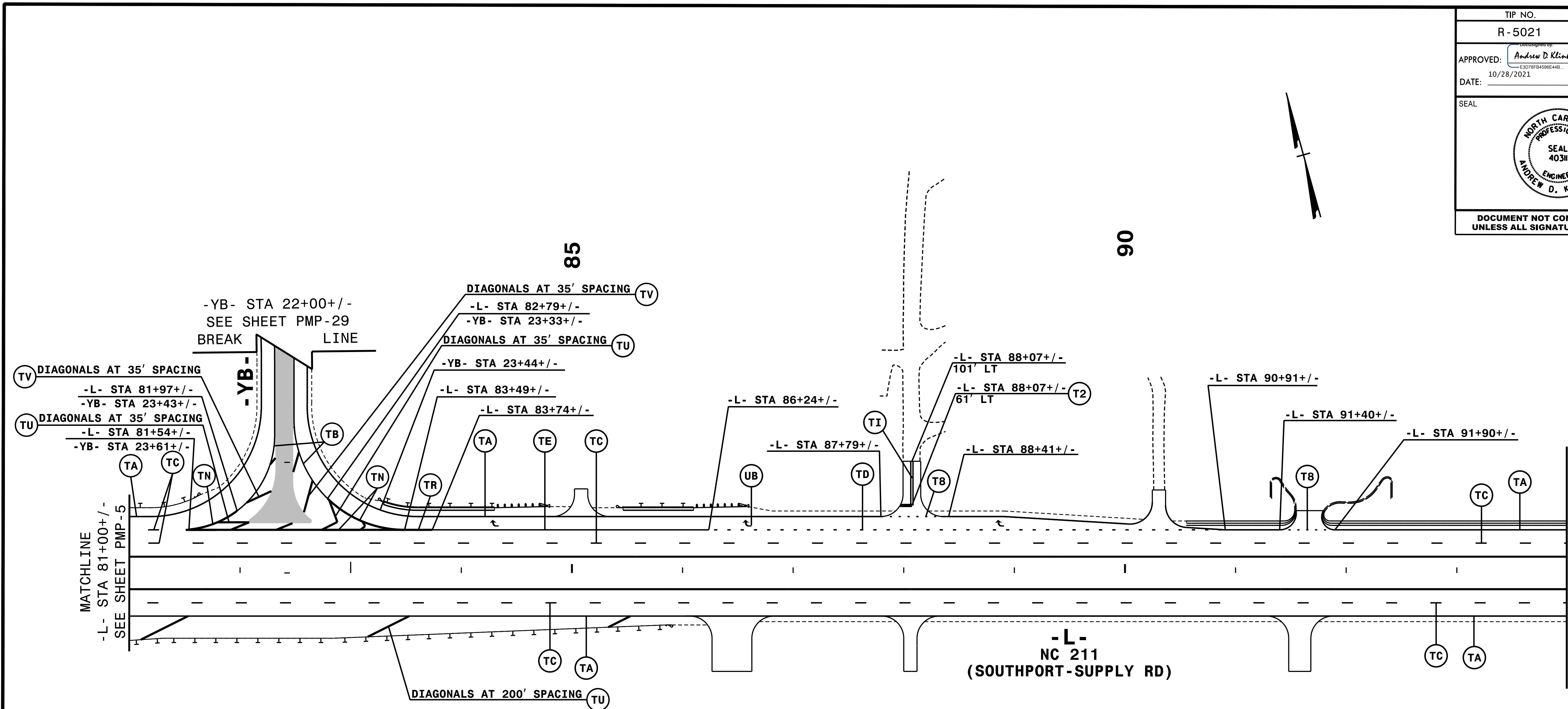

NOTE: ALL LANE WIDTHS ARE 12' UNLESS OTHERWISE SHOWN.

HNTB
 HNTB NORTH CAROLINA, P.C.
 343 E. Six Forks Road, Suite 200
 Raleigh, North Carolina 27609
 NC License No: C-1554
 (919) 546-8997

PAVEMENT MARKING DETAIL

10/28/2021
C:\PMP\15021_PMP_pmp_06.dgn
HNTB

TIP NO. R-5021	SHEET NO. PMP-7
APPROVED: <i>Andrew D. Klincksiek</i> E3078FB4596E44B	
DATE: 10/28/2021	
	
DOCUMENT NOT CONSIDERED FINAL UNLESS ALL SIGNATURES COMPLETED	

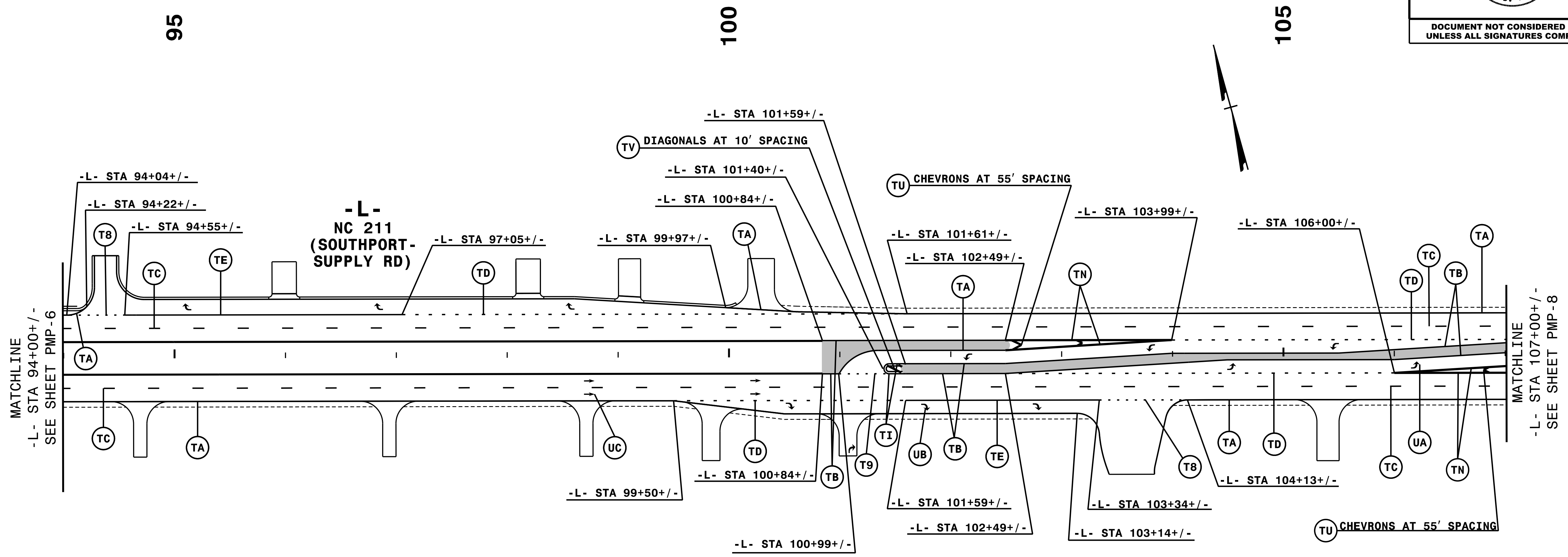

NOTE: ALL LANE WIDTHS ARE 12' UNLESS OTHERWISE SHOWN.

HNTB
 HNTB NORTH CAROLINA, P.C.
 343 E. Six Forks Road, Suite 200
 Raleigh, North Carolina 27609
 NC License No: C-1554
 (919) 546-8997

PAVEMENT MARKING DETAIL

10/28/2021
I:\PMP\R5021_PMP_pmp_07.dgn
HNTB

TIP NO. R-5021 SHEET NO. PMP-5

APPROVED: *Andrew D. Klinkbick*
DocuSigned by: Andrew D. Klinkbick
 E3D78F84598E44B

DATE: 9/2/2021

SEAL



DOCUMENT NOT CONSIDERED FINAL
UNLESS ALL SIGNATURES COMPLETED

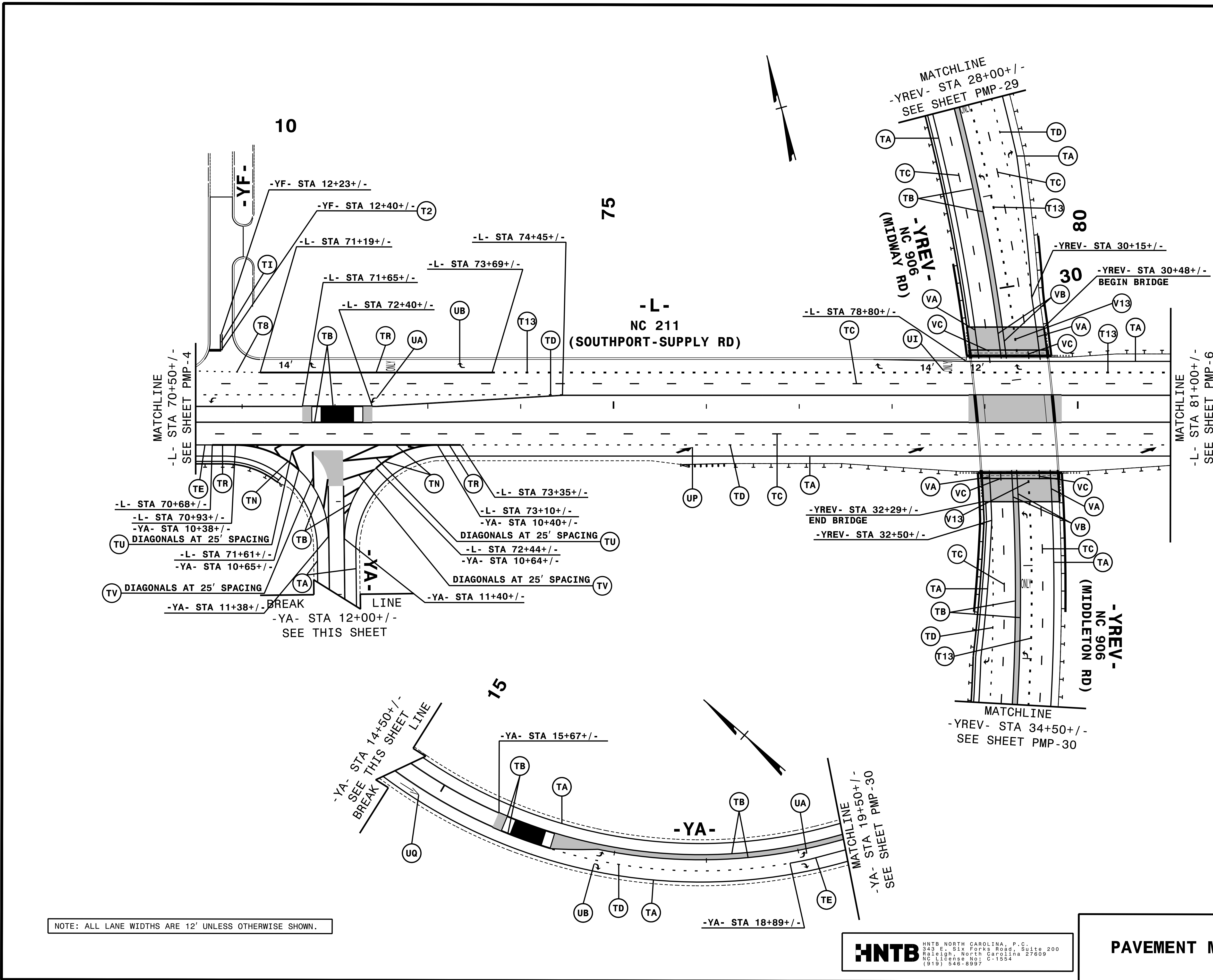

NOTE: ALL LANE WIDTHS ARE 12' UNLESS OTHERWISE SHOWN.

PAVEMENT MARKING DETAIL



HNTB NORTH CAROLINA, P.C.
 343 E. Six Forks Road, Suite 200
 Raleigh, North Carolina 27609
 NC License No: C-1554
 (919) 546-8997

9/2/2021
PMP-5021_PMP_05.dgn
HNTB

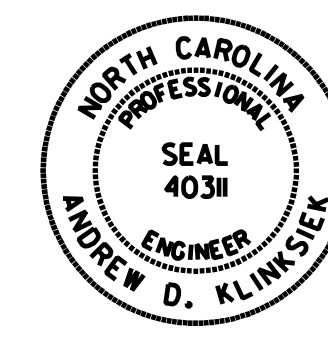
TIP NO. R-5021	SHEET NO. PMP-6
APPROVED: <i>Andrew D. Klincksiek</i> E3078F8459E44B	
DATE: 9/2/2021	
	
DOCUMENT NOT CONSIDERED FINAL UNLESS ALL SIGNATURES COMPLETED	

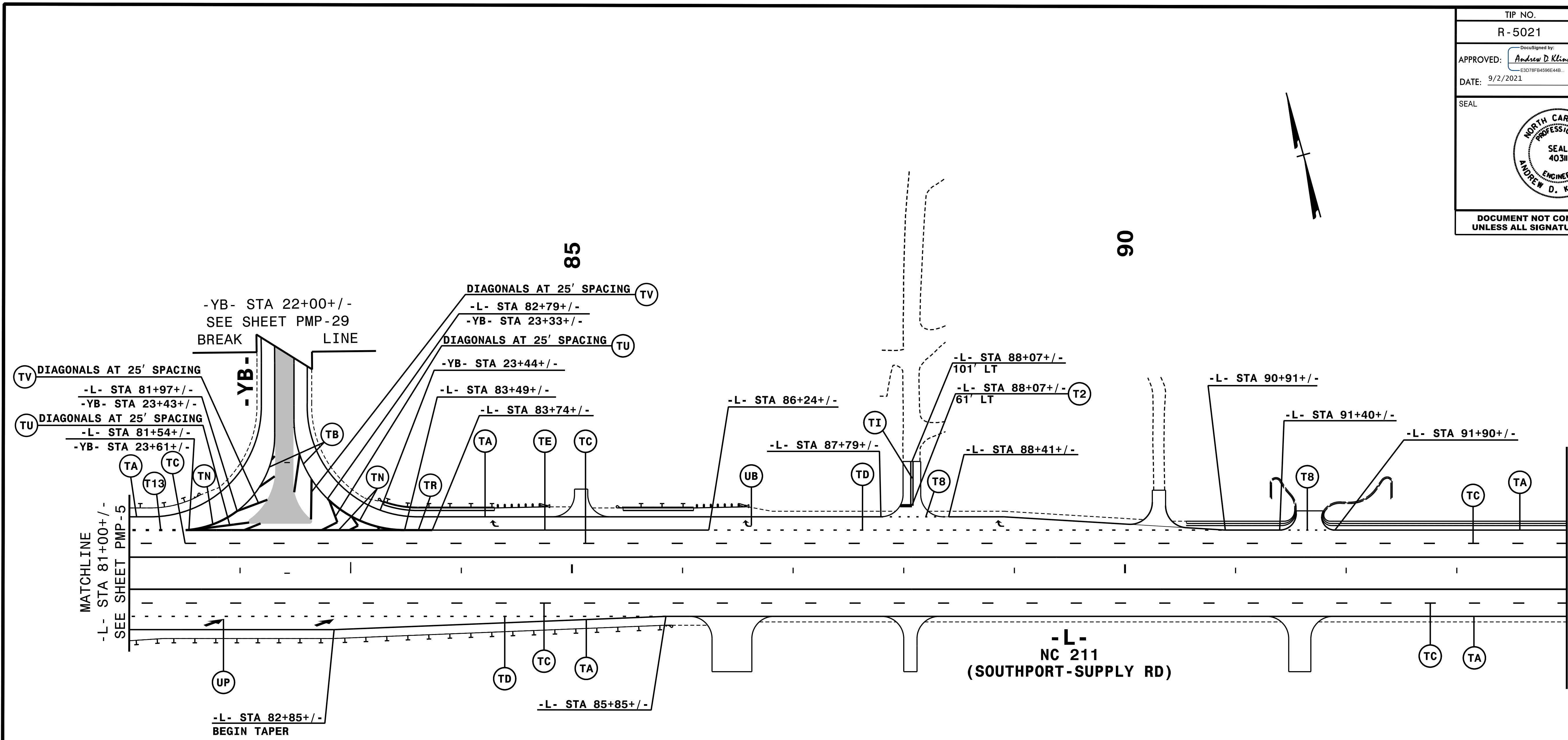

NOTE: ALL LANE WIDTHS ARE 12' UNLESS OTHERWISE SHOWN.

HNTB
 HNTB NORTH CAROLINA, P.C.
 343 E. Six Forks Road, Suite 200
 Raleigh, North Carolina 27609
 NC License No: C-1554
 (919) 546-8997

PAVEMENT MARKING DETAIL

9/2/2021
PMP-5021_PMP-06.dgn
HNTB

TIP NO. R-5021	SHEET NO. PMP-7
APPROVED: <i>Andrew D. Klincksiek</i> <small>E3078FB459E44B</small>	
DATE: 9/2/2021	
	
DOCUMENT NOT CONSIDERED FINAL UNLESS ALL SIGNATURES COMPLETED	

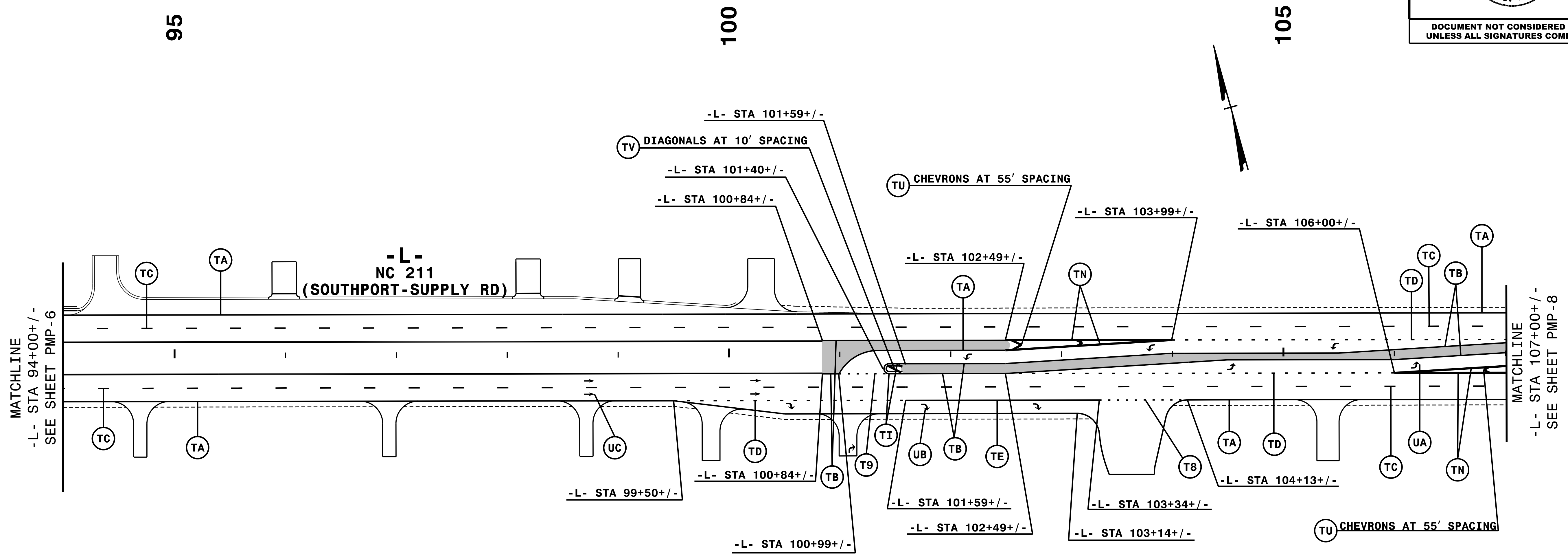

NOTE: ALL LANE WIDTHS ARE 12' UNLESS OTHERWISE SHOWN.

HNTB
 HNTB NORTH CAROLINA, P.C.
 343 E. SIX FORKS ROAD, SUITE 200
 RALEIGH, NORTH CAROLINA 27609
 NC LICENSE NO: C-1554
 (919) 546-8997

PAVEMENT MARKING DETAIL

9/2/2021
PMP-R5021_PMP_07.dgn
HNTB

TIP NO. R-5021	SHEET NO. PMP-8
APPROVED: <i>Andrew D. Klincksiek</i> <small>DocuSigned by: Andrew D. Klincksiek E3D78FB4596E44B</small>	
DATE: 9/2/2021	
SEAL 	
DOCUMENT NOT CONSIDERED FINAL UNLESS ALL SIGNATURES COMPLETED	

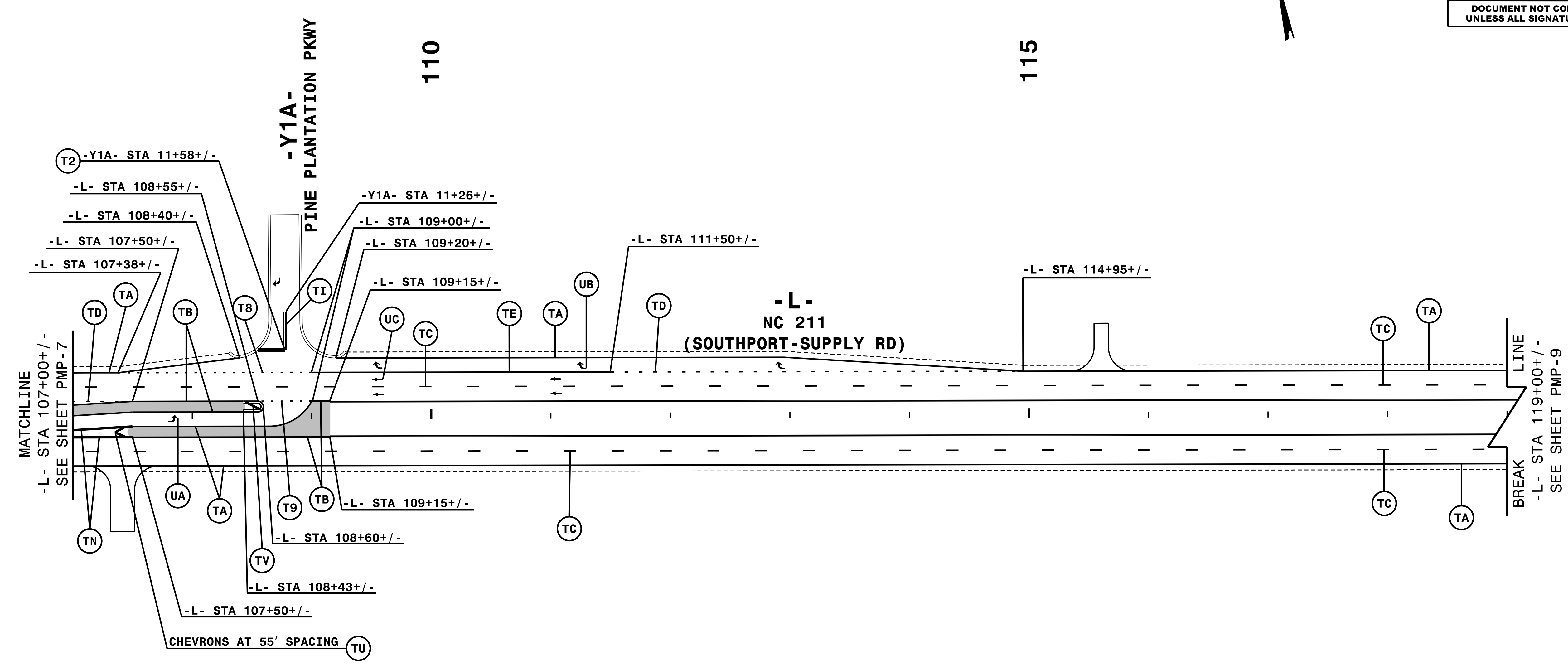

NOTE: ALL LANE WIDTHS ARE 12' UNLESS OTHERWISE SHOWN.

9/2/2021
PMP-R5021_PMP_pmp_08.dgn
HNTB

HNTB
 HNTB NORTH CAROLINA, P.C.
 343 E. Six Forks Road, Suite 200
 Raleigh, North Carolina 27609
 NC License No: C-1554
 (919) 546-8997

PAVEMENT MARKING DETAIL

TIP NO. R-5021	SHEET NO. PMP-9
APPROVED: <i>Andrew D. Klinck</i> E3078FB459E44B	
DATE: 9/2/2021	
	
DOCUMENT NOT CONSIDERED FINAL UNLESS ALL SIGNATURES COMPLETED	

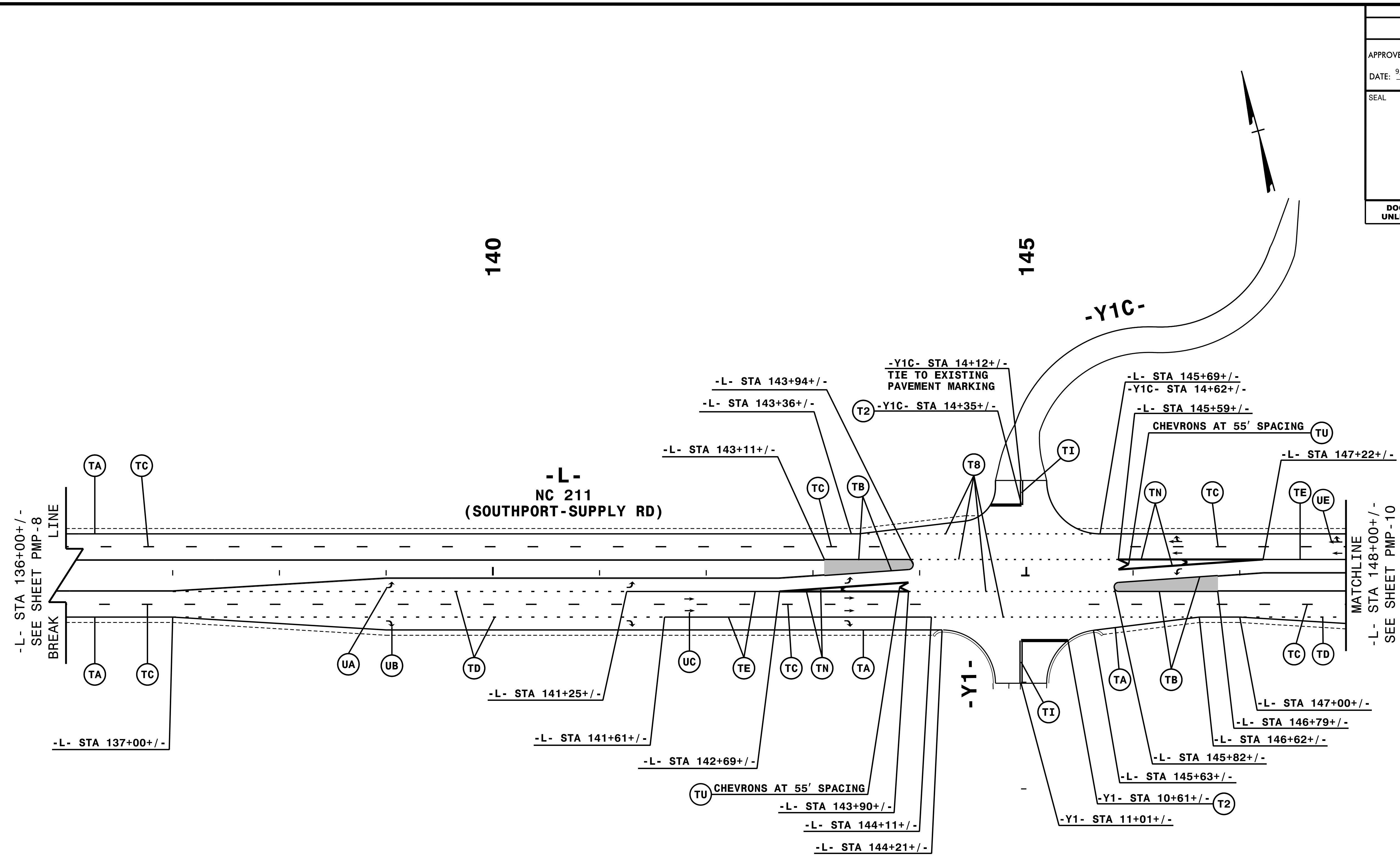

NOTE: ALL LANE WIDTHS ARE 12' UNLESS OTHERWISE SHOWN.

9/2/2021
PMP-R5021_PMP_09.dgn
HNTB

HNTB
 HNTB NORTH CAROLINA, P.C.
 343 E. SIX FORKS ROAD, SUITE 200
 RALEIGH, NORTH CAROLINA 27609
 NC LICENSE NO: C-1554
 (919) 546-8997

PAVEMENT MARKING DETAIL

TIP NO. R-5021	SHEET NO. PMP-10
APPROVED: <i>Andrew D. Klincksiek</i> E3078FB4596E44B	
DATE: 9/2/2021	
	
DOCUMENT NOT CONSIDERED FINAL UNLESS ALL SIGNATURES COMPLETED	

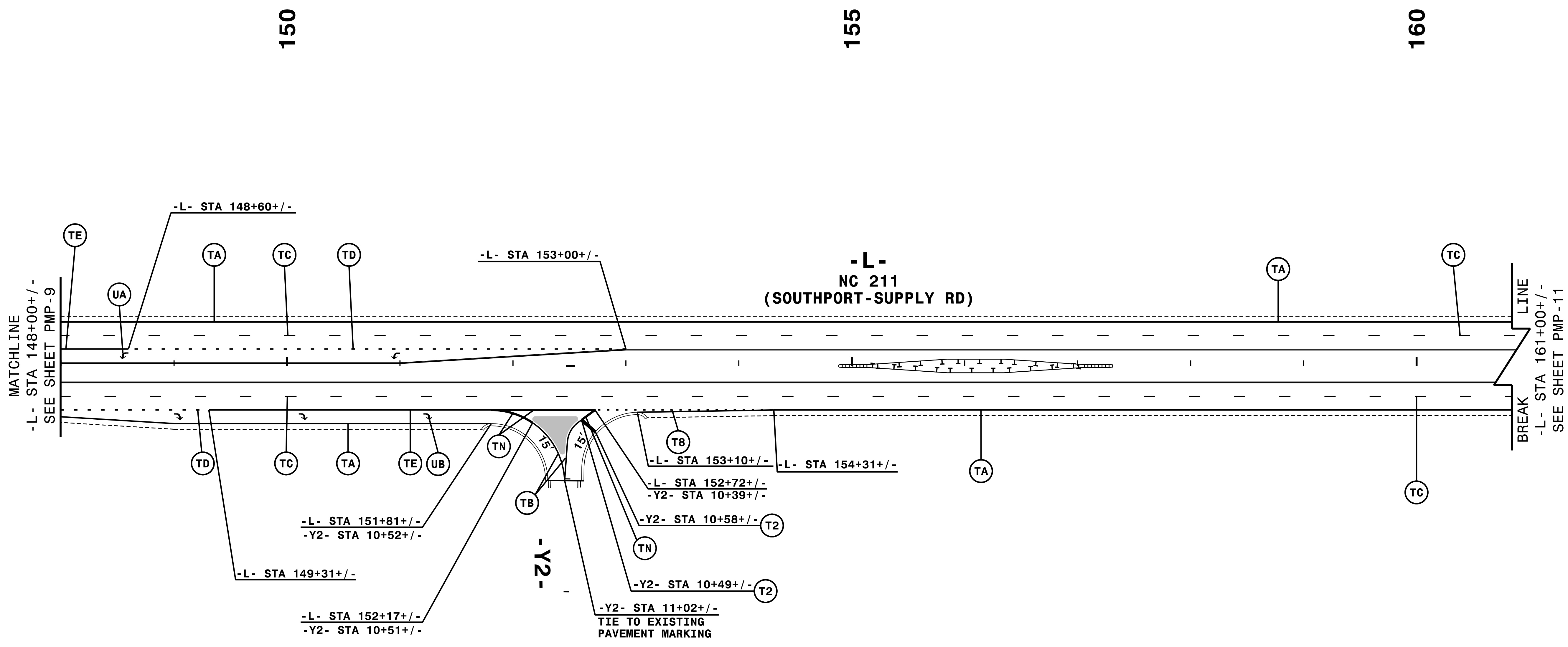

NOTE: ALL LANE WIDTHS ARE 12' UNLESS OTHERWISE SHOWN.

9/2/2021
PMP-R5021_PMP_pmp_10.dgn
HNTB

HNTB

HNTB NORTH CAROLINA, P.C.
343 E. SIX FORKS ROAD, SUITE 200
RALEIGH, NORTH CAROLINA 27609
NC LICENSE NO: C-1554
(919) 546-8997

PAVEMENT MARKING DETAIL

TIP NO. R-5021	SHEET NO. PMP-11
APPROVED: <i>Andrew D. Klimesiek</i> E-3078FB4596E44B	
DATE: 9/2/2021	
SEAL 	
DOCUMENT NOT CONSIDERED FINAL UNLESS ALL SIGNATURES COMPLETED	

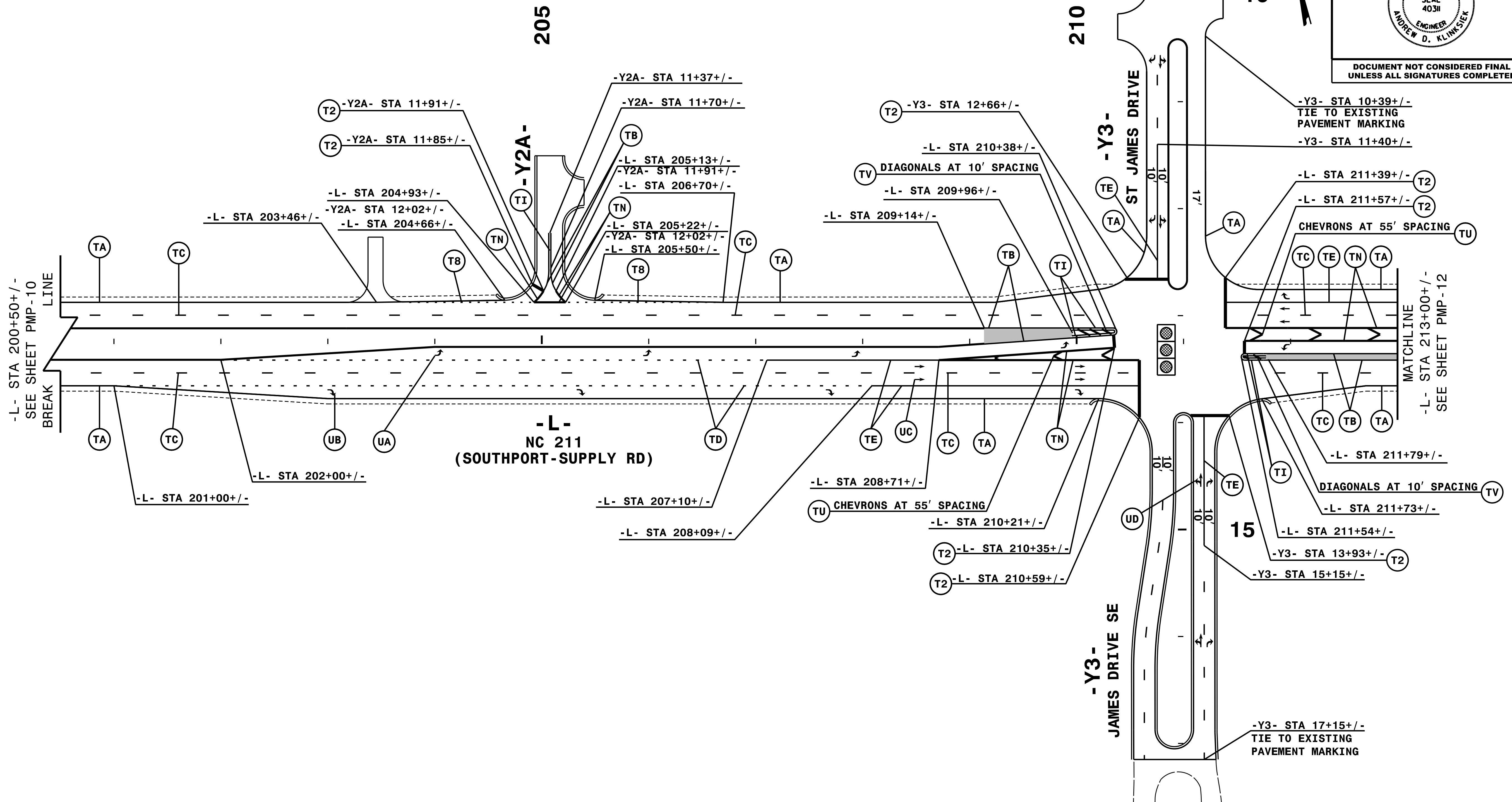

NOTE: ALL LANE WIDTHS ARE 12' UNLESS OTHERWISE SHOWN.

HNTB
 HNTB NORTH CAROLINA, P.C.
 343 E. Six Forks Road, Suite 200
 Raleigh, North Carolina 27609
 NC License No: C-1554
 (919) 546-8997

PAVEMENT MARKING DETAIL

9/2/2021
PMP-R5021_PMP_pmp_11.dgn
HNTB

TIP NO. R-5021	SHEET NO. PMP-12
APPROVED: <i>Andrew D. Klincksiek</i> <small>DocuSigned by: Andrew D. Klincksiek E3D78FB4596E44B...</small>	
DATE: 9/2/2021	
SEAL 	
DOCUMENT NOT CONSIDERED FINAL UNLESS ALL SIGNATURES COMPLETED	

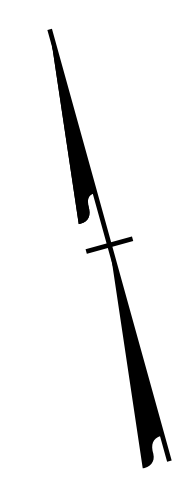
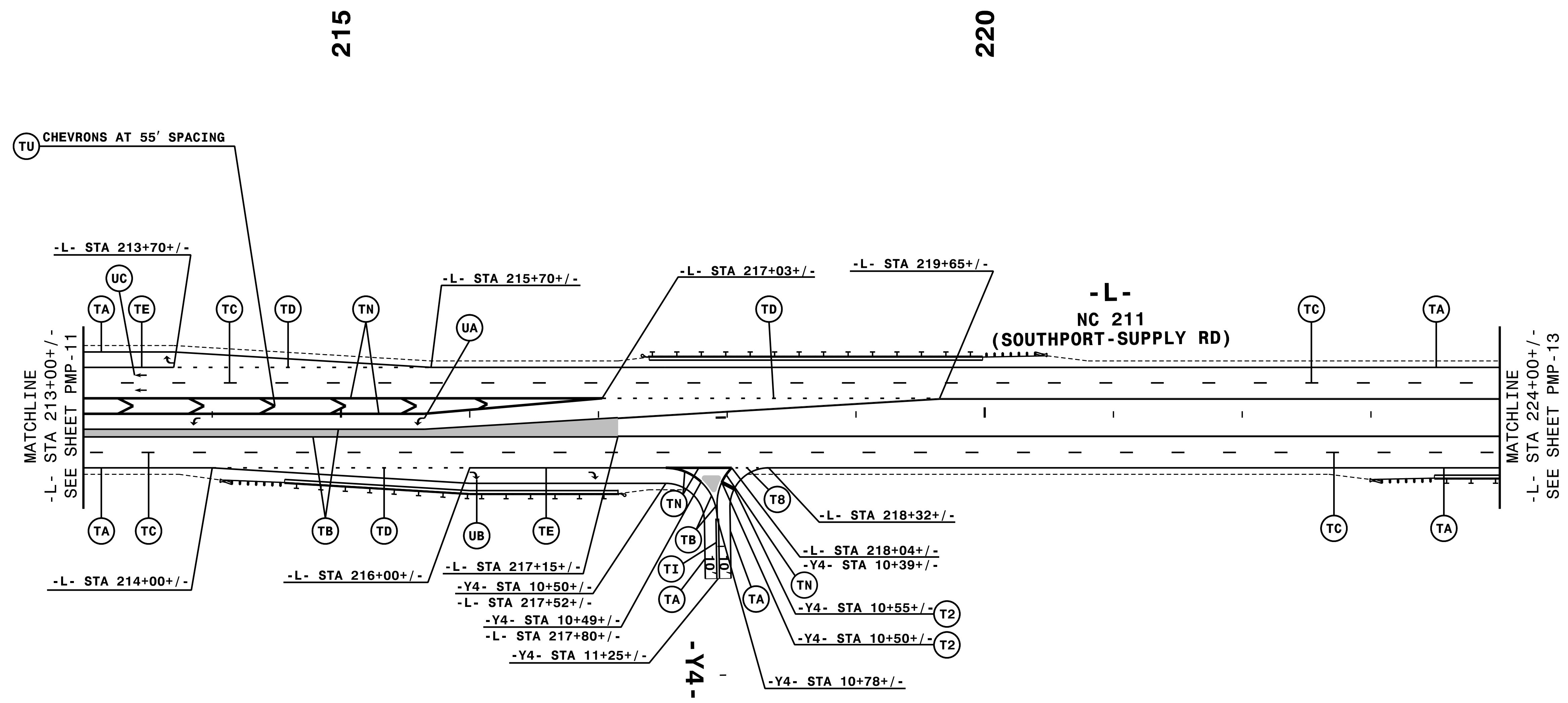

NOTE: ALL LANE WIDTHS ARE 12' UNLESS OTHERWISE SHOWN.

HNTB
 HNTB NORTH CAROLINA, P.C.
 343 E. Six Forks Road, Suite 200
 Raleigh, North Carolina 27609
 NC License No: C-1554
 (919) 546-8997

PAVEMENT MARKING DETAIL

9/2/2021
 P:\PMP\R5021_PMP_pmp_12.dgn
 HNTB

TIP NO. R-5021	SHEET NO. PMP-13
APPROVED: <i>Andrew D. Klincksiek</i> E3078FB4596E44B	
DATE: 9/2/2021	
	
DOCUMENT NOT CONSIDERED FINAL UNLESS ALL SIGNATURES COMPLETED	

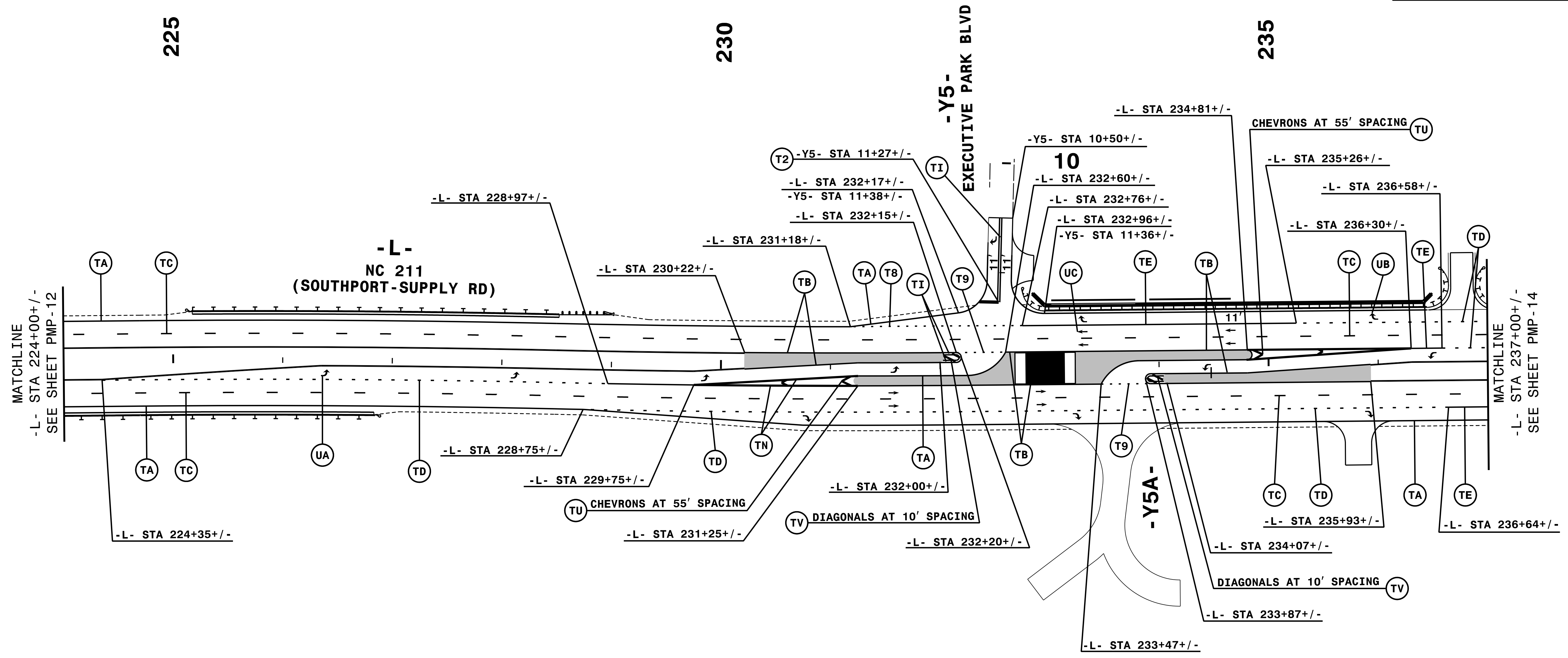

NOTE: ALL LANE WIDTHS ARE 12' UNLESS OTHERWISE SHOWN.

HNTB
 HNTB NORTH CAROLINA, P.C.
 343 E. Six Forks Road, Suite 200
 Raleigh, North Carolina 27609
 NC License No: C-1554
 (919) 546-8997

PAVEMENT MARKING DETAIL

9/2/2021
PMP-R5021_PMP_13.dgn
HNTB

TIP NO. R-5021	SHEET NO. PMP-14
APPROVED: <i>Andrew D. Klincksiek</i> <small>ES078FB4596E44B</small>	
DATE: 9/2/2021	
	
DOCUMENT NOT CONSIDERED FINAL UNLESS ALL SIGNATURES COMPLETED	

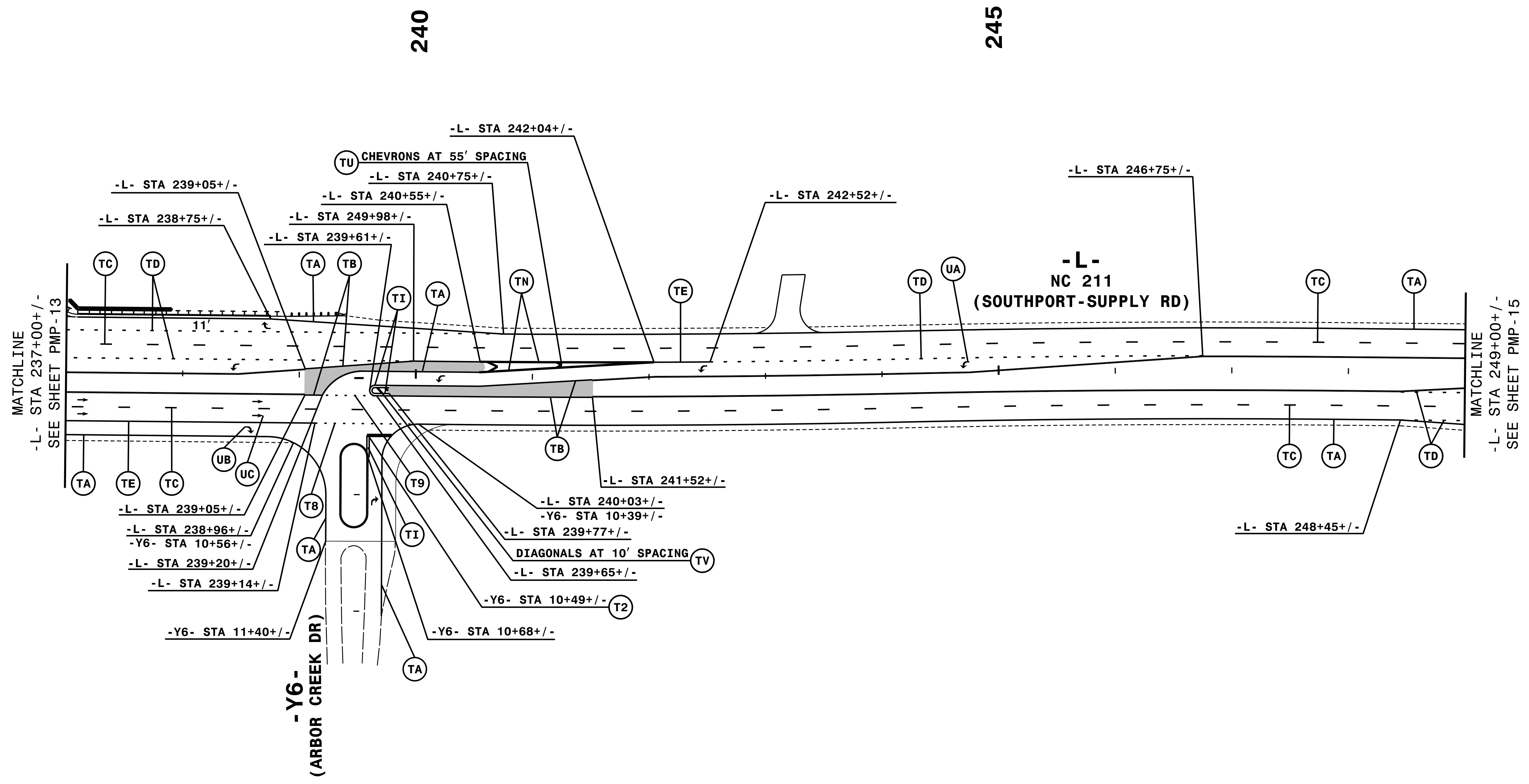
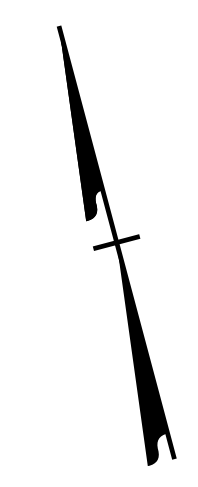

NOTE: ALL LANE WIDTHS ARE 12' UNLESS OTHERWISE SHOWN.

9/2/2021
PMP-R5021_PMP_14.dgn
HNTB

HNTB HNTB NORTH CAROLINA, P.C.
343 E. SIX FORKS ROAD, SUITE 200
RALEIGH, NORTH CAROLINA 27609
NC LICENSE NO: C-1554
(919) 546-8997

PAVEMENT MARKING DETAIL

TIP NO. R-5021	SHEET NO. PMP-15
APPROVED: <i>Andrew D. Klincksiek</i> E3078FB4596E44B	
DATE: 9/2/2021	
	
DOCUMENT NOT CONSIDERED FINAL UNLESS ALL SIGNATURES COMPLETED	

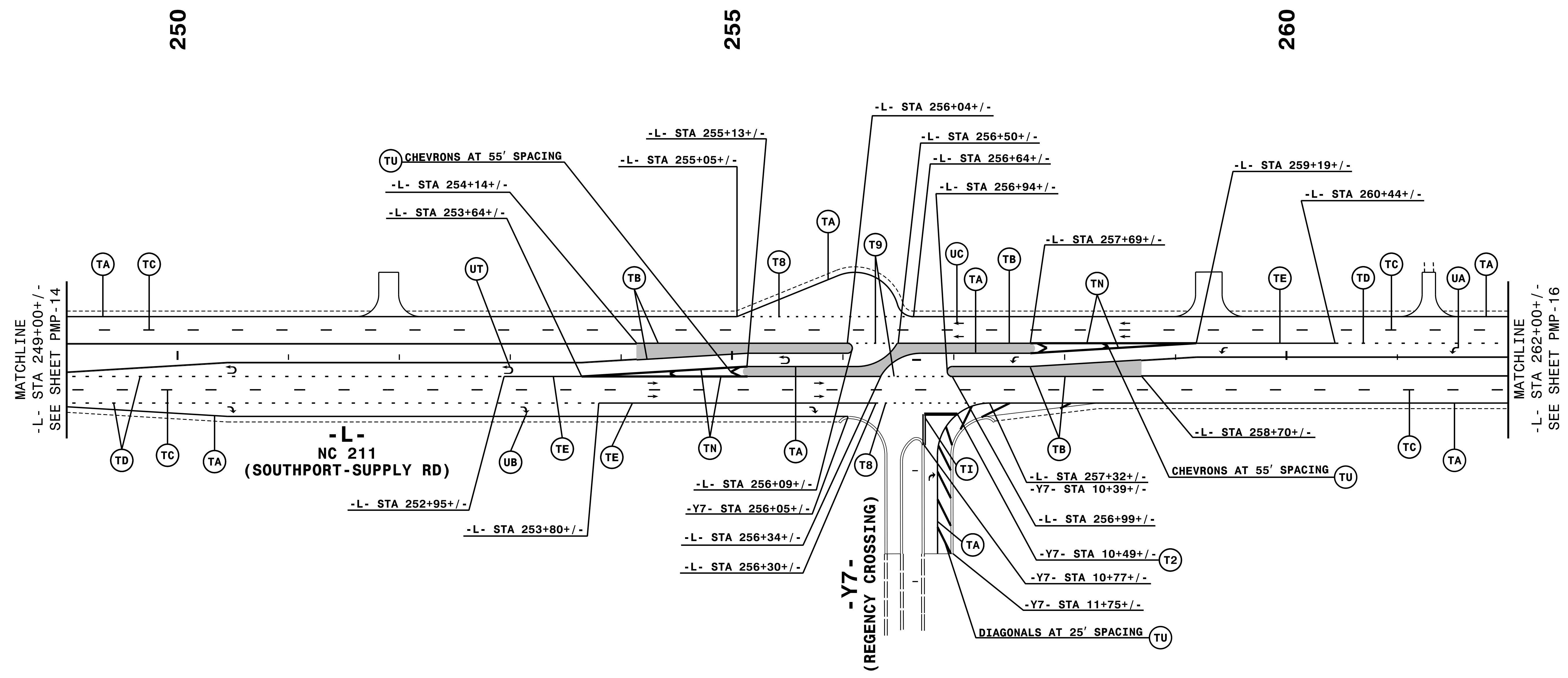
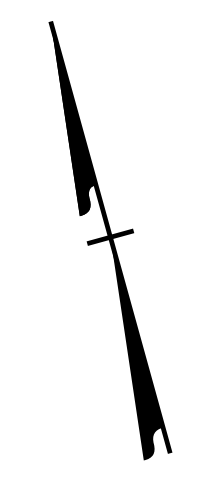

NOTE: ALL LANE WIDTHS ARE 12' UNLESS OTHERWISE SHOWN.

HNTB
 HNTB NORTH CAROLINA, P.C.
 343 E. SIX FORKS ROAD, SUITE 200
 RALEIGH, NORTH CAROLINA 27609
 NC LICENSE NO: C-1554
 (919) 546-8997

PAVEMENT MARKING DETAIL

9/2/2021
PMP-R5021_PMP_15.dgn
HNTB

TIP NO. R-5021	SHEET NO. PMP-19
APPROVED: <i>Andrew D. Klincksiek</i> E3078FB4596E44B	
DATE: 10/28/2021	
	
DOCUMENT NOT CONSIDERED FINAL UNLESS ALL SIGNATURES COMPLETED	

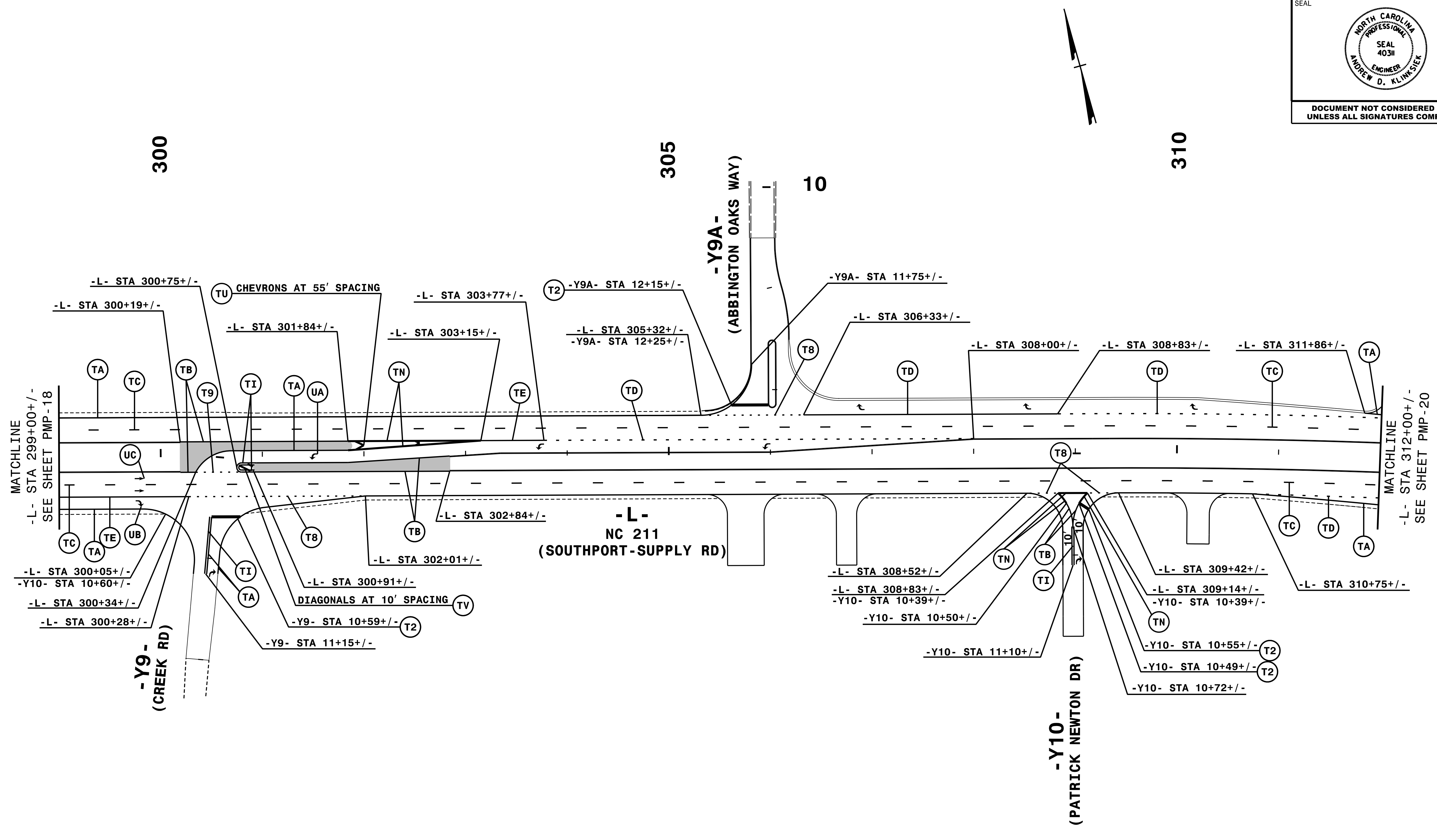

NOTE: ALL LANE WIDTHS ARE 12' UNLESS OTHERWISE SHOWN.

10/28/2021 10:28:19 AM P:\PMP\R5021_PMP_pmp_19.dgn HNTB

HNTB
 HNTB NORTH CAROLINA, P.C.
 343 E. Six Forks Road, Suite 200
 Raleigh, North Carolina 27609
 NC License No: C-1554
 (919) 546-8997

PAVEMENT MARKING DETAIL

TIP NO. R-5021	SHEET NO. PMP-20
APPROVED: <i>Andrew D. Klincksiek</i> E3078FB4596E44B	
DATE: 10/28/2021	
	
DOCUMENT NOT CONSIDERED FINAL UNLESS ALL SIGNATURES COMPLETED	

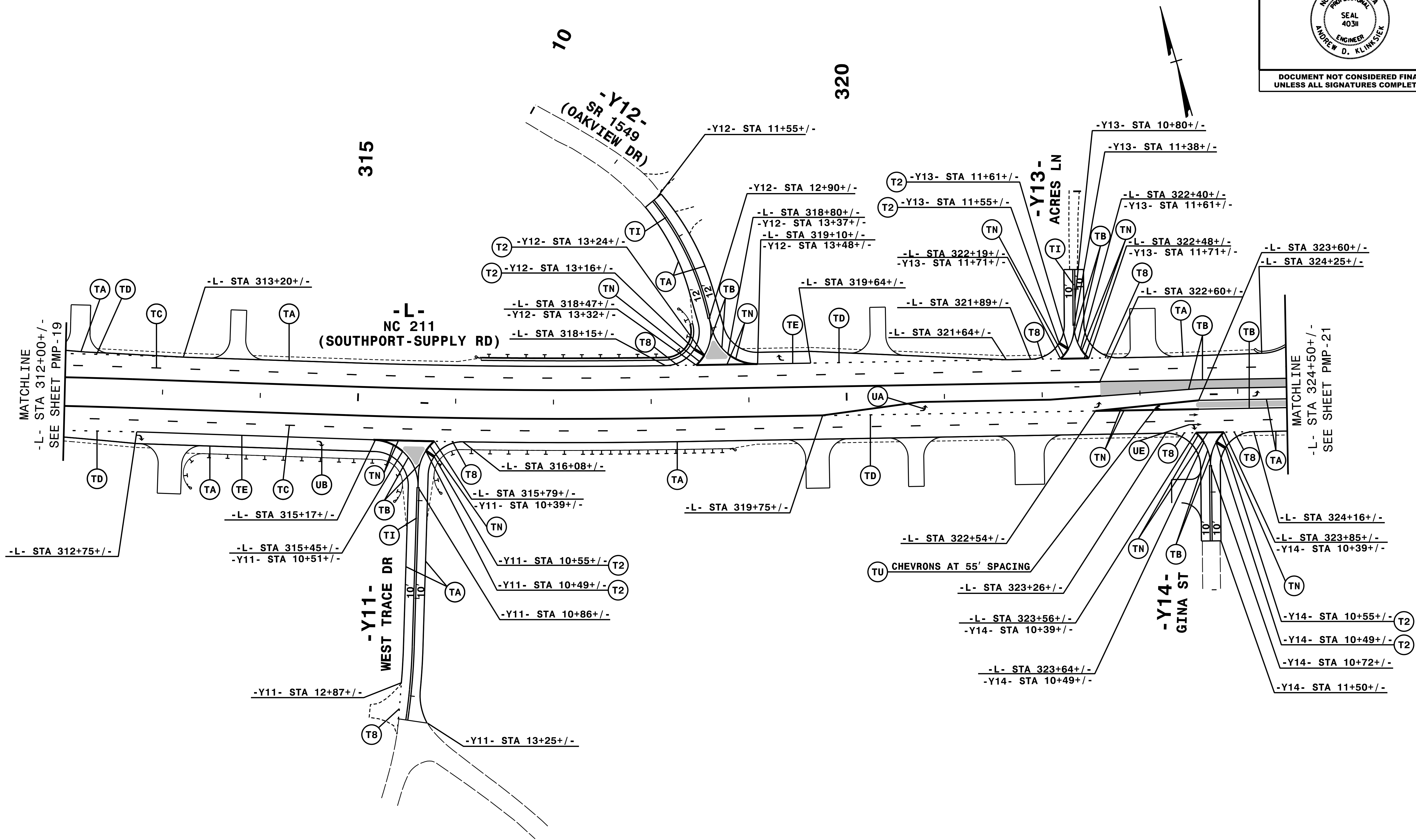

NOTE: ALL LANE WIDTHS ARE 12' UNLESS OTHERWISE SHOWN.

HNTB
 HNTB NORTH CAROLINA, P.C.
 343 E. Six Forks Road, Suite 200
 Raleigh, North Carolina 27609
 NC License No: C-1554
 (919) 546-8997

PAVEMENT MARKING DETAIL

10/28/2021
I:\PMP\R5021_PMP_pmp_20.dgn
HNTB

TIP NO. R-5021	SHEET NO. PMP-18
APPROVED: <i>Andrew D. Klinck</i> <small>DocuSigned by: E3D78FB4596E44B</small>	
DATE: 9/2/2021	
	
DOCUMENT NOT CONSIDERED FINAL UNLESS ALL SIGNATURES COMPLETED	

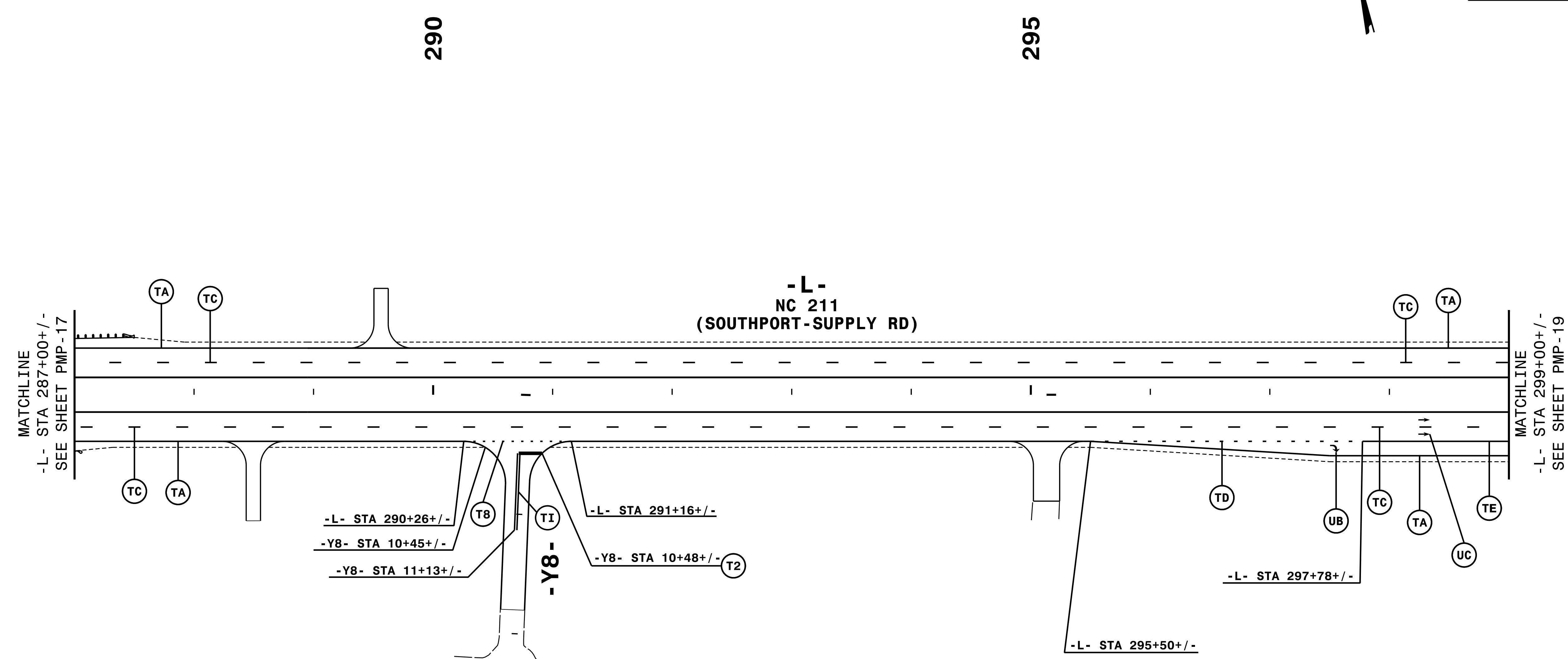

NOTE: ALL LANE WIDTHS ARE 12' UNLESS OTHERWISE SHOWN.

HNTB

HNTB NORTH CAROLINA, P.C.
343 E. SIX FORKS ROAD, SUITE 200
RALEIGH, NORTH CAROLINA 27609
NC LICENSE NO: C-1554
(919) 546-8997

PAVEMENT MARKING DETAIL

9/2/2021
PMP-R5021_L_PMP_18.dgn
HNTB

TIP NO. R-5021	SHEET NO. PMP-19
APPROVED: <i>Andrew D. Klincksiek</i> <small>DocuSigned by: E3D78FB4596E44B</small>	
DATE: 9/2/2021	
SEAL 	
DOCUMENT NOT CONSIDERED FINAL UNLESS ALL SIGNATURES COMPLETED	

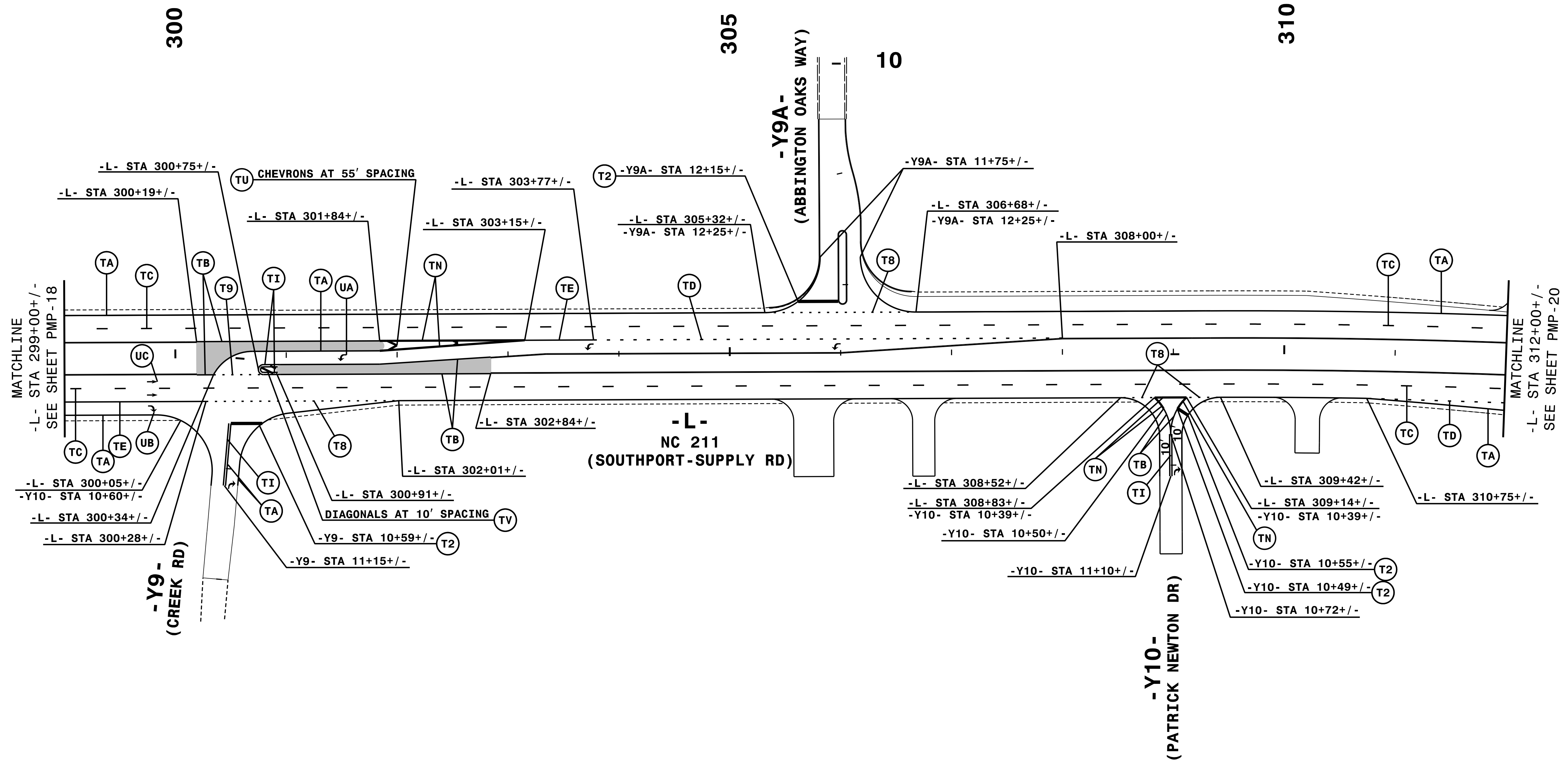

NOTE: ALL LANE WIDTHS ARE 12' UNLESS OTHERWISE SHOWN.

HNTB
 HNTB NORTH CAROLINA, P.C.
 343 E. Six Forks Road, Suite 200
 Raleigh, North Carolina 27609
 NC License No: C-1554
 (919) 546-8997

PAVEMENT MARKING DETAIL

9/2/2021
PMP-R5021_PMP_pmp_19.dgn
HNTB

TIP NO. R-5021	SHEET NO. PMP-20
APPROVED: <i>Andrew D. Klincksiek</i> E3078FB459E44B	
DATE: 9/2/2021	
SEAL 	
DOCUMENT NOT CONSIDERED FINAL UNLESS ALL SIGNATURES COMPLETED	

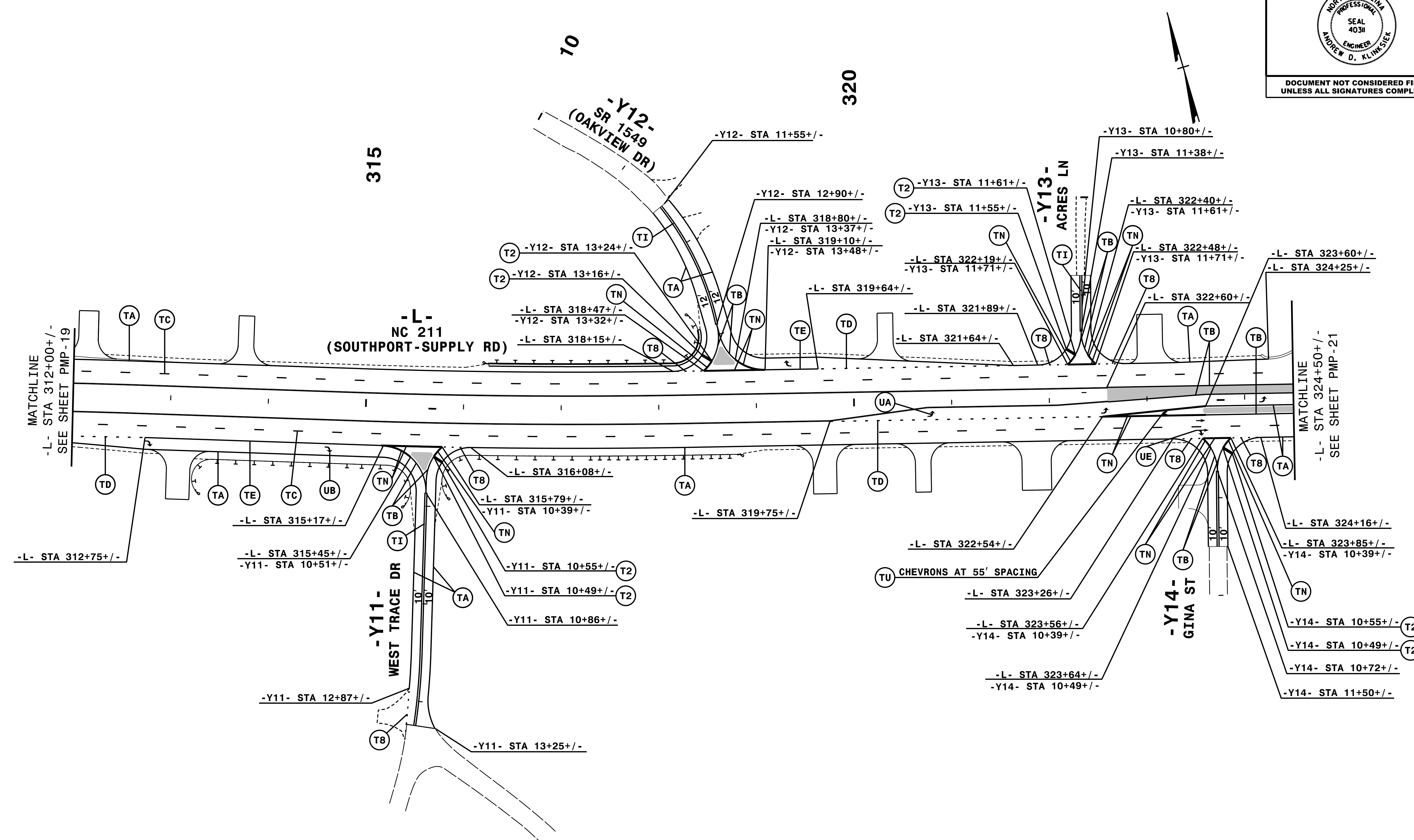

NOTE: ALL LANE WIDTHS ARE 12' UNLESS OTHERWISE SHOWN.

HNTB
 HNTB NORTH CAROLINA, P.C.
 343 E. Six Forks Road, Suite 200
 Raleigh, North Carolina 27609
 NC License No: C-1554
 (919) 546-8997

PAVEMENT MARKING DETAIL

9/2/2021
PMP-R5021_PMP_pmp_20.dgn
HNTB

TIP NO. R-5021	SHEET NO. PMP-21
APPROVED: <i>Andrew D. Klincksiek</i> E-3078FB459E44B	
DATE: 9/2/2021	
SEAL 	
DOCUMENT NOT CONSIDERED FINAL UNLESS ALL SIGNATURES COMPLETED	

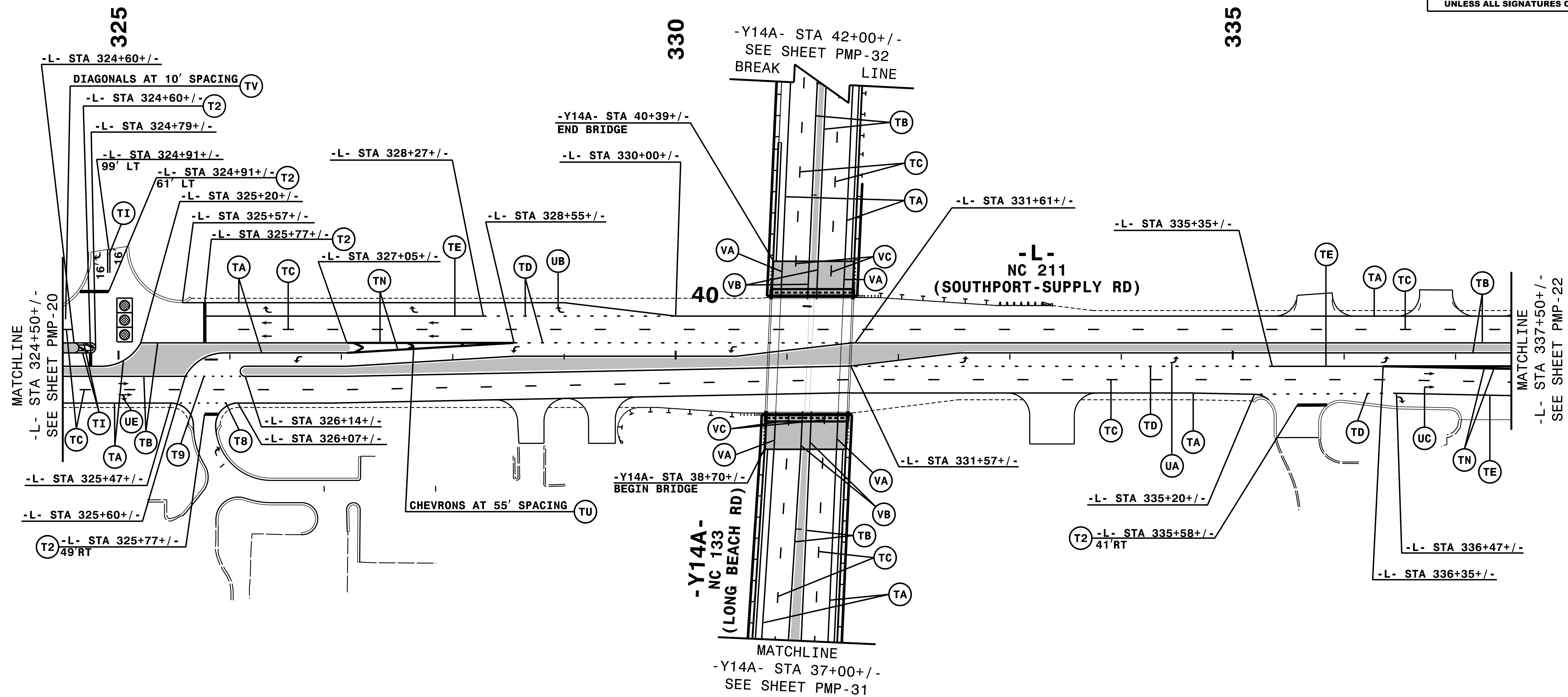

NOTE: ALL LANE WIDTHS ARE 12' UNLESS OTHERWISE SHOWN.

9/2/2021
PMP-R5021_PMP_21.dgn
HNTB

HNTB

HNTB NORTH CAROLINA, P.C.
343 E. SIX FORKS ROAD, SUITE 200
RALEIGH, NORTH CAROLINA 27609
NC LICENSE NO: C-1554
(919) 546-6997

PAVEMENT MARKING DETAIL

TIP NO. R-5021	SHEET NO. PMP-22
APPROVED: <i>Andrew D. Klimesiek</i> E3078FB459E44B	
DATE: 9/2/2021	
SEAL	
	
DOCUMENT NOT CONSIDERED FINAL UNLESS ALL SIGNATURES COMPLETED	

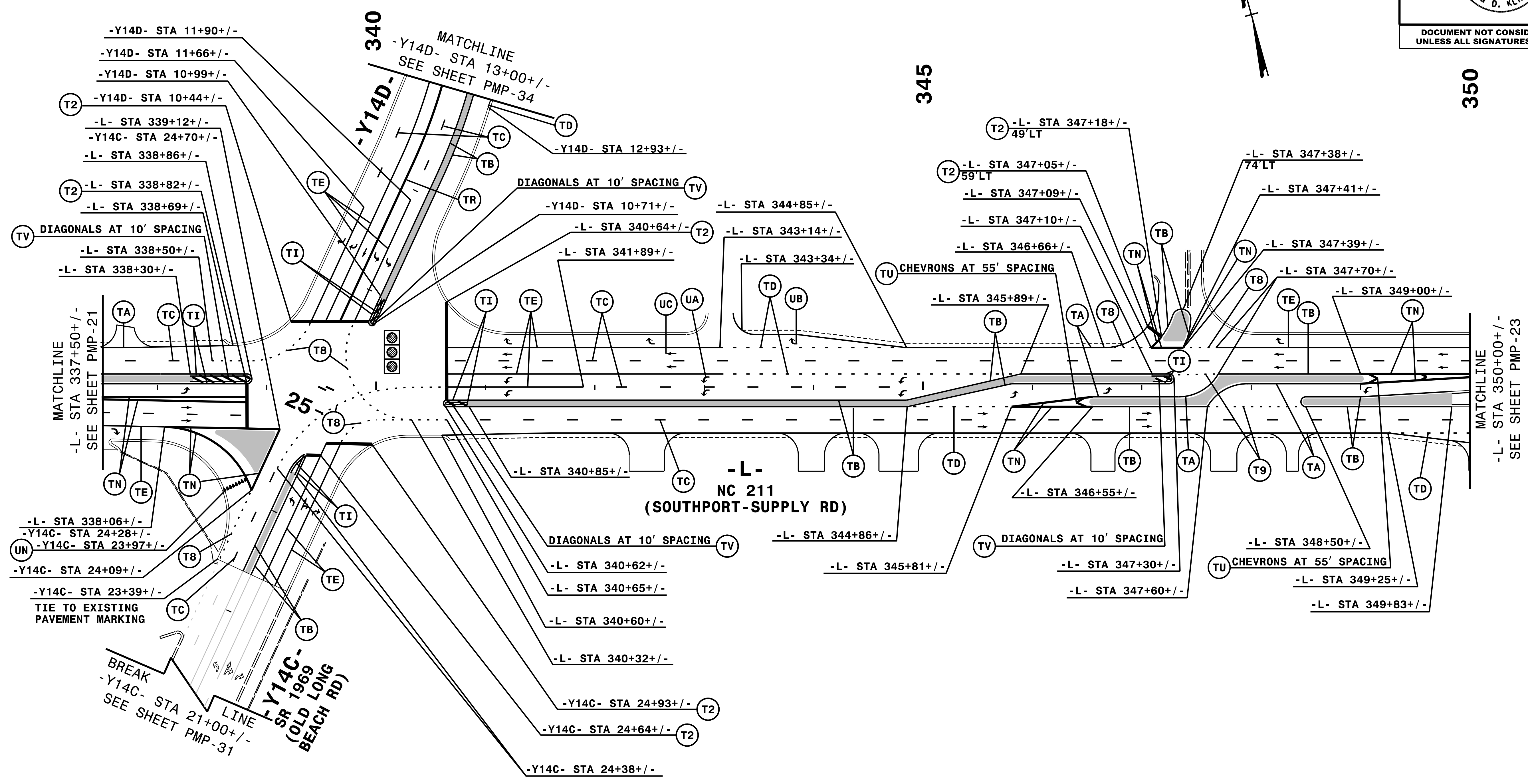

NOTE: ALL LANE WIDTHS ARE 12' UNLESS OTHERWISE SHOWN.

9/2/2021
PMP-R5021_PMP_22.dgn
HNTB

HNTB
 HNTB NORTH CAROLINA, P.C.
 343 E. Six Forks Road, Suite 200
 Raleigh, North Carolina 27609
 NC License No: C-1554
 (919) 546-8997

PAVEMENT MARKING DETAIL

TIP NO. R-5021	SHEET NO. PMP-23
APPROVED: <i>Andrew D. Klincksiek</i> E-3078FB4596E44B	
DATE: 9/2/2021	
	
DOCUMENT NOT CONSIDERED FINAL UNLESS ALL SIGNATURES COMPLETED	

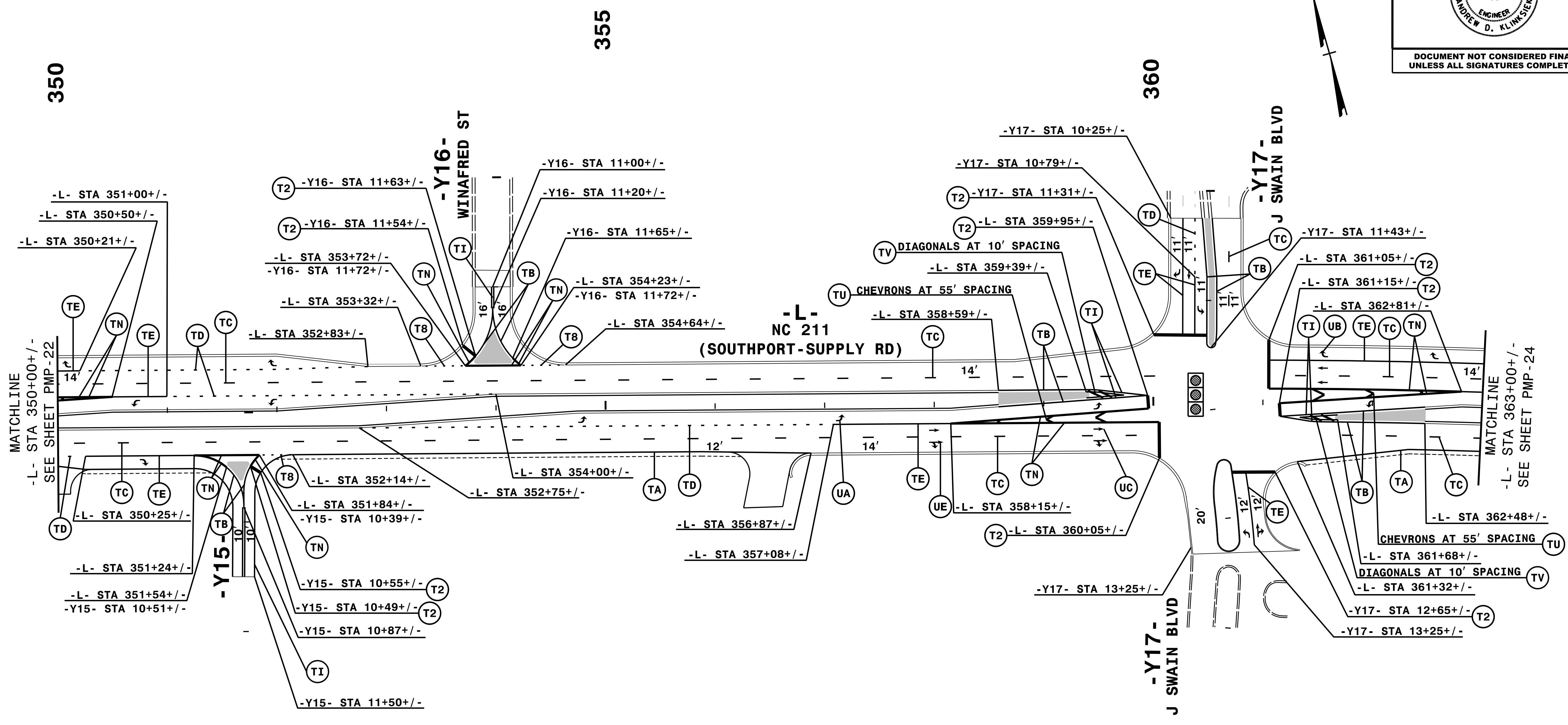

NOTE: ALL LANE WIDTHS ARE 12' UNLESS OTHERWISE SHOWN.

9/2/2021
PMP-R5021_PMP_23.dgn
HNTB

HNTB

HNTB NORTH CAROLINA, P.C.
343 E. Six Forks Road, Suite 200
Raleigh, North Carolina 27609
NC License No: C-1554
(919) 546-8997

PAVEMENT MARKING DETAIL

TIP NO. R-5021	SHEET NO. PMP-24
APPROVED: <i>Andrew D. Klincksiek</i> E3078FB459E44B	
DATE: 9/2/2021	
	
DOCUMENT NOT CONSIDERED FINAL UNLESS ALL SIGNATURES COMPLETED	

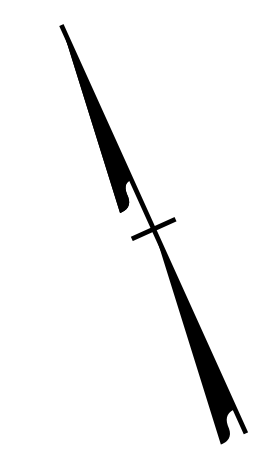
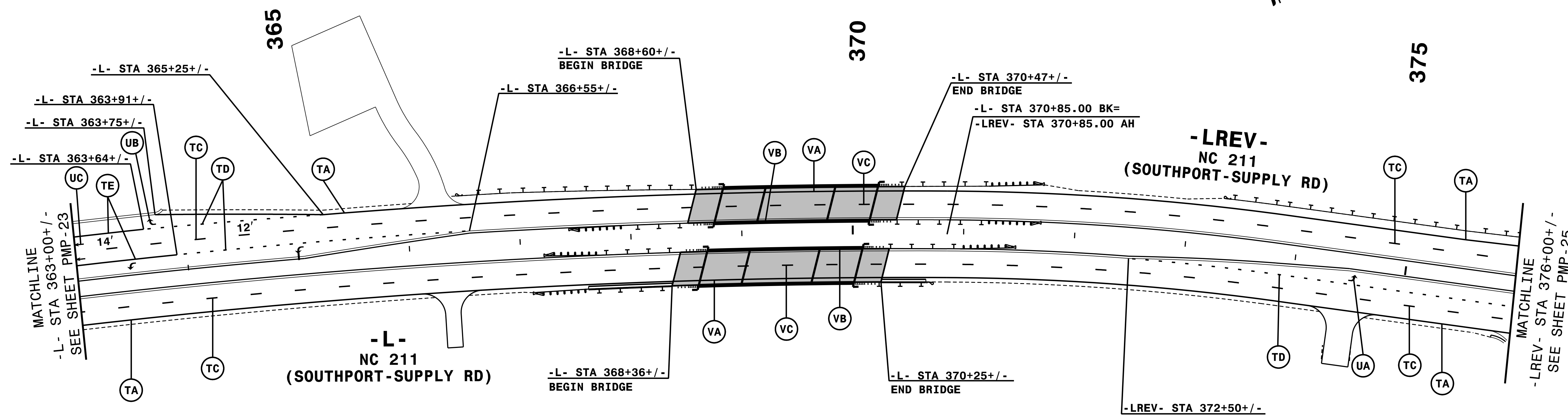

NOTE: ALL LANE WIDTHS ARE 12' UNLESS OTHERWISE SHOWN.

9/2/2021
PMP-R5021_PMP_24.dgn
HNTB

HNTB
 HNTB NORTH CAROLINA, P.C.
 343 E. SIX FORKS ROAD, SUITE 200
 RALEIGH, NORTH CAROLINA 27609
 NC LICENSE NO: C-1554
 (919) 546-8997

PAVEMENT MARKING DETAIL

TIP NO. R-5021	SHEET NO. PMP-25
APPROVED: <i>Andrew D. Klinck</i> E3078FB459644B	
DATE: 9/2/2021	
SEAL 	
DOCUMENT NOT CONSIDERED FINAL UNLESS ALL SIGNATURES COMPLETED	

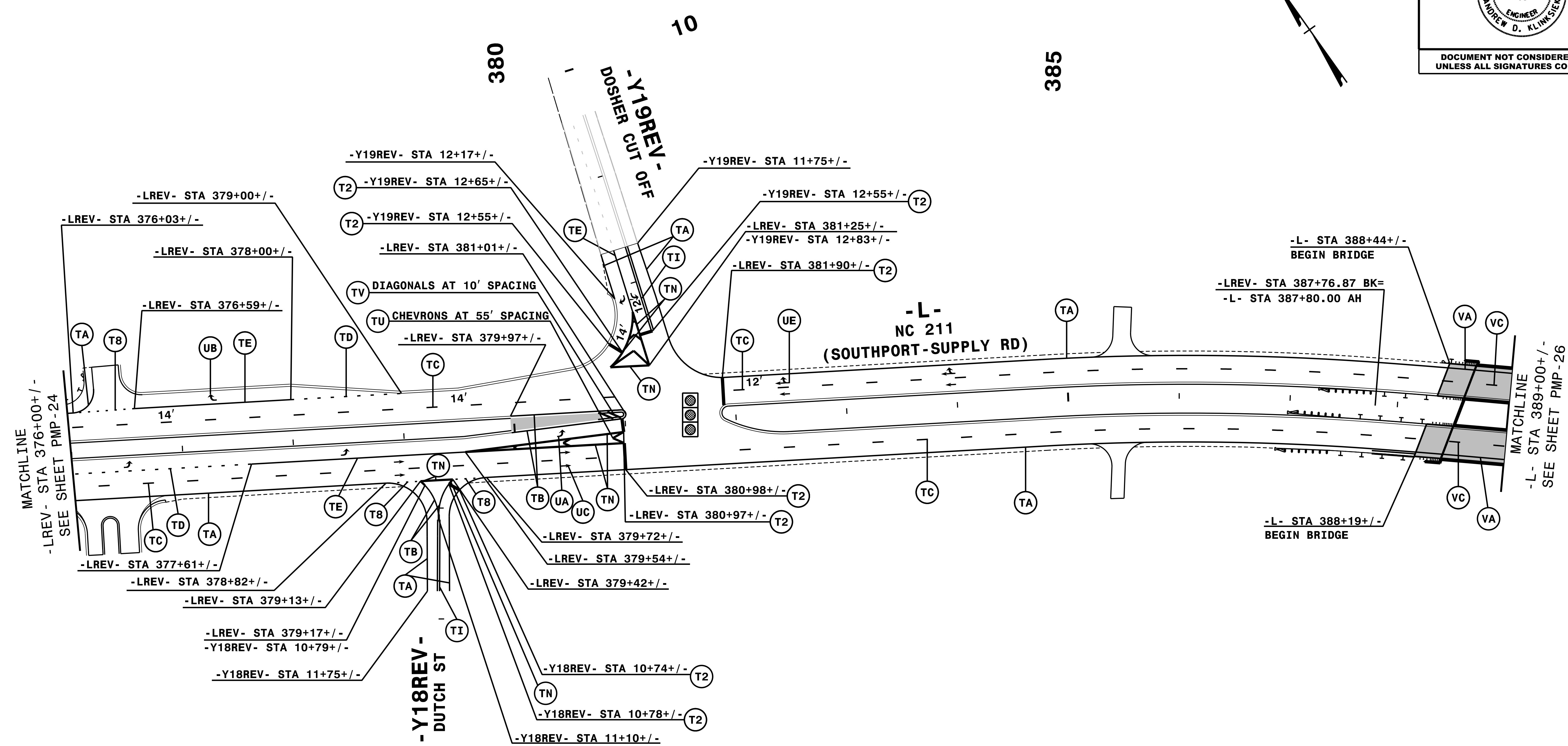

NOTE: ALL LANE WIDTHS ARE 12' UNLESS OTHERWISE SHOWN.

9/2/2021
PMP-R5021_PMP_25.dgn
HNTB

HNTB
 HNTB NORTH CAROLINA, P.C.
 343 E. Six Forks Road, Suite 200
 Raleigh, North Carolina 27609
 NC License No: C-1554
 (919) 546-8997

PAVEMENT MARKING DETAIL

TIP NO. R-5021	SHEET NO. PMP-26
APPROVED: <i>Andrew D. Klincksiek</i> <small>ES078FB4596E44B</small>	
DATE: 9/2/2021	
SEAL	
	
DOCUMENT NOT CONSIDERED FINAL UNLESS ALL SIGNATURES COMPLETED	

CURB RAMP LOCATIONS

① -L- STA 399+33+/- 46.5' RT (TYPE 1)

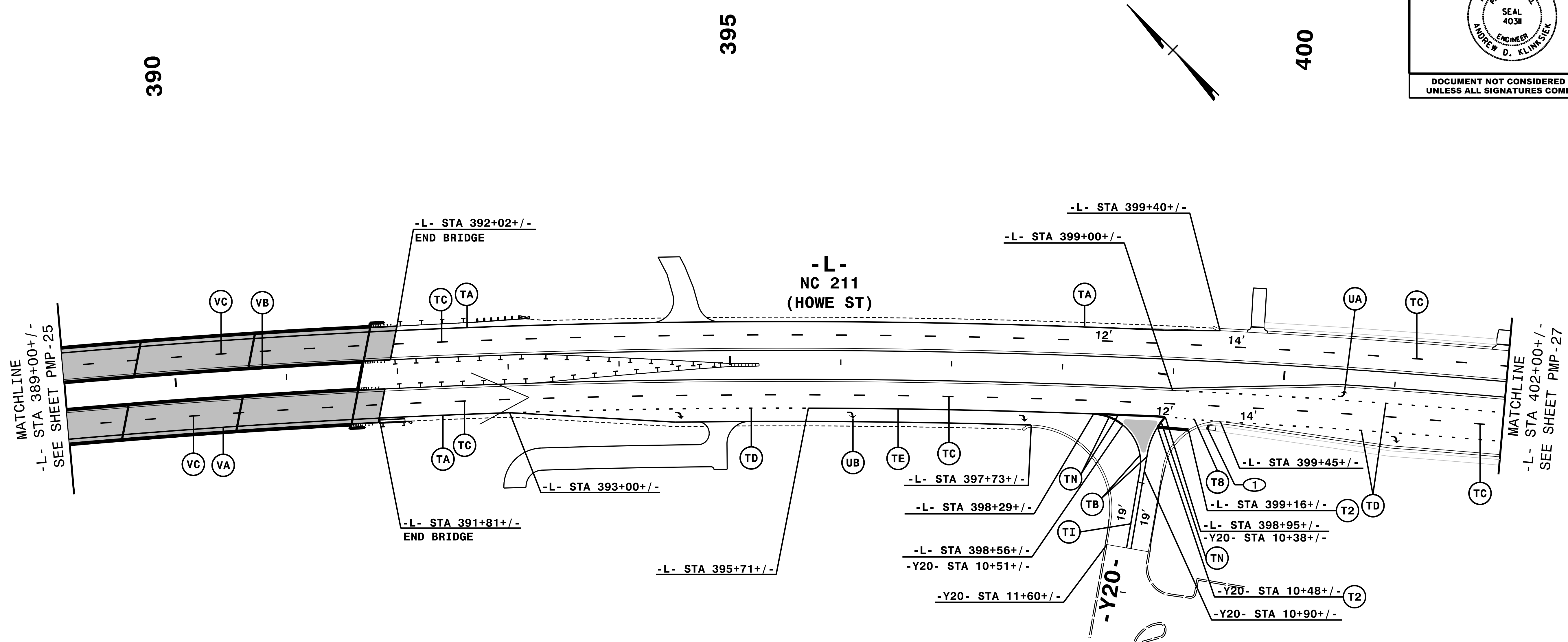

NOTE: ALL LANE WIDTHS ARE 12' UNLESS OTHERWISE SHOWN.

HNTB
 HNTB NORTH CAROLINA, P.C.
 343 E. Six Forks Road, Suite 200
 Raleigh, North Carolina 27609
 NC License No: C-1554
 (919) 546-8997

PAVEMENT MARKING DETAIL

9/2/2021
 P:\PMP\R5021_PMP_pmp_26.dgn
 HNTB

TIP NO. R-5021	SHEET NO. PMP-30
APPROVED: <i>Andrew D. Klinck</i> <small>E3078FB499E44B</small>	
DATE: 10/28/2021	
SEAL 	
DOCUMENT NOT CONSIDERED FINAL UNLESS ALL SIGNATURES COMPLETED	

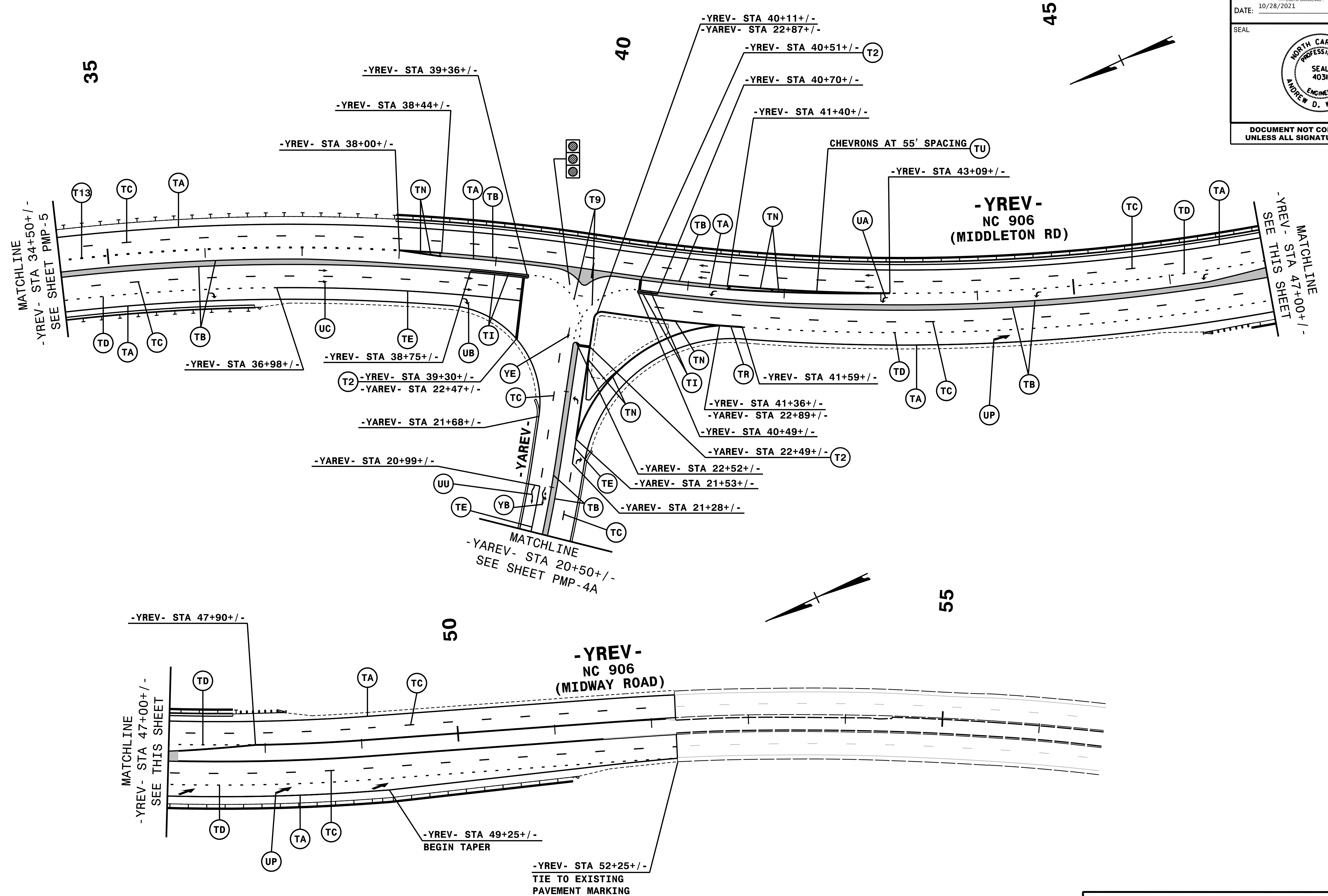

NOTE: ALL LANE WIDTHS ARE 12' UNLESS OTHERWISE SHOWN.

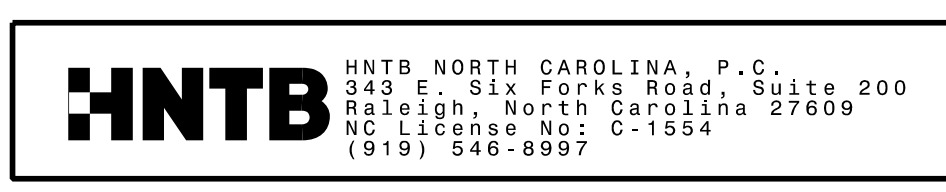

PAVEMENT MARKING DETAIL

10/28/2021 10:28:21 AM P:\PMP\R5021_PMP_pmp_30.dgn HNTB

APPROVED: Andrew D. Klincksiek
DATE: 9/2/2021

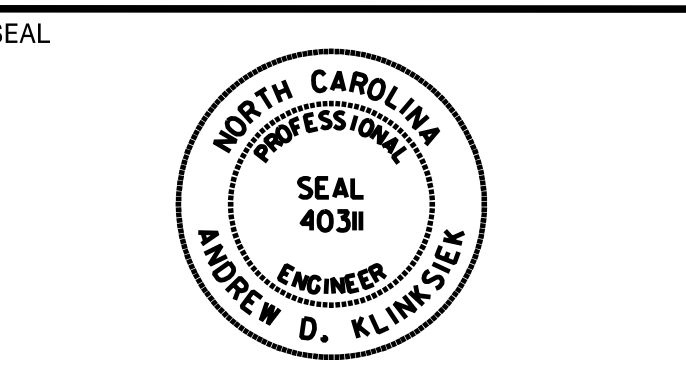

DOCUMENT NOT CONSIDERED FINAL UNLESS ALL SIGNATURES COMPLETED

- CURB RAMP LOCATIONS**
- 14 -L- STA 415+10+/- 48.00 RT (TYPE 1)
 - 15 -L- STA 415+43+/- 48.00 RT (TYPE 1)
 - 16 -L- STA 420+35+/- 48.00 RT (TYPE 1)
 - 17 -L- STA 420+80+/- 48.00 RT (TYPE 1)
 - 18 -L- STA 422+56+/- 48.00 RT (TYPE 1)
 - 19 -L- STA 422+99+/- 48.49 RT (TYPE 1)
 - 20 -L- STA 423+60+/- 48.04 RT (TYPE 1)
 - 21 -L- STA 424+09+/- 48.00 RT (TYPE 1)
 - 22 -L- STA 424+30+/- 43.04 RT (STANDARD)
 - 23 -L- STA 424+65+/- 60.78 RT (STANDARD)
 - 24 -L- STA 425+17+/- 60.72 RT (STANDARD)
 - 25 -L- STA 425+98+/- 35.08 RT (TYPE 1)
 - 26 -L- STA 426+44+/- 33.94 RT (TYPE 1)
 - 27 -L- STA 426+86+/- 32.88 RT (TYPE 1)

- CURB RAMP LOCATIONS**
- 28 -L- STA 427+27+/- 31.87 RT (TYPE 1)
 - 29 -L- STA 425+42+/- 63.95 LT (STANDARD)
 - 30 -L- STA 424+39+/- 70.82 LT (STANDARD)
 - 31 -L- STA 424+30+/- 62.19 LT (STANDARD)
 - 32 -L- STA 422+62+/- 48.00 LT (TYPE 1)
 - 33 -L- STA 422+25+/- 48.00 LT (TYPE 1)
 - 34 -L- STA 421+70+/- 48.00 LT (TYPE 1)
 - 35 -L- STA 421+26+/- 48.00 LT (TYPE 1)
 - 36 -L- STA 420+29+/- 48.00 LT (TYPE 1)
 - 37 -L- STA 419+84+/- 48.00 LT (TYPE 1)
 - 38 -L- STA 428+54+/- 28.69 RT (TYPE 1)
 - 39 -L- STA 429+25+/- 27.00 RT (TYPE 1)
 - 40 -L- STA 429+92+/- 27.25 RT (TYPE 1)
 - 41 -L- STA 429+51+/- 39.56 LT (TYPE 1)

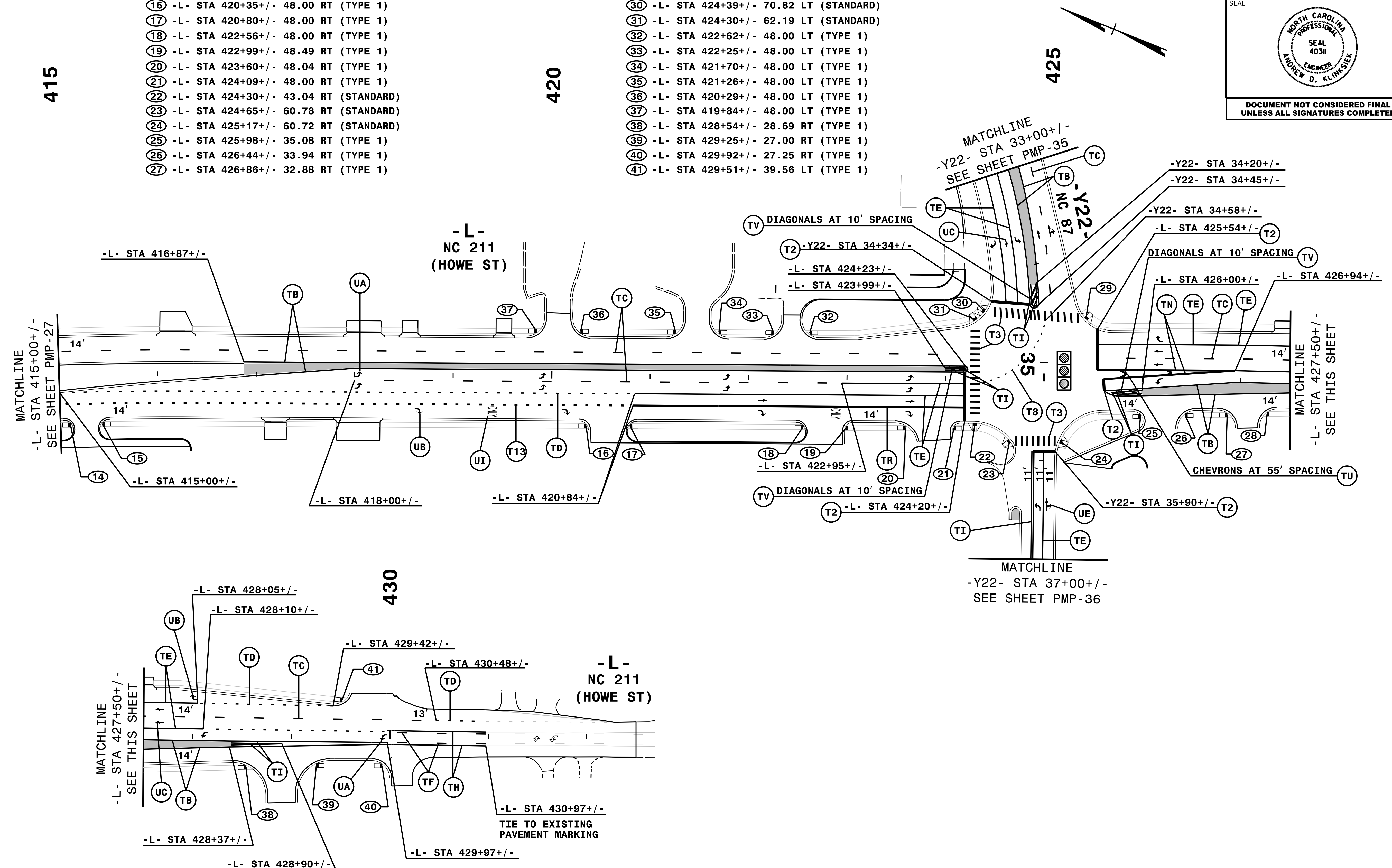

NOTE: ALL CROSSWALK WIDTHS ARE 10' UNLESS OTHERWISE SHOWN.

NOTE: ALL LANE WIDTHS ARE 12' UNLESS OTHERWISE SHOWN.

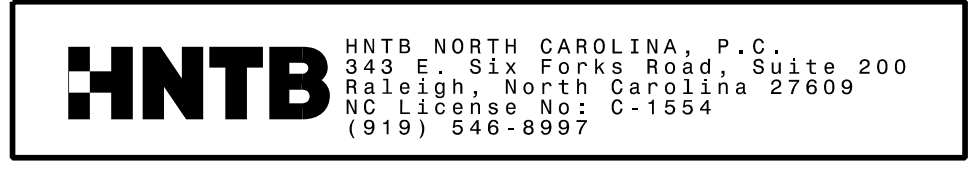

PAVEMENT MARKING DETAIL

9/2/2021
PMP-R5021_PMP_28.dgn
HNTB

TIP NO. R-5021	SHEET NO. PMP-29
-------------------	---------------------

APPROVED: *Andrew D. Klincksiek*
DocuSigned by:
 Andrew D. Klincksiek
 e3078f8459644b...
 DATE: 9/2/2021



DOCUMENT NOT CONSIDERED FINAL
 UNLESS ALL SIGNATURES COMPLETED

-YREV- STA 10+70+/-
 TIE TO EXISTING
 PAVEMENT MARKING

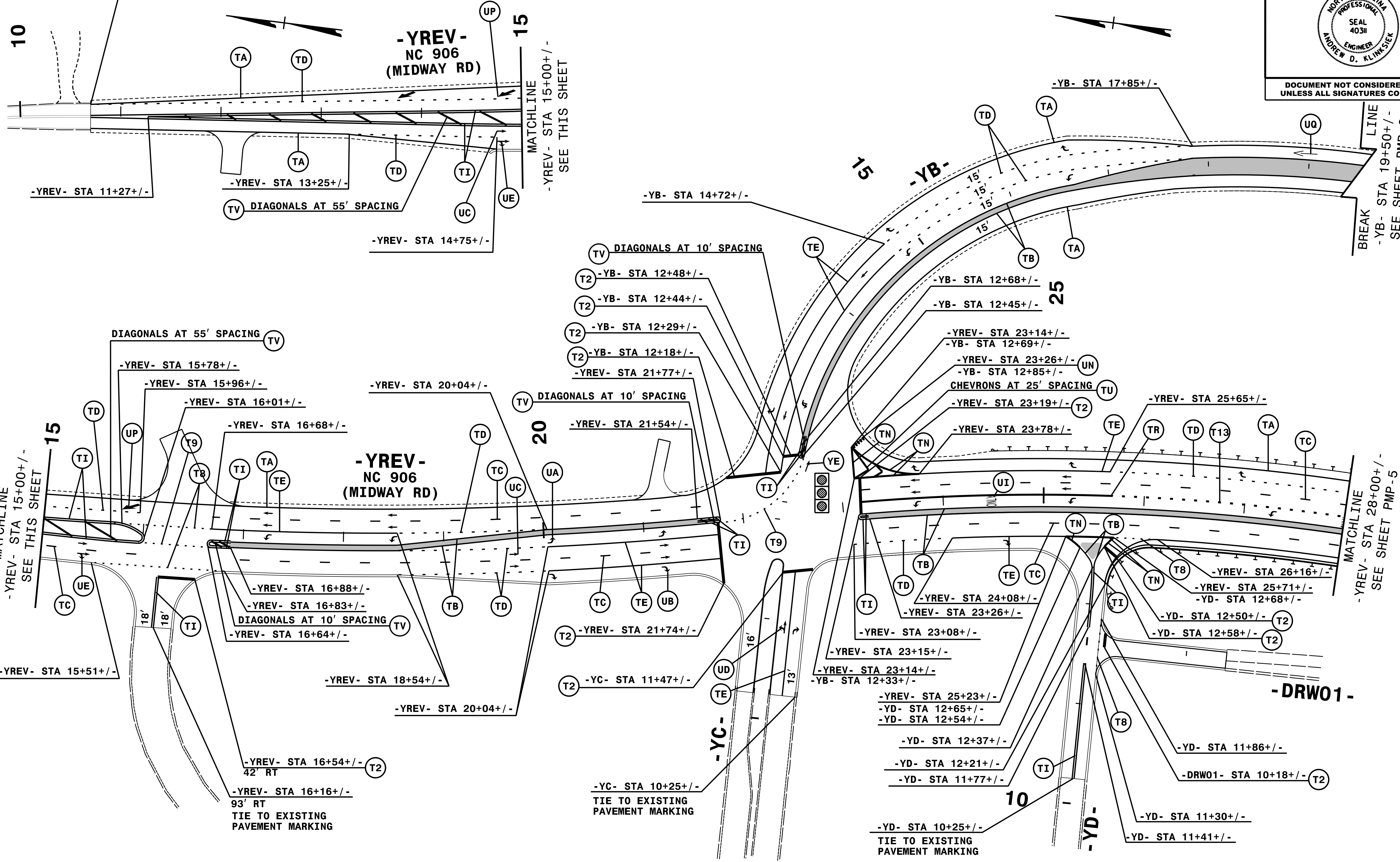

NOTE: ALL LANE WIDTHS ARE 12' UNLESS OTHERWISE SHOWN.

HNTB
HNTB NORTH CAROLINA, P.C.
 343 E. Six Forks Road, Suite 200
 Raleigh, North Carolina 27609
 NC License No: C-1554
 (919) 546-8997

PAVEMENT MARKING DETAIL

9/2/2021
 PMP-R5021_PMP_29.dgn
 HNTB

TIP NO. R-5021	SHEET NO. PMP-31
APPROVED: <i>Andrew D. Klincksiek</i> <small>ES078FB4596E44B</small>	
DATE: 9/2/2021	
SEAL 	
DOCUMENT NOT CONSIDERED FINAL UNLESS ALL SIGNATURES COMPLETED	

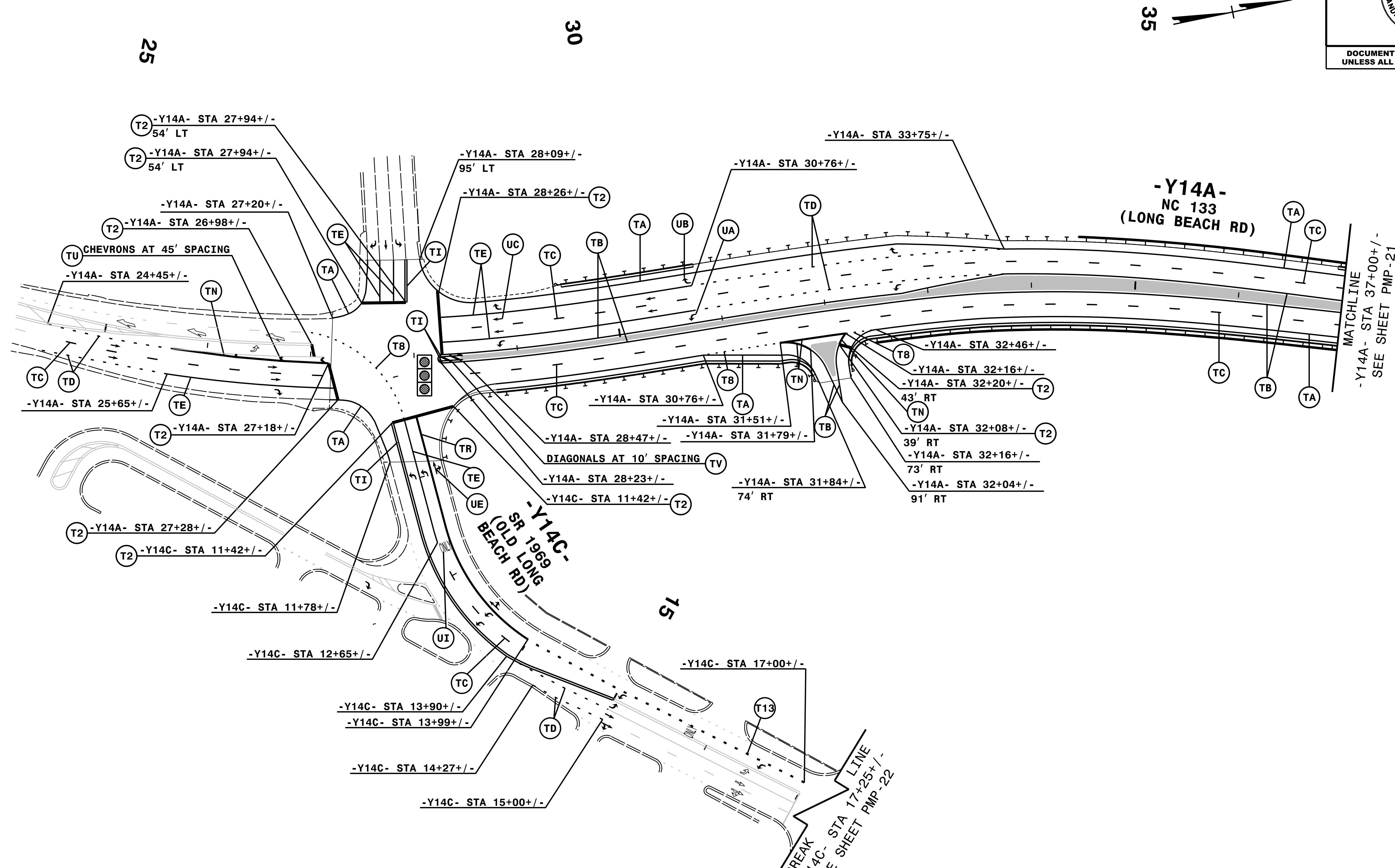

NOTE: ALL LANE WIDTHS ARE 12' UNLESS OTHERWISE SHOWN.

9/2/2021
PMP-R5021_PMP_pmp_31.dgn
HNTB

HNTB
 HNTB NORTH CAROLINA, P.C.
 343 E. Six Forks Road, Suite 200
 Raleigh, North Carolina 27609
 NC License No: C-1554
 (919) 546-8997

PAVEMENT MARKING DETAIL

TIP NO. R-5021	SHEET NO. PMP-32
APPROVED: <i>Andrew D. Klincksiek</i> <small>ES078FB4596E44B</small>	
DATE: 9/2/2021	
	
DOCUMENT NOT CONSIDERED FINAL UNLESS ALL SIGNATURES COMPLETED	

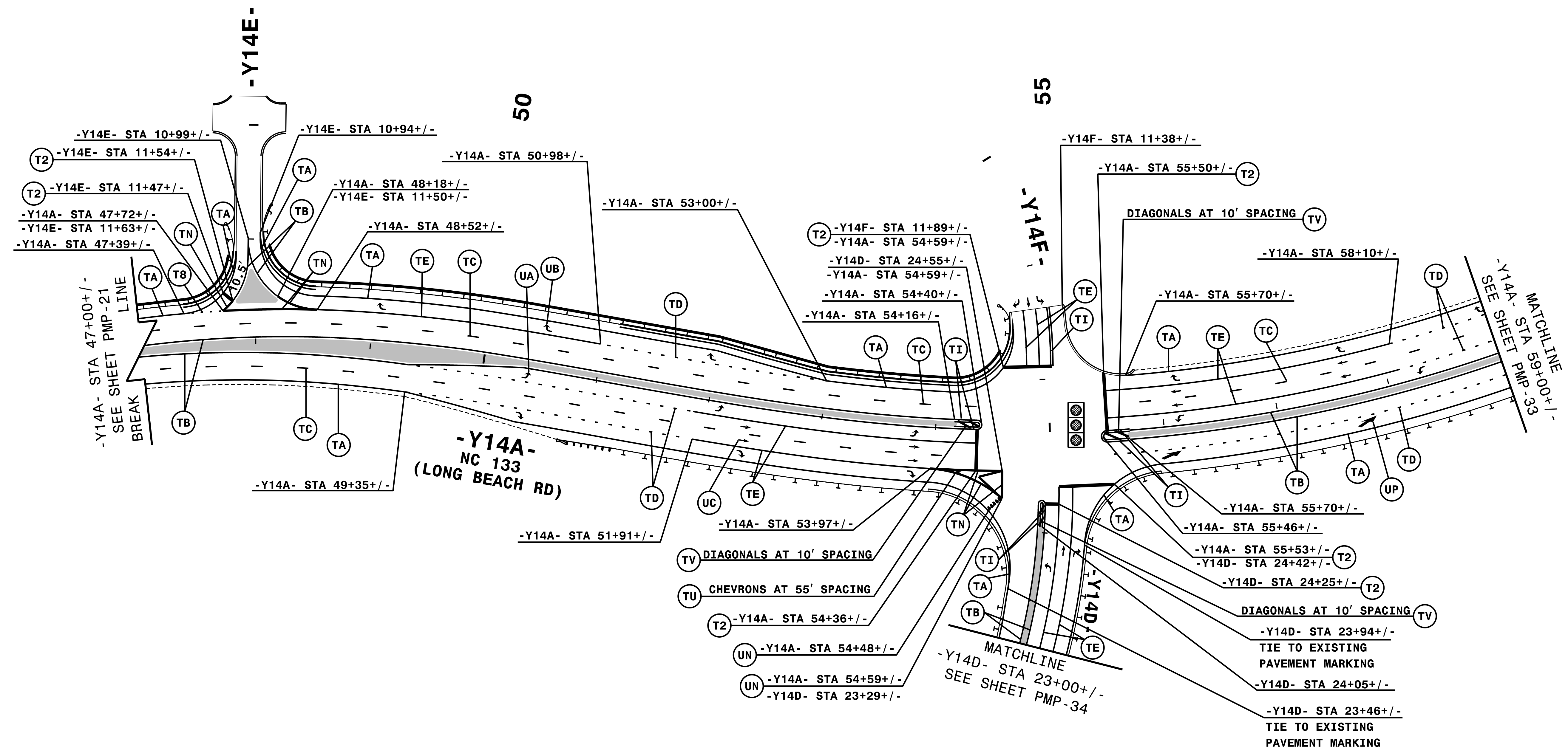
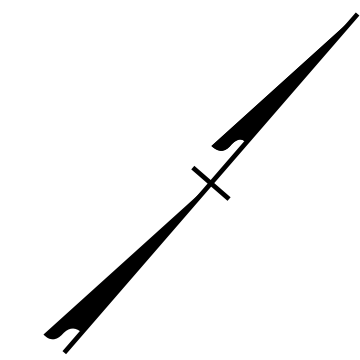

NOTE: ALL LANE WIDTHS ARE 12' UNLESS OTHERWISE SHOWN.

9/2/2021
PMP-R5021_PMP_pmp_32.dgn
HNTB

HNTB
HNTB NORTH CAROLINA, P.C.
 343 E. Six Forks Road, Suite 200
 Raleigh, North Carolina 27609
 NC License No: C-1554
 (919) 546-8997

PAVEMENT MARKING DETAIL

TIP NO. R-5021	SHEET NO. PMP-33
APPROVED: <u>Andrew D. Klincksiek</u> <small>DocuSigned by: E3D78FB4596E44B...</small>	
DATE: 9/2/2021	
SEAL 	
DOCUMENT NOT CONSIDERED FINAL UNLESS ALL SIGNATURES COMPLETED	

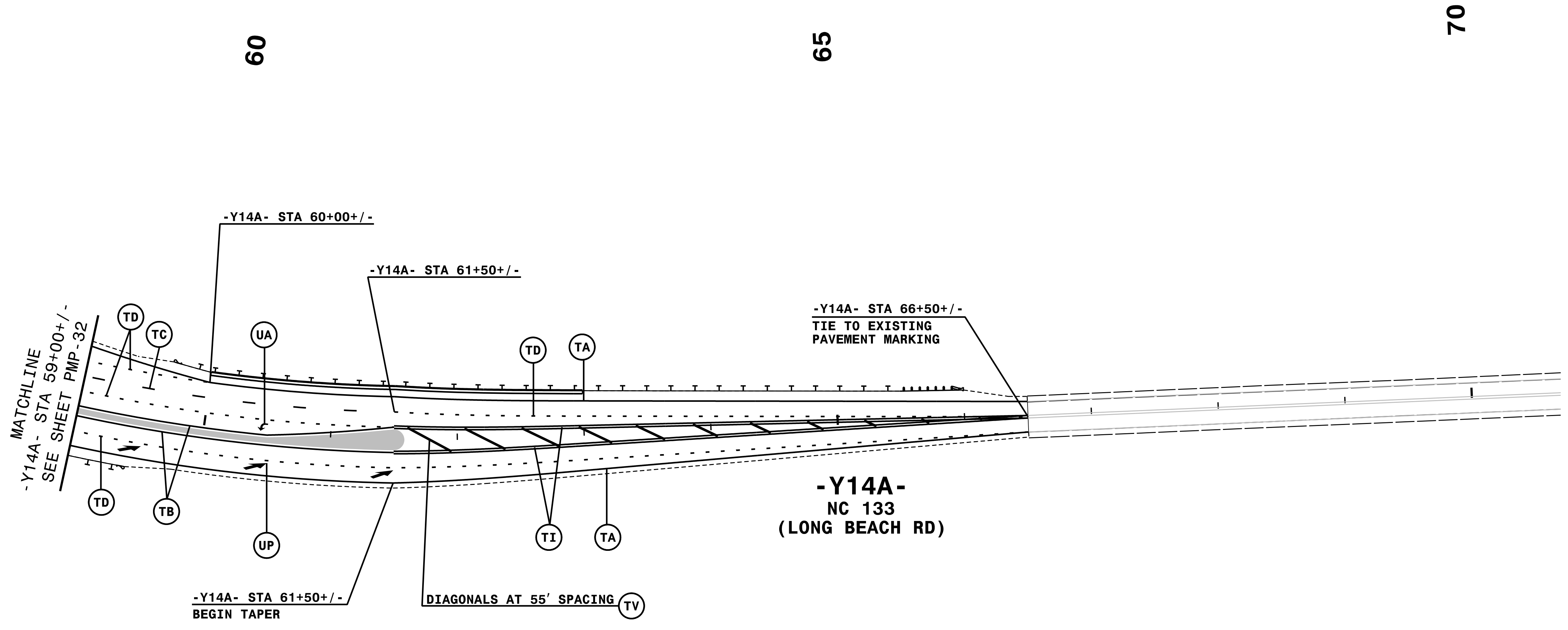
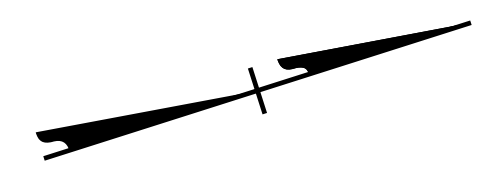

NOTE: ALL LANE WIDTHS ARE 12' UNLESS OTHERWISE SHOWN.

9/2/2021
PMP-R5021_PMP_33.dgn
HNTB

HNTB
 HNTB NORTH CAROLINA, P.C.
 343 E. SIX FORKS ROAD, SUITE 200
 RALEIGH, NORTH CAROLINA 27609
 NC LICENSE NO: C-1554
 (919) 546-8997

PAVEMENT MARKING DETAIL

TIP NO. R-5021	SHEET NO. PMP-34
APPROVED: <i>Andrew D. Klinck</i> <small>DocuSigned by: Andrew D. Klinck E3D78FB459E44B...</small>	
DATE: 9/2/2021	
SEAL 	
DOCUMENT NOT CONSIDERED FINAL UNLESS ALL SIGNATURES COMPLETED	

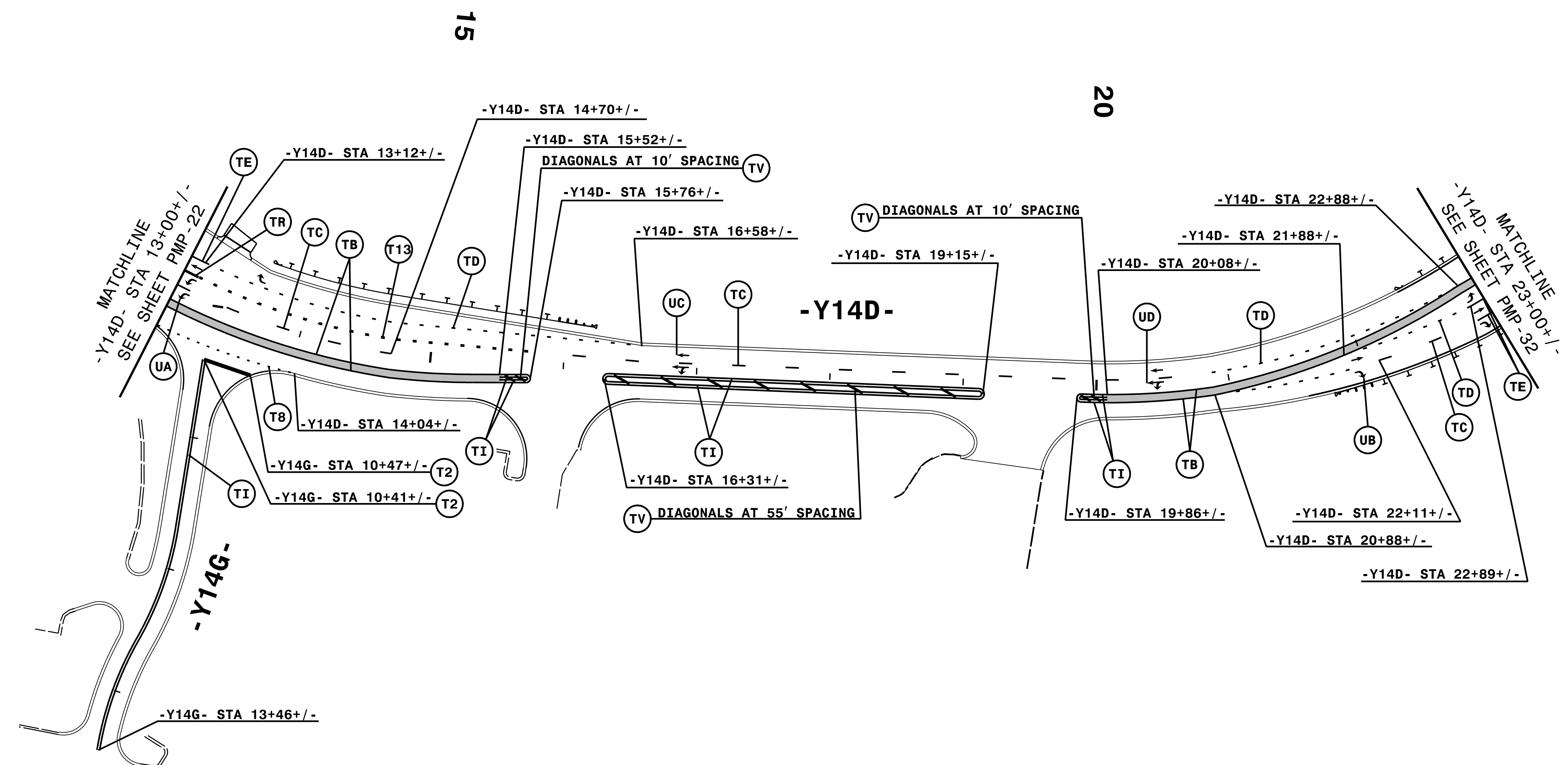

NOTE: ALL LANE WIDTHS ARE 12' UNLESS OTHERWISE SHOWN.

HNTB
HNTB NORTH CAROLINA, P.C.
343 E. Six Forks Road, Suite 200
Raleigh, North Carolina 27609
NC License No: C-1554
(919) 546-8997

PAVEMENT MARKING DETAIL

9/2/2021
PMP-R5021_PMP_34.dgn
HNTB

TIP NO. R-5021	SHEET NO. PMP-35
APPROVED: <i>Andrew D. Klincksiek</i> E3078FB4596E44B	
DATE: 9/2/2021	
SEAL 	
DOCUMENT NOT CONSIDERED FINAL UNLESS ALL SIGNATURES COMPLETED	

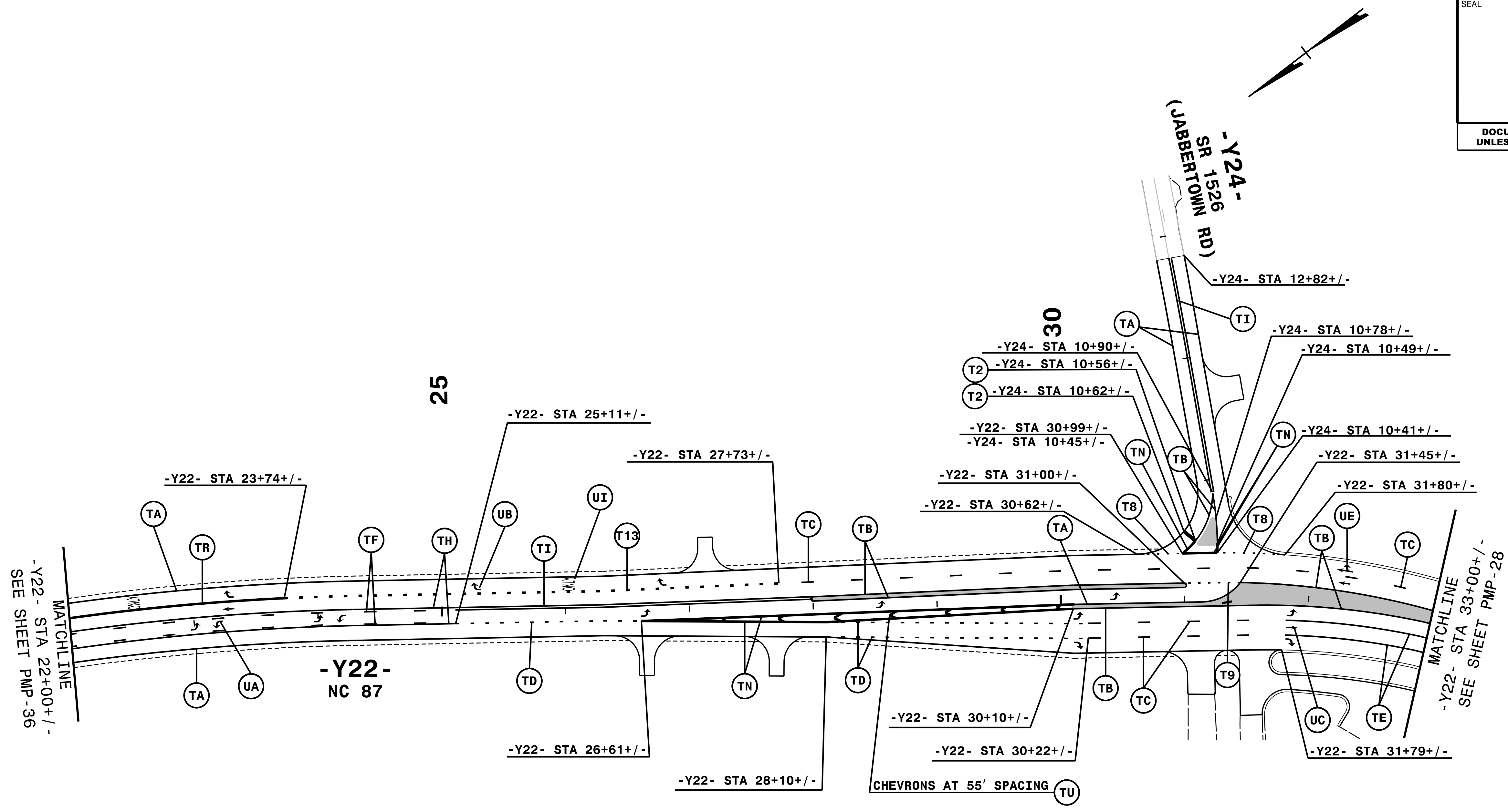

NOTE: ALL LANE WIDTHS ARE 12' UNLESS OTHERWISE SHOWN.

HNTB
 HNTB NORTH CAROLINA, P.C.
 343 E. Six Forks Road, Suite 200
 Raleigh, North Carolina 27609
 NC License No: C-1554
 (919) 546-8997

PAVEMENT MARKING DETAIL

9/2/2021
PMP-R5021_PMP_pmp_35.dgn
HNTB

TIP NO. R-5021	SHEET NO. PMP-36
APPROVED: <i>Andrew D. Klincksiek</i> E3078FB459E44B	
DATE: 9/2/2021	
	
DOCUMENT NOT CONSIDERED FINAL UNLESS ALL SIGNATURES COMPLETED	

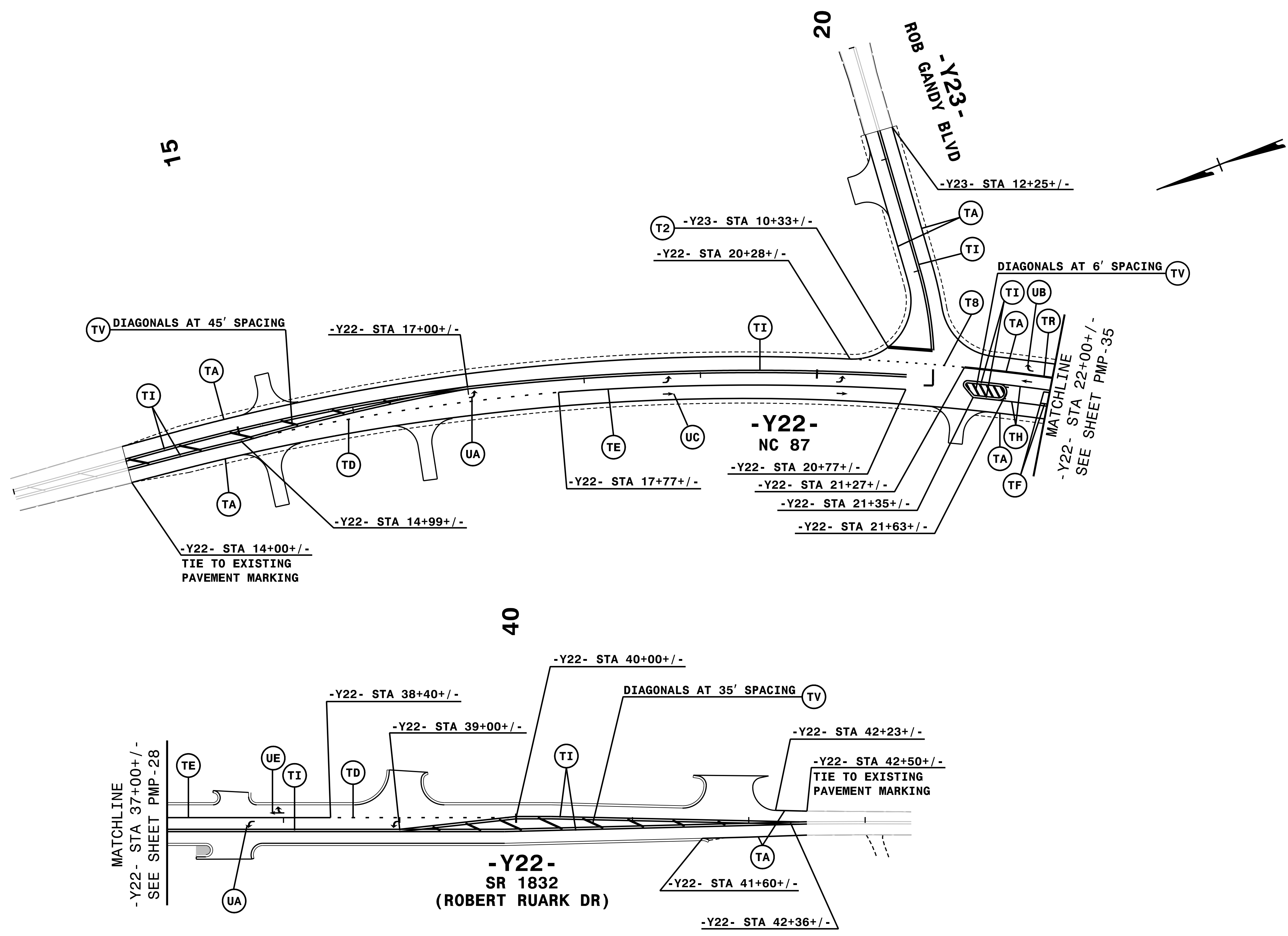

NOTE: ALL LANE WIDTHS ARE 12' UNLESS OTHERWISE SHOWN.

9/2/2021
PMP-R5021_PMP_36.dgn
HNTB

HNTB
 HNTB NORTH CAROLINA, P.C.
 343 E. Six Forks Road, Suite 200
 Raleigh, North Carolina 27609
 NC License No: C-1554
 (919) 546-8997

PAVEMENT MARKING DETAIL