

EDI MODEL 2018ECL-NC CONFLICT MONITOR PROGRAMMING DETAIL

(remove jumpers and set switches as shown)

REMOVE DIODE JUMPERS 1-5, 1-6, 1-9, 1-11, 2-5, 2-6, 2-9, 2-11, 3-7, 3-8, 3-10, 3-12, 4-7, 4-8, 4-10, 4-12, 5-9, 5-11, 6-9, 6-11, 7-10, 7-12, 8-10, 8-12, 9-11 and 10-12.

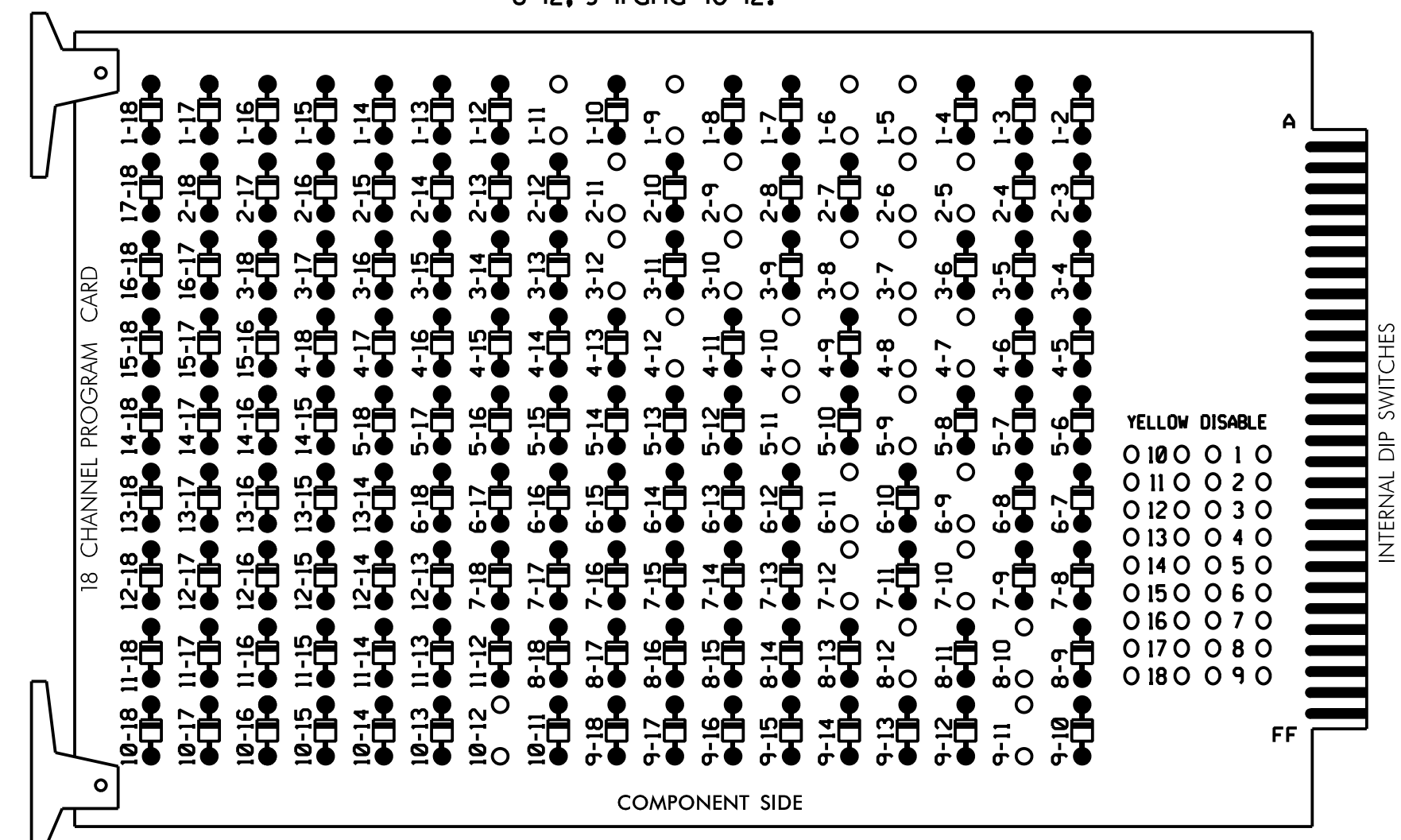

NOTES:

- Card is provided with all diode jumpers in place. Removal of any jumper allows its channels to run concurrently.
- Ensure jumpers SEL2-SEL5 and SEL9 are present on the monitor board.
- Ensure that Red Enable is active at all times during normal operation.
- Connect serial cable from conflict monitor to comm. port 1 of 2070 controller. Ensure conflict monitor communicates with 2070.

REMOVE JUMPERS AS SHOWN

NOTES

- To prevent "flash-conflict" problems, insert red flash program blocks for all unused vehicle load switches in the output file. The installer shall verify that signal heads flash in accordance with the Signal Plans.
- Program phases 4 and 8 for Dual Entry.
- Enable Simultaneous Gap-Out for all Phases.
- Program phases 2 and 6 for Startup In Green.
- Program phases 2 and 6 for Yellow Flash, and overlaps 1 and 2 as Wag Overlaps.
- If this signal will be managed by an ATMS software, enable controller and detector logging for all detectors used at this location.
- The cabinet and controller are part of the NC 133 Closed Loop System.

EQUIPMENT INFORMATION

CONTROLLER.....2070E
 CABINET.....332 W/ AUX
 SOFTWARE.....ECONOLITE OASIS
 CABINET MOUNT.....BASE
 OUTPUT FILE POSITIONS...18 WITH AUX. OUTPUT FILE
 LOAD SWITCHES USED.....S1,S2,S4,S5,S7,S8,S10,S11,
 AUX S1,AUX S2,AUX S4,AUX S5
 PHASES USED.....1,2,3,4,5,6,7,8
 OVERLAP "A".....1+2
 OVERLAP "B".....3+4
 OVERLAP "C".....5+6
 OVERLAP "D".....7+8

SIGNAL HEAD HOOK-UP CHART

LOAD SWITCH NO.	S1	S2	S3	S4	S5	S6	S7	S8	S9	S10	S11	S12	AUX S1	AUX S2	AUX S3	AUX S4	AUX S5	AUX S6	
CMU CHANNEL NO.	1	2	13	3	4	14	5	6	15	7	8	16	9	10	17	11	12	18	
PHASE	1	2	2 PED	3	4	4 PED	5	6	6 PED	7	8	8 PED	OLA	OLB	SPARE	OLC	OLD	SPARE	
SIGNAL HEAD NO.	11	21,22	NU	31	41,42	NU	42	51	61,62	NU	71	81,82	NU	11	31	NU	51	71	
RED		128			101		*		134			107							
YELLOW	*	129		*	102				135		*	108							
GREEN		130			103				136			109							
RED ARROW																A121	A124	A114	A101
YELLOW ARROW																A122	A125	A115	A102
FLASHING YELLOW ARROW																A123	A126	A116	A103
GREEN ARROW	127			118			133	133			124								

NU = Not Used

* Denotes install load resistor. See load resistor installation detail this sheet.

★ See pictorial of head wiring in detail this sheet.

INPUT FILE POSITION LAYOUT

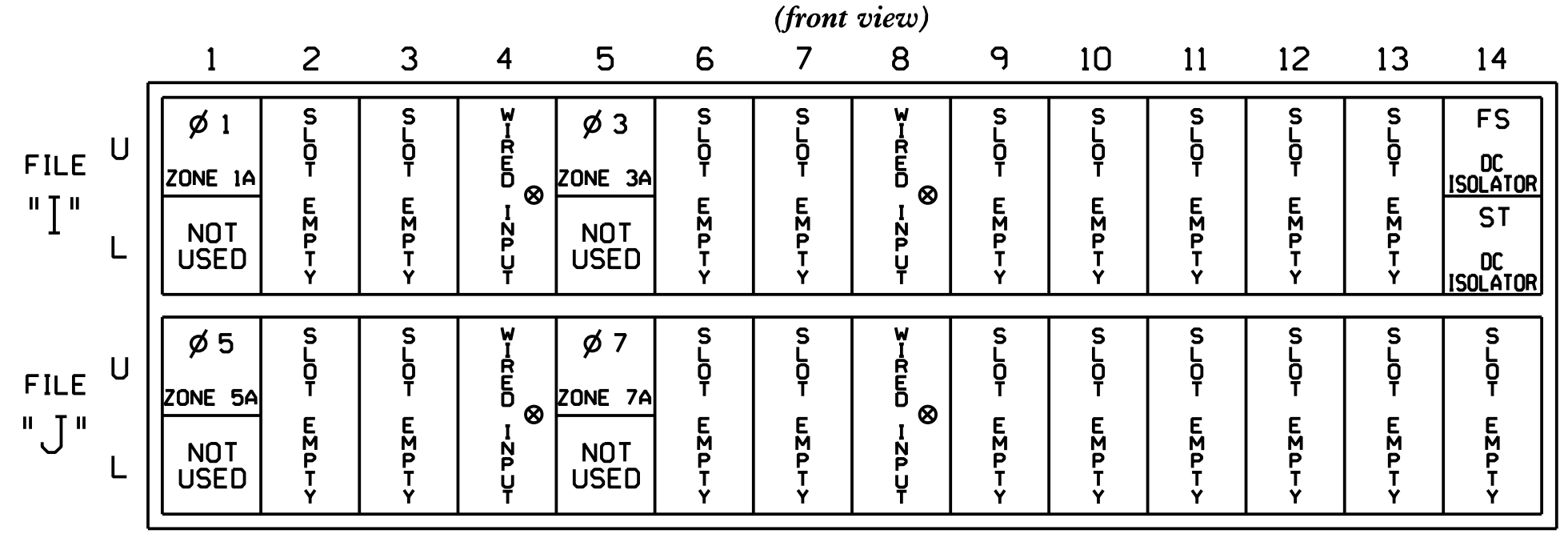

EX.: 1A, 2A, ETC. = LOOP NO.'S

FS = FLASH SENSE
 ST = STOP TIME

INPUT FILE CONNECTION & PROGRAMMING CHART

LOOP NO.	LOOP TERMINAL	INPUT FILE POS.	PIN NO.	INPUT ASSIGNMENT NO.	DETECTOR NO.	NEMA PHASE	CALL	EXTEND	FULL TIME DELAY	STRETCH TIME	DELAY TIME
ZONE 1A ¹	TB2-1,2	I1U	56	18	1	1	Y	Y			15
	-	J4U	48	10★	26	6	Y	Y			
ZONE 3A ²	TB4-5,6	I5U	58	20	3	3	Y	Y			15
	-	J8U	50	12★	28	8	Y	Y			3
ZONE 5A ³	TB3-1,2	J1U	55	17	5	5	Y	Y			15
	-	J1U	55	17★	55	5	Y	Y			
ZONE 7A ⁴	TB5-5,6	J5U	57	19	7	7	Y	Y			15
	-	I8U	49	11★	24	4	Y	Y			
		J5U	57	19★	57	7	Y	Y			

- Add jumper from I1-W to J4-W, on rear of input file.
 - Add jumper from I5-W to J8-W, on rear of input file.
 - Add jumper from J1-W to I4-W, on rear of input file.
 - Add jumper from J5-W to I8-W, on rear of input file.
- * See Input Page Assignment programming details on sheets 4, 5, 6, and 7.

INPUT FILE POSITION LEGEND: J2L

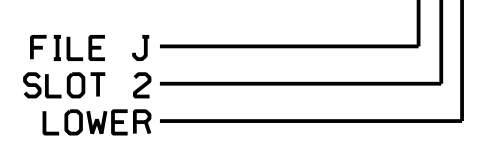

LOAD RESISTOR INSTALLATION DETAIL

(install resistors as shown)

VALUE (ohms)	WATTAGE
1.5K - 1.9K	25W (min)
2.0K - 3.0K	10W (min)

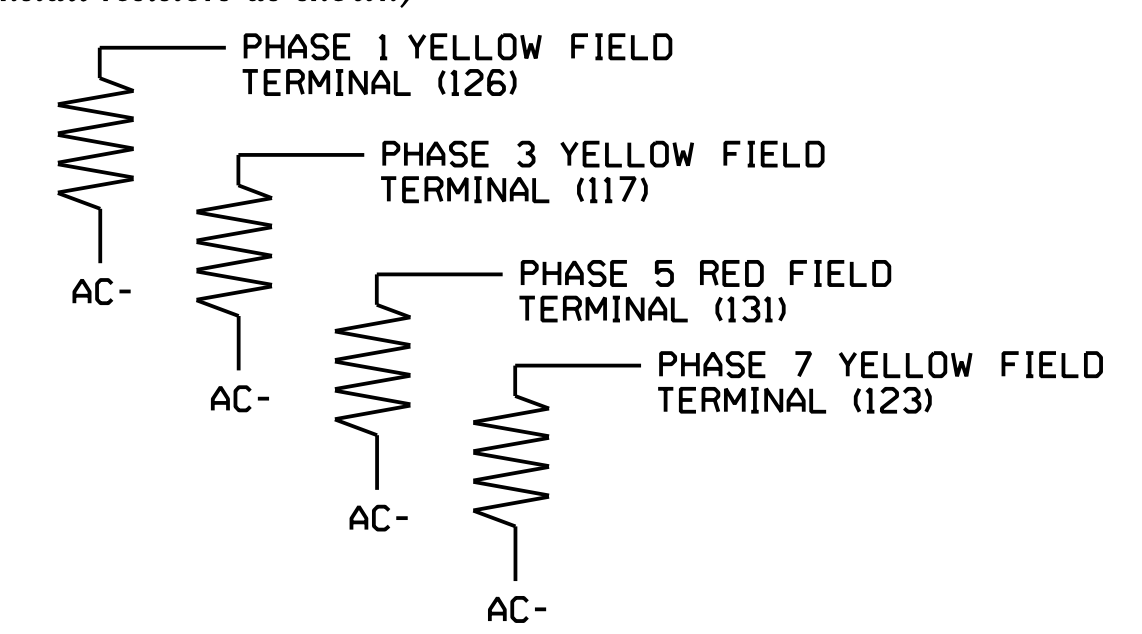

SPECIAL DETECTOR NOTE

Install a microwave detection system for vehicle detection. Perform installation according to manufacturer's directions and NCDOT engineer-approved mounting locations to accomplish the detection schemes shown on the Signal Design Plans.

For loops 1A, 3A, 5A, and 7A, detector card placement and slots reserved for wired inputs are typical for a NCDOT installation. Inputs associated with these slots are compatible with time of day instructions located on sheets 4, 5, 6, 7, and 8 of this electrical detail.



HNTB NORTH CAROLINA, P.C.
 343 E. Six Forks Road, Suite 200
 Raleigh, North Carolina 27609
 NC License No: C-1564
 (919) 546-8997

FYA SIGNAL WIRING DETAIL

(wire signal heads as shown)

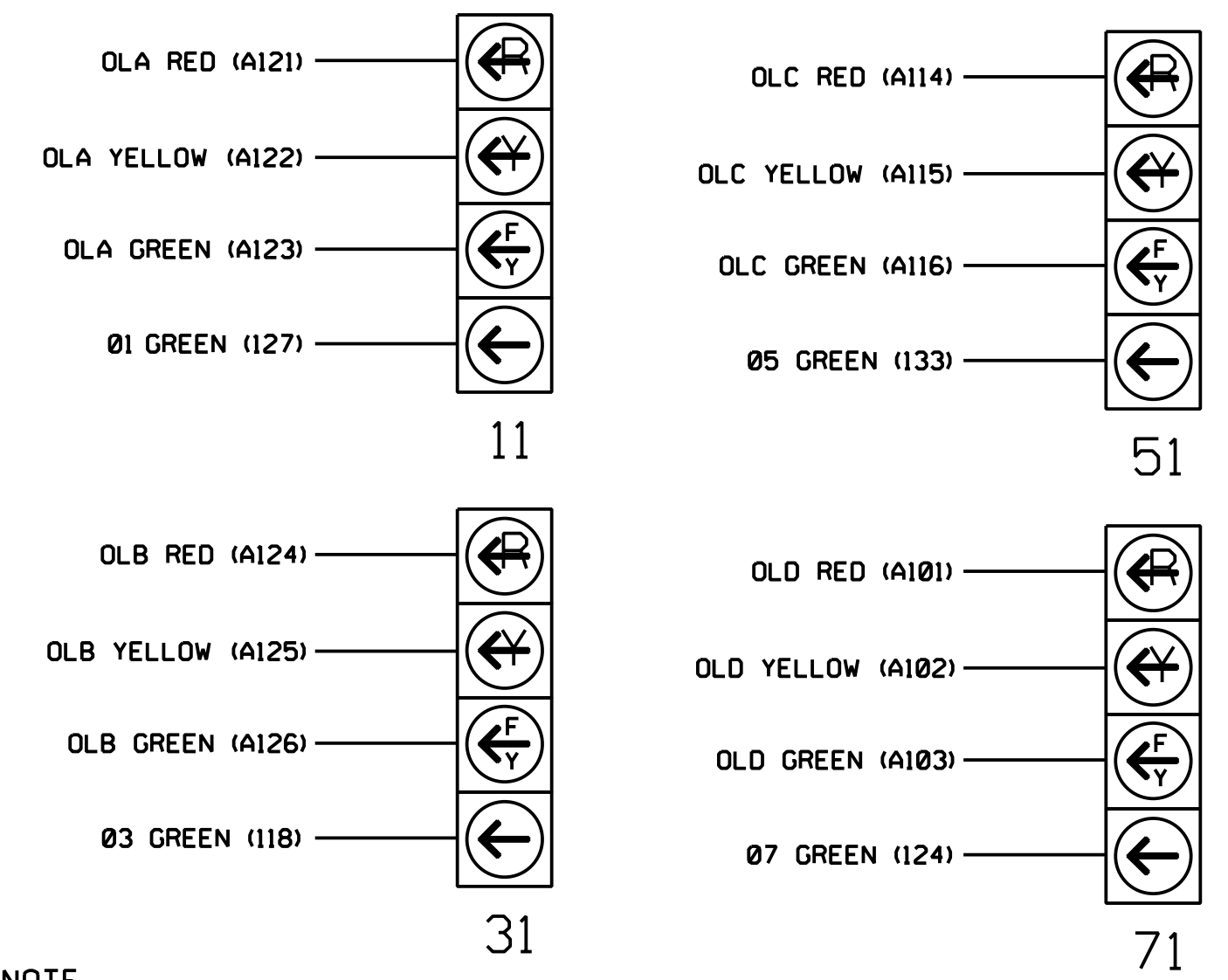

NOTE

The sequence display for signal heads 11, 31, 51, and 71 requires special logic programming. See sheet 2 for programming instructions.

THIS ELECTRICAL DETAIL IS FOR THE SIGNAL DESIGN: 03-0215T4
 DESIGNED: June 2017
 SEALED: 9/10/2021
 REVISED: N/A

Electrical Detail - Sheet 1 of 8
 Signal Upgrade
 Temporary Design 4

DOCUMENT NOT CONSIDERED FINAL UNLESS ALL SIGNATURES COMPLETED

	Prepared for: Department of Transportation Division 03	NC 211 (Howe Street) at NC 87 (River Road)/ SR 1852 (Robert Ruark Drive) Brunswick Co., Southport	SEAL
	PLAN DATE: June 2017 PREPARED BY: A.H. Thornburg	REVIEWED BY: A.D. Klinskiak REVIEWED BY: N.R. Simmons	Revisions table with columns for Revisions, Init., and Date.