

### EDI MODEL 2018ECL-NC CONFLICT MONITOR PROGRAMMING DETAIL

(remove jumpers and set switches as shown)

REMOVE DIODE JUMPERS 2-5, 2-6, 2-11, 5-11, and 6-11.

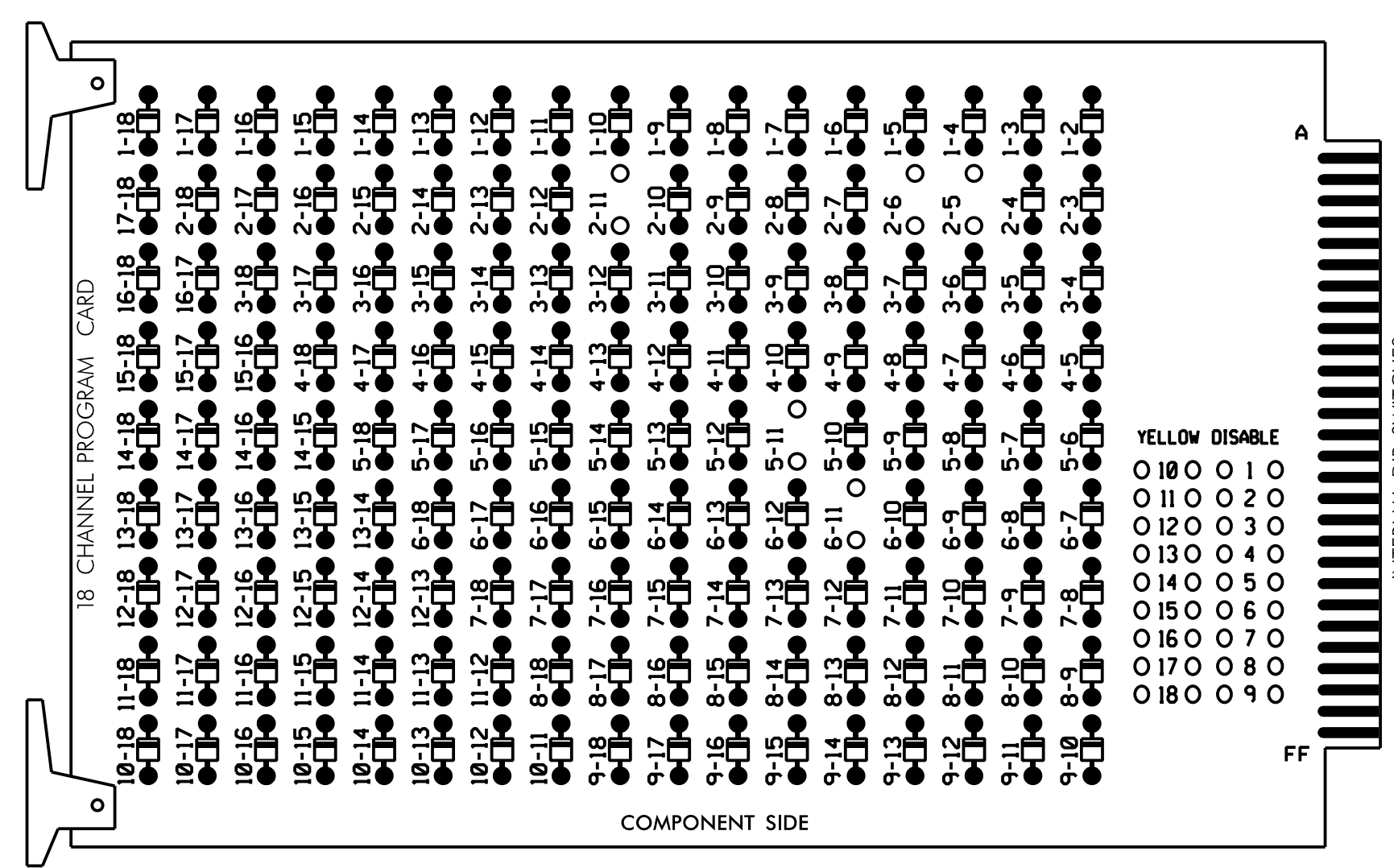

REMOVE JUMPERS AS SHOWN

**NOTES:**

1. Card is provided with all diode jumpers in place. Removal of any jumper allows its channels to run concurrently.
2. Ensure jumpers SEL2-SEL5 and SEL9 are present on the monitor board.
3. Ensure that Red Enable is active at all times during normal operation.
4. Connect serial cable from conflict monitor to comm. port 1 of 2070 controller. Ensure conflict monitor communicates with 2070.

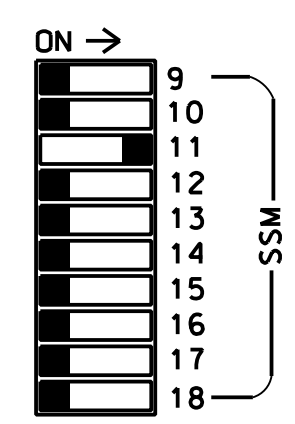
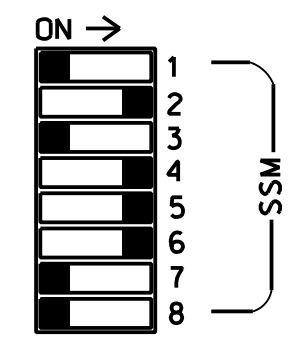
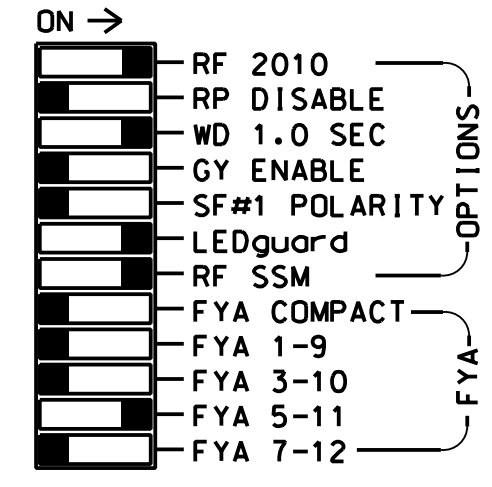
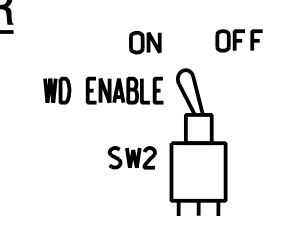

■ = DENOTES POSITION OF SWITCH

### NOTES

1. To prevent "flash-conflict" problems, insert red flash program blocks for all unused vehicle load switches in the output file. The installer shall verify that signal heads flash in accordance with the Signal Plans.
2. Enable Simultaneous Gap-Out for all Phases.
3. Program phases 2 and 6 for Variable Initial and Gap Reduction.
4. Program phases 2 and 6 for Startup In Green.
5. Program phases 2 and 6 for Yellow Flash.
6. If this signal will be managed by an ATMS software, enable controller and detector logging for all detectors used at this location.
7. The cabinet and controller are part of the NC 133 Closed Loop System.

### EQUIPMENT INFORMATION

CONTROLLER.....2070E  
 CABINET.....332 W/AUX  
 SOFTWARE.....ECONOLITE OASIS  
 CABINET MOUNT.....BASE  
 OUTPUT FILE POSITIONS...18 WITH AUX. OUTPUT FILE  
 LOAD SWITCHES USED.....S2,S5,S7,S8,AUX S4  
 PHASES USED.....2,4,5,6  
 OVERLAP "A".....NOT USED  
 OVERLAP "B".....NOT USED  
 OVERLAP "C".....5+6  
 OVERLAP "D".....NOT USED

### SIGNAL HEAD HOOK-UP CHART

LOAD SWITCH NO.	S1	S2	S3	S4	S5	S6	S7	S8	S9	S10	S11	S12	AUX S1	AUX S2	AUX S3	AUX S4	AUX S5	AUX S6
CMU CHANNEL NO.	1	2	13	3	4	14	5	6	15	7	8	16	9	10	17	11	12	18
PHASE	1	2	2 PED	3	4	4 PED	5	6	6 PED	7	8	8 PED	OLA	OLB	SPARE	OLC	OLD	SPARE
SIGNAL HEAD NO.	NU	21,22	NU	NU	41,42	NU	42	51*	61,62	NU	NU	NU	NU	NU	NU	51	NU	NU
RED		128			101			*	134									
YELLOW		129			102				135									
GREEN		130			103				136									
RED ARROW																		A114
YELLOW ARROW							132											A115
FLASHING YELLOW ARROW																		A116
GREEN ARROW							133	133										

NU = Not Used

\* Denotes install load resistor. See load resistor installation detail this sheet.

★ See pictorial of head wiring in detail this sheet.

### INPUT FILE POSITION LAYOUT

(front view)

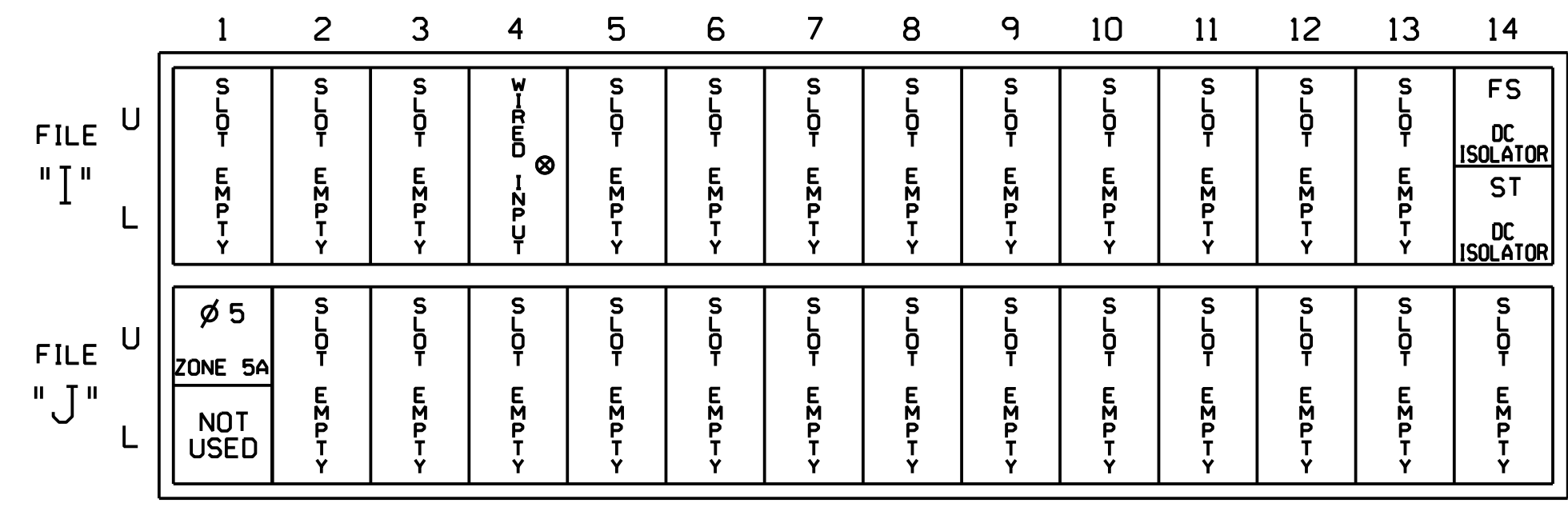

EX.: 1A, 2A, ETC. = LOOP NO.'S

FS = FLASH SENSE  
 ST = STOP TIME

⊗ Wired Input - Do not populate slot with detector card

### INPUT FILE CONNECTION & PROGRAMMING CHART

LOOP NO.	LOOP TERMINAL	INPUT FILE POS.	PIN NO.	INPUT ASSIGNMENT NO.	DETECTOR NO.	NEMA PHASE	CALL	EXTEND	FULL TIME DELAY	STRETCH TIME	DELAY TIME
ZONE 5A <sup>1</sup>	★★	J1U	55	17	5	5	Y	Y			15
	-	I4U	47	9★	22	2	Y	Y			
	-	J1U	55	17★	55	5	Y	Y			

<sup>1</sup>Add jumper from J1-W to I4-W, on rear of input file.

★ See vehicle detector setup programming detail for alternate phasing on sheet 3.

★★ Multizone Microwave Detector Zone. See Special Detector Note.

INPUT FILE POSITION LEGEND: J2L

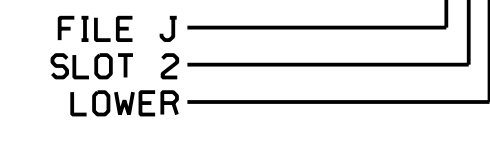

### FYA SIGNAL WIRING DETAIL

(wire signal head as shown)

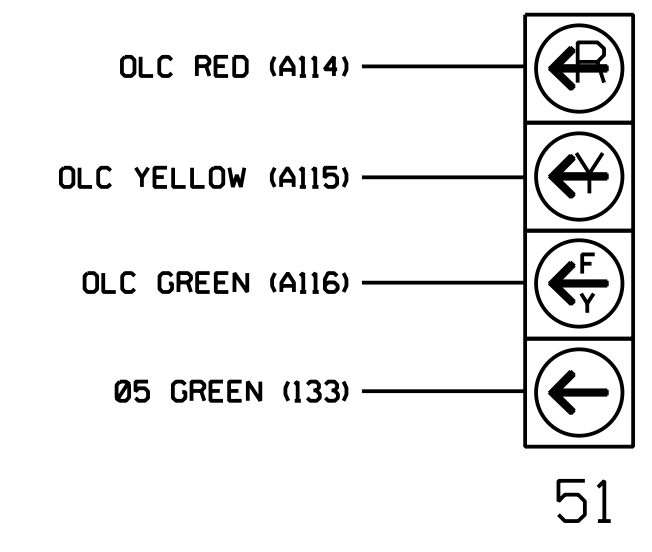

**NOTE**

The sequence display for signal head 51 requires special logic programming. See sheet 2 for programming instructions.

### SPECIAL DETECTOR NOTE

Install a microwave detection system for vehicle detection. Perform installation according to manufacturer's directions and NCDOT engineer-approved mounting locations to accomplish the detection schemes shown on the Signal Design Plans.

For loop 5A, detector card placement and slots reserved for wired inputs are typical for a NCDOT installation. Inputs associated with these slots are compatible with time of day instructions located on sheets 3 and 4 of this electrical detail.

### LOAD RESISTOR INSTALLATION DETAIL

(install resistor as shown)

VALUE (ohms)	WATTAGE
1.5K - 1.9K	25W (min)
2.0K - 3.0K	10W (min)

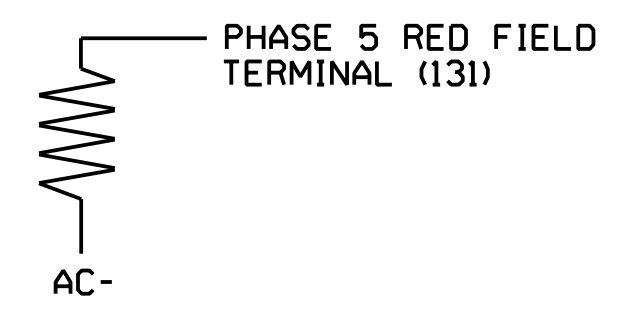

THIS ELECTRICAL DETAIL IS FOR THE SIGNAL DESIGN: 03-1125T1  
 DESIGNED: June 2017  
 SEALED: 9/10/2021  
 REVISED: N/A

Electrical Detail - Sheet 1 of 4  
 New Installation  
 Temporary Design 1

**DOCUMENT NOT CONSIDERED FINAL UNLESS ALL SIGNATURES COMPLETED**

	NC 133 (Long Beach Road) at SR 1969 (Old Long Beach Road) / Southport Crossing Entrance		
	Division 03 Brunswick Co. Southport	Prepared for:	
PLAN DATE: June 2017	REVIEWED BY: A.D. Klinksiek	Prepared by: A.H. Thornburg	
PREPARED BY: A.H. Thornburg	REVIEWED BY: N.R. Simmons	REVISIONS	INIT. DATE
HNTB NORTH CAROLINA, P.C. 343 E. Six Forks Road, Suite 200 Raleigh, North Carolina 27609 NC License No: C-1554 (919) 546-8997		Documented by: Natasha Simmons DATE: 9/10/2021 SIGNATURE: _____ DATE: _____ SIG. INVENTORY NO. 03-1125T1	