

09/08/99

PROJECT: 15614.1075010
CONTRACT: C204657

See Sheet 1A For Index of Sheets

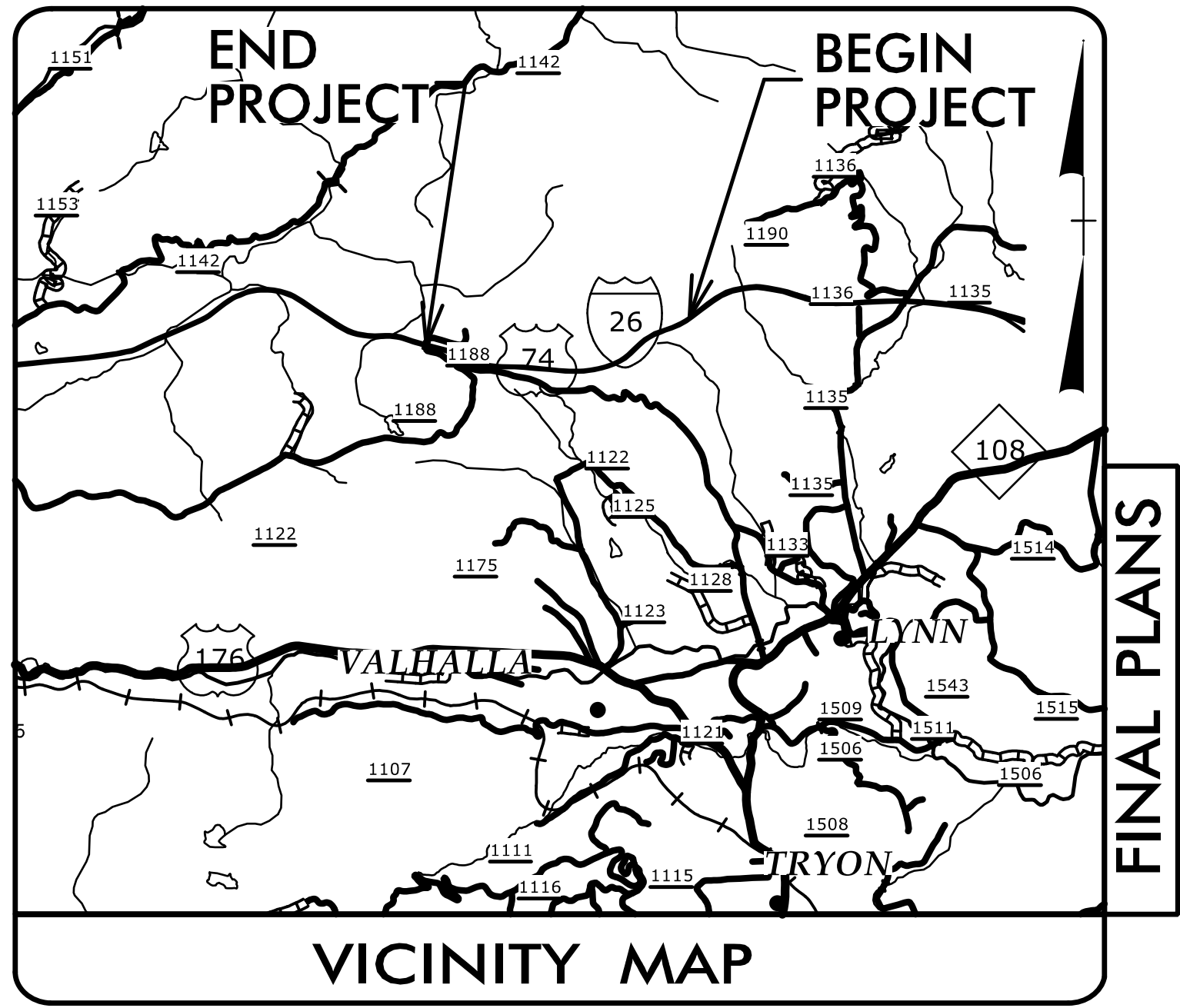

STATE OF NORTH CAROLINA
DIVISION OF HIGHWAYS
POLK COUNTY

LOCATION: I-26 (FROM APPROX. MM 64 TO APPROX. MM 62.5)
TYPE OF WORK: GRADING, DRAINAGE AND PAVING

STATE	STATE PROJECT REFERENCE NO.	SHEET NO.	TOTAL SHEETS
N.C.	15614.1075010	1	
STATE PROJ. NO.	F.A. PROJ. NO.	DESCRIPTION	
15614.1075010	N/A	PE	
15614.1075010	N/A	RW & UTIL	
15614.1075010	N/A	CONST.	

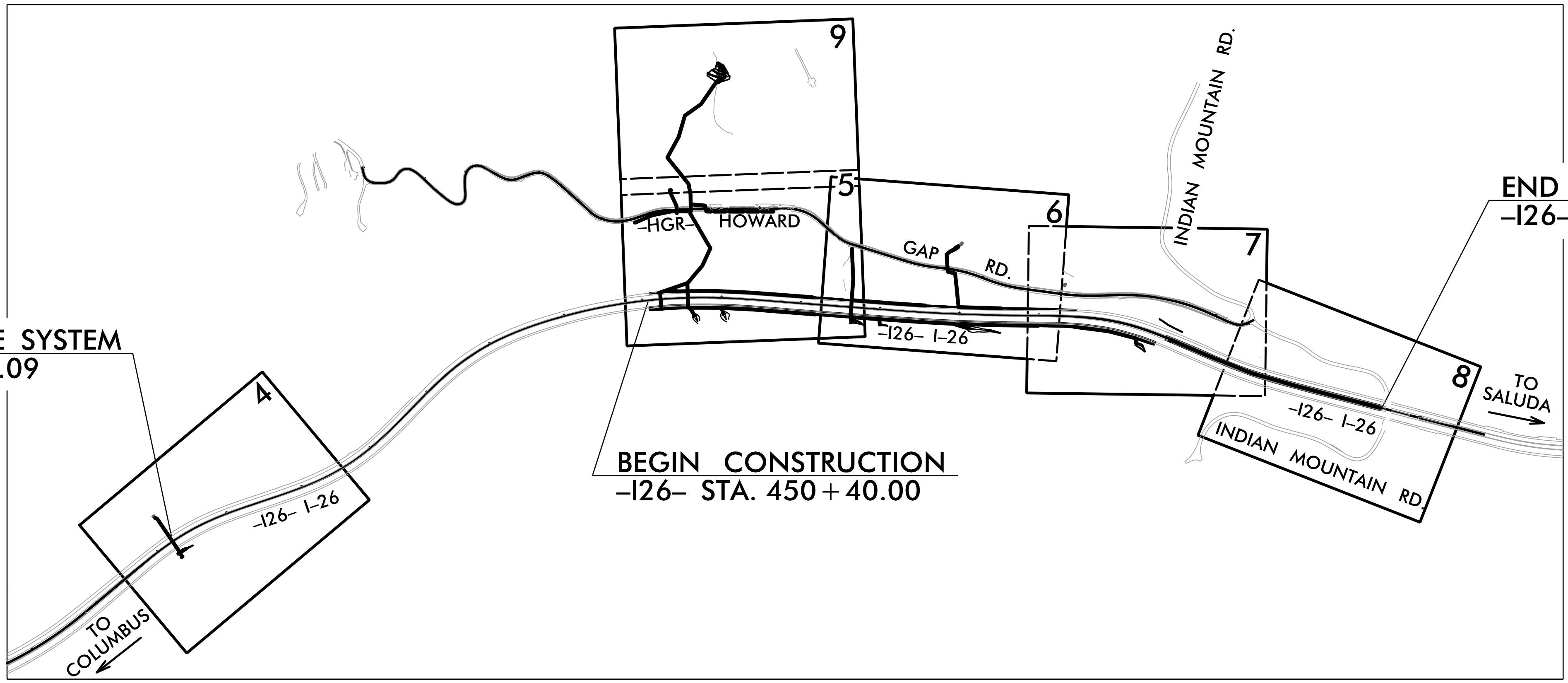
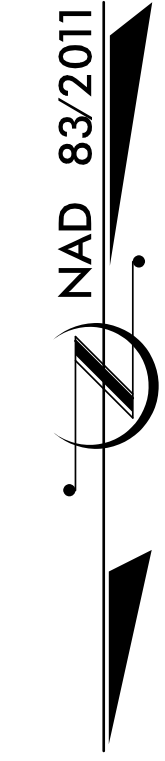

THIS IS A CONTROLLED ACCESS PROJECT WITH ACCESS LIMITED TO INTERCHANGES.

DOCUMENT NOT CONSIDERED FINAL UNLESS ALL SIGNATURES COMPLETED

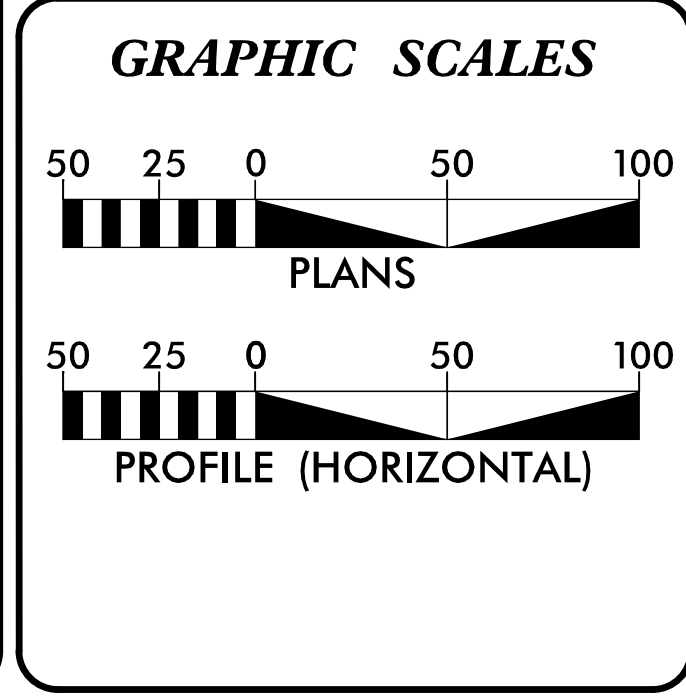

DESIGN DATA
ADT 2019 = 44,000
V = 70 MPH
FUNC CLASS = INTERSTATE
STATEWIDE TIER

PROJECT LENGTH
LENGTH ROADWAY PROJECT I-26 = 0.892 MILES
TOTAL LENGTH PROJECT I-26 = 0.892 MILES

NCDOT CONTACT: JEANETTE L. WHITE, PE

PLANS PREPARED BY: TGS ENGINEERS 201 W. MARION ST. SUITE 200 SHELBY, NC 28150 PH (704) 476-0003 CORP. LICENSE NO. C-0275	PLANS PREPARED FOR: NORTH CAROLINA DEPARTMENT OF TRANSPORTATION DIVISION 14 253 WEBSTER RD SYLVA, NC 28779
RIGHT OF WAY DATE: MAR. 01, 2021	JIMMY L. TERRY, PE PROJECT ENGINEER
LETTING DATE: OCT. 19, 2021	CLINTON B. PRUETT, PE PROJECT DESIGN ENGINEER

2018 STANDARD SPECIFICATIONS

HYDRAULICS ENGINEER

DocuSigned by:
Benjamin J. Henegar P.E.

ROADWAY DESIGN ENGINEER

DocuSigned by:
Clinton Pruet P.E.

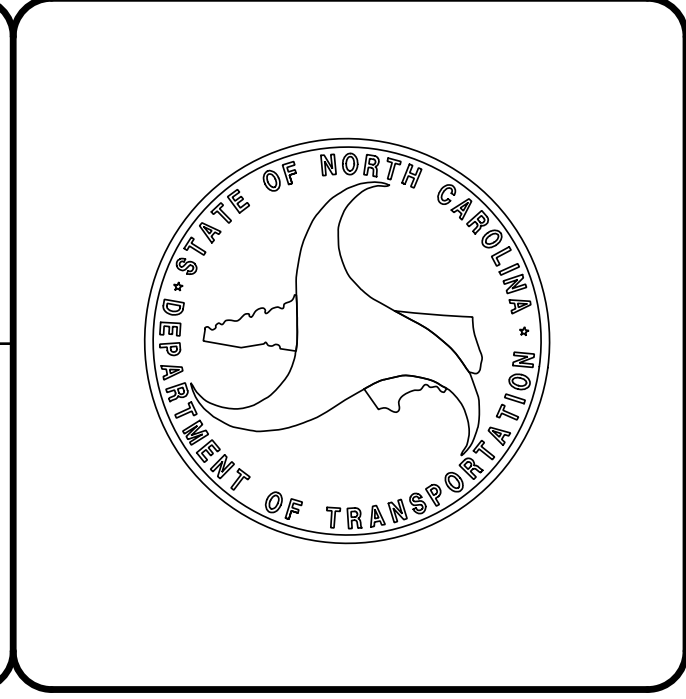

7/28/2021 X:\NG\001\I-26 Rehab\Roadway\Proj\I-26-Howard Gap_Rdy_tsh.dgn User:cpruet

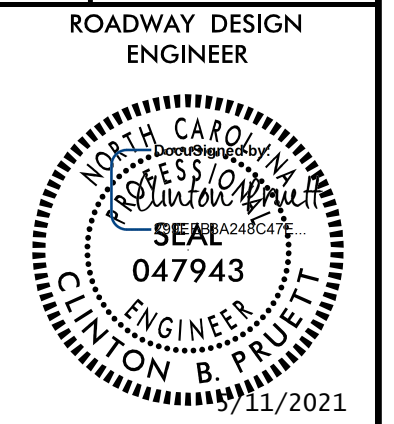

INDEX OF SHEETS

SHEET NUMBER	SHEET
1	TITLE SHEET
1A	INDEX OF SHEETS, GENERAL NOTES, AND STANDARD DRAWINGS
1B	CONVENTIONAL SYMBOLS
2A-1	PAVEMENT SCHEDULE AND TYPICAL SECTIONS
2C-1	SPECIAL DETAIL - GUARDRAIL INSTALLATION (W BEAM RAIL SECTION)
2C-2	SPECIAL DETAIL - 8' GUARDRAIL POST
2D-1 THRU 2D-3	DRAINAGE DETAIL - ENERGY DISSIPATOR JUNCTION BOX
2D-4 THRU 2D-7	DRAINAGE DETAIL - SPLITTER BOX
2D-8 THRU 2D-10	DRAINAGE DETAIL - SPECIAL DESIGN JUNCTION BOX
2D-11	DRAINAGE DETAIL - SPECIAL DESIGN PIPE CONNECTION
2D-12	DRAINAGE DETAIL - EXTRA DEPTH 2GI
2D-13	DRAINAGE DETAIL - VARIABLE WIDTH BASE DITCH
2D-14 THRU 2D-16	DRAINAGE DETAIL - ENERGY DISSIPATOR BASIN
2D-17 THRU 2D-18	DRAINAGE DETAIL - FOREBAY #1
2D-19 THRU 2D-20	DRAINAGE DETAIL - FOREBAY #2
2D-21 THRU 2D-23	DRAINAGE DETAIL - FOREBAY #3
2D-24 THRU 2D-26	DRAINAGE DETAIL - FOREBAY #4
2D-27 THRU 2D-29	DRAINAGE DETAIL - FOREBAY #5
2D-30	DRAINAGE DETAIL - PIPE PROFILE (0409 TO 0401)
2D-31	DRAINAGE DETAIL - PIPE PROFILE (0539 TO 0522)
2D-32	DRAINAGE DETAIL - PIPE PROFILE (0504 TO 0506)
2D-33 THRU 2D-34	DRAINAGE DETAIL - PIPE PROFILE (0901 TO 0525)
2D-35	DRAINAGE DETAIL - PIPE PROFILE (0542 TO 0607)
2D-36	DRAINAGE DETAIL - PIPE PROFILE (0614 TO 0622)
3B-1	EARTHWORK SUMMARY, PAVEMENT REMOVAL SUMMARY, SHOULDER BERM GUTTER SUMMARY, AND GUARDRAIL SUMMARY
3D-1 THRU 3D-7	DRAINAGE SUMMARIES
3G-1	GEOTECHNICAL SUMMARIES
3P-1	PARCEL INDEX SHEET
4 THRU 9	PLAN SHEETS
RW01THRU RW09	SURVEY CONTROL, EXISTING CENTERLINES, RIGHT OF WAY, EASEMENTS AND PROPERTY TIES
TMP-1 THRU TMP-8	TRANSPORTATION MANAGEMENT PLANS
PMP-1 THRU PMP-3	PAVEMENT MARKING PLANS
EC-1 THRU EC-15	EROSION CONTROL PLANS
RF-1	REFORESTATION DETAIL SHEET
UO-1 THRU UO-4	UTILITIES BY OTHERS PLANS
X-1A	CROSS-SECTION SUMMARY SHEET
X-1 THRU X-46	CROSS-SECTIONS

GENERAL NOTES

GENERAL NOTES:

2018 SPECIFICATIONS
EFFECTIVE: 01-16-2018
REVISED:

**GRADE LINE:
GRADING AND SURFACING OR RESURFACING AND WIDENING:**

THE GRADE LINES SHOWN DENOTE THE FINISHED ELEVATION OF THE PROPOSED SURFACING AT GRADE POINTS SHOWN ON THE TYPICAL SECTIONS. WHERE NO GRADE LINES ARE SHOWN, THE PROFILES SHOWN DENOTE THE TOP ELEVATION OF THE EXISTING PAVEMENT ALONG THE CENTER LINE OF SURVEY ON WHICH THE PROPOSED RESURFACING WILL BE PLACED. GRADE LINES MAY BE ADJUSTED BY THE ENGINEER IN ORDER TO SECURE A PROPER TIE-IN.

CLEARING:

CLEARING ON THIS PROJECT SHALL BE PERFORMED TO THE LIMITS ESTABLISHED BY METHOD II.

SUPERELEVATION:

ALL CURVES ON THIS PROJECT SHALL BE SUPERELEVATED IN ACCORDANCE WITH STD. NO. 225.05 USING THE RATE OF SUPERELEVATION AND RUNOFF SHOWN ON THE PLANS. SUPERELEVATION IS TO BE REVOLVED ABOUT THE GRADE POINTS SHOWN ON THE TYPICAL SECTIONS.

SHOULDER CONSTRUCTION:

ASPHALT, EARTH, AND CONCRETE SHOULDER CONSTRUCTION ON THE HIGH SIDE OF SUPERELEVATED CURVES SHALL BE IN ACCORDANCE WITH STD. NO. 560.02

SUBSURFACE DRAINS:

SUBSURFACE DRAINS SHALL BE CONSTRUCTED IN ACCORDANCE WITH STD. NO. 815.02 AT LOCATIONS DIRECTED BY THE ENGINEER.

GUARDRAIL:

THE GUARDRAIL LOCATIONS SHOWN ON THE PLANS MAY BE ADJUSTED DURING CONSTRUCTION AS DIRECTED BY THE ENGINEER. THE CONTRACTOR SHOULD CONSULT WITH THE ENGINEER PRIOR TO ORDERING GUARDRAIL MATERIAL.

TEMPORARY SHORING:

SHORING REQUIRED FOR THE MAINTENANCE OF TRAFFIC NOT SHOWN ON THE PLANS WILL BE PAID FOR AT THE CONTRACT PRICE FOR "TEMPORARY SHORING".

SUBSURFACE PLANS:

NO SUBSURFACE PLANS ARE AVAILABLE ON THIS PROJECT. THE CONTRACTOR SHOULD MAKE HIS OWN INVESTIGATION AS TO THE SUBSURFACE CONDITIONS.

UTILITIES:

UTILITY OWNERS ON THIS PROJECT ARE DUKE ENERGY TRANSMISSION, SPECTRUM, WINDSTREAM, TOWN OF TRYON, AND RIVERSTREET NETWORKS.

ANY RELOCATION OF EXISTING UTILITIES WILL BE ACCOMPLISHED BY OTHERS.

STANDARD DRAWINGS

2018 ROADWAY ENGLISH STANDARD DRAWINGS
EFF. 01-16-2018
REV.











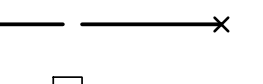
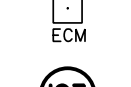

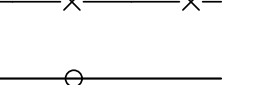
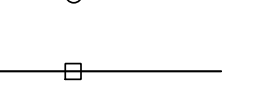
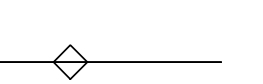
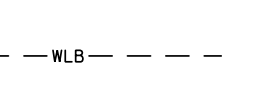
The following Roadway Standards as appear in "Roadway Standard Drawings" Highway Design Branch - N. C. Department of Transportation - Raleigh, N. C., Dated January, 2018 are applicable to this project and by reference hereby are considered a part of these plans:

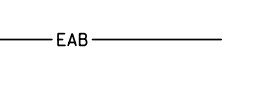
STD.NO.	TITLE
DIVISION 2 - EARTHWORK	
200.02	Method of Clearing - Method II
225.01	Guide for Grading Subgrade - Interstate and Freeway
225.05	Method of Obtaining Superelevation - Divided Highways
DIVISION 3 - PIPE CULVERTS	
300.01	Method of Pipe Installation
DIVISION 5 - SUBGRADE, BASES AND SHOULDERS	
560.02	Method of Shoulder Construction - High Side of Superelevated Curve - Method II
DIVISION 6 - ASPHALT BASES AND PAVEMENTS	
654.01	Pavement Repairs
665.01	Asphalt Shoulders - Milled Rumble Strips
DIVISION 8 - INCIDENTALS	
815.02	Subsurface Drain
838.01	Concrete Endwall for Single and Double Pipe Culverts - 15" thru 48" Pipe 90 Skew
838.11	Brick Endwall for Single and Double Pipe Culverts - 15" thru 48" Pipe 90 Skew
838.80	Precast Endwalls - 12" thru 72" Pipe 90 Skew
840.00	Concrete Base Pad for Drainage Structures
840.04	Concrete Open Throat Catch Basin - 12" thru 48" Pipe
840.05	Brick Open Throat Catch Basin - 12" thru 48" Pipe
840.17	Concrete Grated Drop Inlet Type 'A' - 12" thru 72" Pipe
840.18	Concrete Grated Drop Inlet Type 'B' - 12" thru 36" Pipe
840.20	Frames and Wide Slot Flat Grates
840.22	Frames and Wide Slot Sag Grates
840.25	Anchorage for Frames - Brick or Concrete or Precast
840.26	Brick Grated Drop Inlet Type 'A' - 12" thru 72" Pipe
840.27	Brick Grated Drop Inlet Type 'B' - 12" thru 36" Pipe
840.31	Concrete Junction Box - 12" thru 66" Pipe
840.32	Brick Junction Box - 12" thru 66" Pipe
840.34	Traffic Bearing Junction Box - for Use with Pipes 42" and Under
840.35	Traffic Bearing Grated Drop Inlet - for Cast Iron Double Frame and Grates
840.45	Precast Drainage Structure
840.46	Traffic Bearing Precast Drainage Structure
840.54	Manhole Frame and Cover
840.66	Drainage Structure Steps
840.71	Concrete and Brick Pipe Plug
846.01	Concrete Curb, Gutter and Curb & Gutter
846.04	Drop Inlet Installation in Shoulder Berm Gutter
850.01	Concrete Paved Ditches
850.11	Guide for Berm Drainage Outlet - 24" and 30" Pipe
862.01	Guardrail Placement
862.02	Guardrail Installation (Special Detail for Sheet 6 of 8)
862.04	Anchoring End of Guardrail - B-77 and B-83 Anchor Units
866.02	Woven Wire Fence - with Wood Post
876.01	Rip Rap in Channels
876.02	Guide for Rip Rap at Pipe Outlets

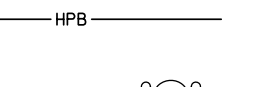

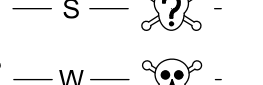
STATE OF NORTH CAROLINA, DIVISION OF HIGHWAYS

CONVENTIONAL PLAN SHEET SYMBOLS



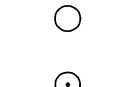
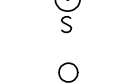
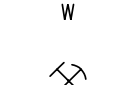
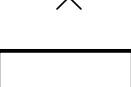
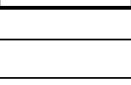
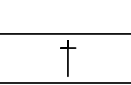
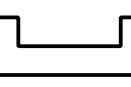
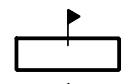
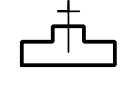
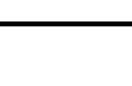

BOUNDARIES AND PROPERTY:

State Line	_____
County Line	_____
Township Line	_____
City Line	_____
Reservation Line	_____
Property Line	_____
Existing Iron Pin	
Computed Property Corner	
Property Monument	
Parcel/Sequence Number	
Existing Fence Line	
Proposed Woven Wire Fence	
Proposed Chain Link Fence	
Proposed Barbed Wire Fence	
Existing Wetland Boundary	
Proposed Wetland Boundary	
Existing Endangered Animal Boundary	
Existing Endangered Plant Boundary	
Existing Historic Property Boundary	
Known Contamination Area: Soil	
Potential Contamination Area: Soil	
Known Contamination Area: Water	
Potential Contamination Area: Water	
Contaminated Site: Known or Potential	

BUILDINGS AND OTHER CULTURE:

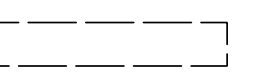
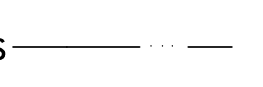
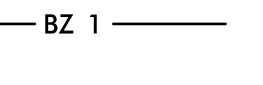
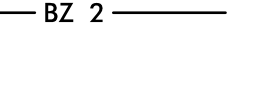
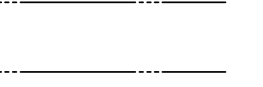
Gas Pump Vent or U/G Tank Cap	
Sign	
Well	
Small Mine	
Foundation	
Area Outline	
Cemetery	
Building	
School	
Church	
Dam	

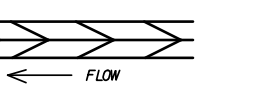
HYDROLOGY:

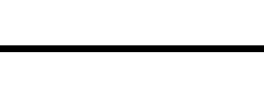











Stream or Body of Water	_____
Hydro, Pool or Reservoir	
Jurisdictional Stream	
Buffer Zone 1	
Buffer Zone 2	
Flow Arrow	
Disappearing Stream	
Spring	
Wetland	
Proposed Lateral, Tail, Head Ditch	
False Sump	

RAILROADS:

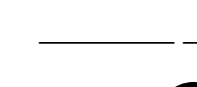

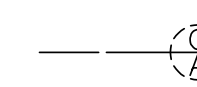

Standard Gauge	_____
RR Signal Milepost	
Switch	
RR Abandoned	_____
RR Dismantled	_____

Note: Not to Scale *S.U.E. = *Subsurface Utility Engineering*

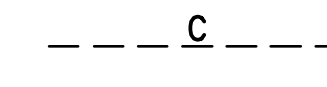
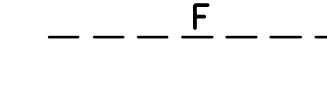

RIGHT OF WAY & PROJECT CONTROL:

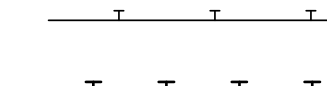
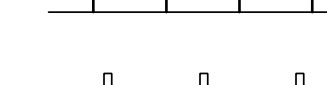
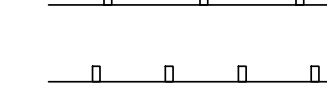
Secondary Horiz and Vert Control Point	
Primary Horiz Control Point	
Primary Horiz and Vert Control Point	
Exist Permanent Easement Pin and Cap	
New Permanent Easement Pin and Cap	
Vertical Benchmark	
Existing Right of Way Marker	
Existing Right of Way Line	_____
New Right of Way Line	
New Right of Way Line with Pin and Cap	
New Right of Way Line with Concrete or Granite RW Marker	
New Control of Access Line with Concrete CA Marker	
Existing Control of Access	
New Control of Access	
Existing Easement Line	_____
New Temporary Construction Easement	_____
New Temporary Drainage Easement	_____
New Permanent Drainage Easement	_____
New Permanent Drainage / Utility Easement	_____
New Permanent Utility Easement	_____
New Temporary Utility Easement	_____
New Aerial Utility Easement	_____

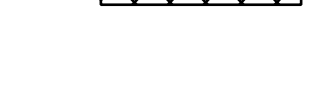
ROADS AND RELATED FEATURES:

Existing Edge of Pavement	_____
Existing Curb	_____
Proposed Slope Stakes Cut	
Proposed Slope Stakes Fill	
Proposed Curb Ramp	
Existing Metal Guardrail	
Proposed Guardrail	
Existing Cable Guiderail	
Proposed Cable Guiderail	
Equality Symbol	
Pavement Removal	

VEGETATION:







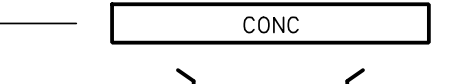
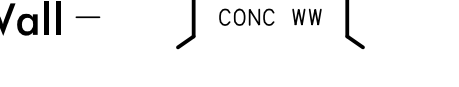
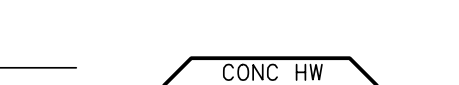
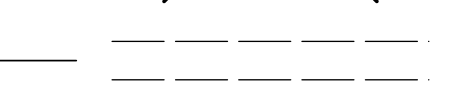
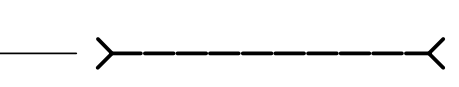
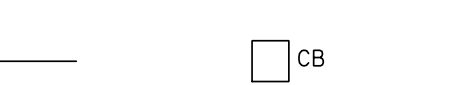
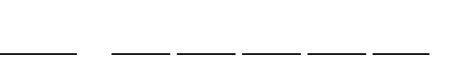

Single Tree	
Single Shrub	

Hedge	
Woods Line	
Orchard	
Vineyard	



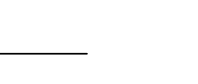

EXISTING STRUCTURES:

MAJOR:	
Bridge, Tunnel or Box Culvert	
Bridge Wing Wall, Head Wall and End Wall	
MINOR:	
Head and End Wall	
Pipe Culvert	
Footbridge	
Drainage Box: Catch Basin, DI or JB	
Paved Ditch Gutter	_____
Storm Sewer Manhole	
Storm Sewer	_____



UTILITIES:

POWER:	
Existing Power Pole	
Proposed Power Pole	
Existing Joint Use Pole	
Proposed Joint Use Pole	
Power Manhole	
Power Line Tower	
Power Transformer	
U/G Power Cable Hand Hole	_____
H-Frame Pole	
U/G Power Line LOS B (S.U.E.*)	_____
U/G Power Line LOS C (S.U.E.*)	_____
U/G Power Line LOS D (S.U.E.*)	_____

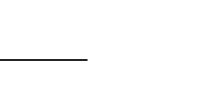

TELEPHONE:

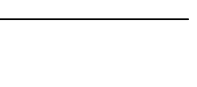
Existing Telephone Pole	
Proposed Telephone Pole	
Telephone Manhole	
Telephone Pedestal	
Telephone Cell Tower	
U/G Telephone Cable Hand Hole	_____
U/G Telephone Cable LOS B (S.U.E.*)	_____
U/G Telephone Cable LOS C (S.U.E.*)	_____
U/G Telephone Cable LOS D (S.U.E.*)	_____
U/G Telephone Conduit LOS B (S.U.E.*)	_____
U/G Telephone Conduit LOS C (S.U.E.*)	_____
U/G Telephone Conduit LOS D (S.U.E.*)	_____
U/G Fiber Optics Cable LOS B (S.U.E.*)	_____
U/G Fiber Optics Cable LOS C (S.U.E.*)	_____
U/G Fiber Optics Cable LOS D (S.U.E.*)	_____

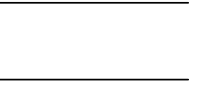
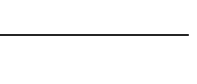

WATER:

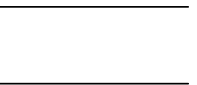
Water Manhole	
Water Meter	
Water Valve	
Water Hydrant	
U/G Water Line LOS B (S.U.E.*)	_____
U/G Water Line LOS C (S.U.E.*)	_____
U/G Water Line LOS D (S.U.E.*)	_____
Above Ground Water Line	

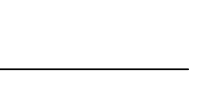
TV:

TV Pedestal	
TV Tower	
U/G TV Cable Hand Hole	
U/G TV Cable LOS B (S.U.E.*)	_____
U/G TV Cable LOS C (S.U.E.*)	_____
U/G TV Cable LOS D (S.U.E.*)	_____
U/G Fiber Optic Cable LOS B (S.U.E.*)	_____
U/G Fiber Optic Cable LOS C (S.U.E.*)	_____
U/G Fiber Optic Cable LOS D (S.U.E.*)	_____

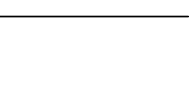

GAS:

Gas Valve	
Gas Meter	
U/G Gas Line LOS B (S.U.E.*)	_____
U/G Gas Line LOS C (S.U.E.*)	_____
U/G Gas Line LOS D (S.U.E.*)	_____
Above Ground Gas Line	

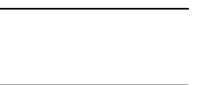
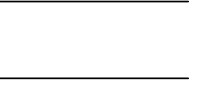
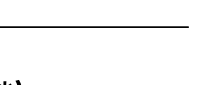
SANITARY SEWER:

Sanitary Sewer Manhole	
Sanitary Sewer Cleanout	
U/G Sanitary Sewer Line	_____
Above Ground Sanitary Sewer	
SS Forced Main Line LOS B (S.U.E.*)	_____
SS Forced Main Line LOS C (S.U.E.*)	_____
SS Forced Main Line LOS D (S.U.E.*)	_____

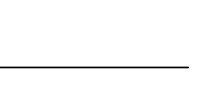
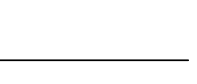
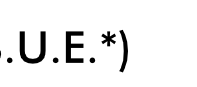
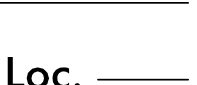
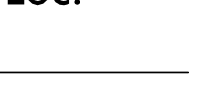
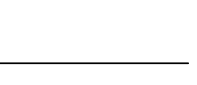
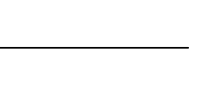
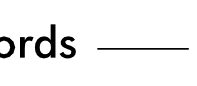
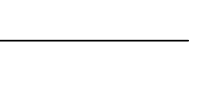
MISCELLANEOUS:

Utility Pole	
Utility Pole with Base	
Utility Located Object	
Utility Traffic Signal Box	
Utility Unknown U/G Line LOS B (S.U.E.*)	_____
U/G Tank; Water, Gas, Oil	
Underground Storage Tank, Approx. Loc.	
A/G Tank; Water, Gas, Oil	
Geoenvironmental Boring	
U/G Test Hole LOS A (S.U.E.*)	
Abandoned According to Utility Records	
End of Information	

8/17/19

PAVEMENT SCHEDULE

C1	PROP. APPROX. 3" ASPHALT CONCRETE SURFACE COURSE, TYPE S9.5C, AT AN AVERAGE RATE OF 168 LBS. PER SQ. YD. IN EACH OF TWO LAYERS.
C2	PROP. VAR. DEPTH ASPHALT CONCRETE SURFACE COURSE, TYPE S9.5C, AT AN AVERAGE RATE OF 112 LBS. PER SQ. YD. PER 1" DEPTH. TO BE PLACED IN LAYERS NOT TO EXCEED 2" IN DEPTH.
D1	PROP. APPROX. 4" ASPHALT CONCRETE INTERMEDIATE COURSE, TYPE I19.0C, AT AN AVERAGE RATE OF 456 LBS. PER SQ. YD.
D2	PROP. VAR. DEPTH ASPHALT CONCRETE INTERMEDIATE COURSE, TYPE I19.0C, AT AN AVERAGE RATE OF 114 LBS. PER SQ. YD. PER 1" DEPTH. TO BE PLACED IN LAYERS NOT LESS THAN 2 1/2" IN DEPTH OR GREATER THAN 4" IN DEPTH.
E1	PROP. APPROX. 8" ASPHALT CONCRETE BASE COURSE, TYPE B25.0C, AT AN AVERAGE RATE OF 456 LBS. PER SQ. YD. IN EACH OF TWO LAYERS.
E2	PROP. VAR. DEPTH ASPHALT CONCRETE BASE COURSE, TYPE B25.0C, AT AN AVERAGE RATE OF 114 LBS. PER SQ. YD. PER 1" DEPTH. TO BE PLACED IN LAYERS NOT LESS THAN 3" IN DEPTH OR GREATER THAN 5 1/2" IN DEPTH.
R1	4" CONCRETE DITCH.
R2	SHOULDER BERM GUTTER
T	EARTH MATERIAL.
U	EXISTING PAVEMENT.
V	MILLING EXISTING PAVEMENT (0 TO 3").
W	WEDGING EXISTING PAVEMENT, SEE WEDGING DETAILS.

PAVEMENT EDGE SLOPES ARE 1:1 UNLESS SHOWN OTHERWISE.

REVISIONS

3/26/2021
X:\NCDOT\K1-26 Howard Gap Rd Rehab\Roadway\Proj\1-26-Howard Gap_Rdy_typ.dgn
Jstancu

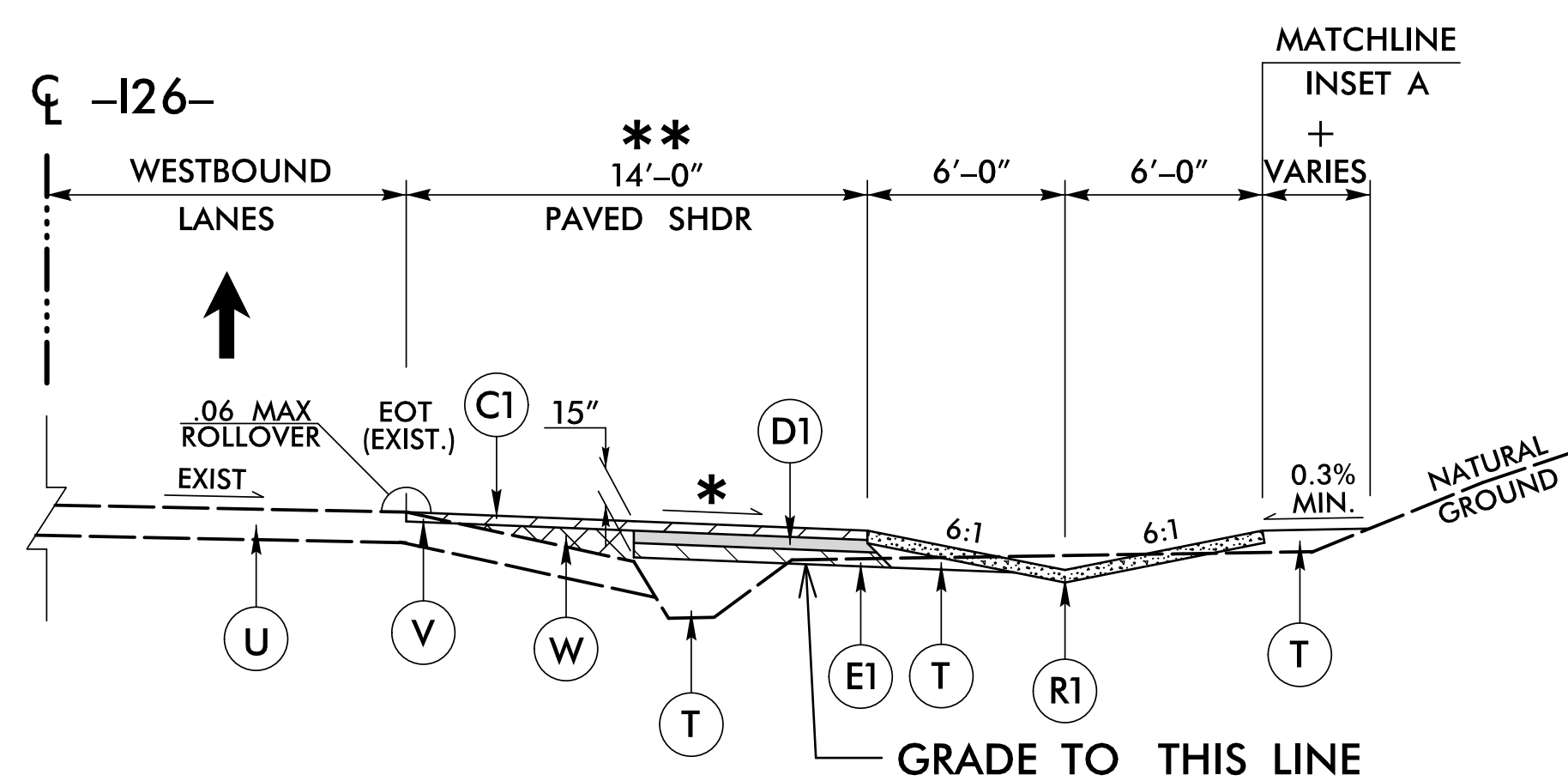

TYPICAL SECTION NO. 1

USE TYPICAL SECTION NO. 1
 -126- STA. 450+90.00 TO -126- STA. 482+15.00, RT
 NOTE: TRANSITION BETWEEN EXISTING AND TYP. SECT. NO. 1 AS FOLLOWS:
 -126- STA. 450+40.00 TO -126- STA. 450+90.00, RT
 -126- STA. 482+15.00 TO -126- STA. 482+65.00, RT

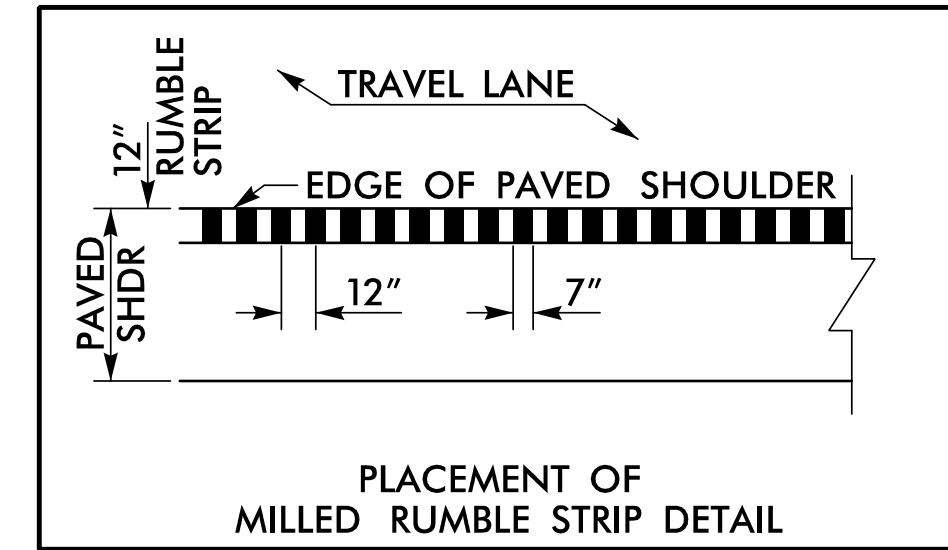

** USE DETAIL AS FOLLOWS:

-126- STA. 450+40.00 TO -126- STA. 482+65.00, RT
 -126- STA. 483+18.56 TO -126- STA. 497+50.00, CL (LT & RT)

* REFER TO STD. 560.02, SHEET 2 OF 2 IN THE 2018 ROADWAY STANDARD DRAWINGS FOR SUPERELEVATION RATES ON PAVED AND TURF SHOULDERS.

+ TIE SLOPE INTO EXISTING GROUND AND GRADE TO DRAIN INTO CONCRETE DITCH. SEE XSC FOR ADDITIONAL INFORMATION ON SLOPE VARIATIONS BEYOND MINIMUM.

PROJECT REFERENCE NO. 15614.1075010	SHEET NO. 2A-1
RW SHEET NO.	
ROADWAY DESIGN & PAVEMENT DESIGN ENGINEER	
DOCUMENT NOT CONSIDERED FINAL UNLESS ALL SIGNATURES COMPLETED	
TGS ENGINEERS 804-C N. LAFAYETTE ST SHELBY, NC 28150 PH (704) 476-0003 CORP. LICENSE NO.: C-0275	

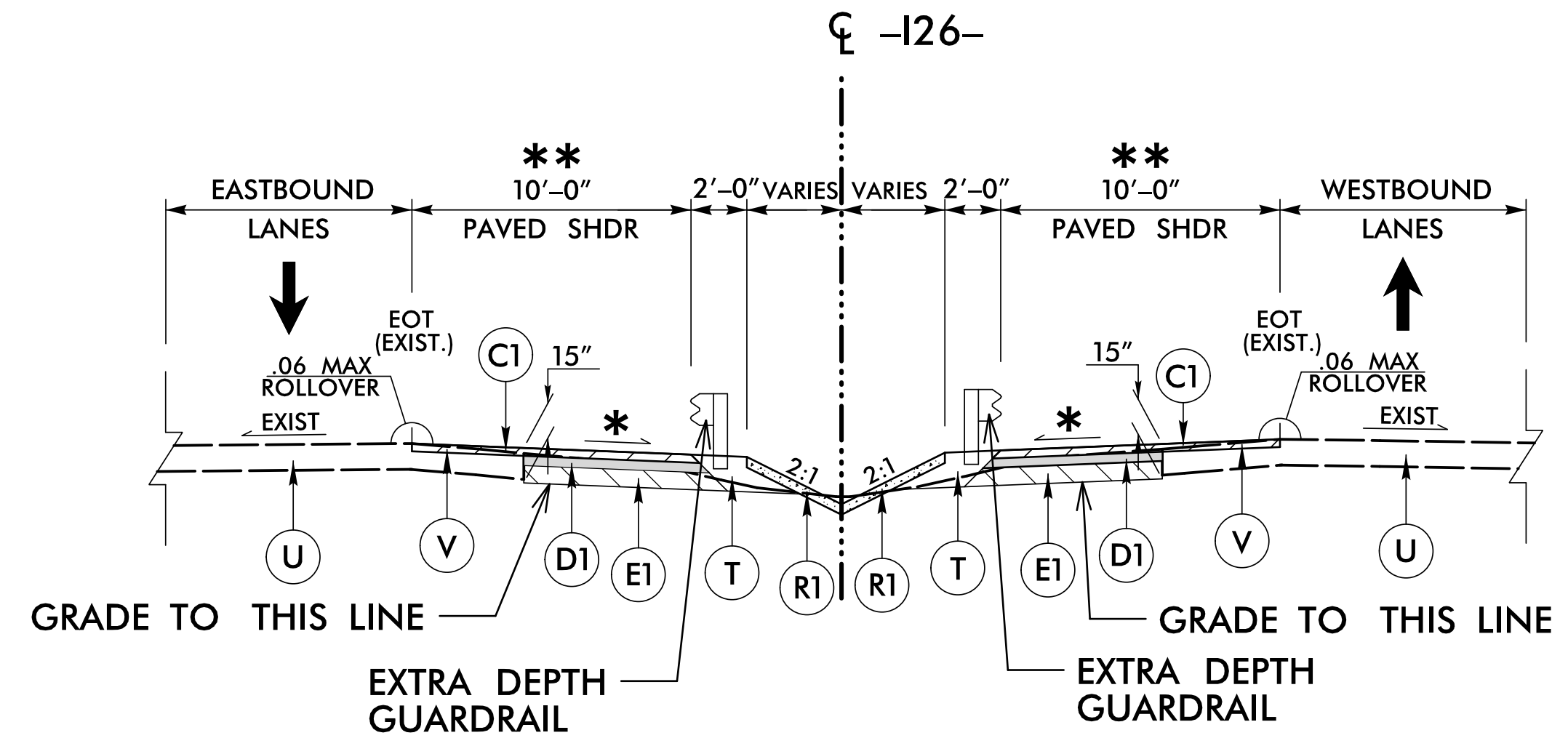

TYPICAL SECTION NO. 3

USE TYPICAL SECTION NO. 3
 -126- STA. 483+95.00 TO -126- STA. 497+50.00, LT
 -126- STA. 484+66.44 TO -126- STA. 497+50.00, RT
 NOTE: TRANSITION BETWEEN EXISTING AND TYP. SECT. NO. 3 AS FOLLOWS:
 -126- STA. 483+18.56 TO -126- STA. 483+95.00, LT
 -126- STA. 483+18.56 TO -126- STA. 484+66.44, RT

NOTE: PAVE FULL WIDTH MEDIAN:
 -126- STA. 483+18.56 TO -126- STA. 483+95.00

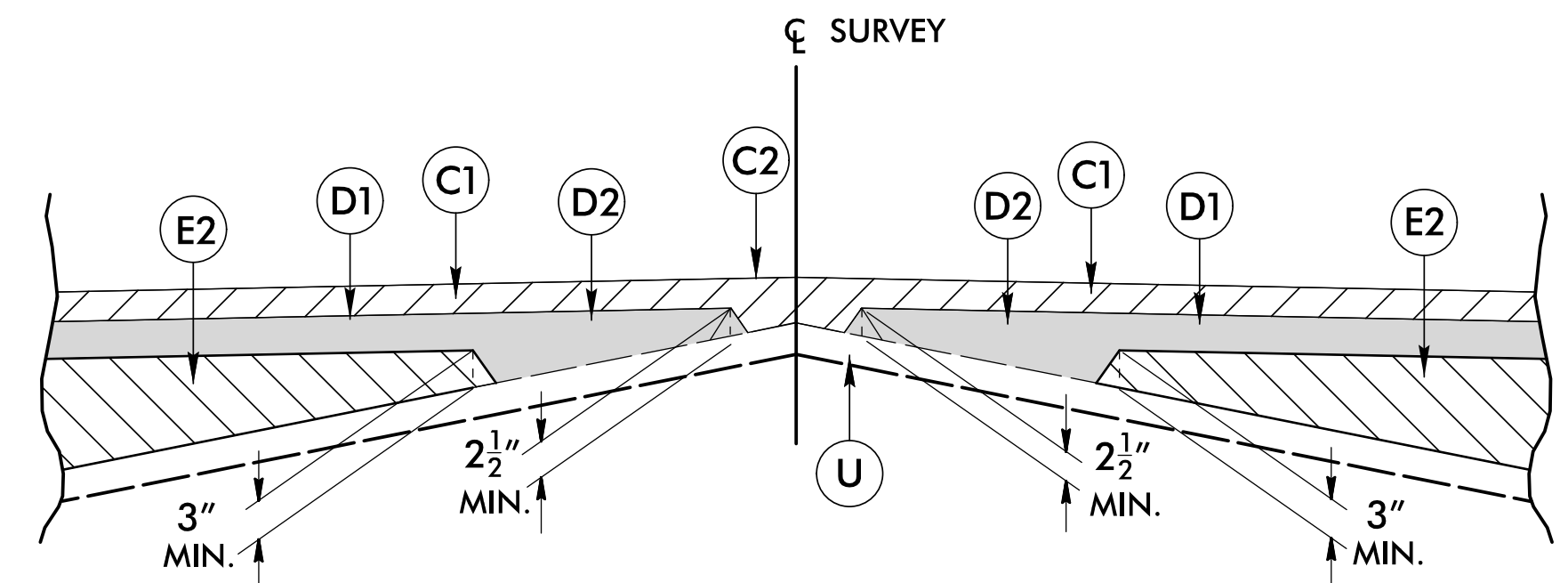

Detail Showing Method of Wedging

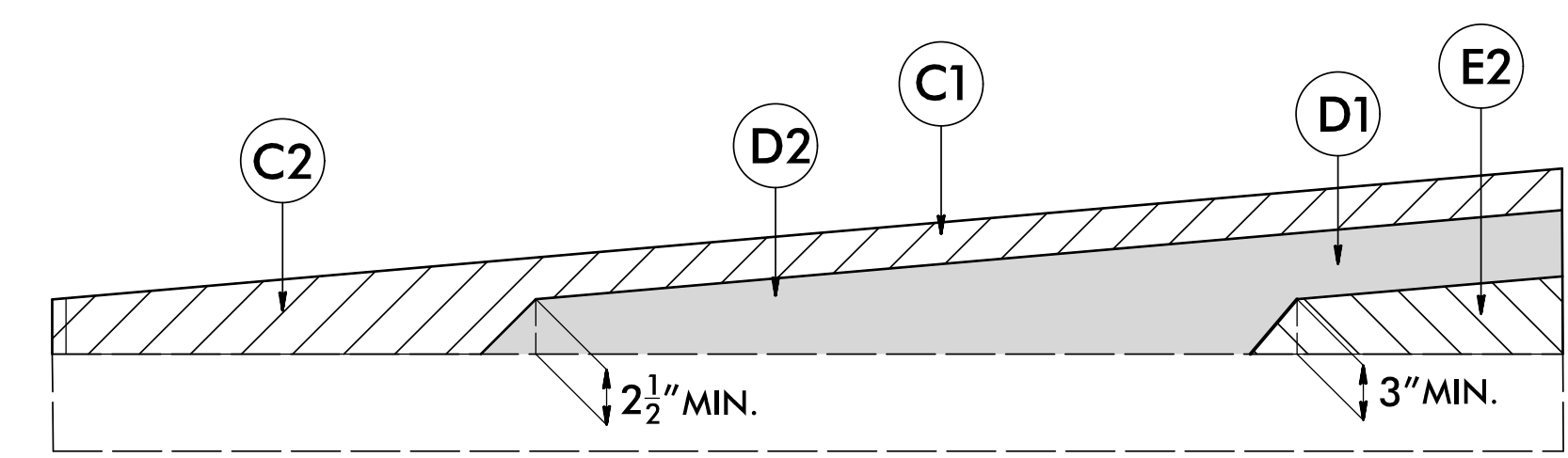

Wedging Detail For Resurfacing

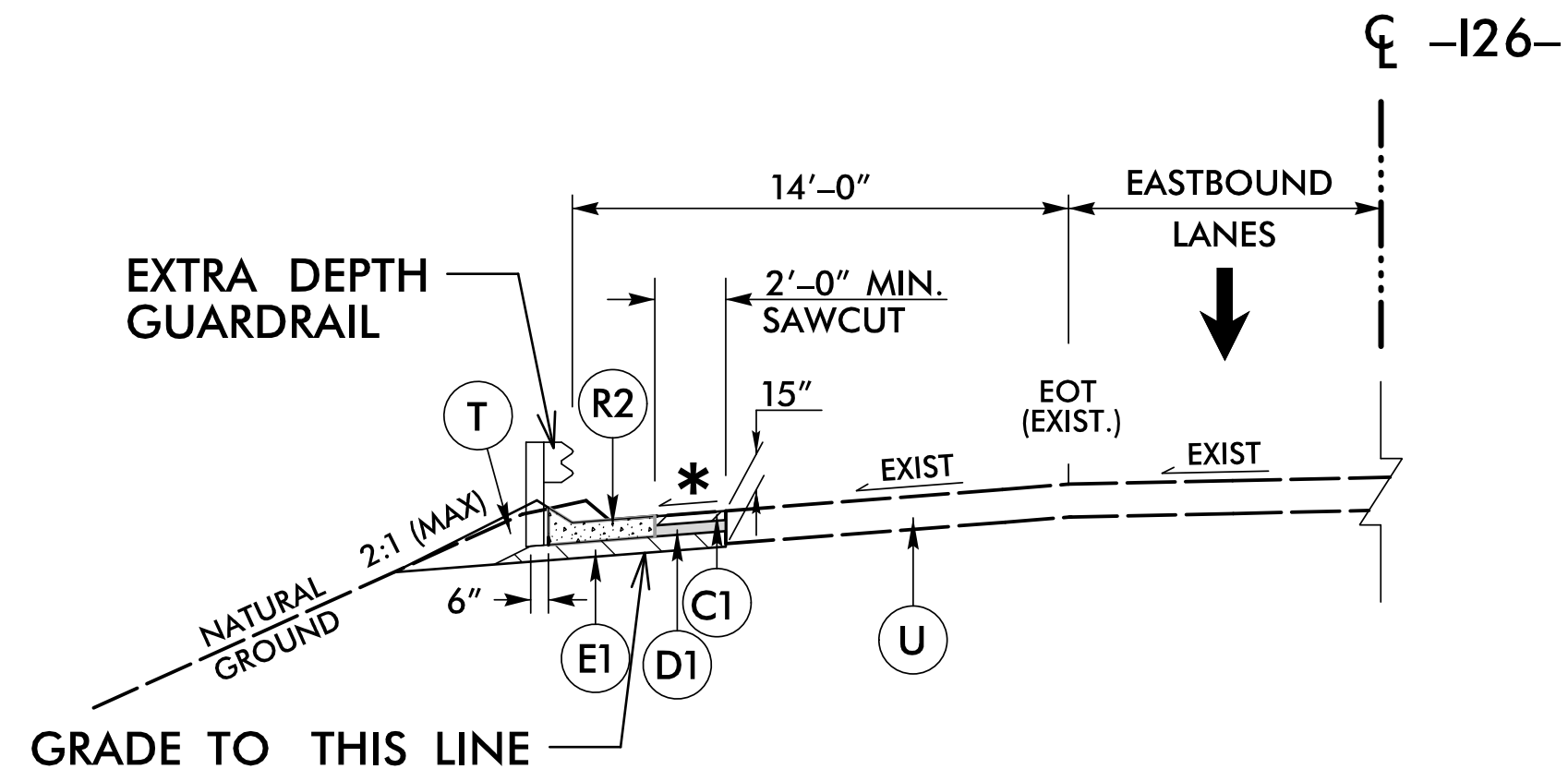

TYPICAL SECTION NO. 2

USE TYPICAL SECTION NO. 2
 -126- STA. 451+00.00 TO -126- STA. 476+00.00, LT
 NOTE: TRANSITION BETWEEN EXISTING AND TYP. SECT. NO. 2 AS FOLLOWS:
 -126- STA. 450+50.00 TO -126- STA. 451+00.00, LT
 -126- STA. 476+00.00 TO -126- STA. 477+31.25, LT

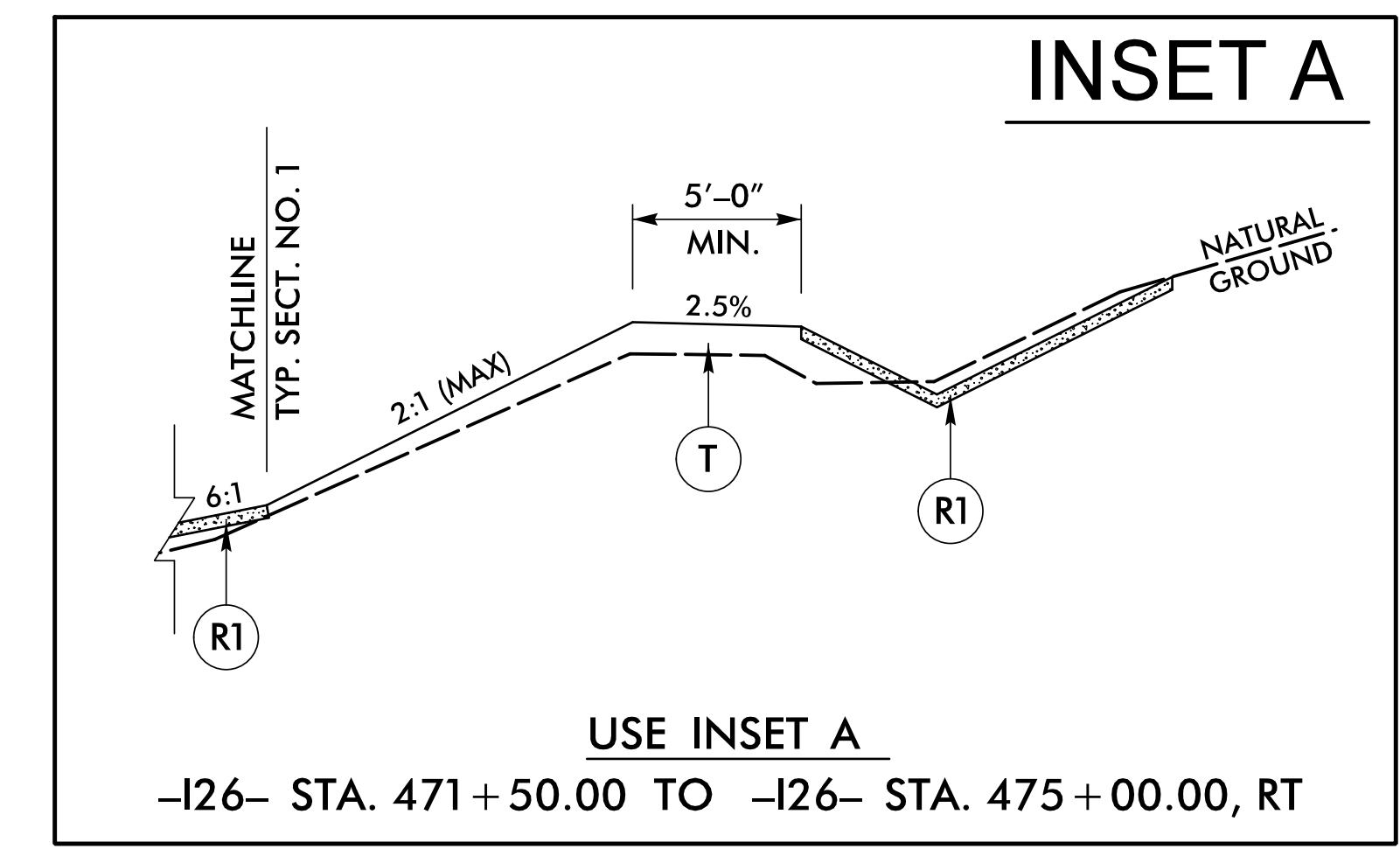

USE INSET A
 -126- STA. 471+50.00 TO -126- STA. 475+00.00, RT

STATE OF NORTH CAROLINA
DEPT. OF TRANSPORTATION
DIVISION OF HIGHWAYS
RALEIGH, N.C.

ROADWAY DETAIL DRAWING FOR
GUARDRAIL INSTALLATION

SHEET 6 OF 8
862D02

STATE OF NORTH CAROLINA
DEPT. OF TRANSPORTATION
DIVISION OF HIGHWAYS
RALEIGH, N.C.

ROADWAY DETAIL DRAWING FOR
GUARDRAIL INSTALLATION

SHEET 6 OF 8
862D02

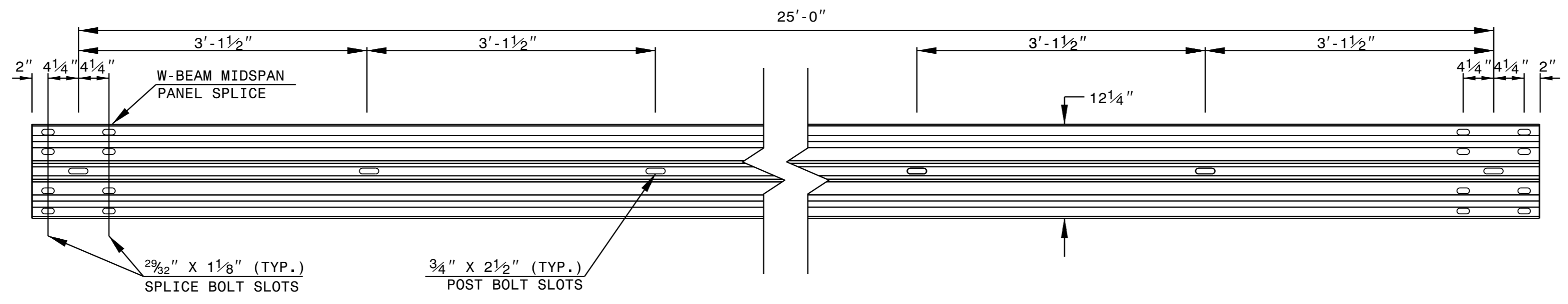

STANDARD W-BEAM GUARDRAIL

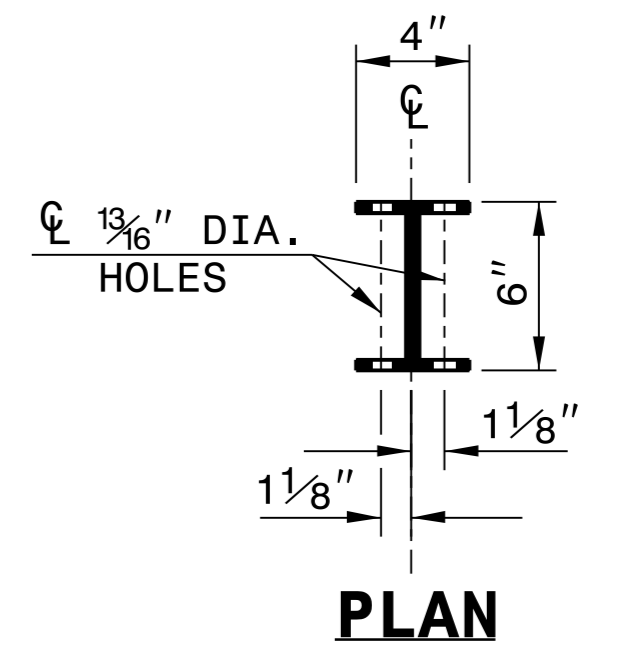

PLAN

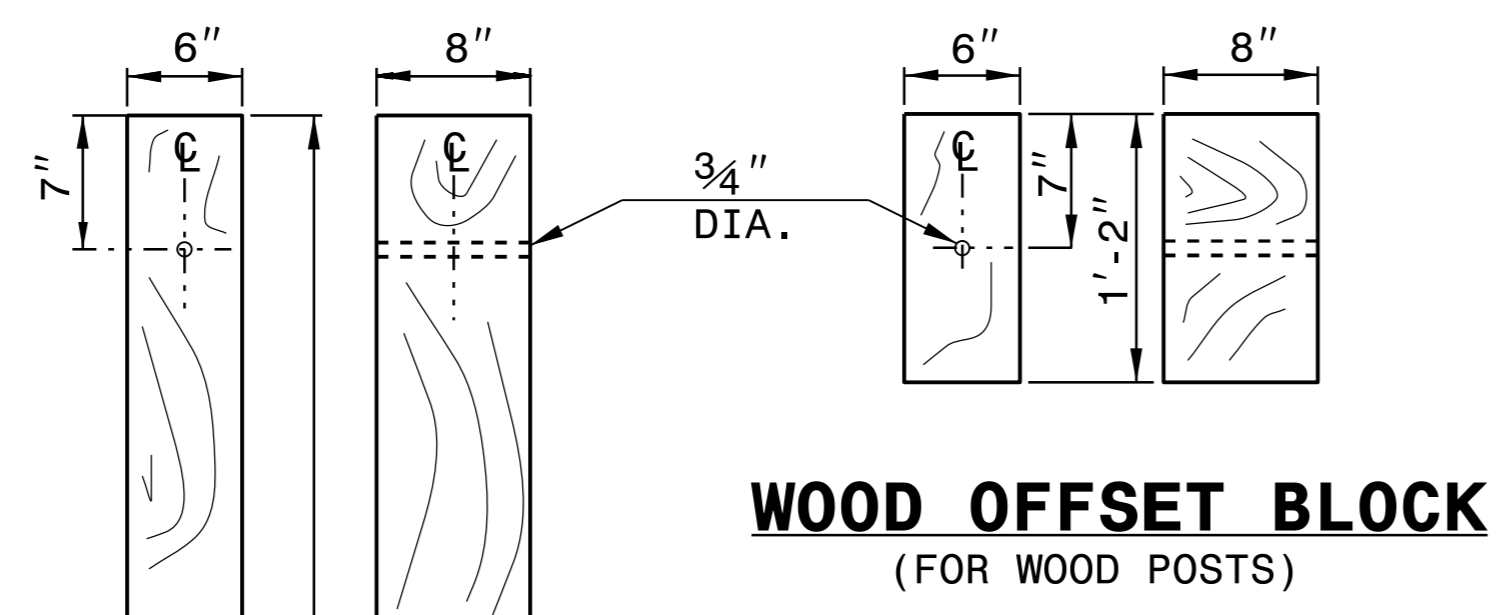

**WOOD OFFSET BLOCK
(FOR WOOD POSTS)**

**STANDARD
LINE POST**

**SHORT WOOD
BREAKAWAY POST**

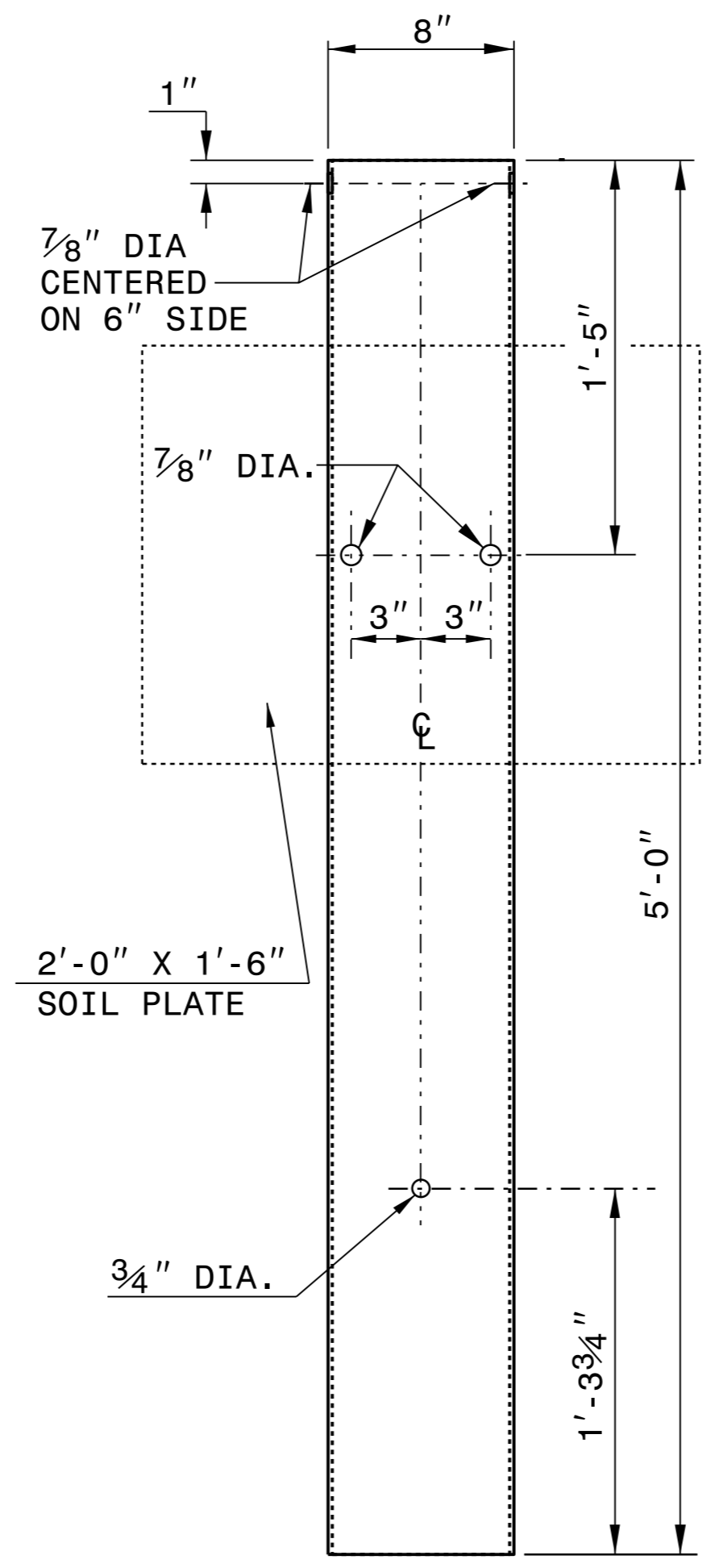

**STEEL TUBE
TS 6"x8"x0.1875"**

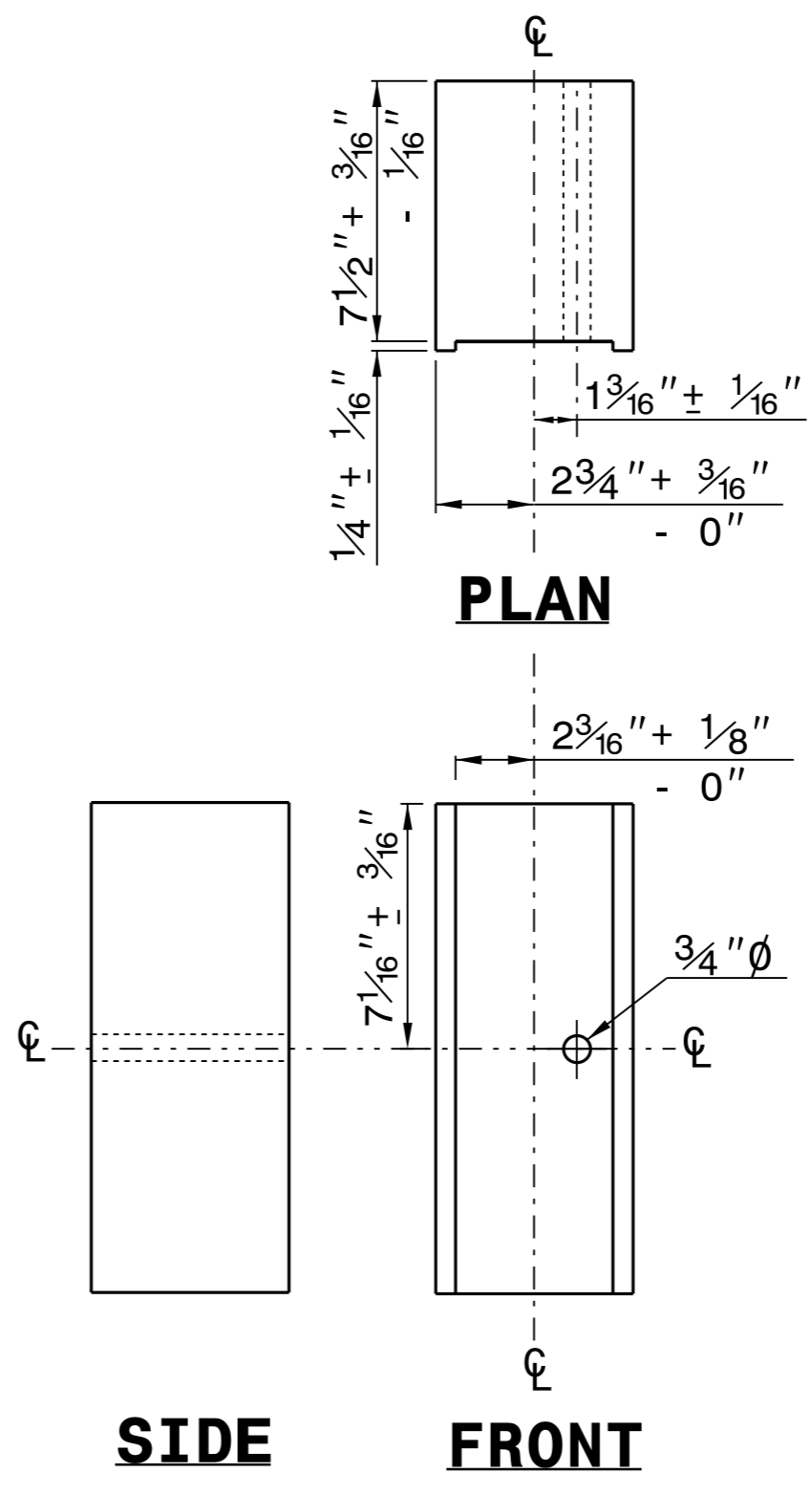

PLAN

SIDE

FRONT

**ROUTED
OFFSET BLOCK**

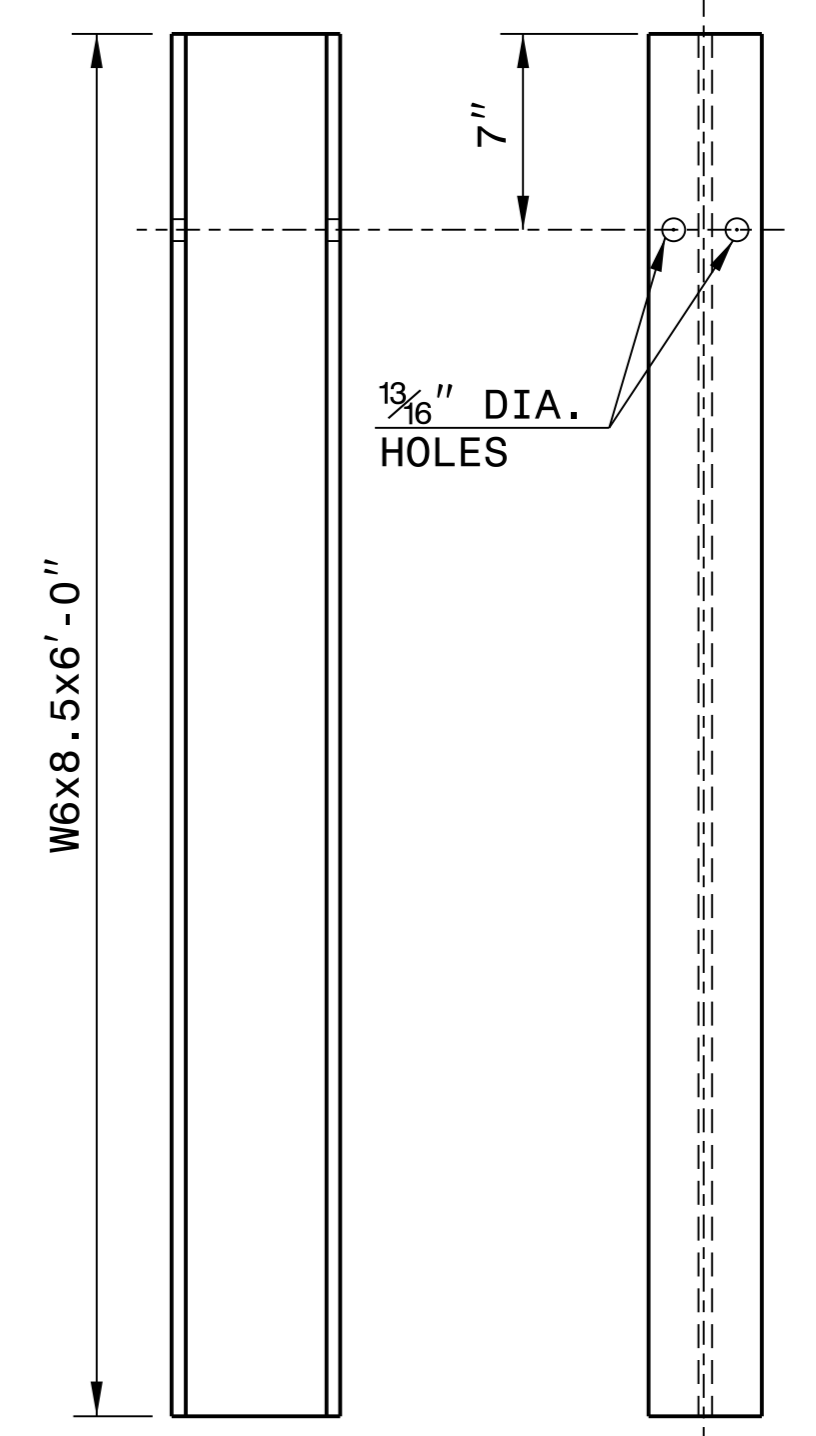

SIDE

FRONT

"W6" STEEL POST

SYSTEM PARTS

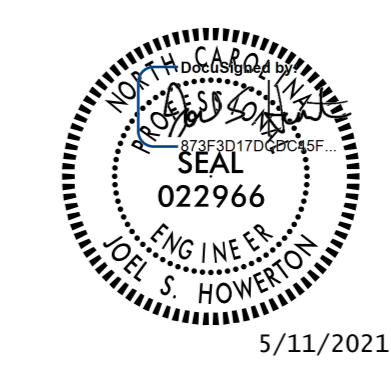

5/11/2021

**CONTRACTS STANDARDS
AND DEVELOPMENT UNIT**
Office 919-707-6950 FAX 919-250-4119

SEE TITLE BLOCK

ORIGINAL BY: J. HOWERTON	DATE: 3-7-2018
MODIFIED BY:	DATE:
CHECKED BY:	DATE:
FILE SPEC.:	

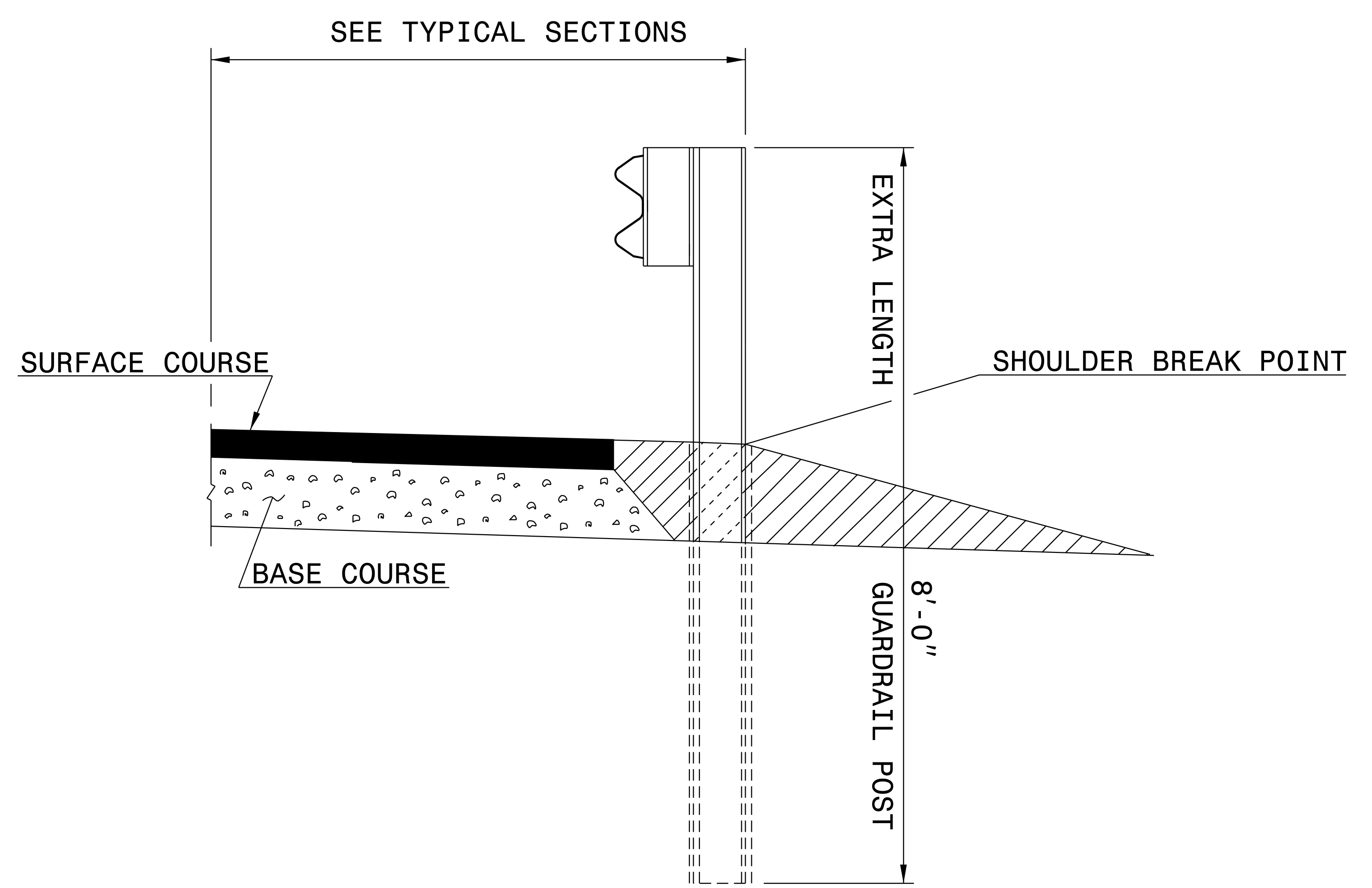

09-MAY-2018 14:21
S:\Contracts\Projects\Special Details\hoverton\7'postguardrail.dgn
hoverton AT CSD-232595

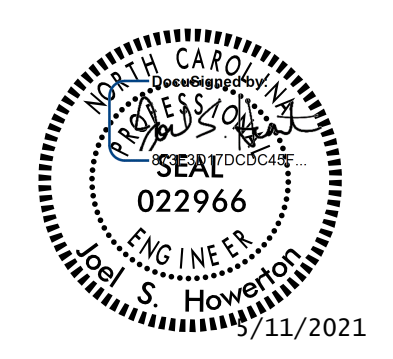

DOCUMENT NOT CONSIDERED FINAL
UNLESS ALL SIGNATURES COMPLETED

CONTRACT STANDARDS AND DEVELOPMENT UNIT	
Office 919-707-6950	FAX 919-250-4119
8' GUARDRAIL POST	
ORIGINAL BY: L. Robinson	DATE: 1995
MODIFIED BY: L. Robinson	DATE: Feb, 1996
CHECKED BY:	DATE:
FILE SPEC.: s:7'postguardrail.dgn	

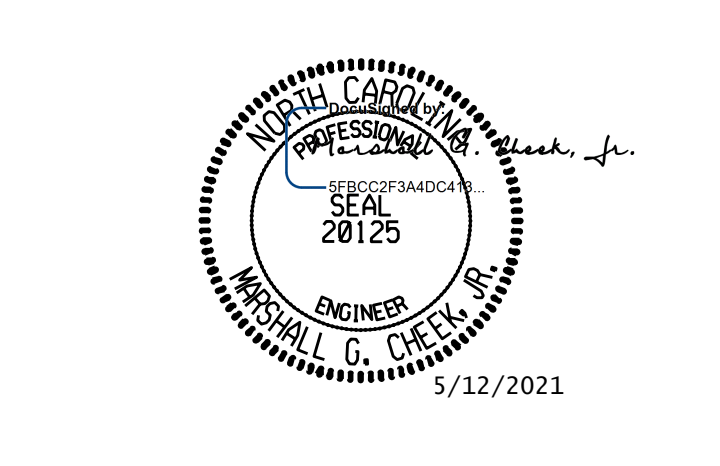

DOCUMENT NOT CONSIDERED FINAL
UNLESS ALL SIGNATURES COMPLETED

IGS ENGINEERS
706 HILLSBOROUGH STREET
SUITE 200
RALEIGH, NC 27603
PH (919) 773-8887
CORP. LICENSE NO.: C-0275

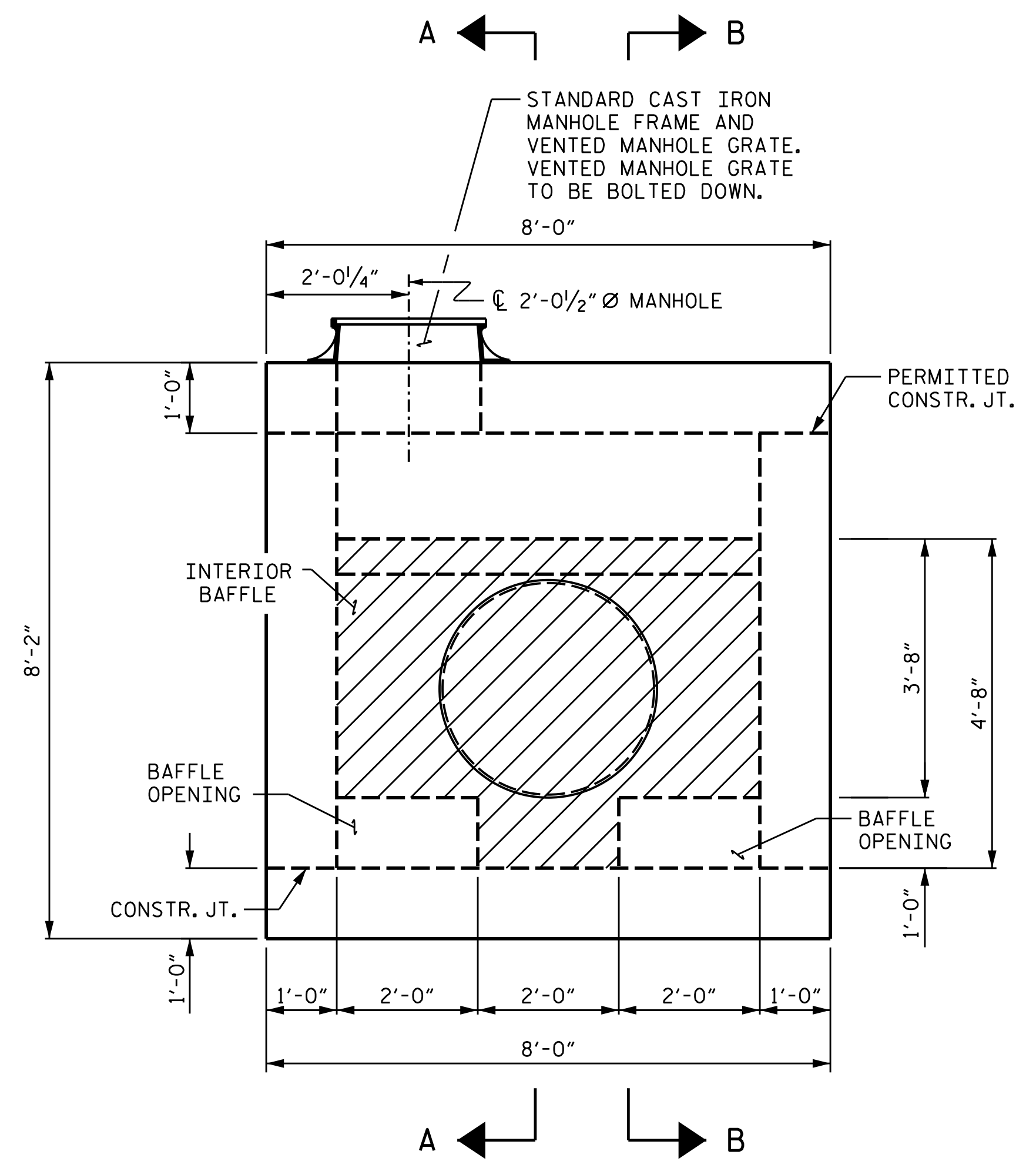

END ELEVATION
FOR SECTION A-A & B-B, SEE SHEET 2 OF 3.

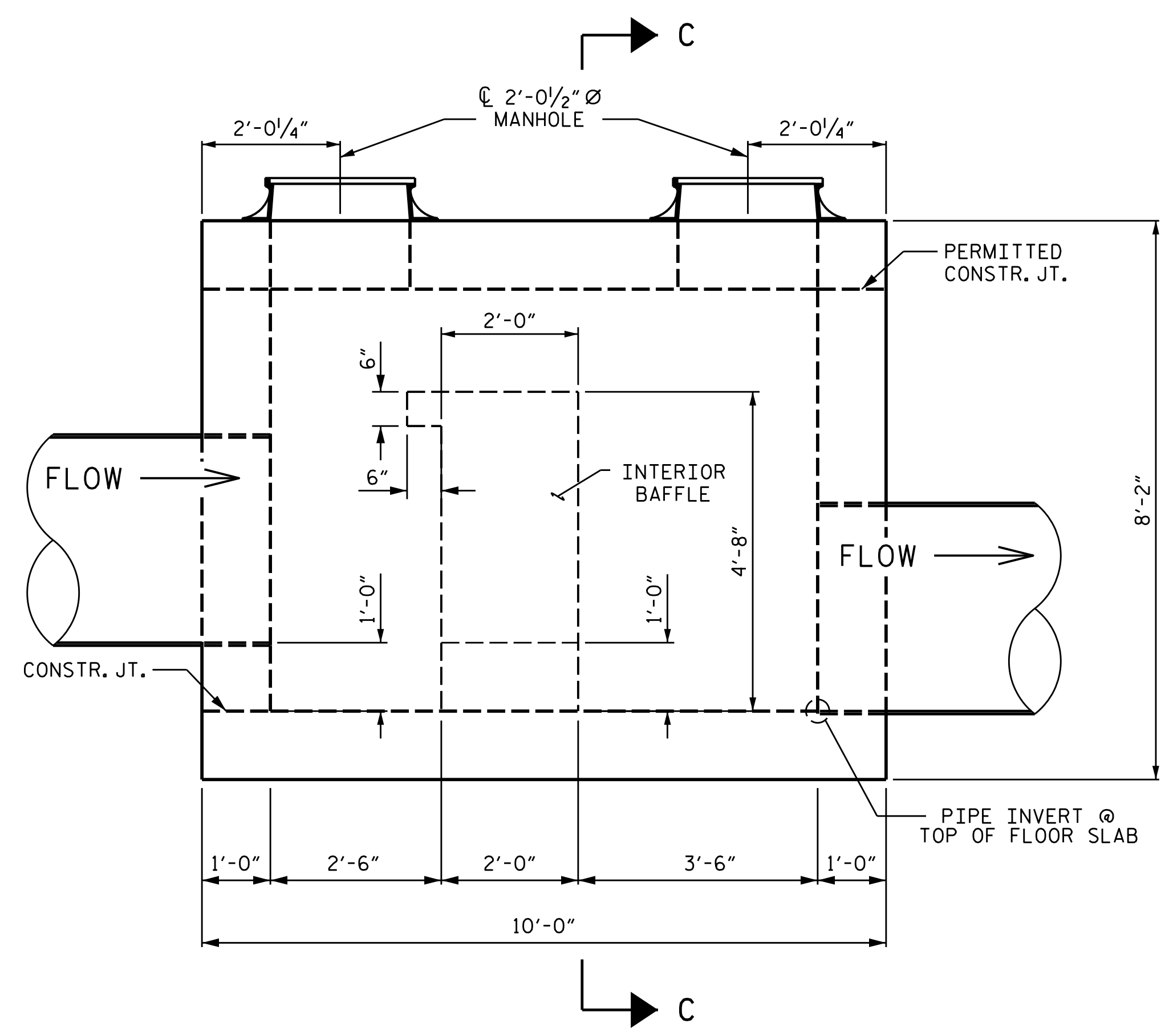

SIDE ELEVATION
FOR SECTION C-C, SEE SHEET 2 OF 3.

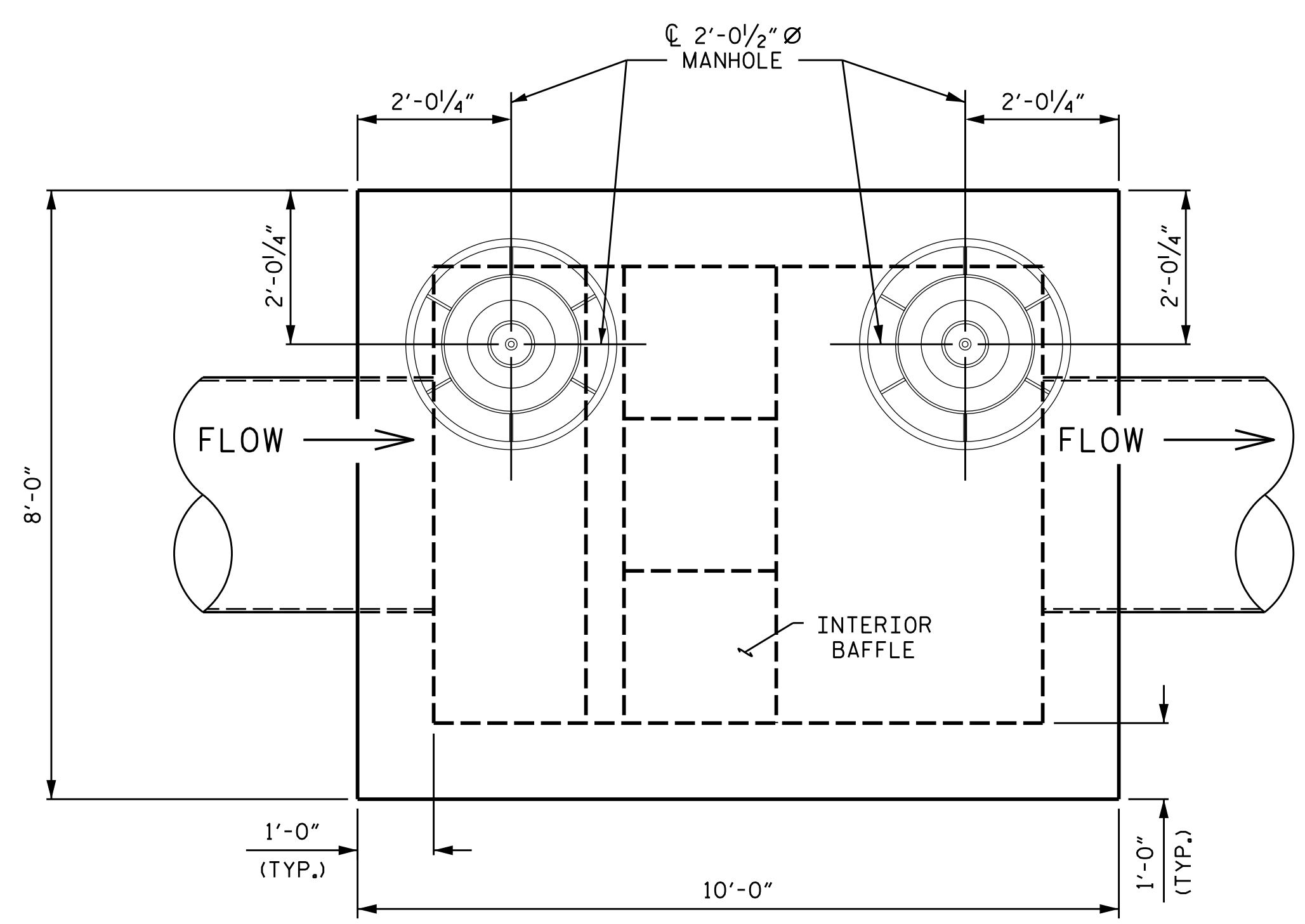

PLAN VIEW

DRAWN BY : STM DATE : 01/21
CHECKED BY : MGC DATE : 03/21

4/13/2021
X:\NCDOT\I-26 Howard Gap Rd Rehab\Structures\Energy Dissipator\I-26.SMU. ED.dgn
User:smassinople

SHEET 1 OF 3

STATE OF NORTH CAROLINA
DEPARTMENT OF TRANSPORTATION
RALEIGH

**ENERGY DISSIPATOR
JUNCTION BOX**

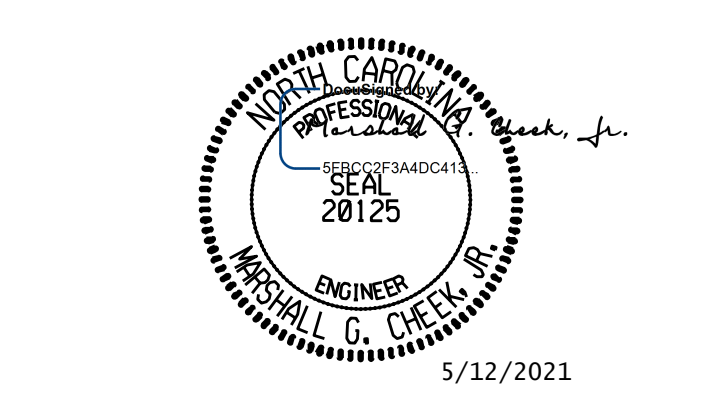

DOCUMENT NOT CONSIDERED FINAL
UNLESS ALL SIGNATURES COMPLETED

TGS ENGINEERS
706 HILLSBOROUGH STREET
SUITE 200
RALEIGH, NC 27603
PH (919) 773-8887
CORP. LICENSE NO.: C-0275

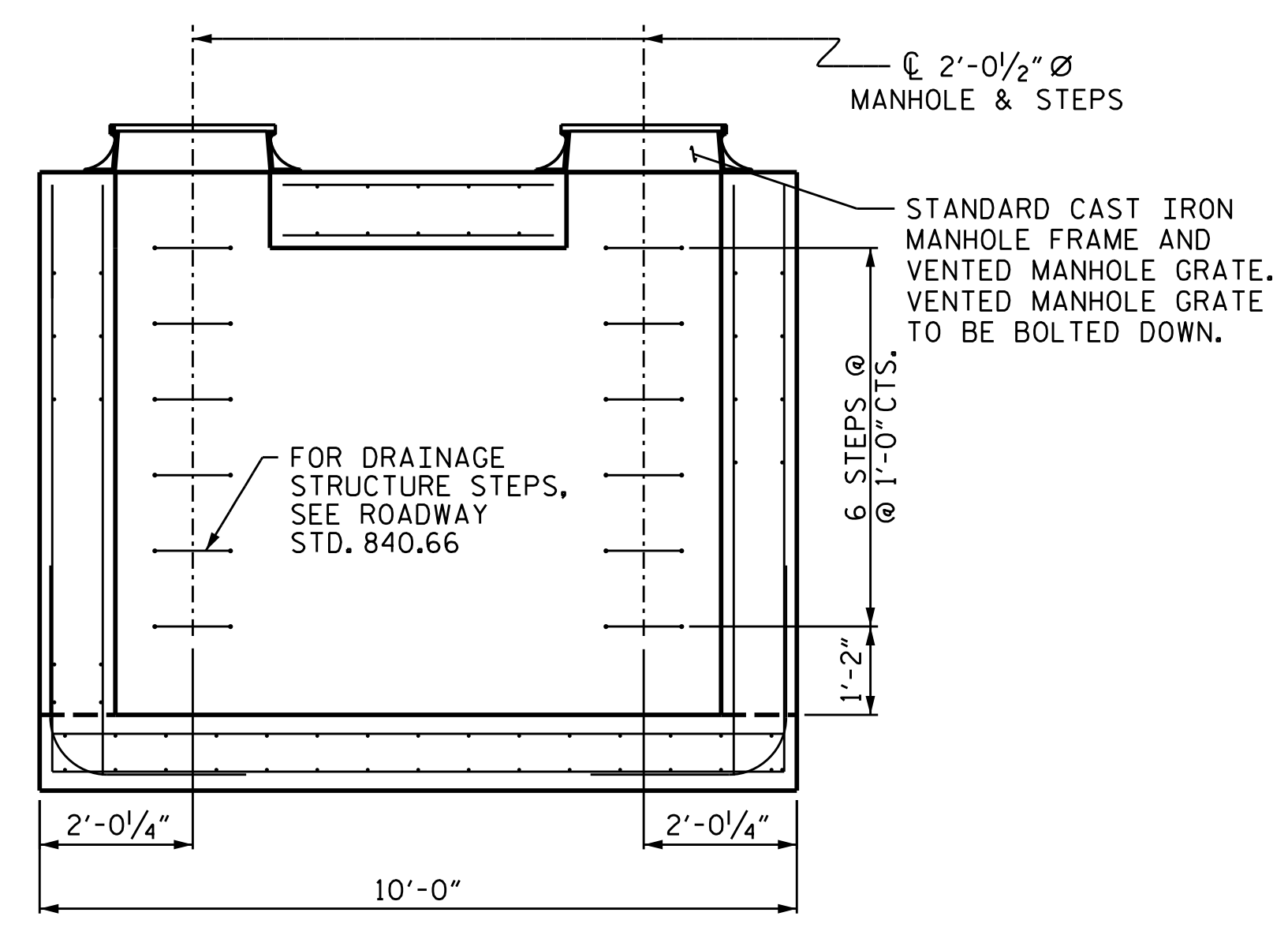

SECTION A-A

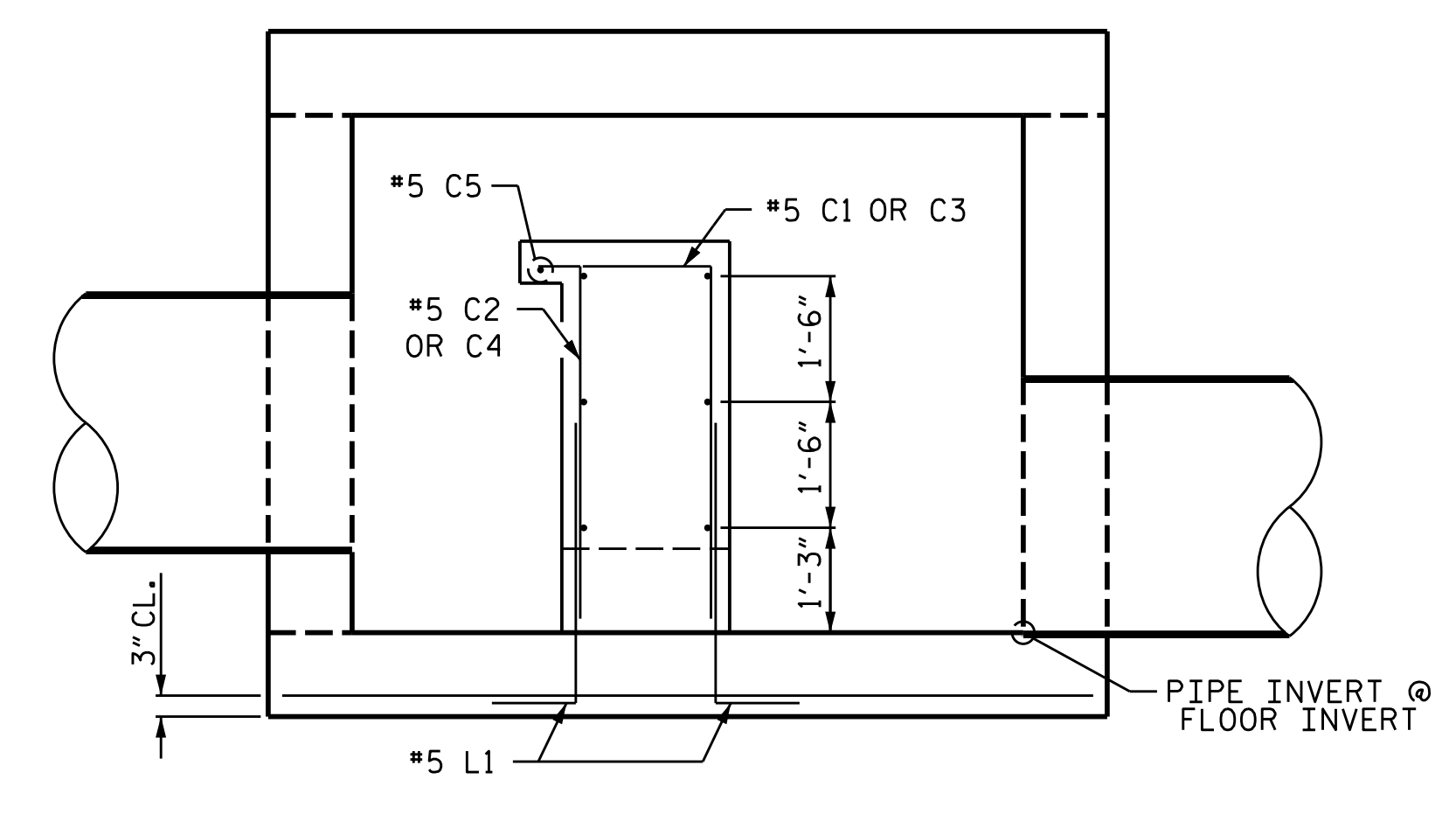

SECTION D-D

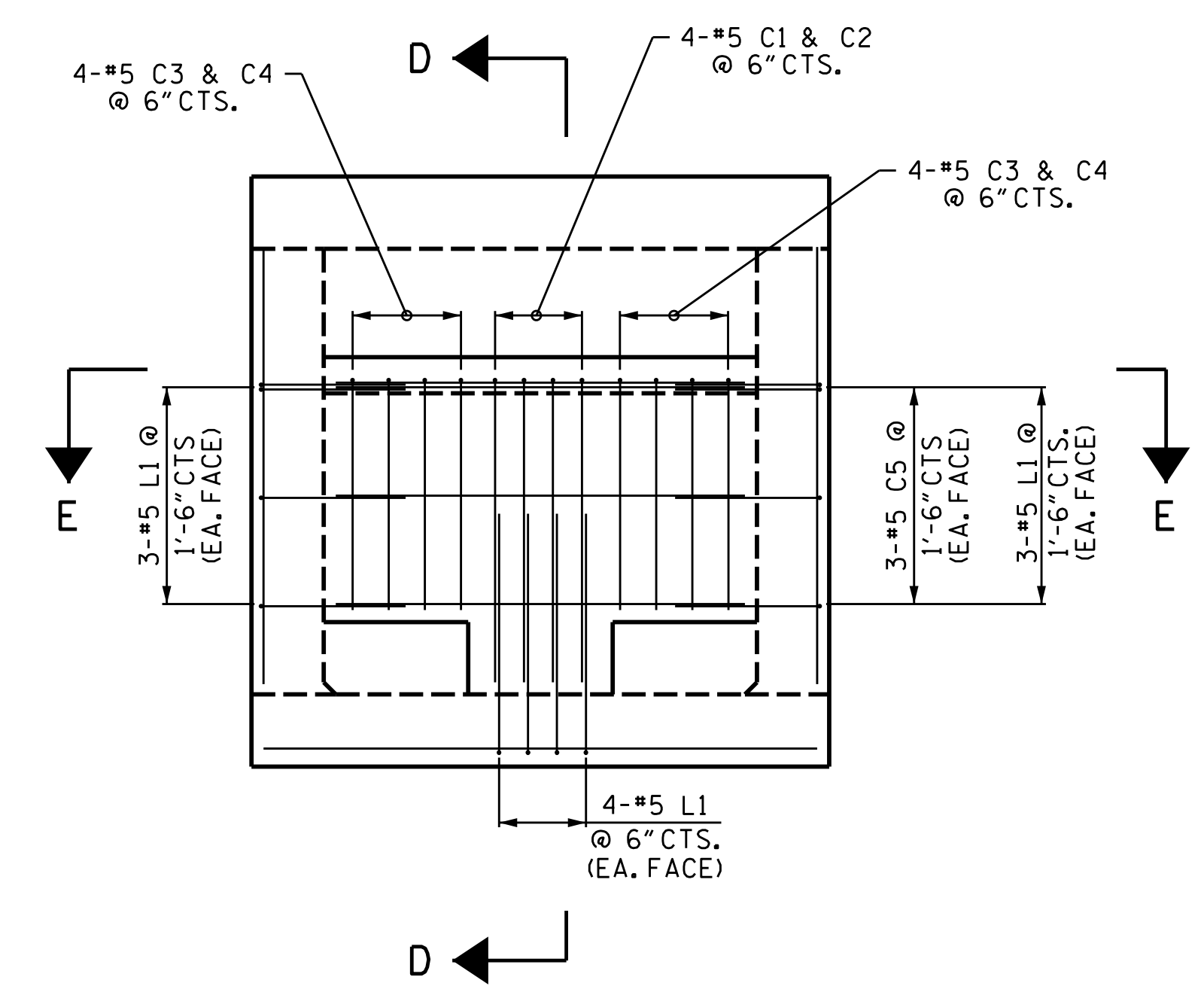

INTERIOR BAFFLE DETAIL

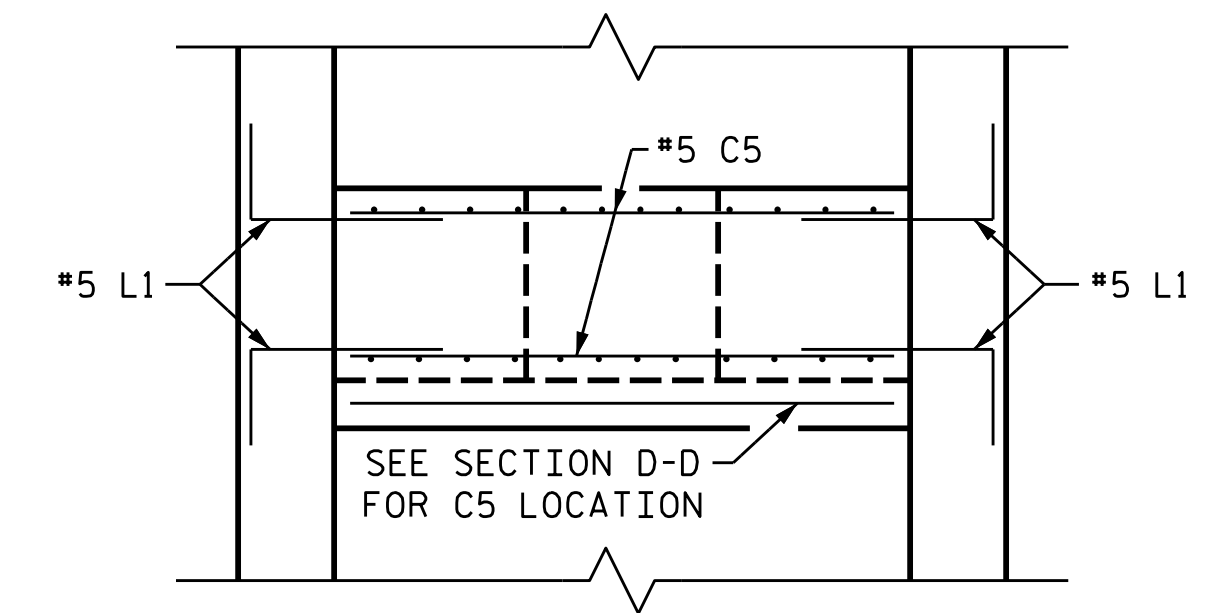

SECTION E-E

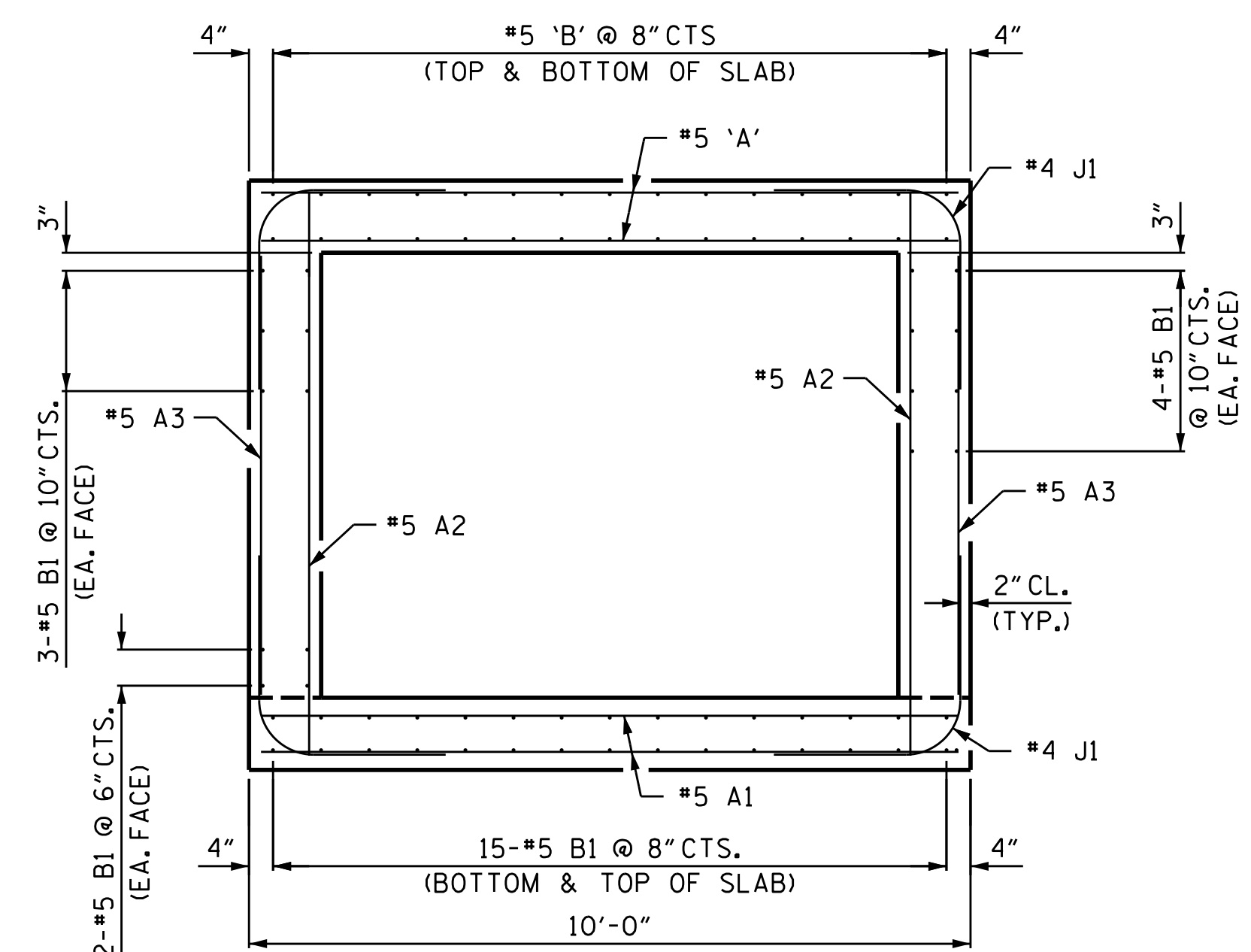

SECTION B-B

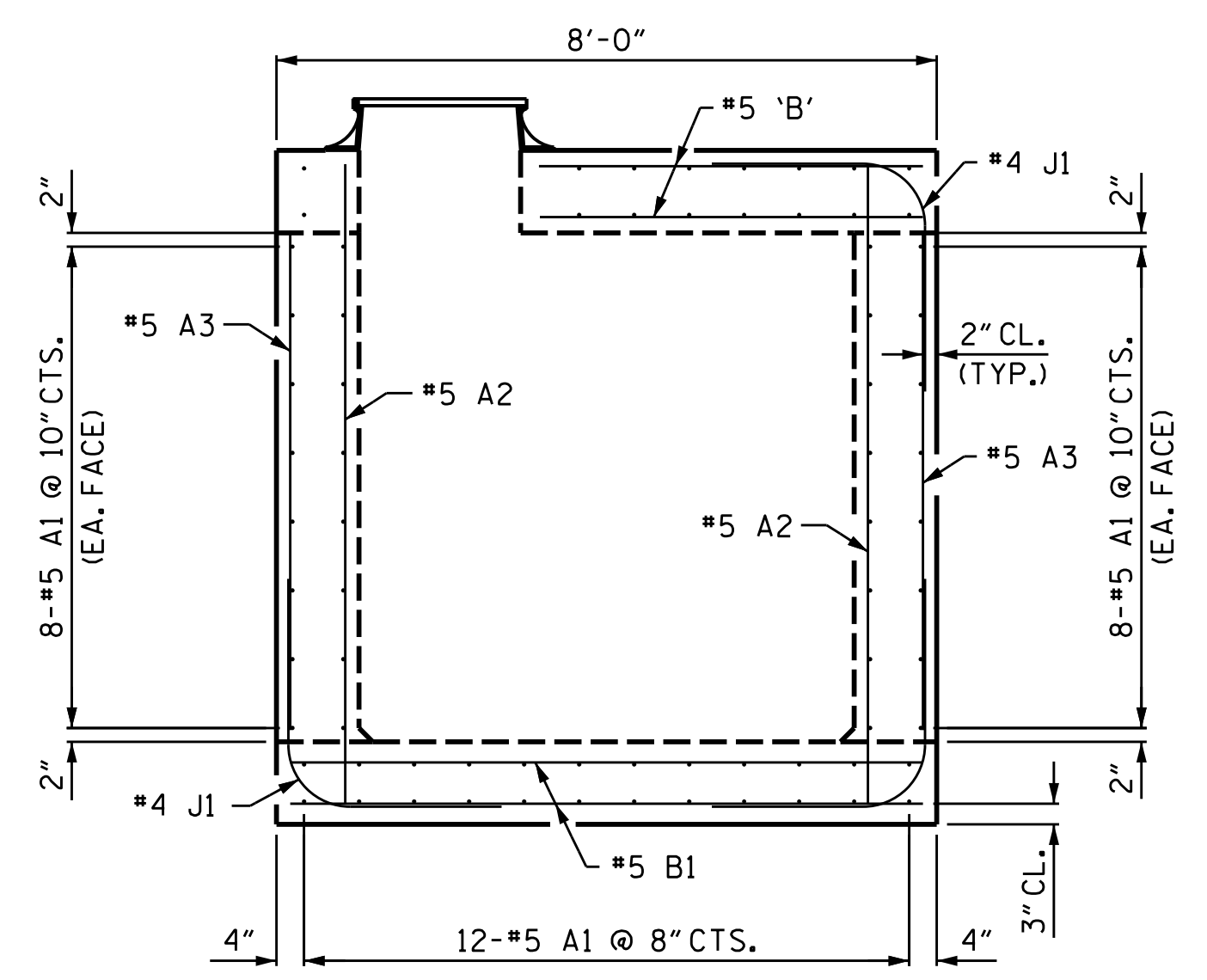

SECTION C-C

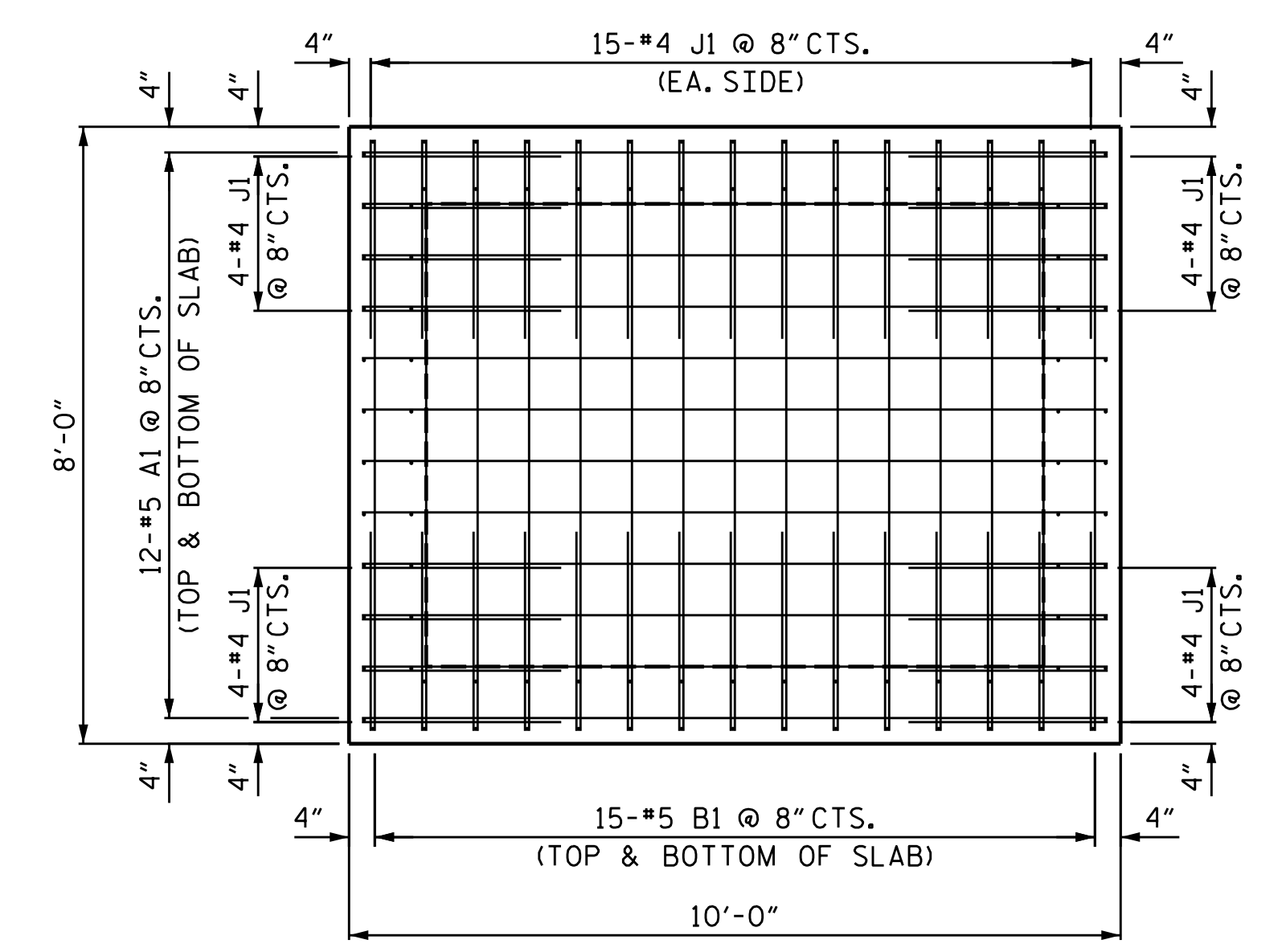

FLOOR SLAB

SHEET 2 OF 3

STATE OF NORTH CAROLINA
DEPARTMENT OF TRANSPORTATION
RALEIGH

ENERGY DISSIPATOR
JUNCTION BOX

DRAWN BY : STM DATE : 01/21
CHECKED BY : MGC DATE : 03/21

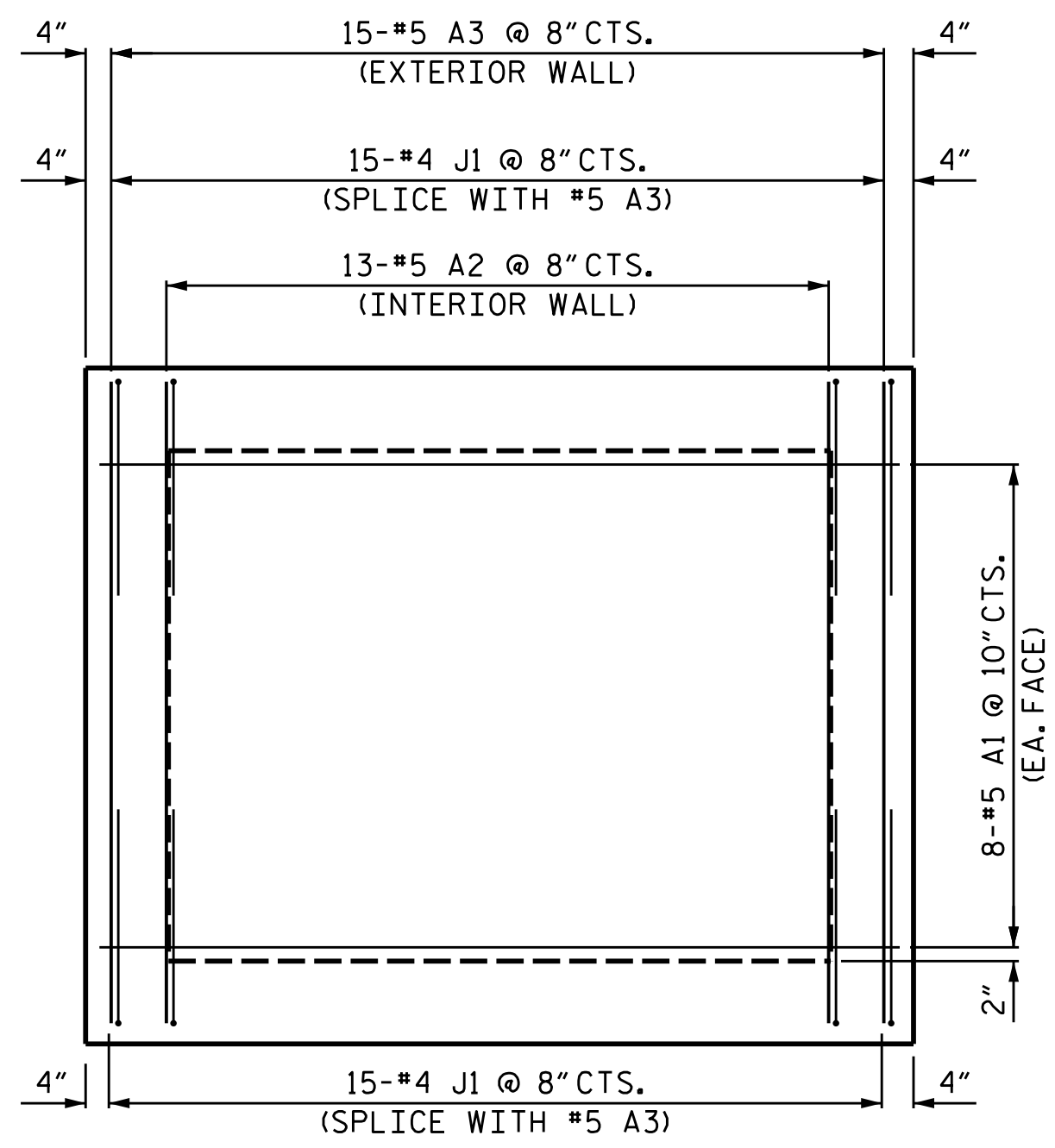

VIEW Z-Z

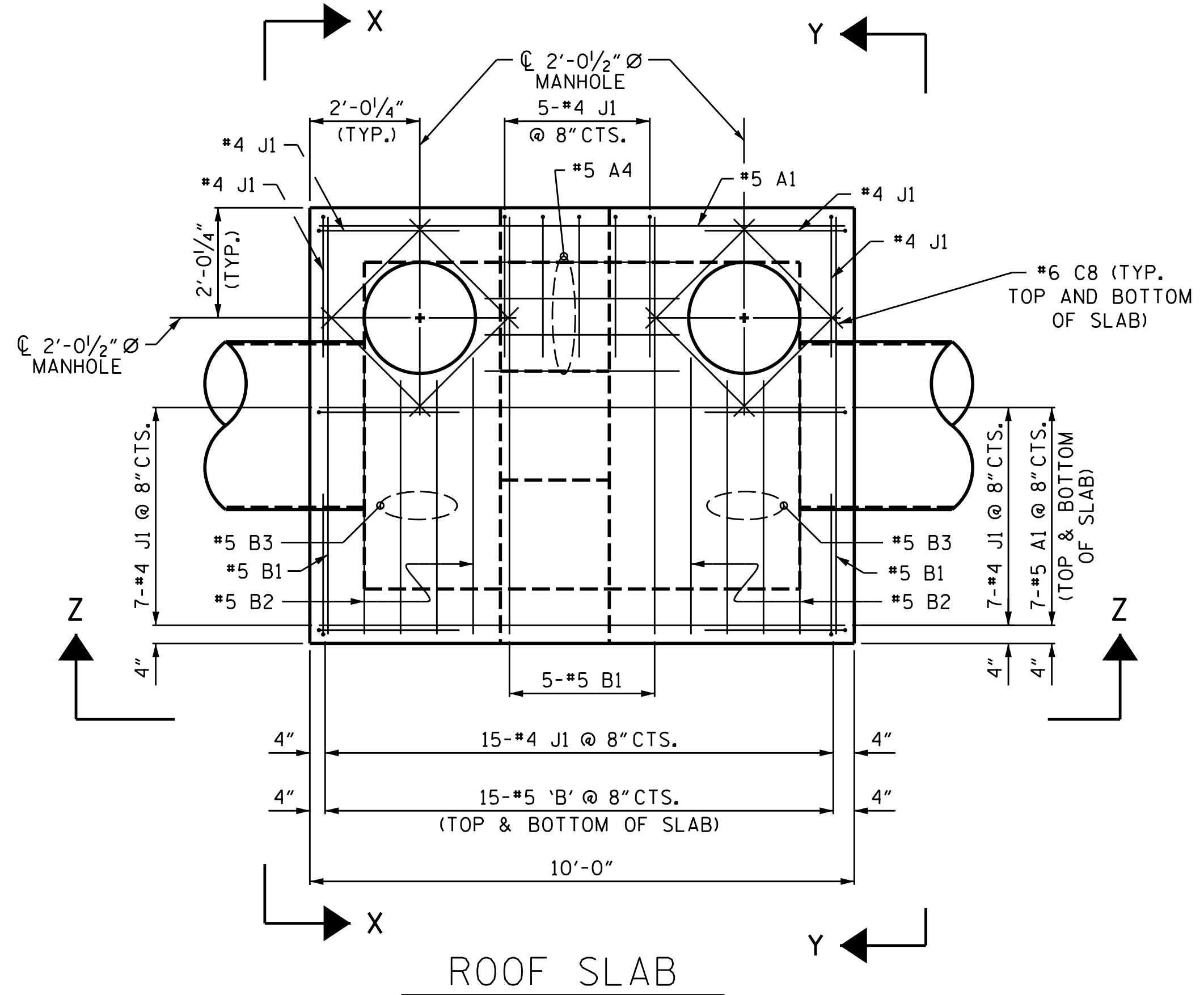

ROOF SLAB

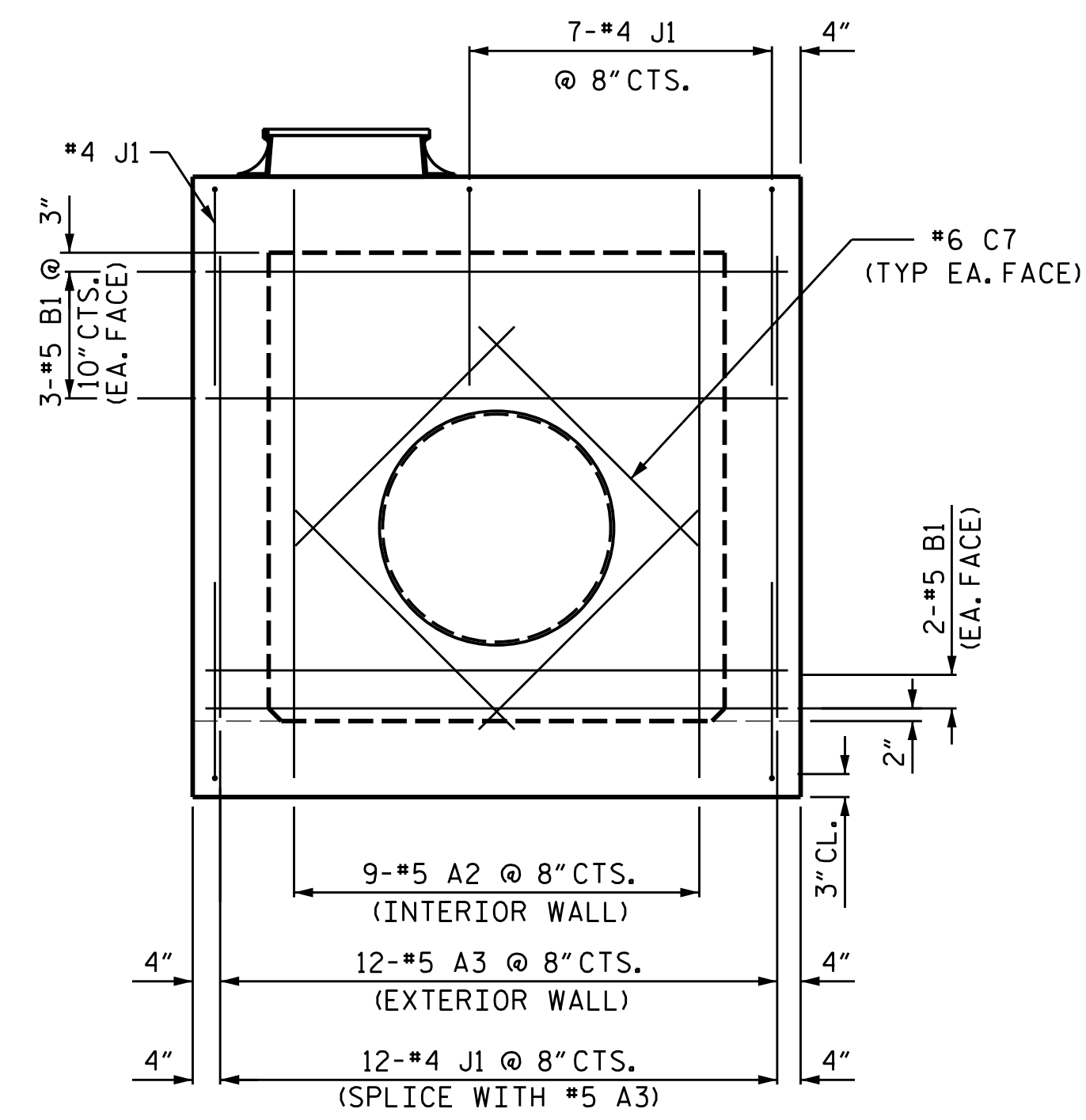

VIEW X-X

*5 A BARS SHALL BE FIELD CUT AS NECESSARY FOR INSTALLATION OF THE PIPE

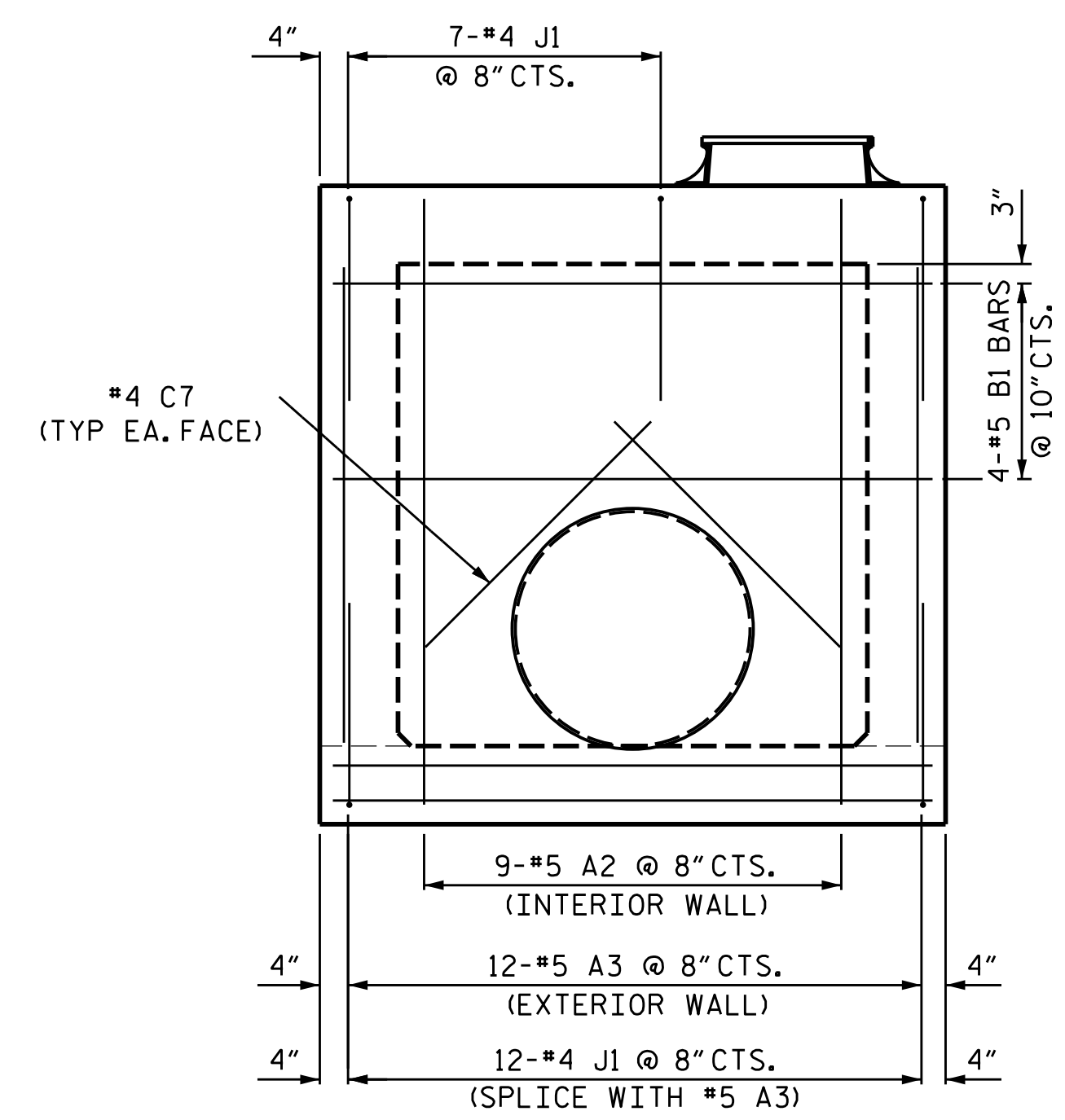

VIEW Y-Y

*5 A BARS SHALL BE FIELD CUT AS NECESSARY FOR INSTALLATION OF THE PIPE

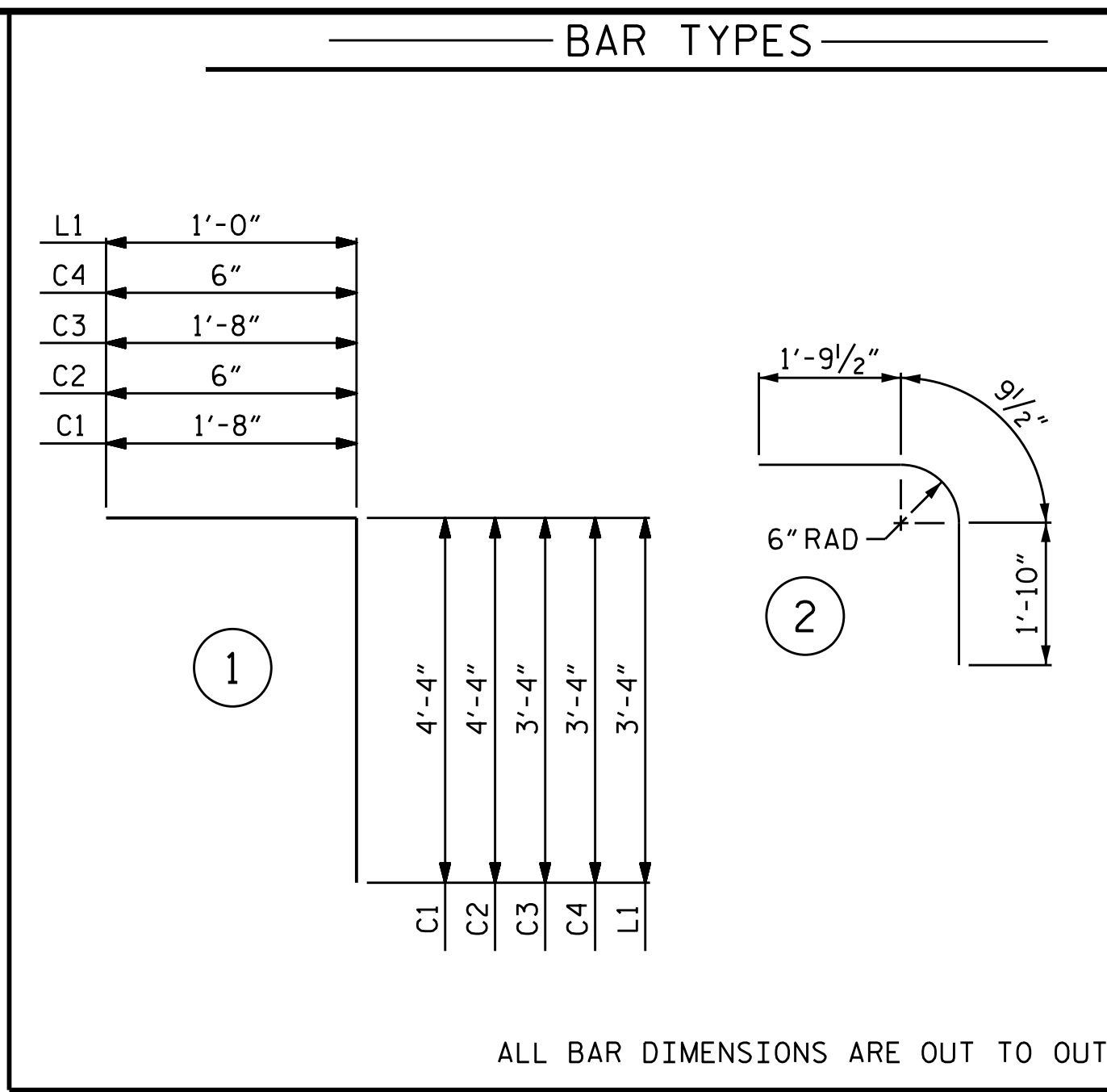

ALL BAR DIMENSIONS ARE OUT TO OUT.

PROJECT REFERENCE NO.		SHEET NO.			
15614J075010		2D-3			
BILL OF MATERIAL					
BAR	NUMBER	SIZE	TYPE	LENGTH	WEIGHT
A1	72	#5	STR	9'-8"	726
A2	44	#5	STR	7'-9"	356
A3	54	#5	STR	6'-1"	343
A4	8	#5	STR	3'-6"	29
B1	62	#5	STR	7'-8"	496
B2	8	#5	STR	5'-1"	42
B3	8	#5	STR	4'-6"	38
C1	4	#5	1	6'-0"	25
C2	4	#5	1	4'-10"	20
C3	8	#5	1	5'-0"	42
C4	8	#5	1	3'-10"	32
C5	7	#5	STR	5'-8"	41
C7	12	#6	STR	4'-11"	89
C8	16	#6	STR	2'-10"	68
J1	84	#4	2	4'-5"	248
L1	20	#5	1	4'-4"	90
REINFORCING STEEL				2685 LBS.	
CLASS B CONCRETE				14.6 C.Y.	

NOTES

- DIMENSIONS MAY BE FIELD ADJUSTED AS DIRECTED BY THE ENGINEER.
- CHAMFER ALL EXPOSED CORNERS 1".
- CORRUGATED STEEL PIPES SHALL BE LOCATED BY THE ENGINEER.
- FOR MANHOLE FRAME AND VENTED MANHOLE GRATE, SEE SPECIAL PROVISIONS.

DRAWN BY : STM DATE : 02/21
 CHECKED BY : MGC DATE : 03/21

4/13/2021
 X:\NGDOT\I-26 Howard Gap Rd Rehab\Structures\Energy Dissipator\I-26.SMU. ED.dgn
 Users\smasinnopie

DOCUMENT NOT CONSIDERED FINAL
 UNLESS ALL SIGNATURES COMPLETED
TGS ENGINEERS
 706 HILLSBOROUGH STREET
 SUITE 200
 RALEIGH, NC 27603
 PH (919) 773-8887
 CORP. LICENSE NO.: C-0275

SHEET 3 OF 3
 STATE OF NORTH CAROLINA
 DEPARTMENT OF TRANSPORTATION
 RALEIGH
**ENERGY DISSIPATOR
 JUNCTION BOX**

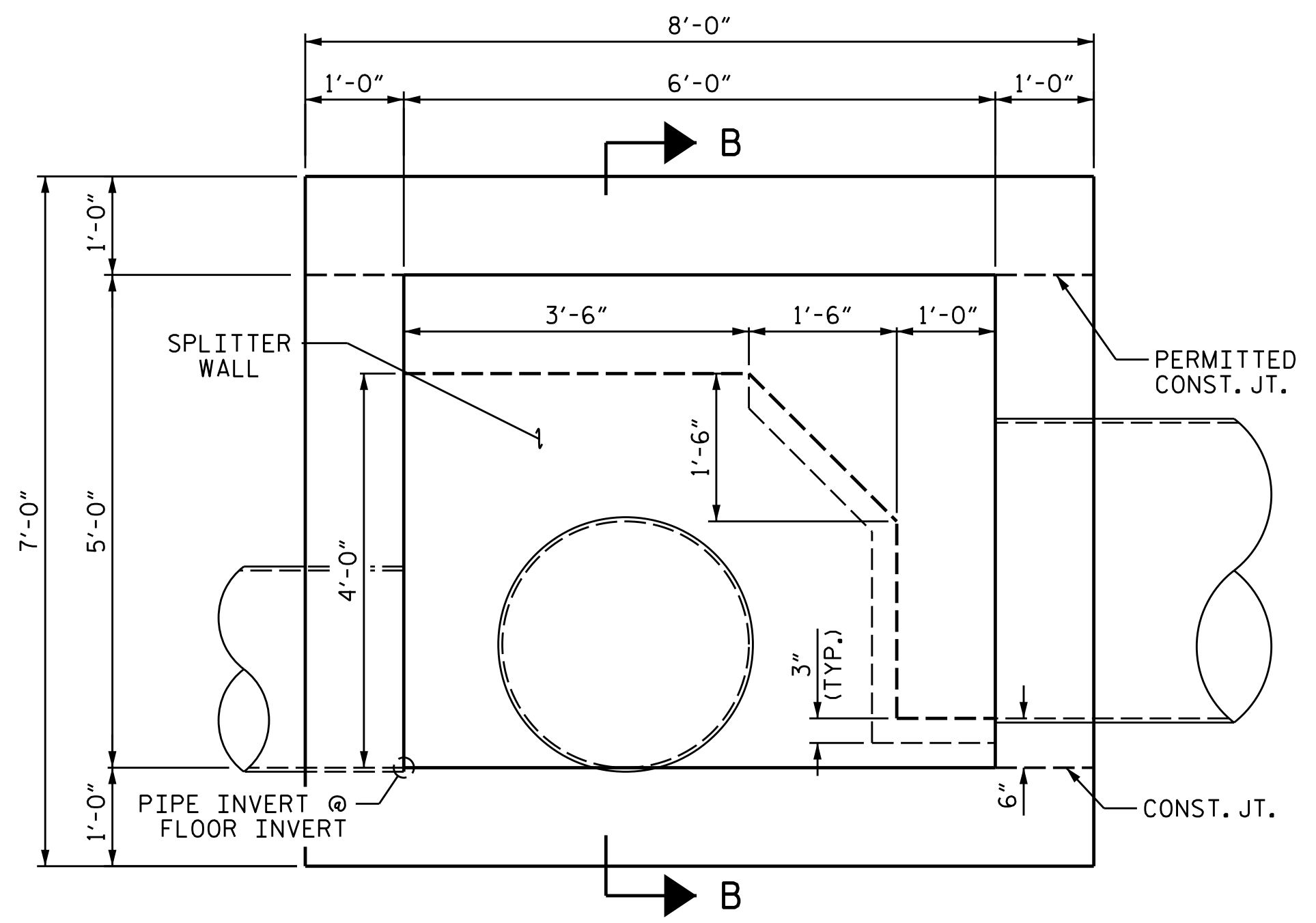

SIDE ELEVATION
FOR SECTION B-B, SEE SHEET 3 OF 4.

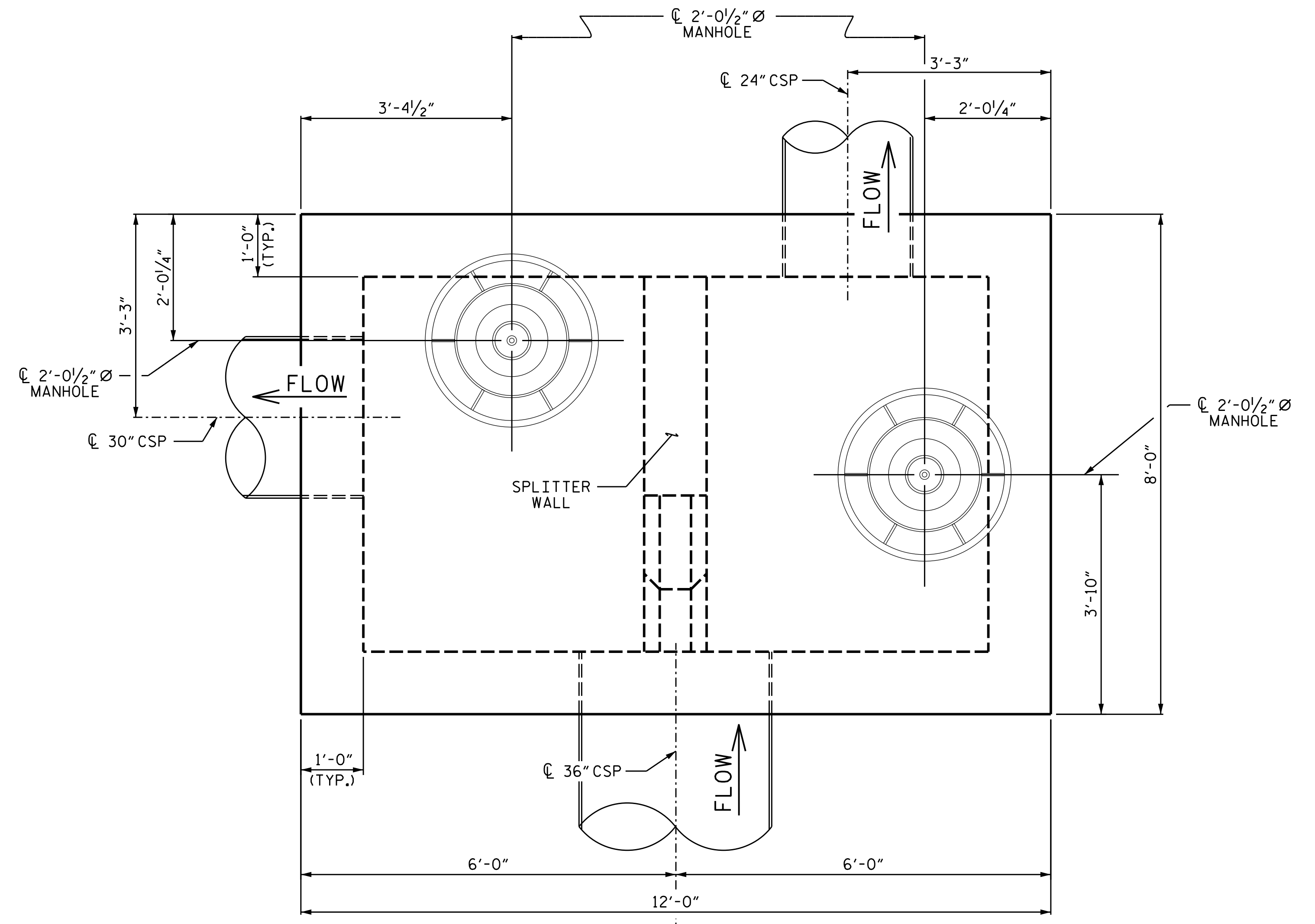

PLAN VIEW

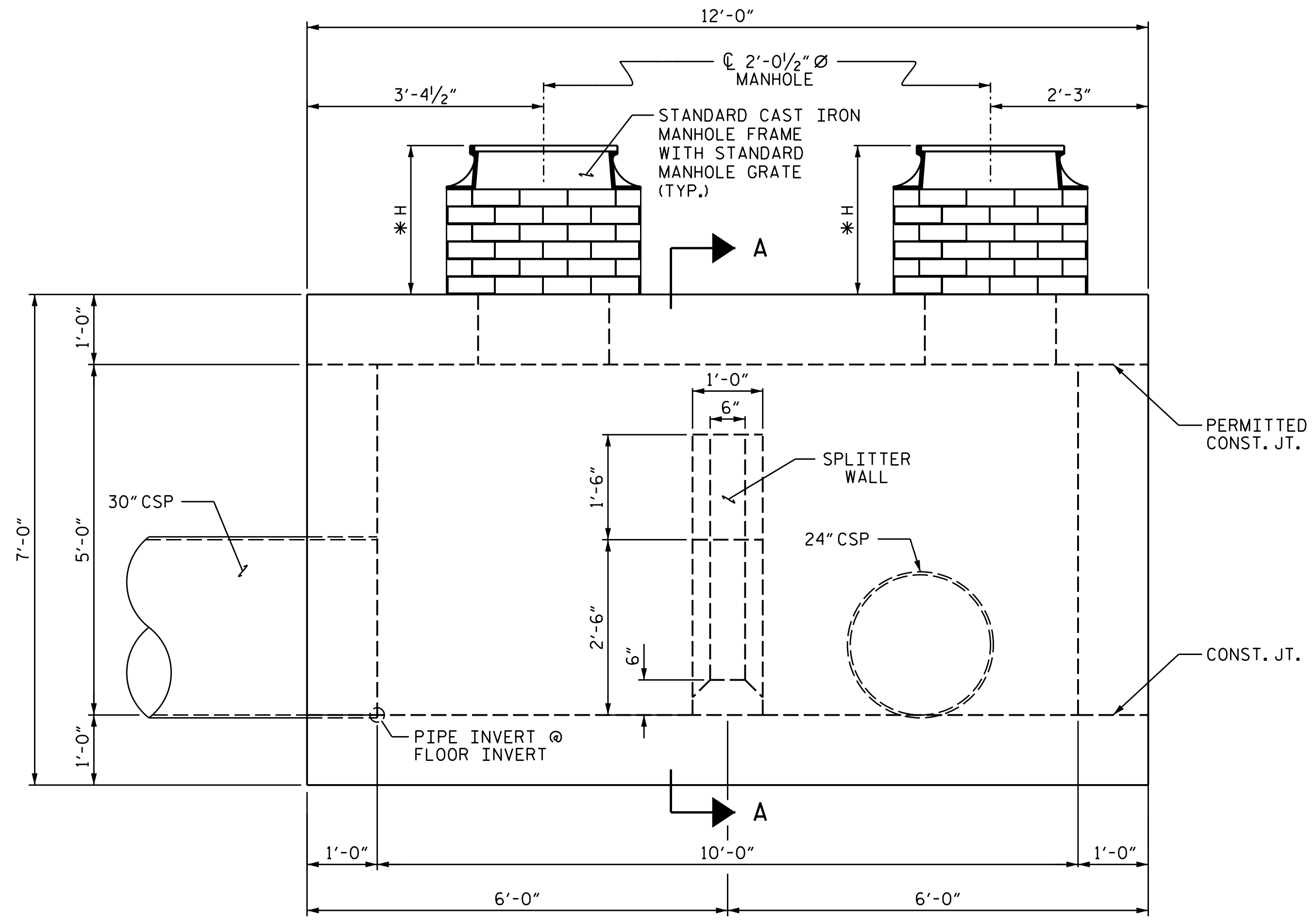

FRONT ELEVATION
FOR SECTION A-A, SEE SHEET 3 OF 4.

* H TO BE DETERMINED BY CONTRACTOR TO ENSURE MANHOLE COVER WILL BE AT FINISHED GRADE.

DRAWN BY : STM DATE : 02/21
CHECKED BY : MGC DATE : 03/21

5/12/2021

DOCUMENT NOT CONSIDERED FINAL UNLESS ALL SIGNATURES COMPLETED
TGS ENGINEERS
 706 HILLSBOROUGH STREET
 SUITE 200
 RALEIGH, NC 27603
 PH (919) 773-8887
 CORP. LICENSE NO.: C-0275

SHEET 1 OF 4
STATE OF NORTH CAROLINA
DEPARTMENT OF TRANSPORTATION
RALEIGH

SPLITTER BOX

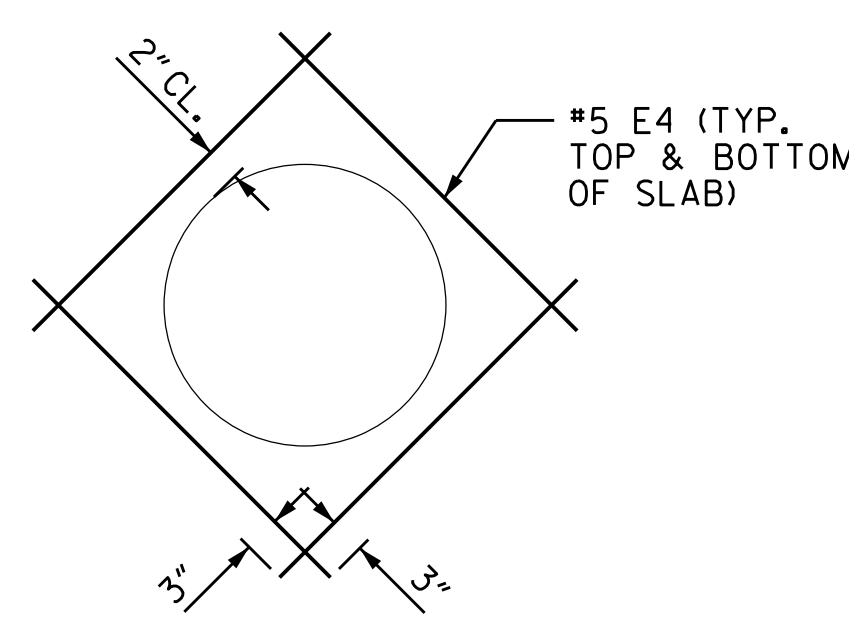
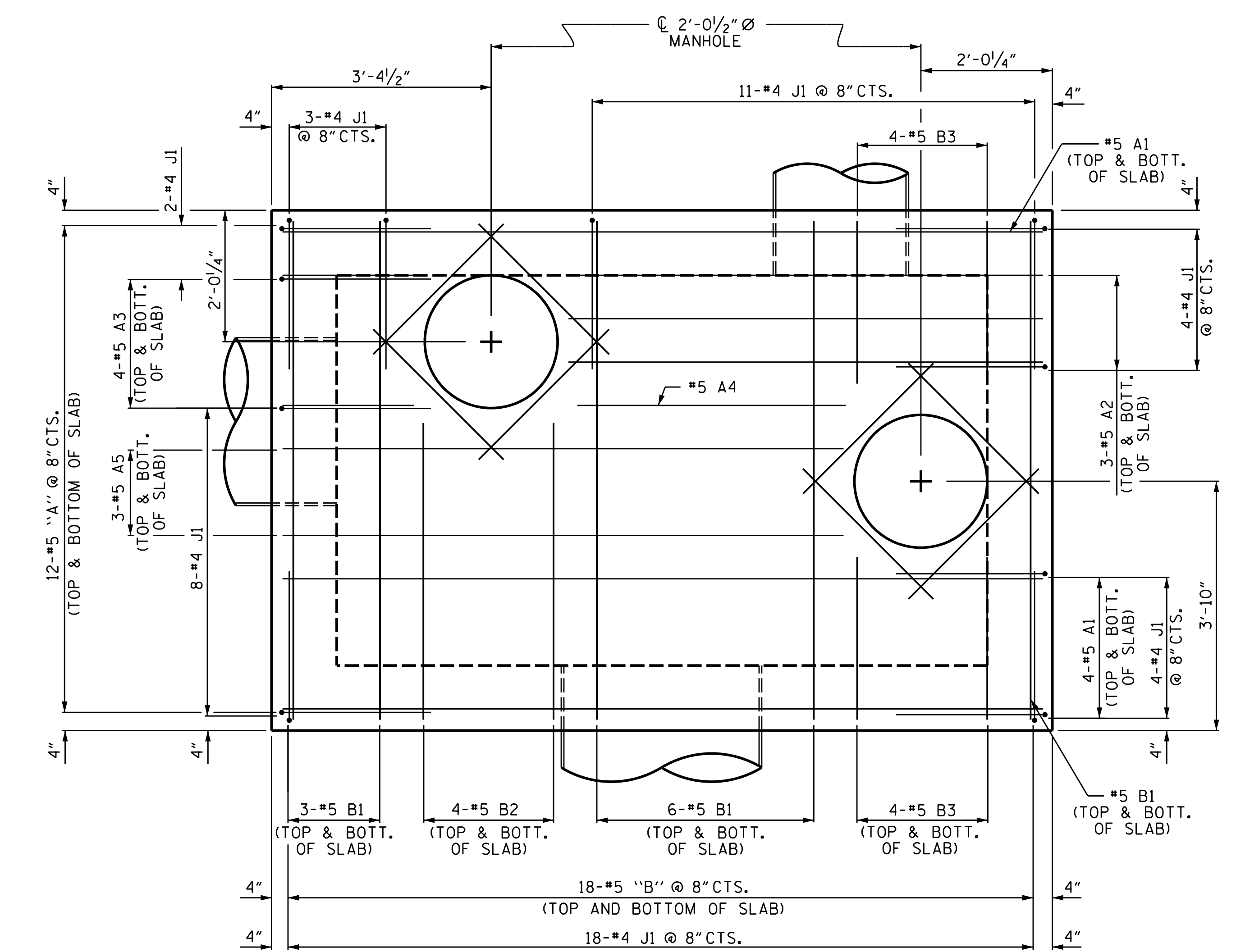
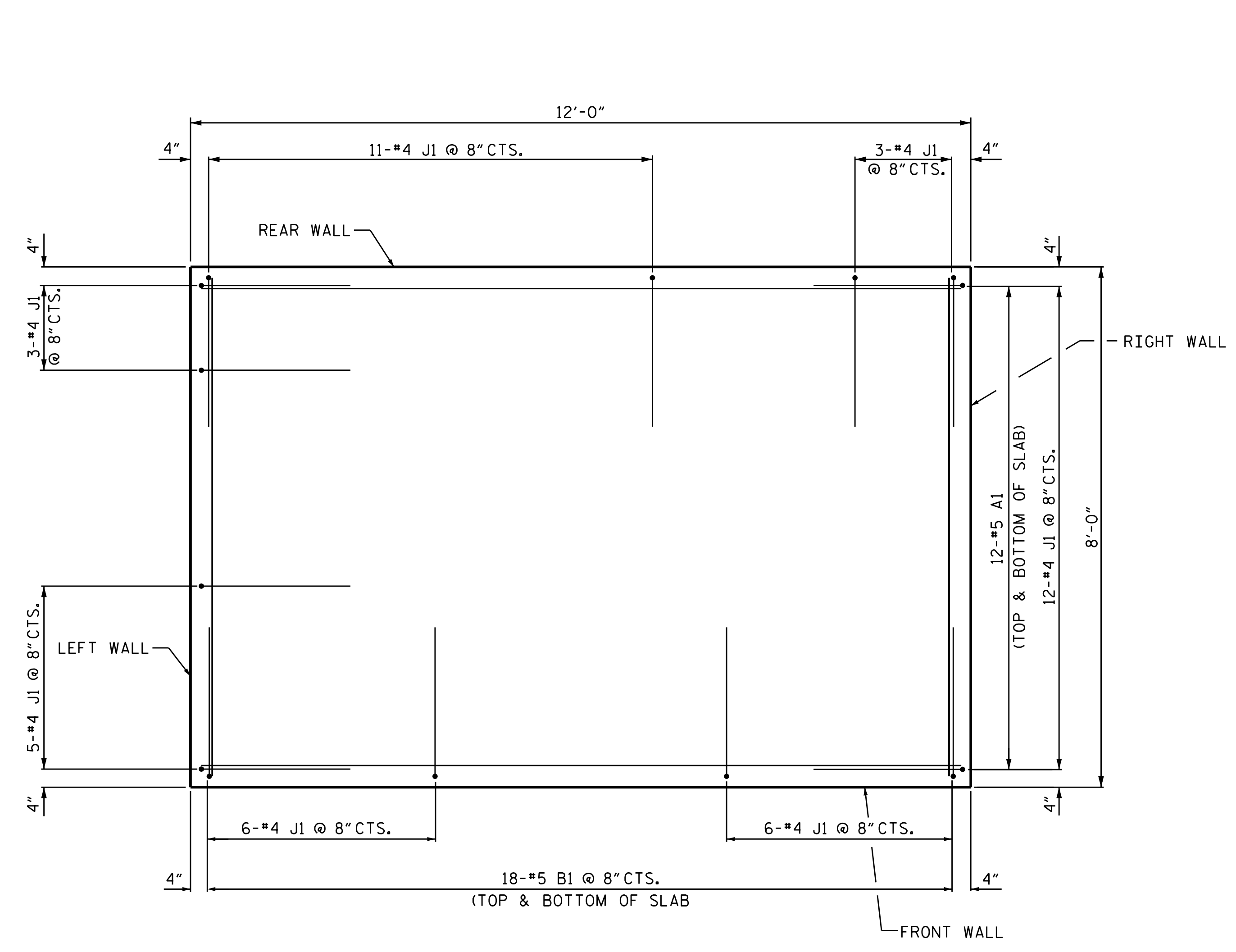

DRAWN BY : STM DATE : 02/21
 CHECKED BY : MGC DATE : 03/21

4/6/2021
 X:\MCDOT\I-26 Howard Gap Rd Rehab\Structures\Splitter Box\I-26.SMU. SB.dgn
 Users\smassinople

DOCUMENT NOT CONSIDERED FINAL
 UNLESS ALL SIGNATURES COMPLETED

TGS ENGINEERS
 706 HILLSBOROUGH STREET
 SUITE 200
 RALEIGH, NC 27603
 PH (919) 773-8887
 CORP. LICENSE NO.: C-0275

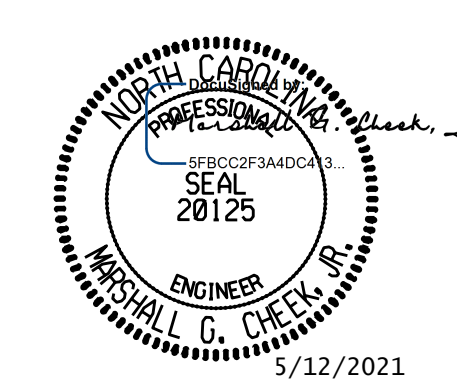

SHEET 2 OF 4

STATE OF NORTH CAROLINA
 DEPARTMENT OF TRANSPORTATION
 RALEIGH

SPLITTER BOX

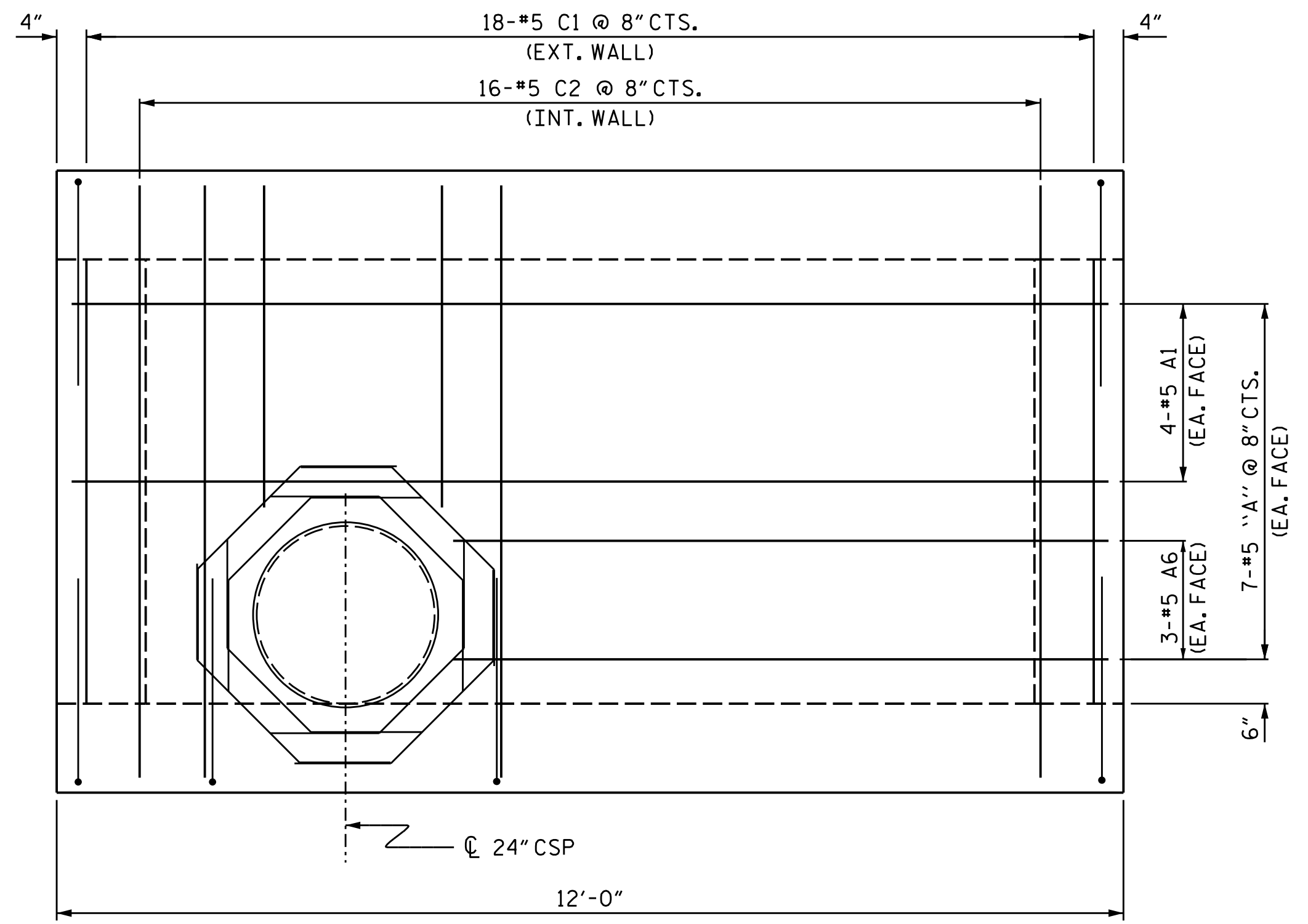

REAR WALL
 SEE "DETAIL A" FOR 24" CSP REINFORCEMENT.
 #5 "C" BARS SHALL BE FIELD CUT AS NECESSARY
 FOR INSTALLATION OF THE 24" CSP.

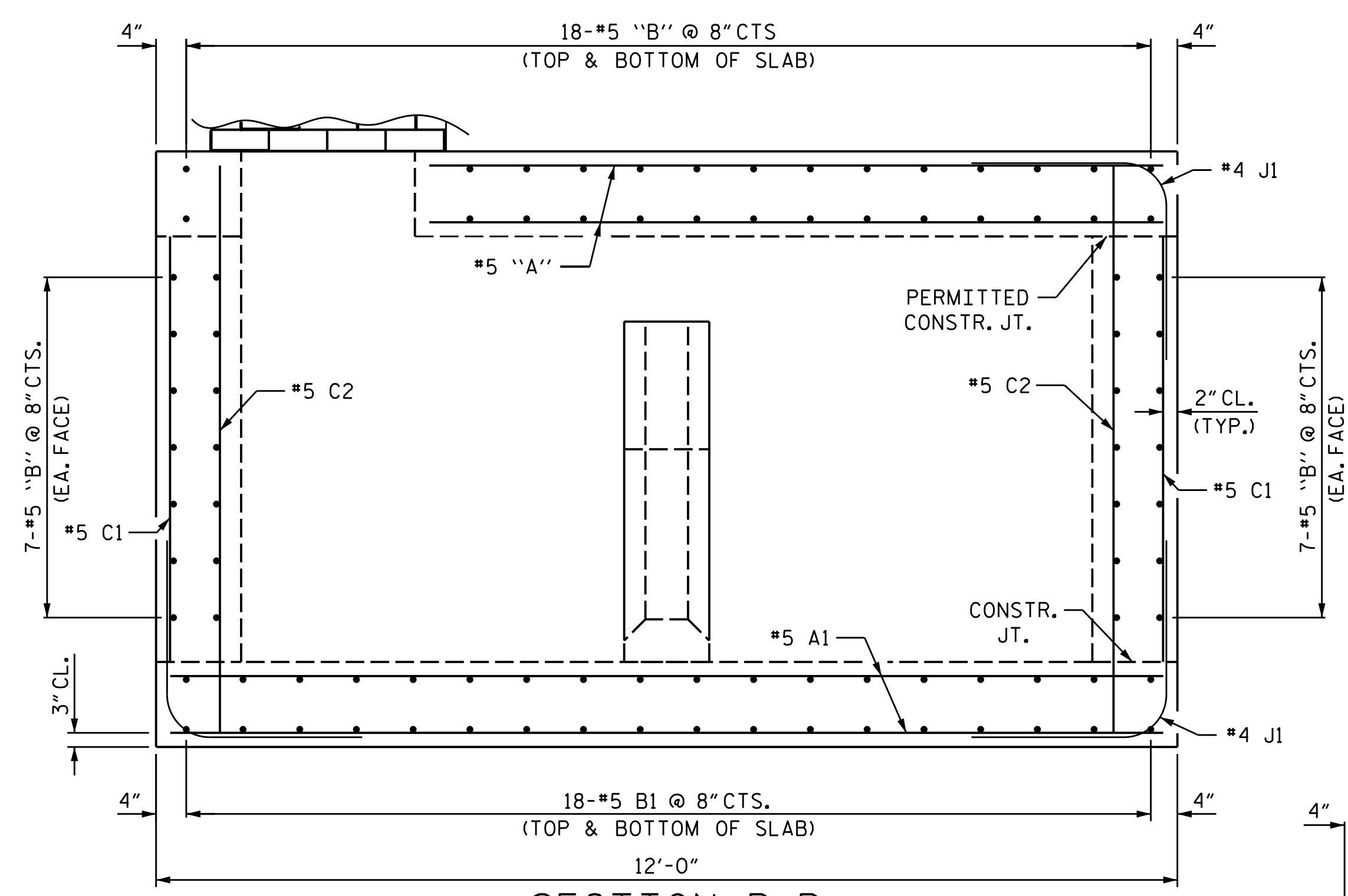

SECTION B-B

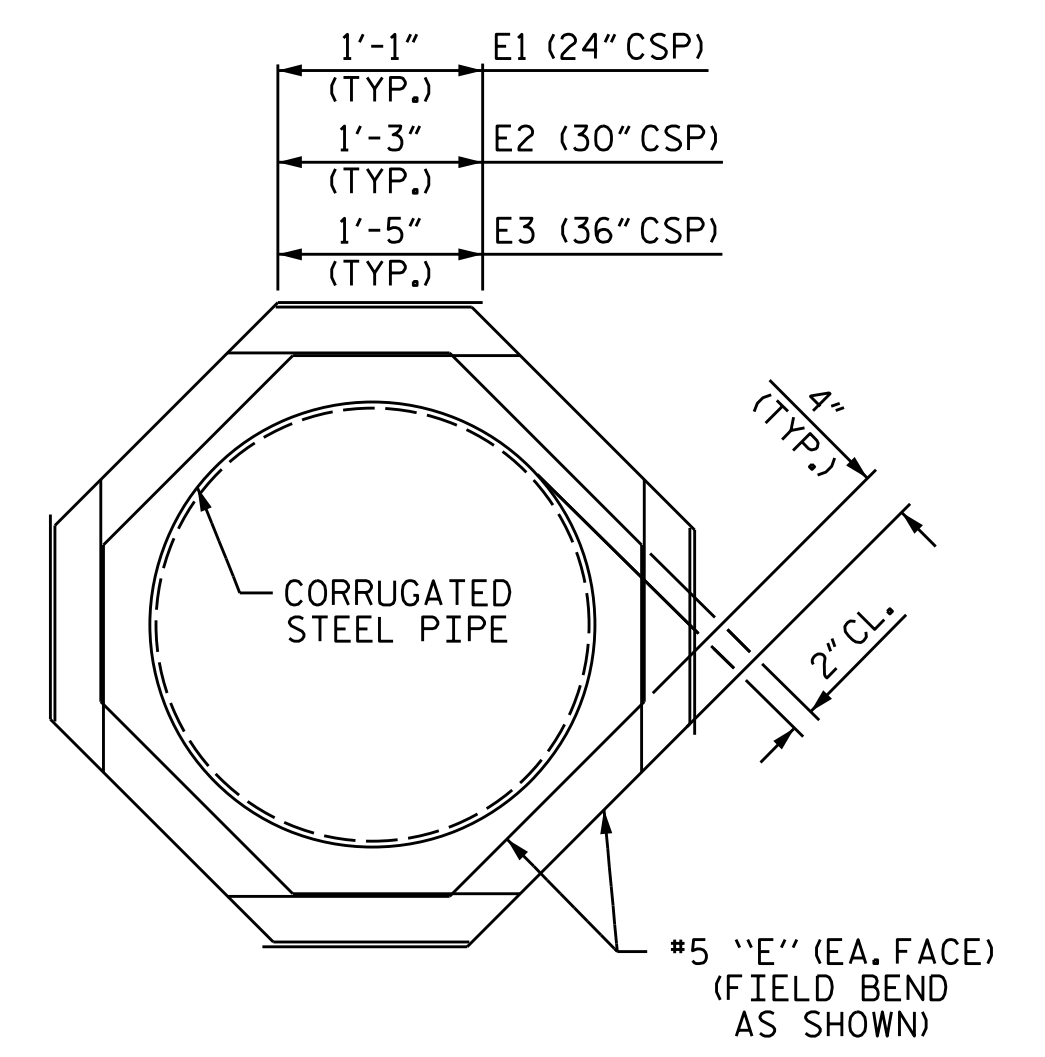

DETAIL "A"
 THE PIPE THROUGH THE WALL OF THE SPLITTER BOX WILL
 BE LOCATED BY THE ENGINEER. THE REINFORCING STEEL WILL BE
 CUT & FIELD BENT AS NECESSARY TO CLEAR THE PIPE

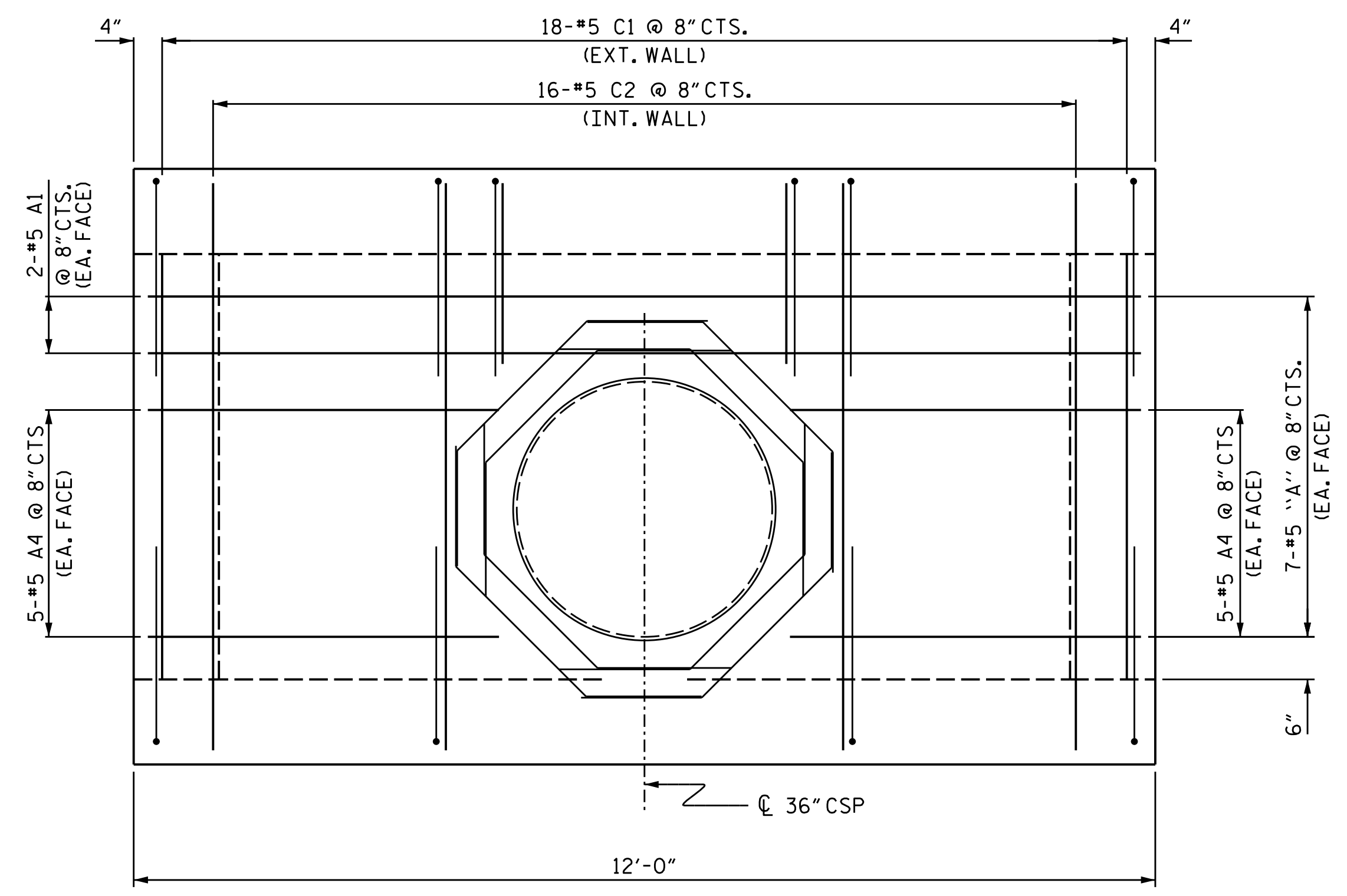

FRONT WALL
 SEE "DETAIL A" FOR 36" CSP REINFORCEMENT.
 #5 "C" BARS SHALL BE FIELD CUT AS NECESSARY
 FOR INSTALLATION OF THE 36" CSP.

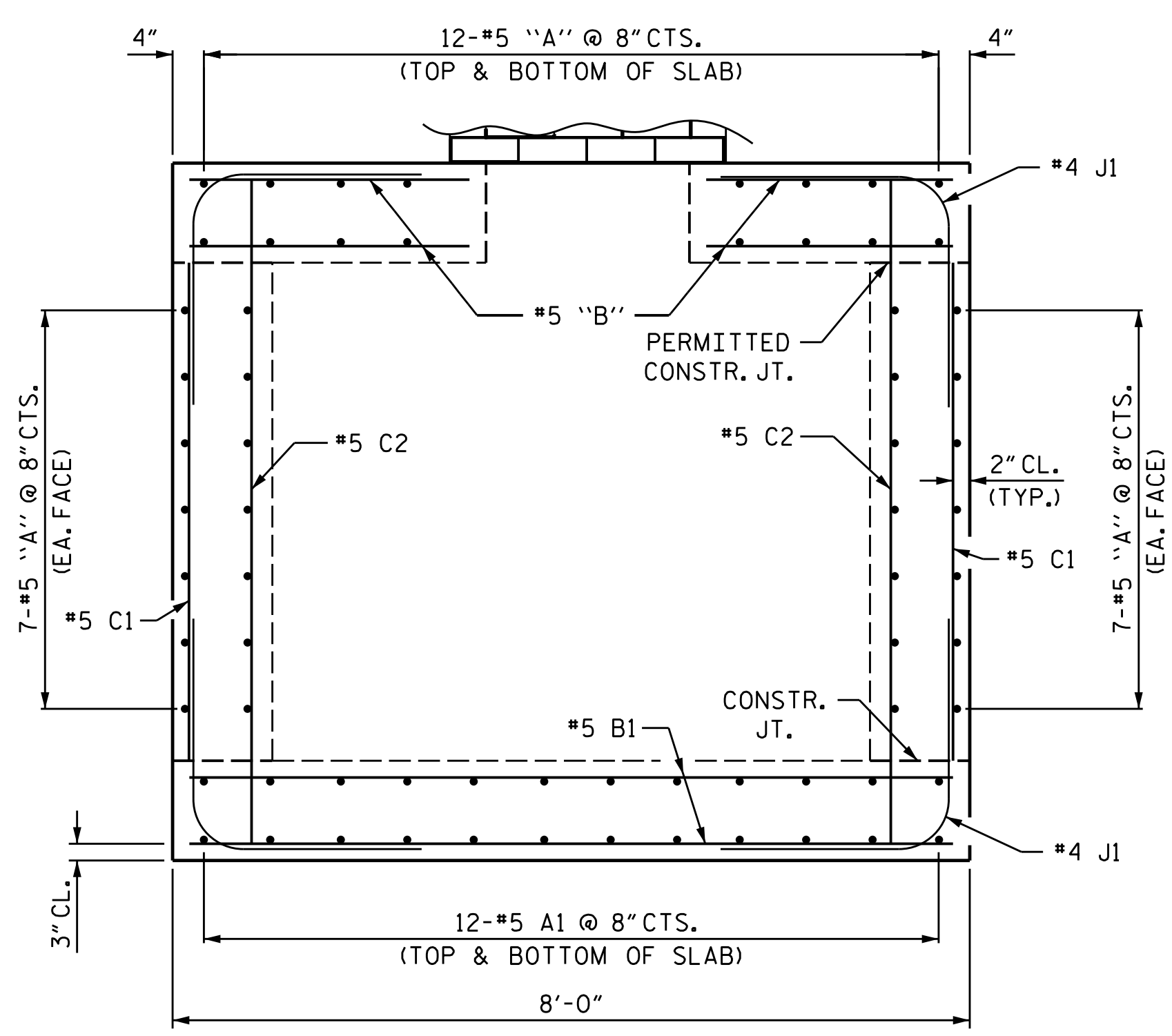

SECTION A-A

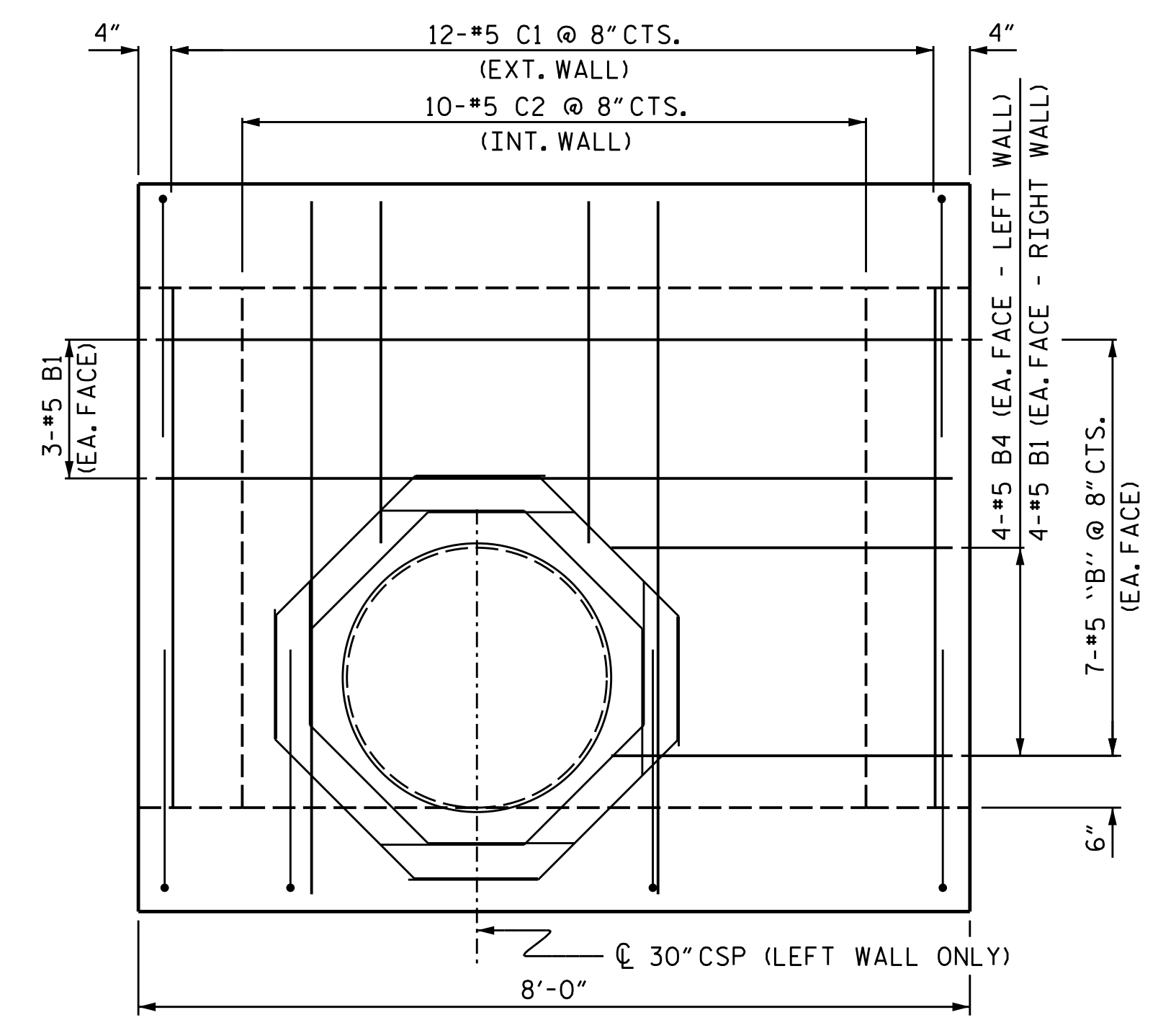

LEFT/RIGHT WALL
 SEE "DETAIL A" FOR 30" CSP REINFORCEMENT.
 #5 "C" BARS SHALL BE FIELD CUT AS NECESSARY
 FOR INSTALLATION OF THE 30" CSP.

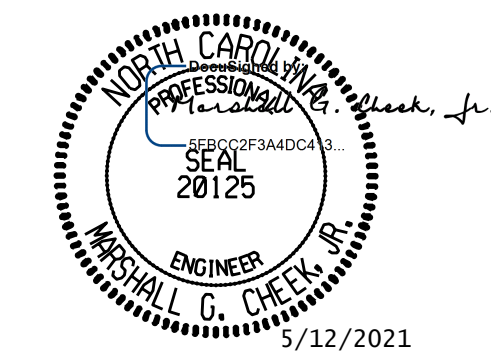

SHEET 3 OF 4
 STATE OF NORTH CAROLINA
 DEPARTMENT OF TRANSPORTATION
 RALEIGH

SPLITTER BOX

DRAWN BY : STM DATE : 02/21
 CHECKED BY : MGC DATE : 03/21

DOCUMENT NOT CONSIDERED FINAL
 UNLESS ALL SIGNATURES COMPLETED
 TGS ENGINEERS
 706 HILLSBOROUGH STREET
 SUITE 200
 RALEIGH, NC 27603
 PH (919) 773-8887
 CORP. LICENSE NO.: C-0275

BAR TYPES

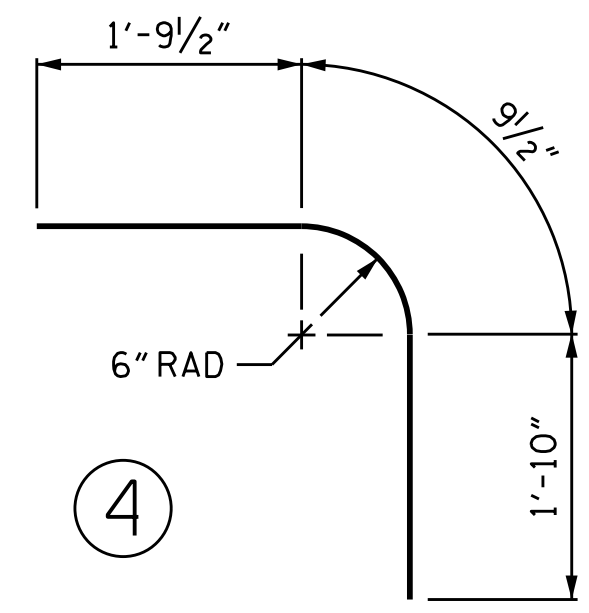
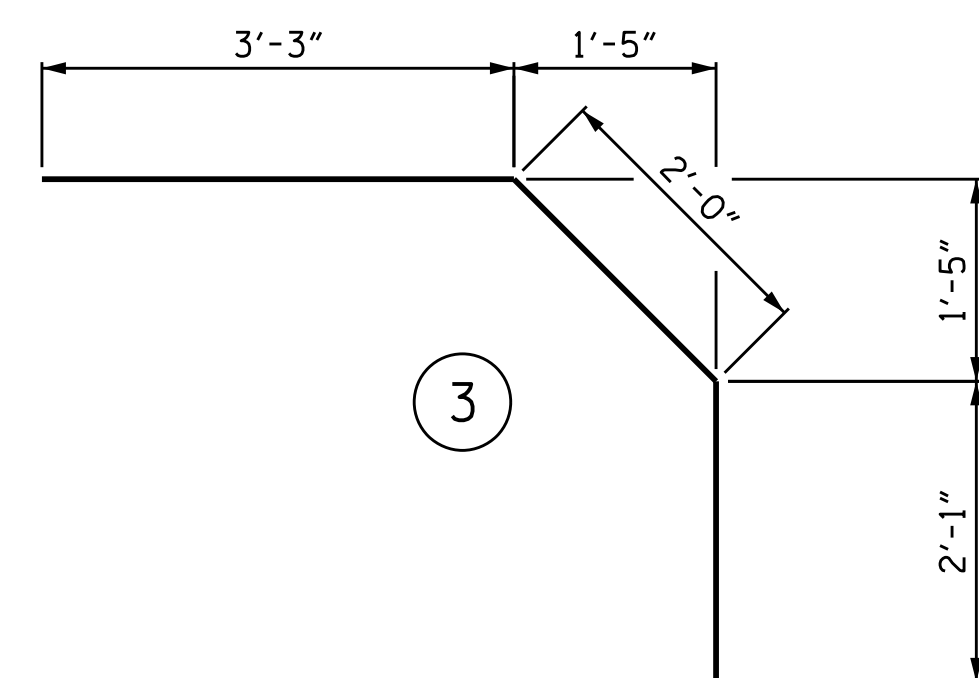
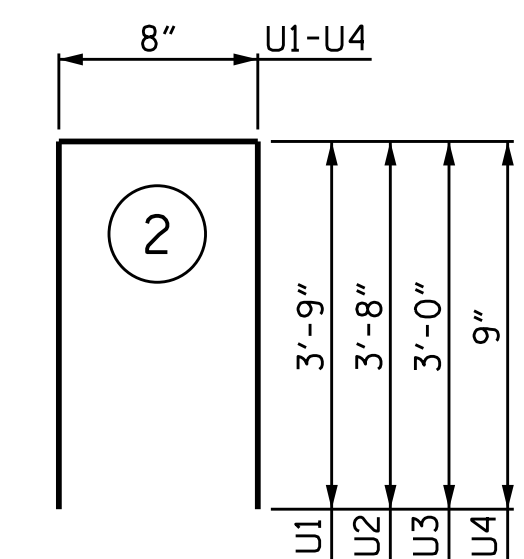
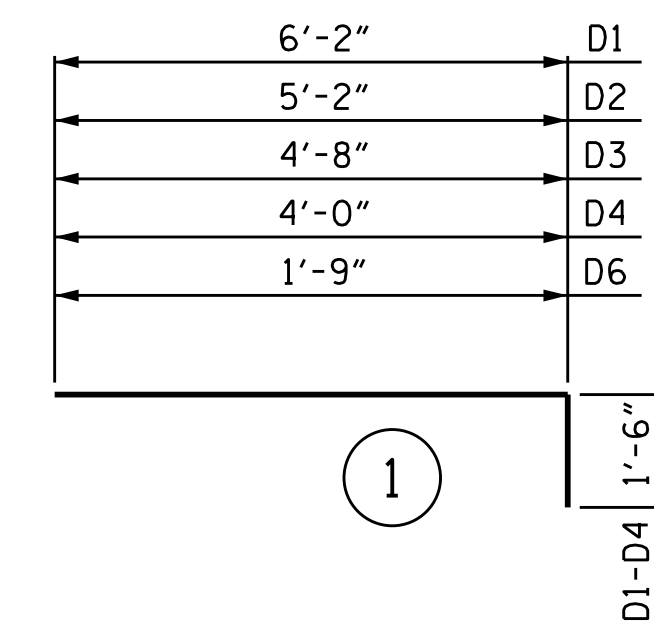

ALL BAR DIMENSIONS ARE OUT TO OUT.

PROJECT REFERENCE NO.	SHEET NO.
15614J075010	2D-7

BILL OF MATERIAL

BAR	NUMBER	SIZE	TYPE	LENGTH	WEIGHT
A1	46	#5	STR	11'-8"	560
A2	6	#5	STR	7'-4"	46
A3	8	#5	STR	2'-0"	17
A4	22	#5	STR	4'-1"	94
A5	6	#5	STR	8'-4"	52
A6	6	#5	STR	7'-5"	46
B1	76	#5	STR	7'-8"	608
B2	8	#5	STR	4'-5"	37
B3	16	#5	STR	2'-5"	40
B4	8	#5	STR	3'-1"	26
C1	60	#5	STR	4'-10"	302
C2	52	#5	STR	6'-6"	353
D1	2	#4	1	7'-8"	10
D2	6	#4	1	6'-8"	27
D3	2	#4	1	6'-2"	8
D4	2	#4	1	5'-6"	7
D5	2	#4	3	7'-4"	10
D6	14	#4	1	3'-6"	33
E1	16	#5	STR	3'-10"	64
E2	16	#5	STR	4'-5"	74
E3	16	#5	STR	5'-1"	85
E4	16	#5	STR	3'-0"	50
J1	96	#4	4	4'-5"	283
U1	5	#4	2	8'-2"	28
U2	1	#4	2	8'-0"	5
U3	1	#4	2	6'-8"	4
U4	2	#4	2	2'-2"	3
REINFORCING STEEL				2872 LBS.	
CLASS B CONCRETE				14.0 C.Y.	

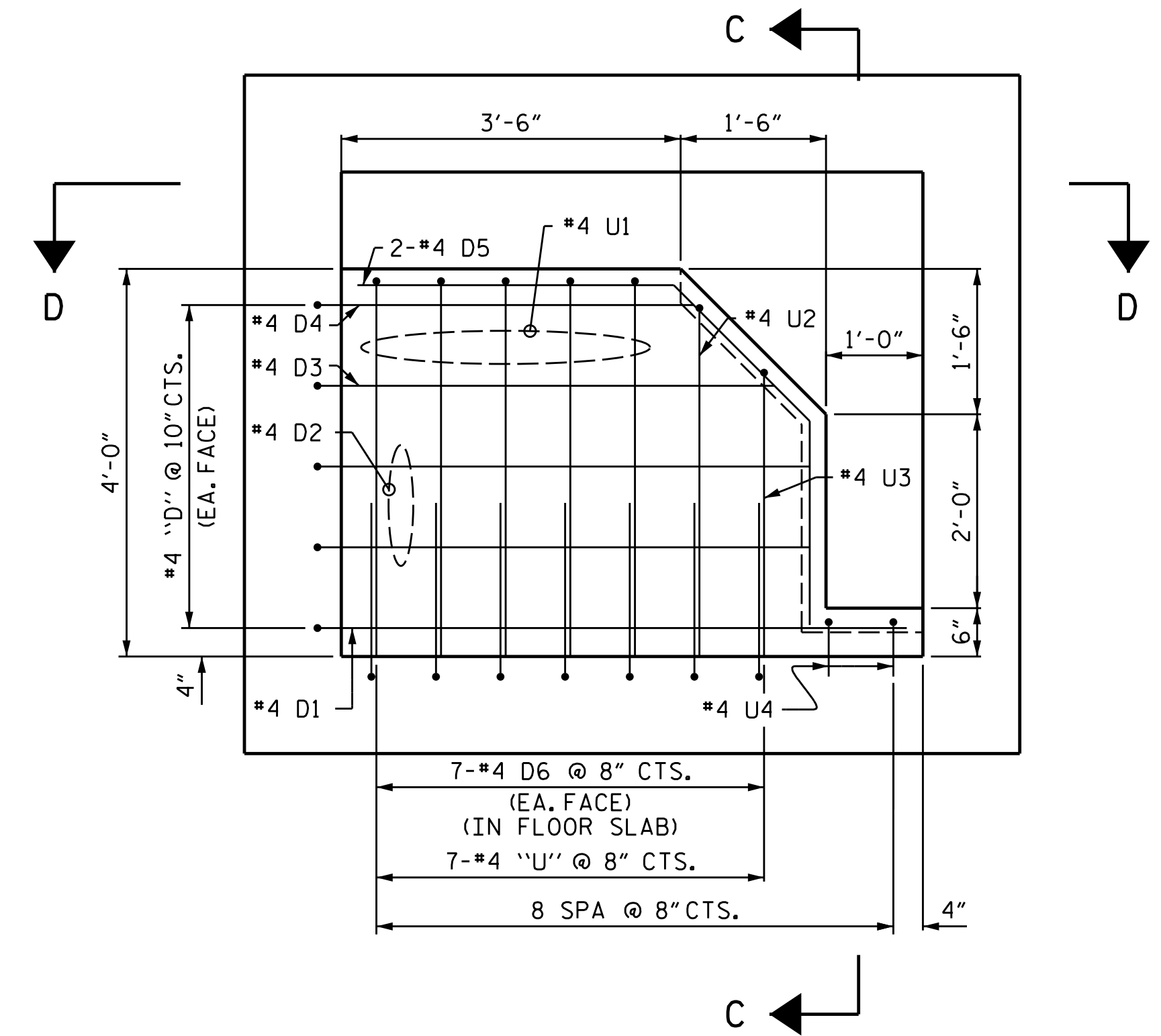
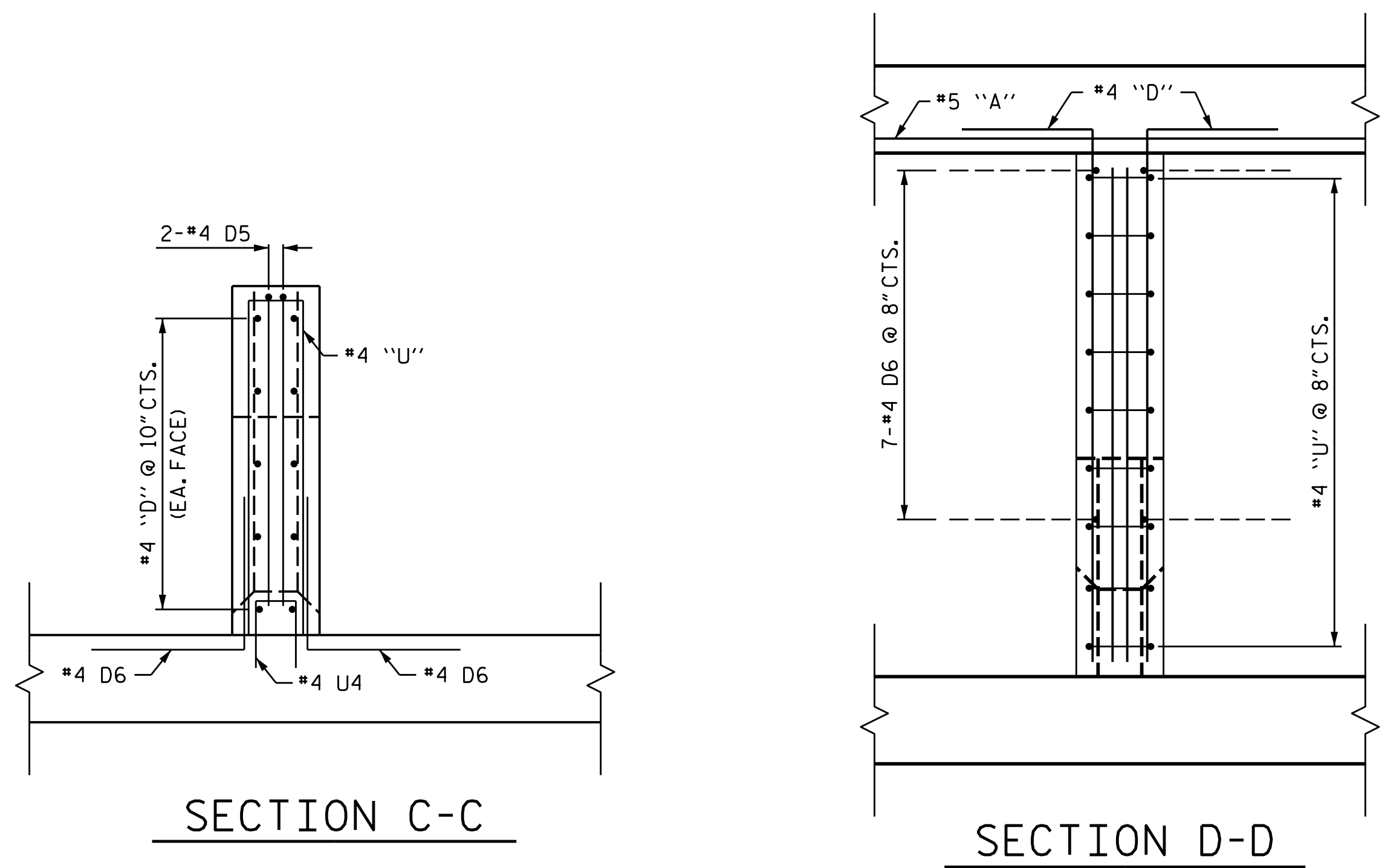

SPLITTER WALL DETAILS

#4 U4 BARS MAY BE PLACED INTO GREEN CONCRETE.

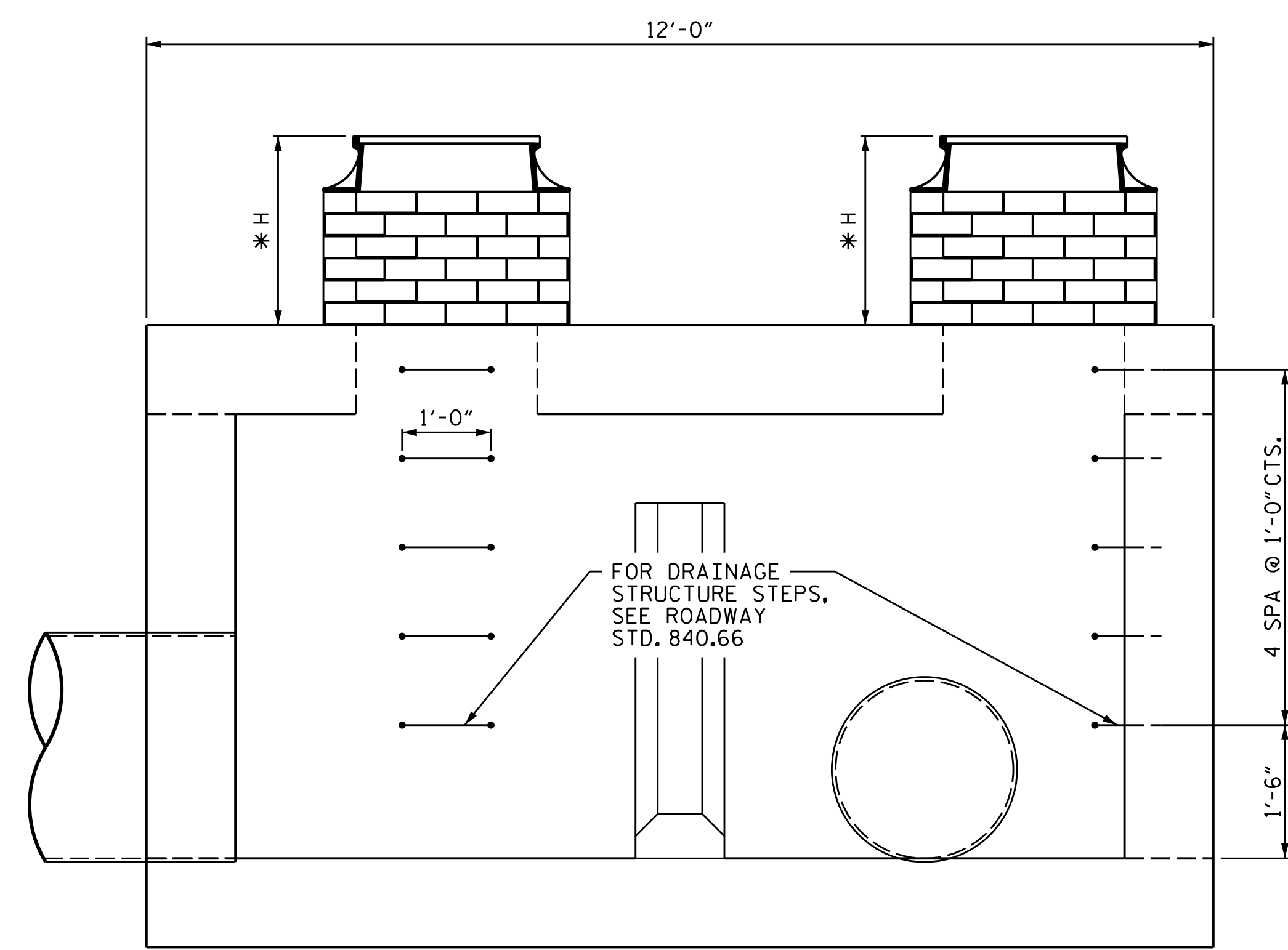

MANHOLE STEP DETAILS

* H TO BE DETERMINED BY CONTRACTOR TO ENSURE MANHOLE COVER WILL BE AT FINISHED GRADE.

NOTES

- DIMENSIONS MAY BE FIELD ADJUSTED AS DIRECTED BY THE ENGINEER.
- CHAMFER ALL EXPOSED CORNERS 1".
- CORRUGATED STEEL PIPES SHALL BE LOCATED BY THE ENGINEER.

DOCUMENT NOT CONSIDERED FINAL UNLESS ALL SIGNATURES COMPLETED

TGS ENGINEERS
706 HILLSBOROUGH STREET
SUITE 200
RALEIGH, NC 27603
PH (919) 773-8887
CORP. LICENSE NO.: C-0275

Professional Engineer Seal: Marshall G. Chen, P.E., License No. 58002344003, Seal 20125, dated 5/12/2021.

SPLITTER BOX

DRAWN BY : STM DATE : 02/21
CHECKED BY : MGC DATE : 03/21

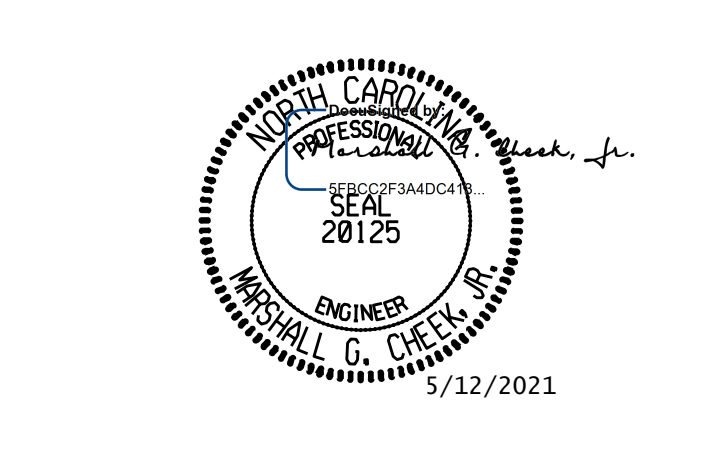

DOCUMENT NOT CONSIDERED FINAL
UNLESS ALL SIGNATURES COMPLETED

TGS ENGINEERS
706 HILLSBOROUGH STREET
SUITE 200
RALEIGH, NC 27603
PH (919) 773-8887
CORP. LICENSE NO.: C-0275

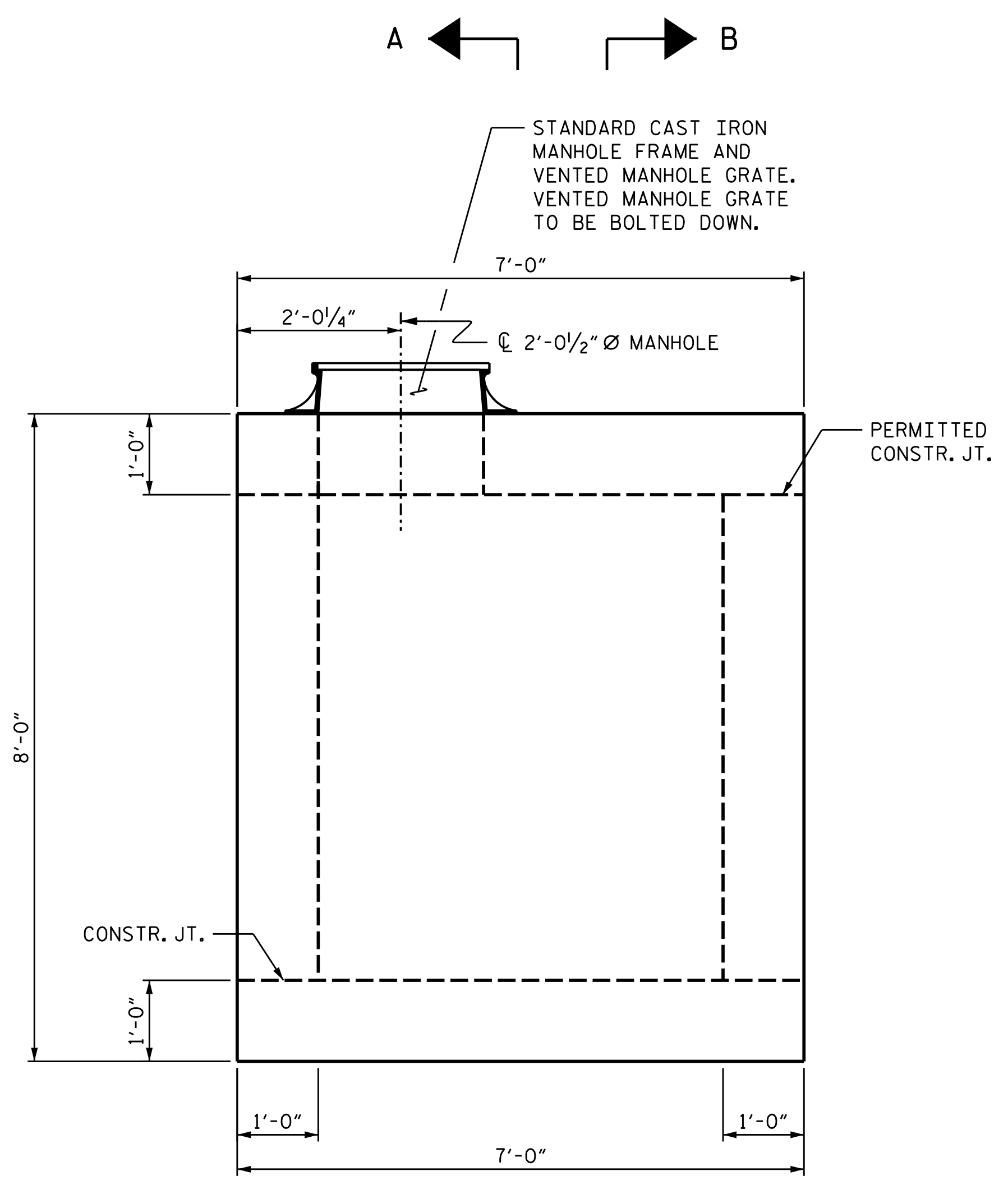

END ELEVATION
FOR SECTION A-A & B-B, SEE SHEET 2 OF 3.

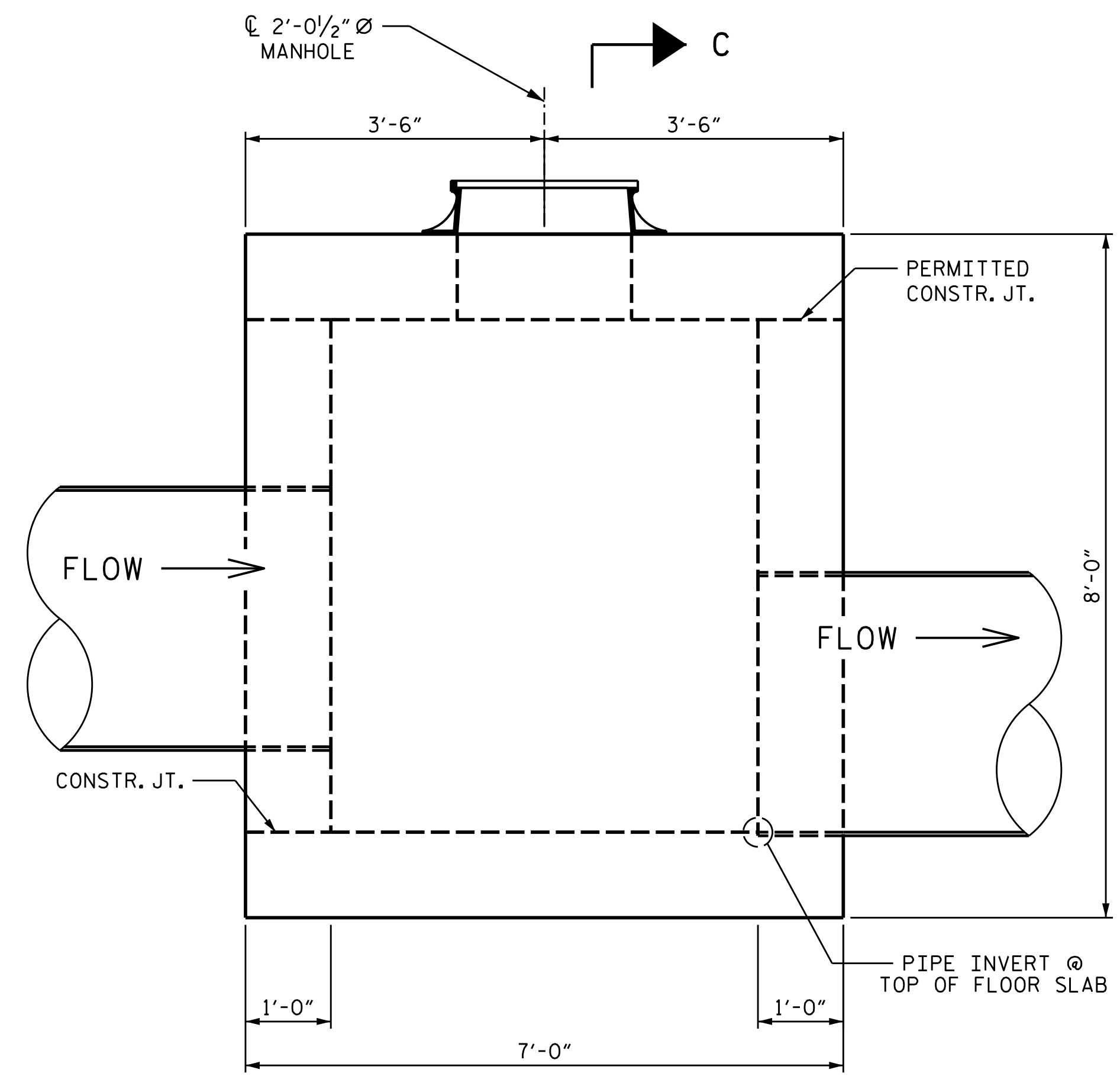

SIDE ELEVATION
FOR SECTION C-C, SEE SHEET 2 OF 3.

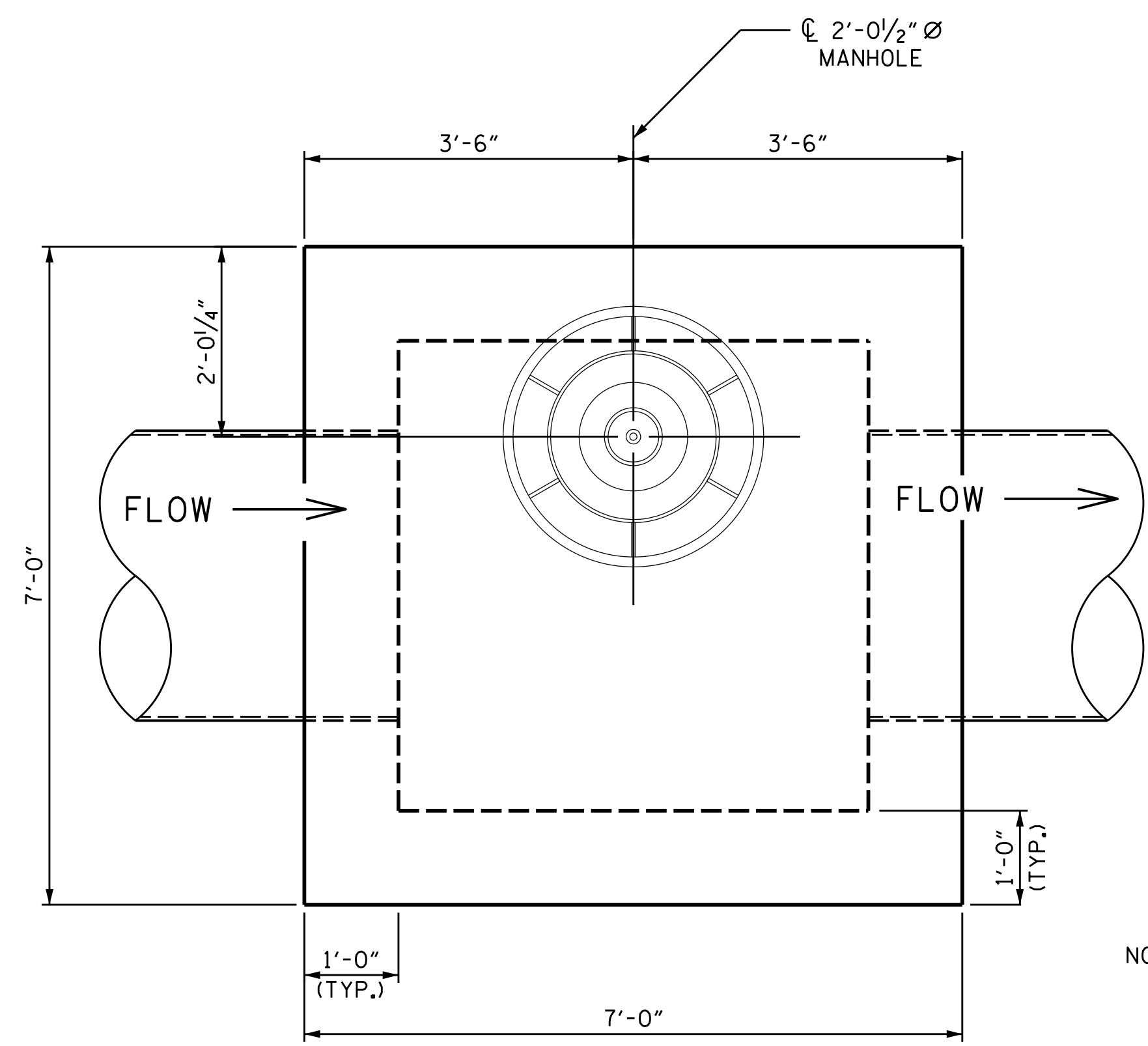

PLAN VIEW

NOTE: PLAN VIEW TYPICAL FOR ALL SPECIAL DESIGN JUNCTION BOX LOCATIONS, EXCEPT STRUCTURE 0539. STRUCTURE 0539 HAS AN ADDITIONAL INLET PIPE.

SHEET 1 OF 3

STATE OF NORTH CAROLINA
DEPARTMENT OF TRANSPORTATION
RALEIGH

**SPECIAL DESIGN
JUNCTION BOX**

DRAWN BY : STM DATE : 03/21
CHECKED BY : MGC DATE : 03/21

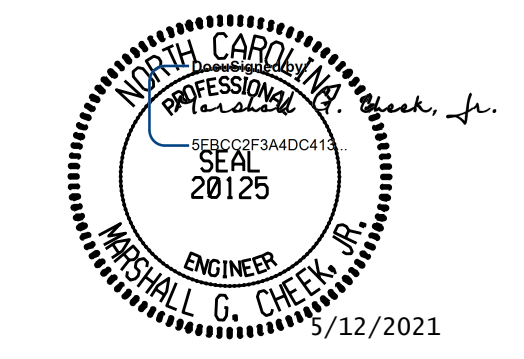

DOCUMENT NOT CONSIDERED FINAL
UNLESS ALL SIGNATURES COMPLETED

TGS ENGINEERS
706 HILLSBOROUGH STREET
SUITE 200
RALEIGH, NC 27603
PH (919) 773-8887
CORP. LICENSE NO.: C-0275

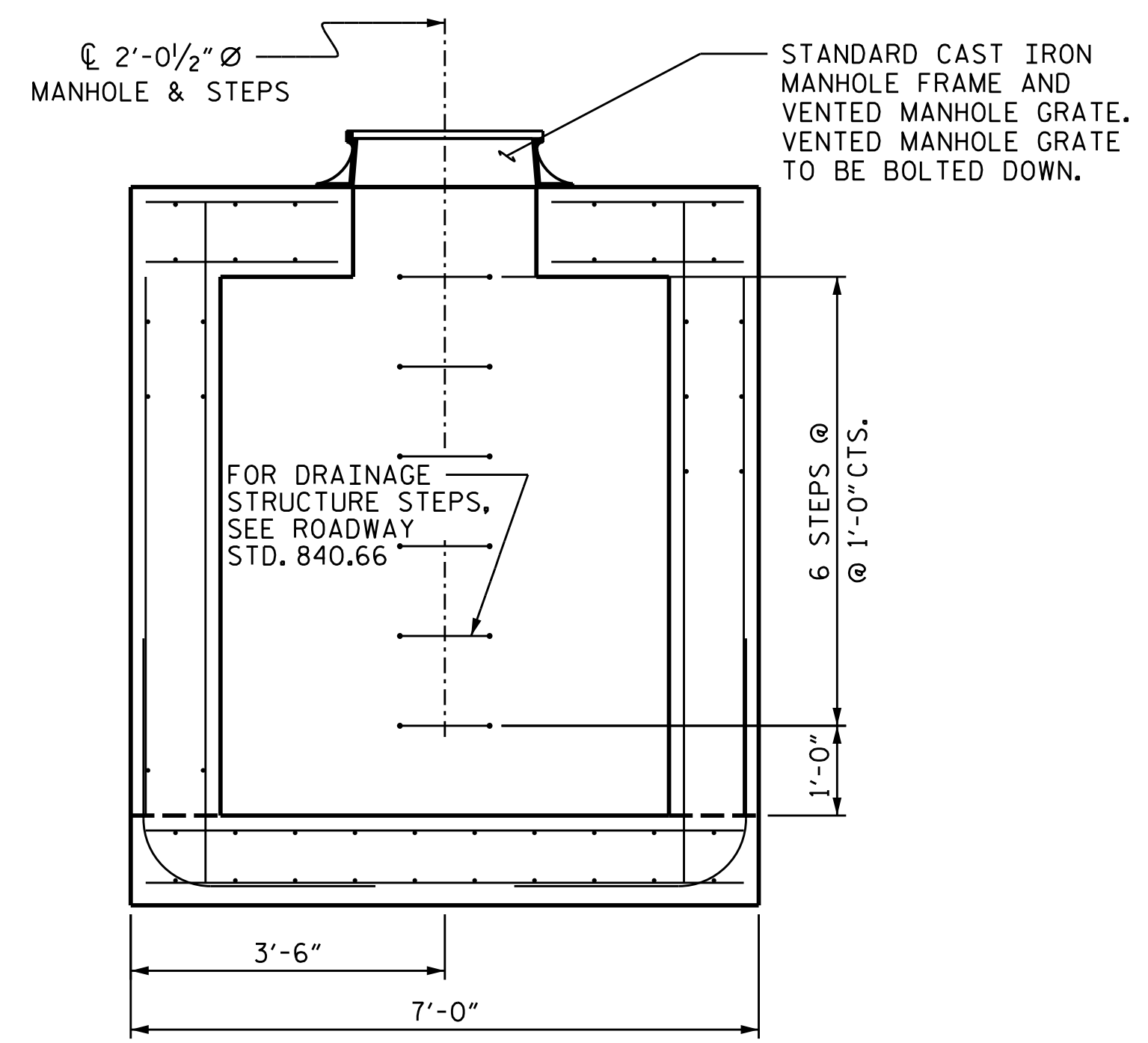

SECTION A-A

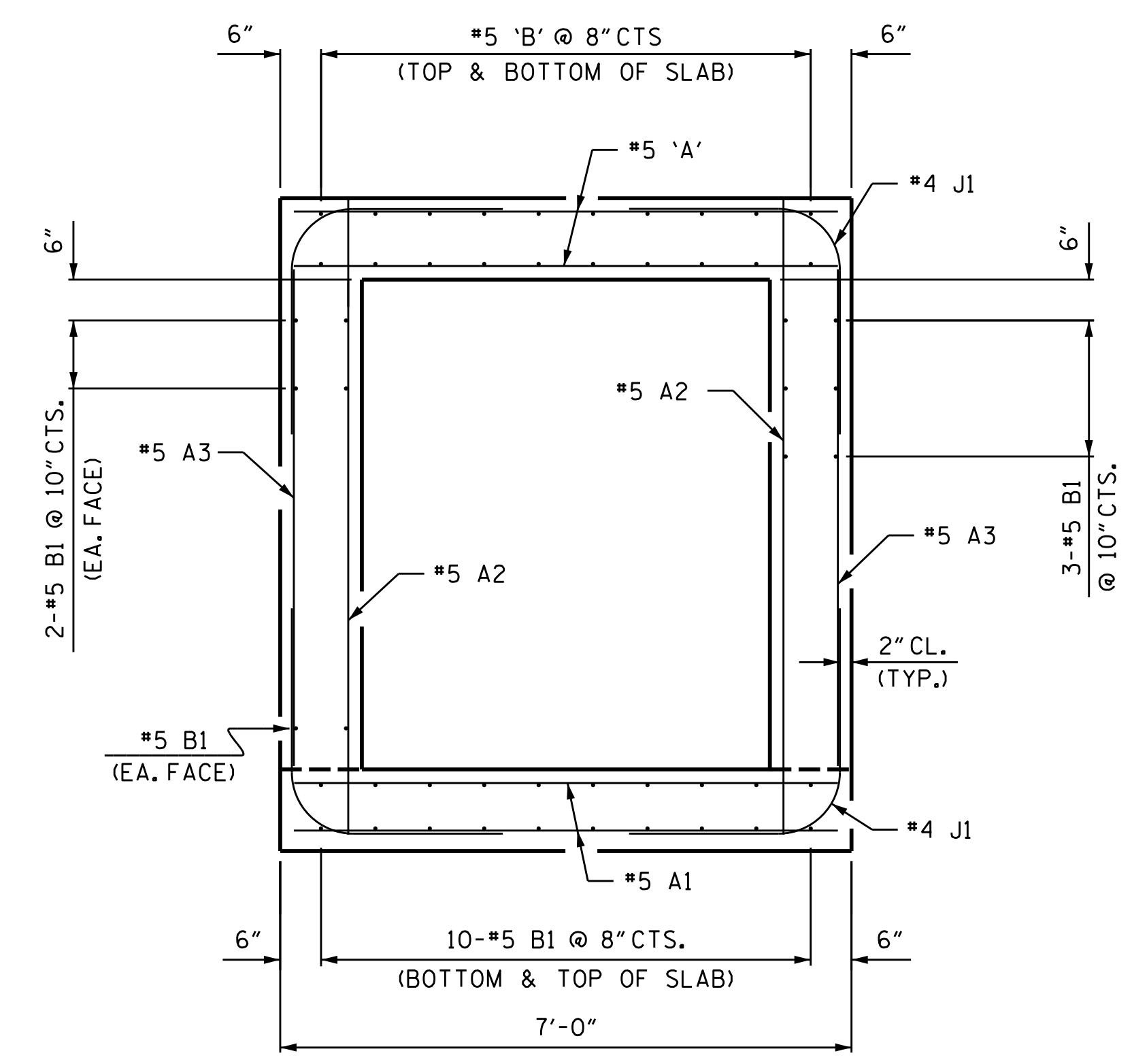

SECTION B-B

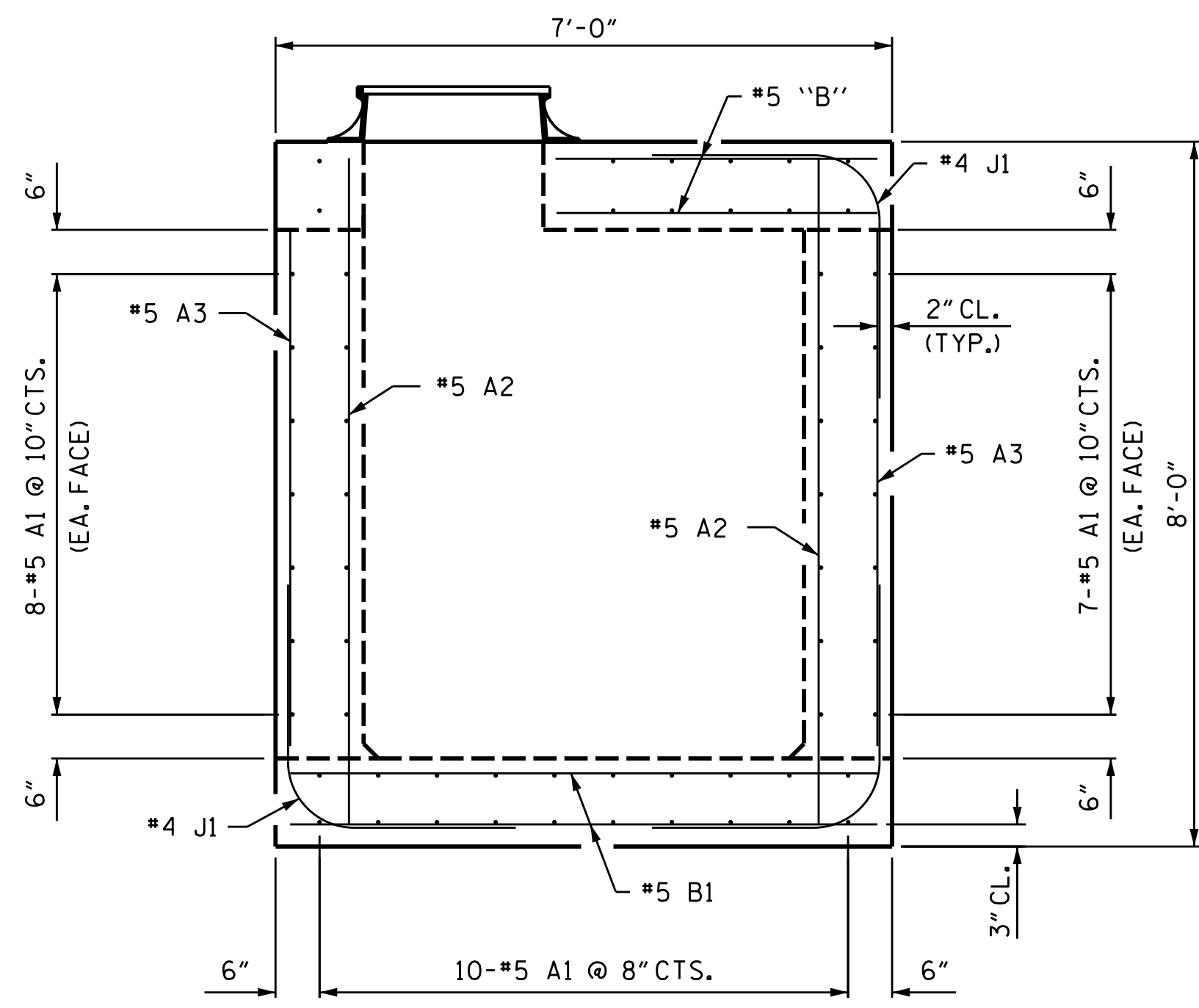

SECTION C-C

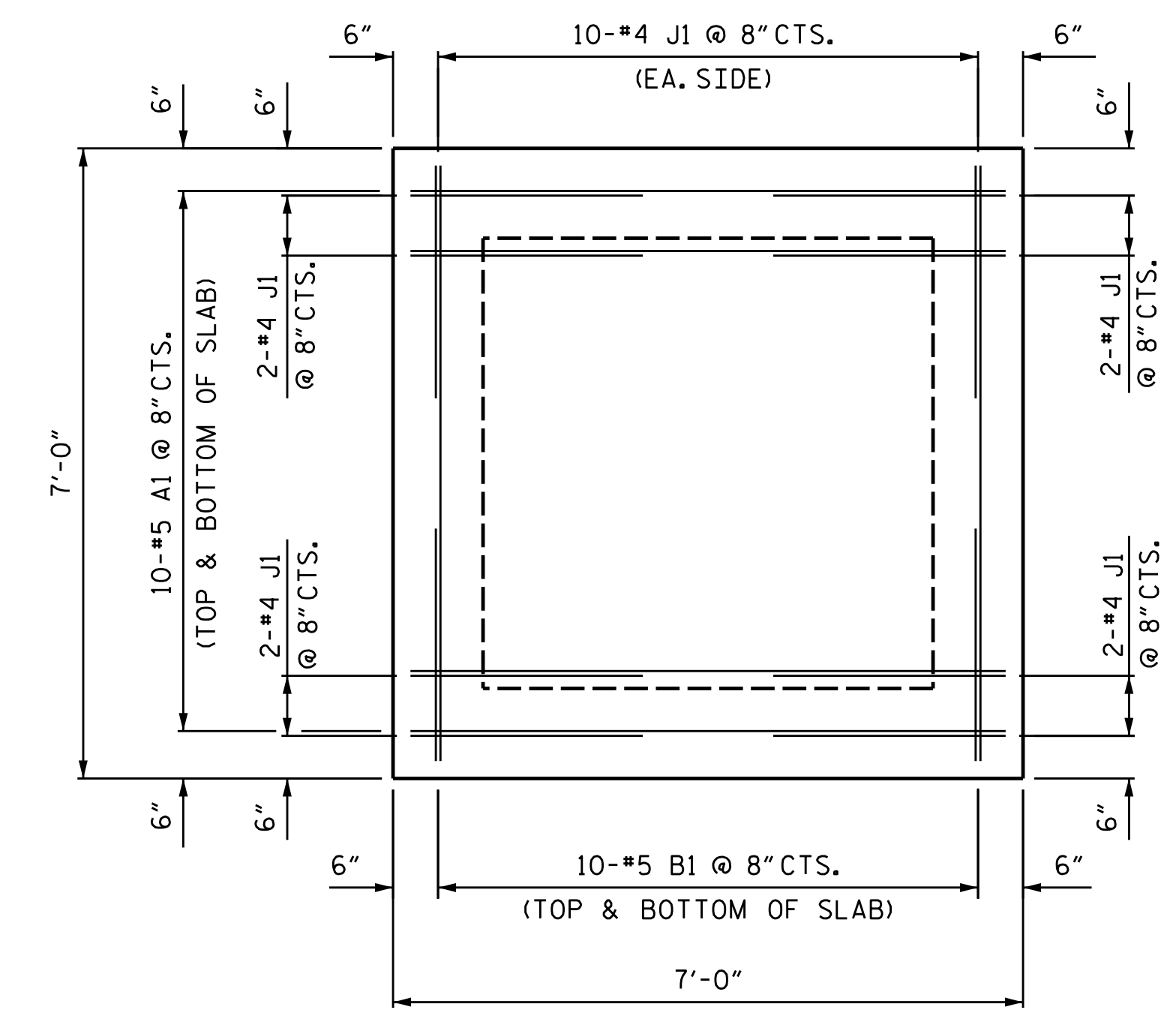

FLOOR SLAB

SHEET 2 OF 3

STATE OF NORTH CAROLINA
DEPARTMENT OF TRANSPORTATION
RALEIGH

SPECIAL DESIGN
JUNCTION BOX

DRAWN BY : STM DATE : 03/21
CHECKED BY : MGC DATE : 03/21

BAR TYPES

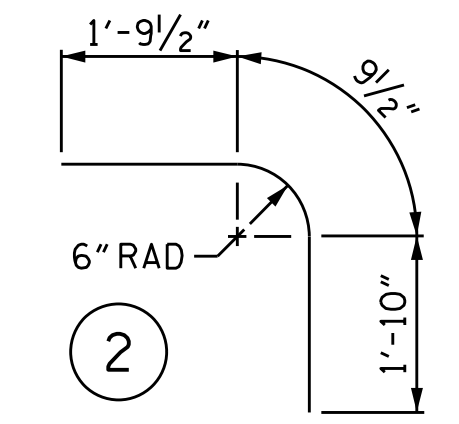

ALL BAR DIMENSIONS ARE OUT TO OUT.

PROJECT REFERENCE NO.	SHEET NO.
15614J075010	2D-10

BILL OF MATERIAL					
BAR	NUMBER	SIZE	TYPE	LENGTH	WEIGHT
A1	60	#5	STR	6'-6"	407
A2	32	#5	STR	7'-7"	253
A3	40	#5	STR	6'-0"	250
A4	16	#5	STR	2'-2"	36
B1	44	#5	STR	6'-6"	298
B2	8	#5	STR	2'-2"	18
C1	12	#6	STR	4'-11"	89
C2	8	#6	STR	2'-10"	34
J1	58	#4	2	4'-5"	171
REINFORCING STEEL				1556 LBS.	
CLASS B CONCRETE				9.0 C.Y.	

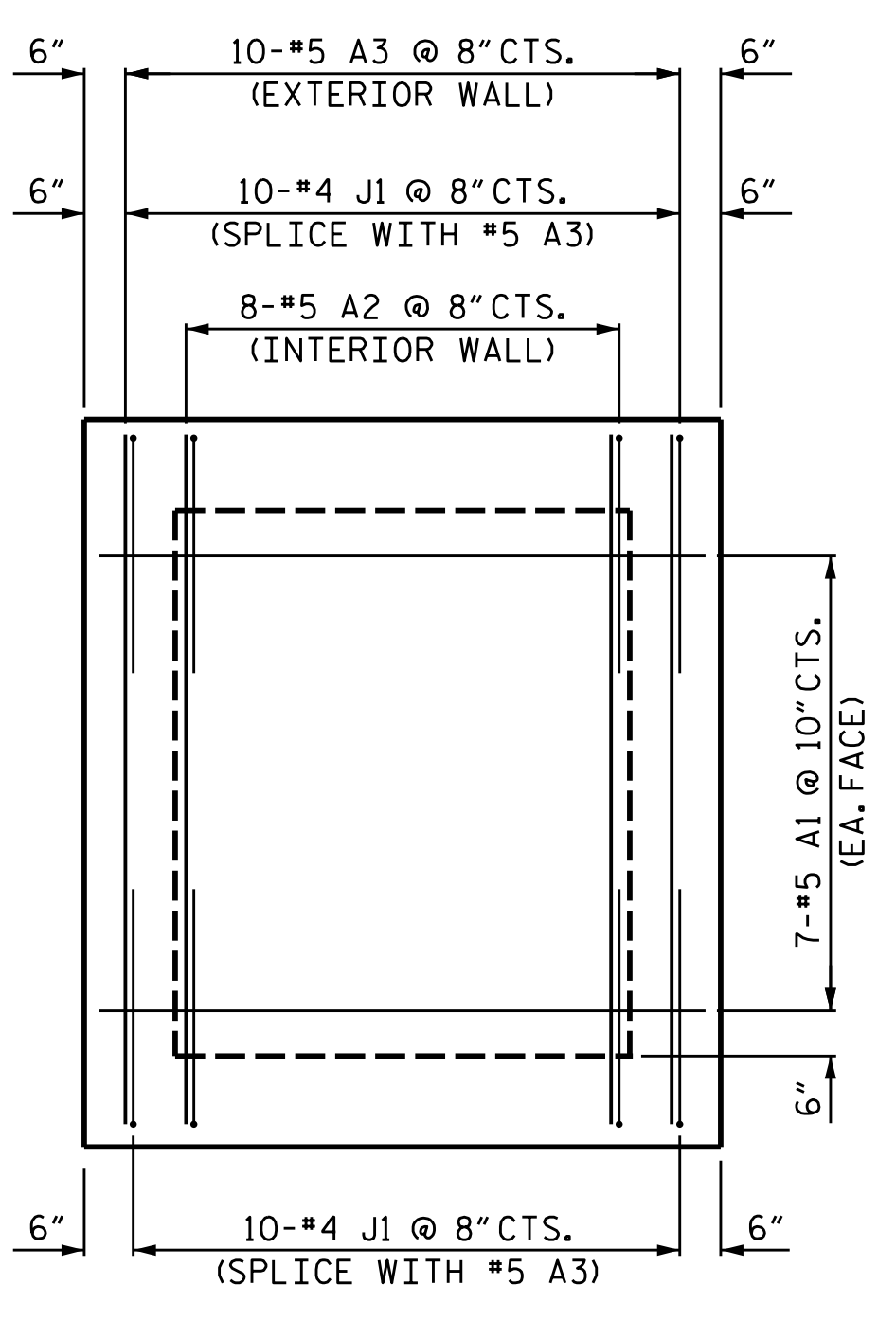

VIEW Z-Z

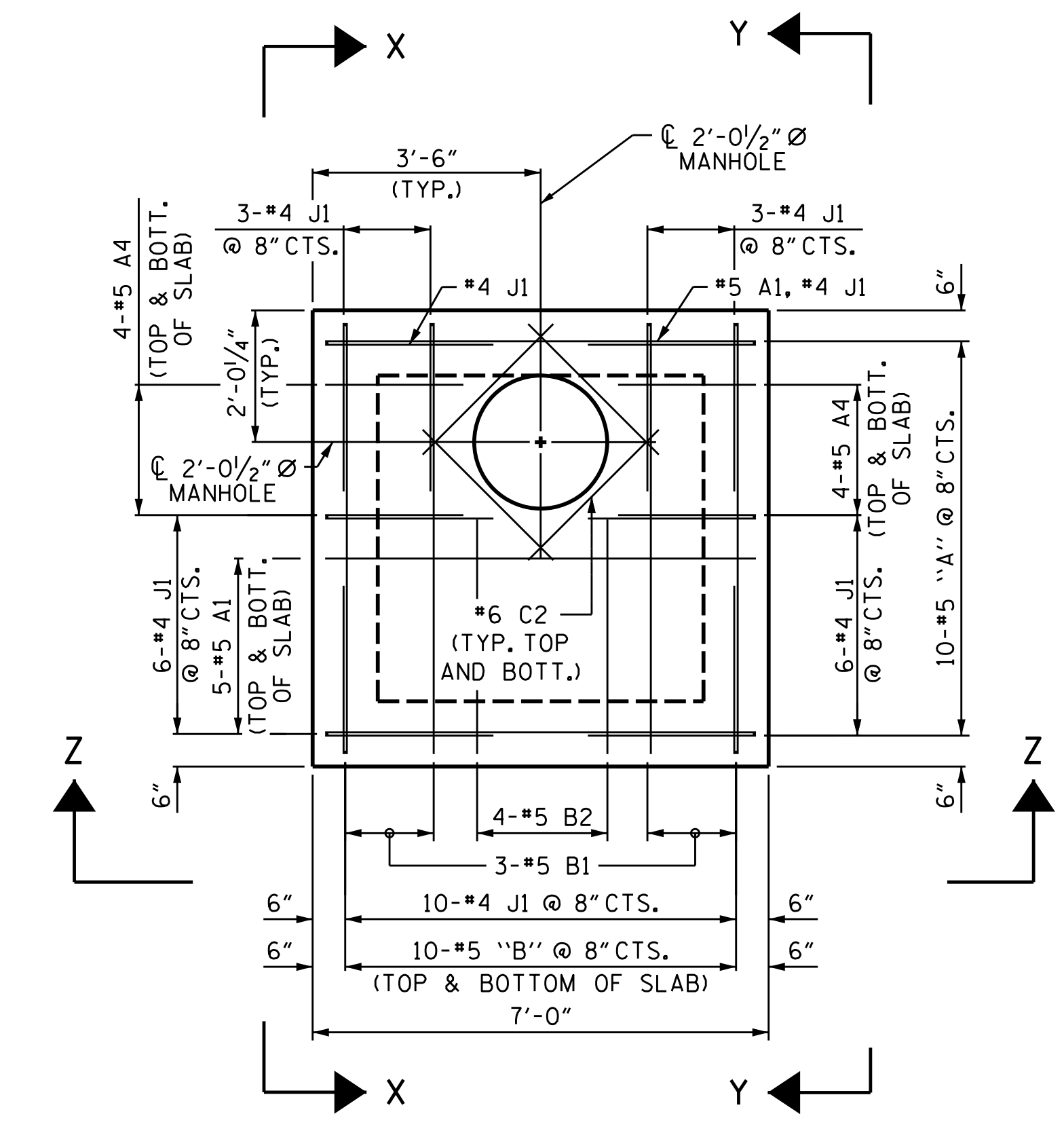

ROOF SLAB

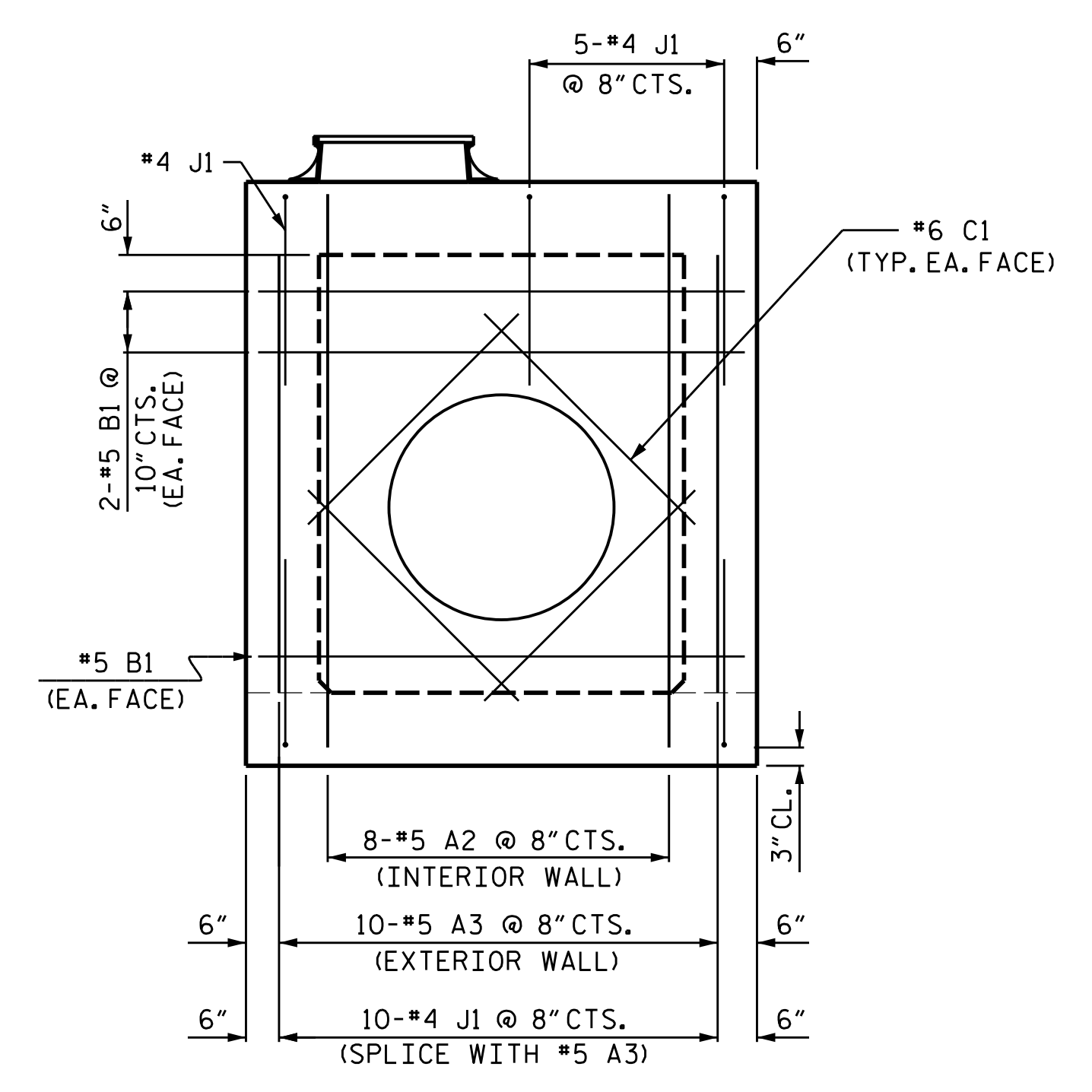

VIEW X-X

#5 A BARS SHALL BE FIELD CUT AS NECESSARY FOR INSTALLATION OF THE PIPE

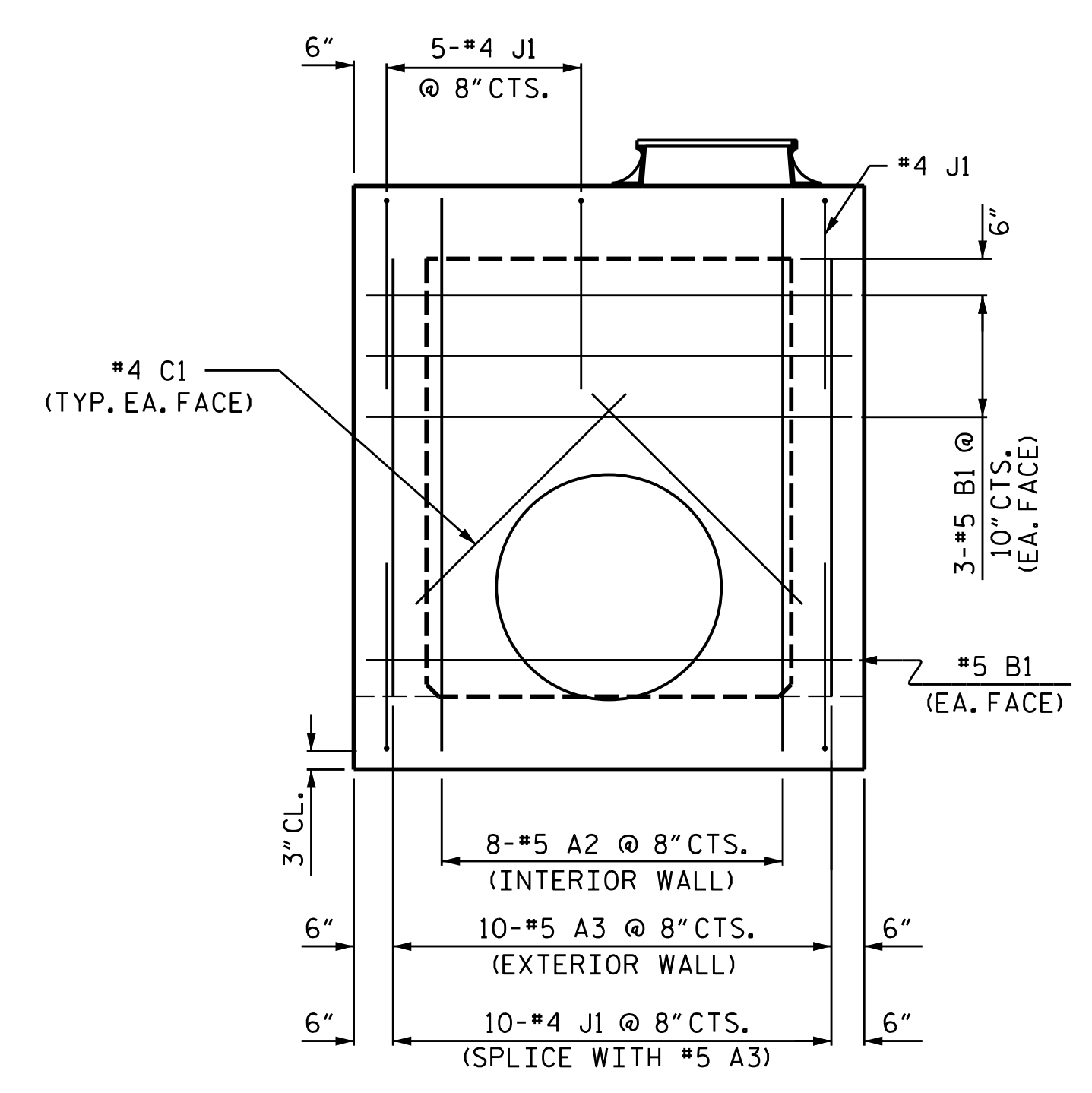

VIEW Y-Y

#5 A BARS SHALL BE FIELD CUT AS NECESSARY FOR INSTALLATION OF THE PIPE

NOTES

- DIMENSIONS MAY BE FIELD ADJUSTED AS DIRECTED BY THE ENGINEER.
- CHAMFER ALL EXPOSED CORNERS 1".
- CORRUGATED STEEL PIPES SHALL BE LOCATED BY THE ENGINEER.
- FOR MANHOLE FRAME AND VENTED MANHOLE GRATE, SEE SPECIAL PROVISIONS.
- STRUCTURE 0539 HAS AN ADDITIONAL INLET PIPE. REINFORCING STEEL IN WALL AT LOCATION OF PIPE SHALL BE FIELD CUT AS NECESSARY FOR THE INSTALLATION OF THE PIPE. PROVIDE ADDITIONAL #4 C1 BARS AROUND PIPE.

DOCUMENT NOT CONSIDERED FINAL UNLESS ALL SIGNATURES COMPLETED

TGS ENGINEERS
706 HILLSBOROUGH STREET
SUITE 200
RALEIGH, NC 27603
PH (919) 773-8887
CORP. LICENSE NO.: C-0275

SHEET 3 OF 3

STATE OF NORTH CAROLINA
DEPARTMENT OF TRANSPORTATION
RALEIGH

SPECIAL DESIGN
JUNCTION BOX

DRAWN BY : STM DATE : 03/21
CHECKED BY : MGC DATE : 03/21

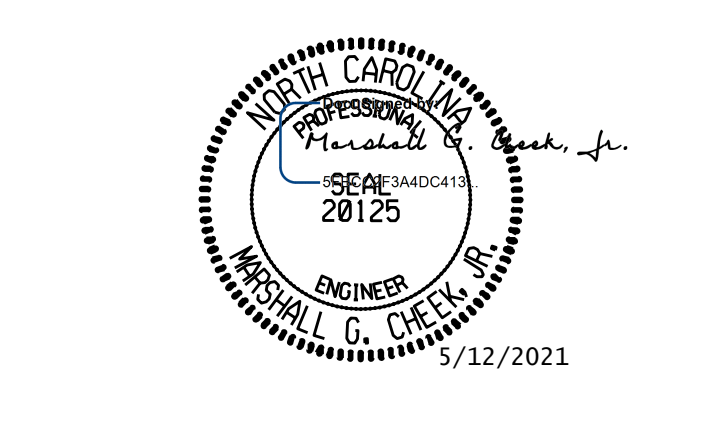

DOCUMENT NOT CONSIDERED FINAL
UNLESS ALL SIGNATURES COMPLETED

IGS ENGINEERS
706 HILLSBOROUGH STREET
SUITE 200
RALEIGH, NC 27603
PH (919) 773-8887
CORP. LICENSE NO.: C-0275

NOTES

- MOUNTING PLATE SHALL BE AASHTO M270 GRADE 36.
- MOUNTING PLATE SURFACES SHALL BE SMOOTH AND STRAIGHT.
- ADHESIVELY ANCHORED BOLTS SHALL BE INSTALLED IN ACCORDANCE WITH THE MANUFACTURERS GUIDELINES.
- FOR SPECIAL DESIGN PIPE CONNECTION, SEE SPECIAL PROVISIONS.
- ADHESIVELY ANCHORED BOLTS SHALL BE LEVEL 1 FIELD TESTED AND THE YIELD LOAD OF THE 7/8" Ø BOLT SHALL BE 4 KIPS.

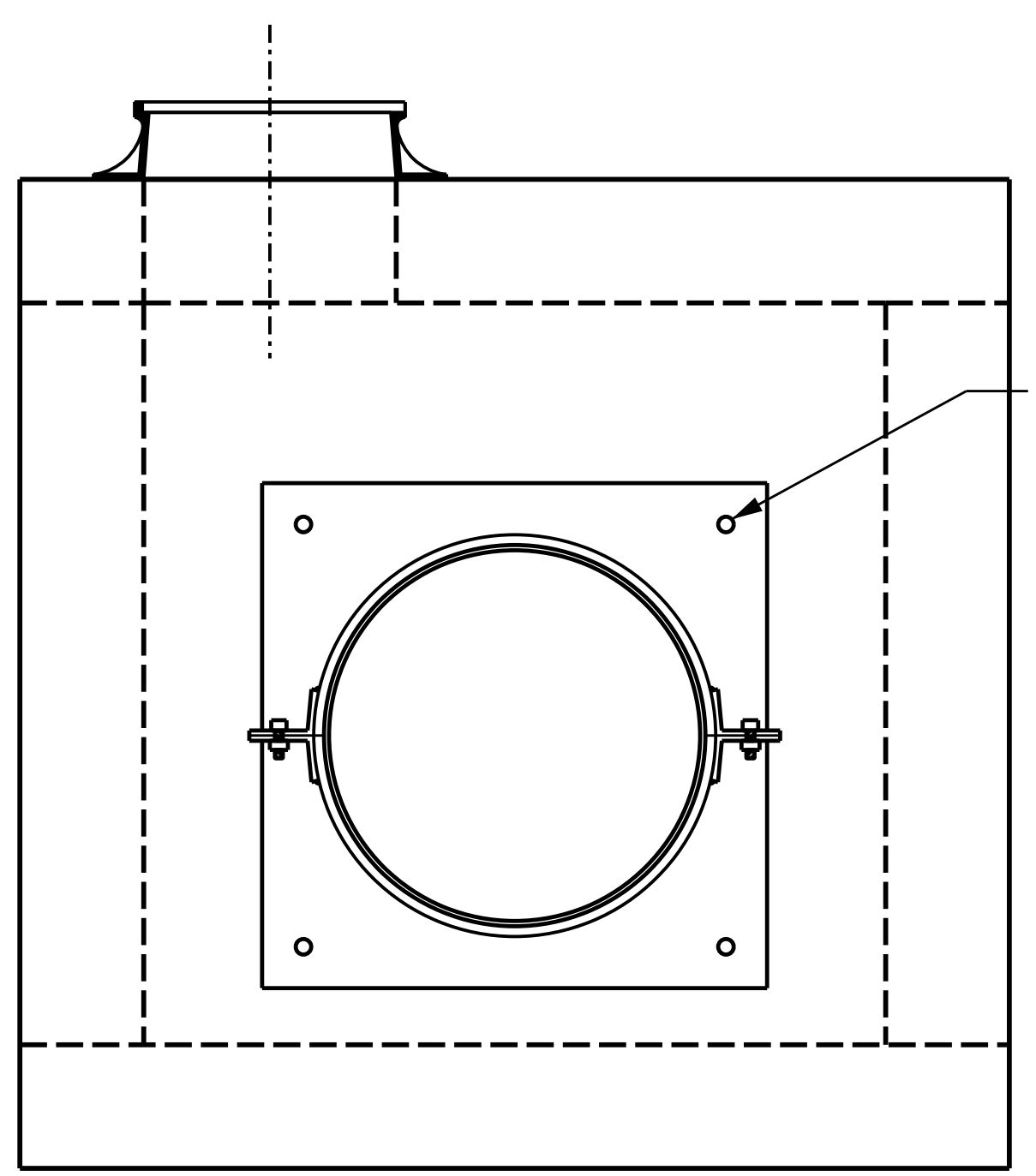

END ELEVATION

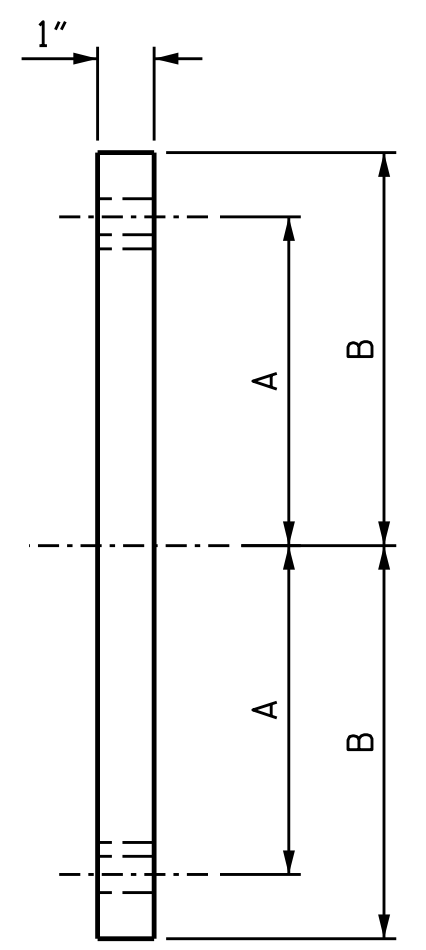

	18" CSP	24" CSP	30" CSP	36" CSP
DIM. A	12"	15"	18"	21"
DIM. B	15"	18"	21"	24"

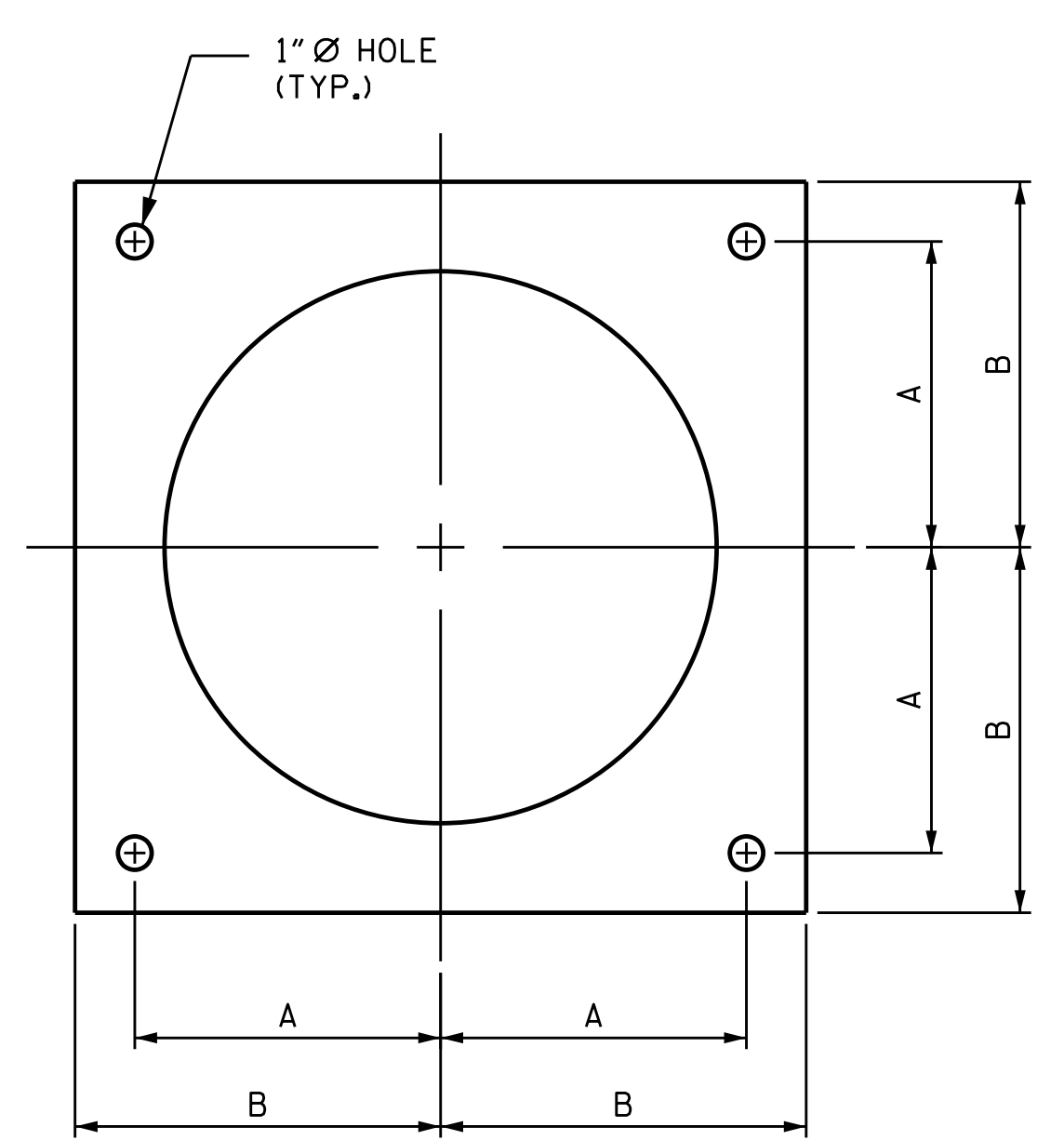

MOUNTING PLATE

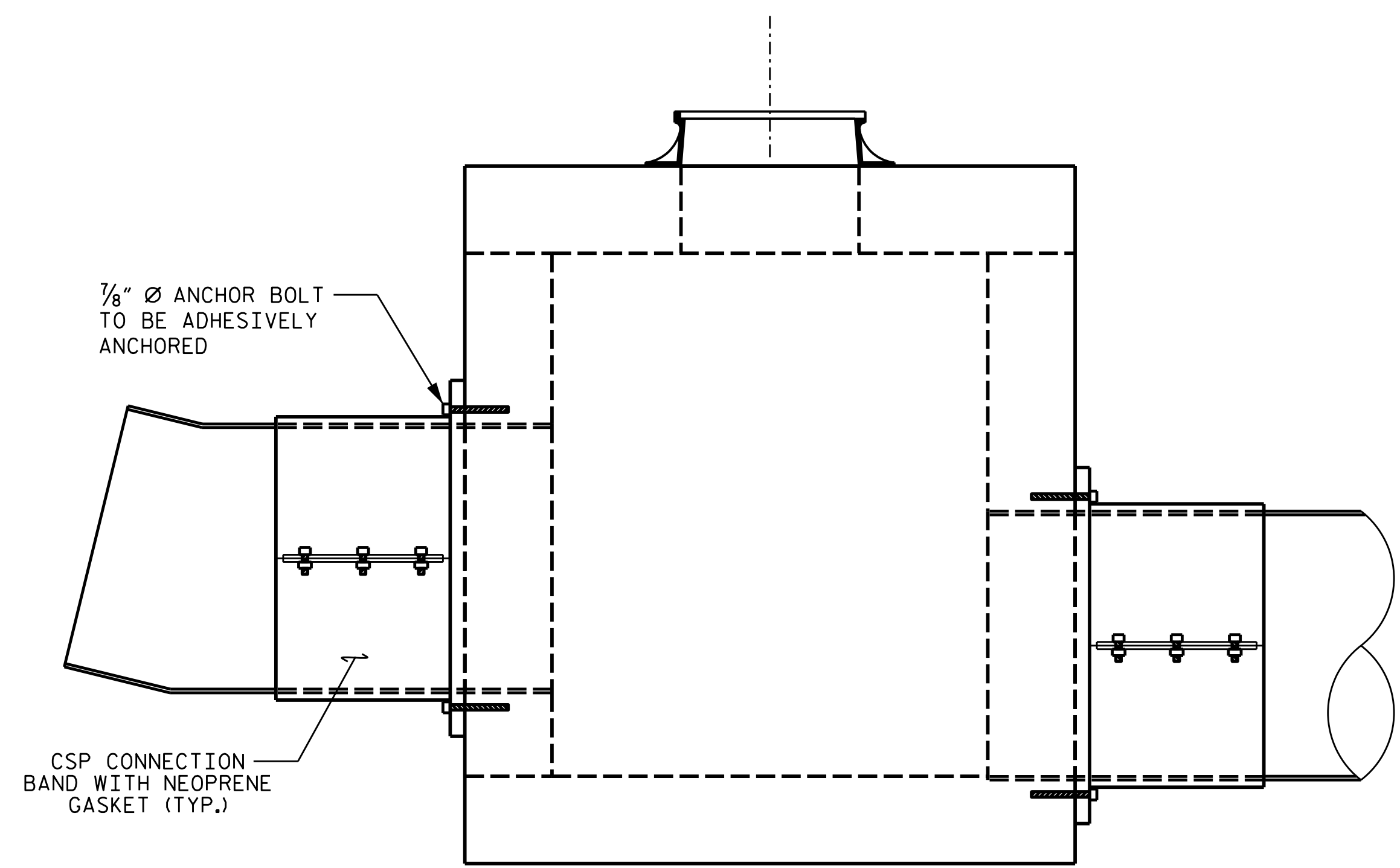

CSP CONNECTION BAND WITH NEOPRENE GASKET (TYP.)

SIDE ELEVATION

ELEVATION SHOWN FOR ILLUSTRATIVE PURPOSES, FOR LOCATIONS OF REQUIRED SPECIAL DESIGN PIPE CONNECTIONS, SEE DRAINAGE SUMMARY SHEETS.

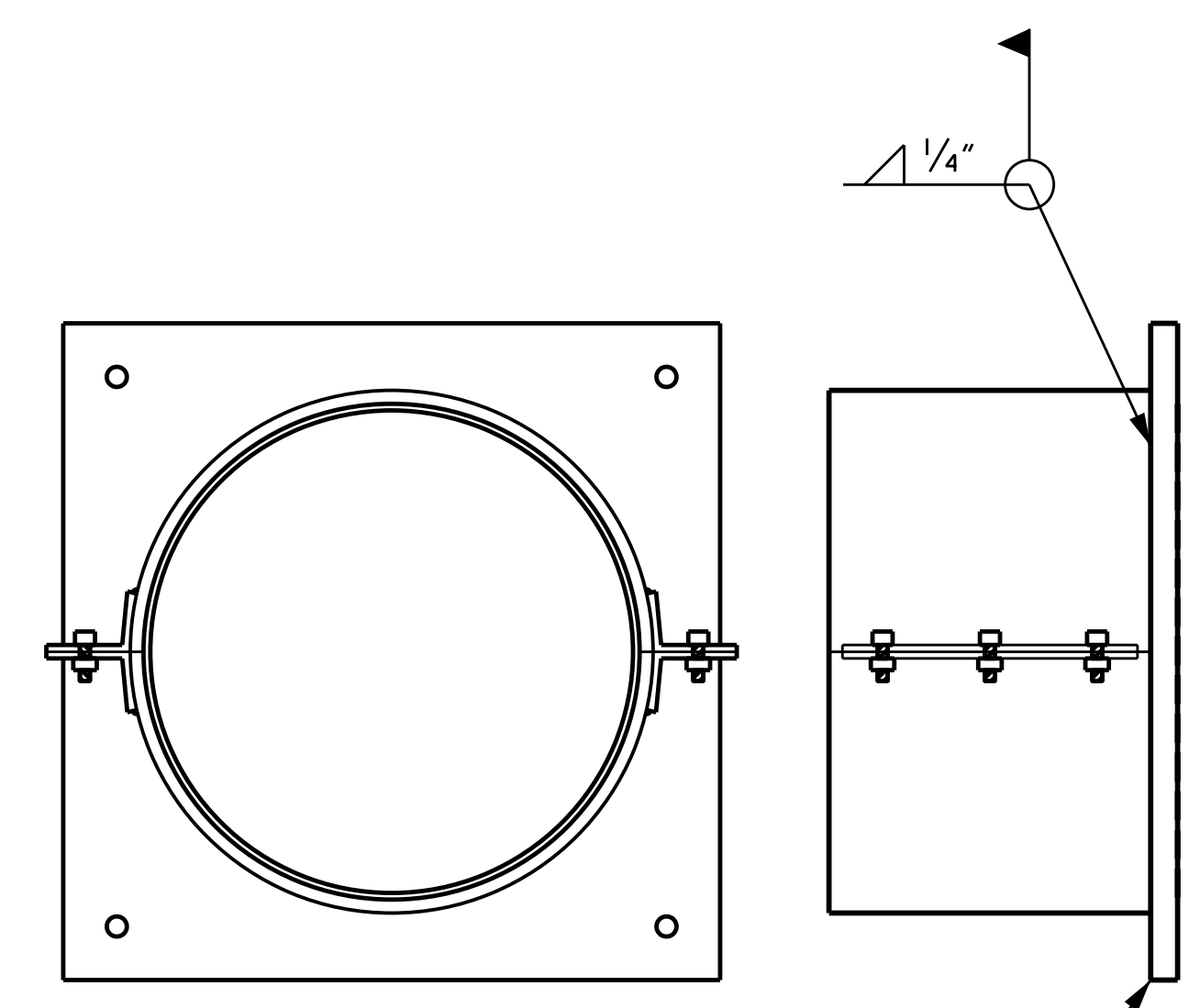

MOUNTING PLATE

CONNECTION BOND TO MOUNTING PLATE WELD DETAIL

SHEET 1 OF 1

STATE OF NORTH CAROLINA
DEPARTMENT OF TRANSPORTATION
RALEIGH

SPECIAL DESIGN PIPE CONNECTION

DRAWN BY : STM DATE : 03/21
CHECKED BY : MGC DATE : 03/21

01-MAR-2018 07:39 S:\Contracts\Special Details\Vericard\usr\details\stand\840d17 Extra Depth 2GI.dgn J:\over-ton AT_CSD-292595

STATE OF
NORTH CAROLINA
DEPT. OF TRANSPORTATION
DIVISION OF HIGHWAYS
RALEIGH, N.C.

ENGLISH DETAIL DRAWING FOR
CONCRETE MEDIAN DROP INLET TYPE 'A'
EXTRA DEPTH OVER 12' TO 25'
12" THRU 72" PIPE

SHEET 1 OF 2
840D17

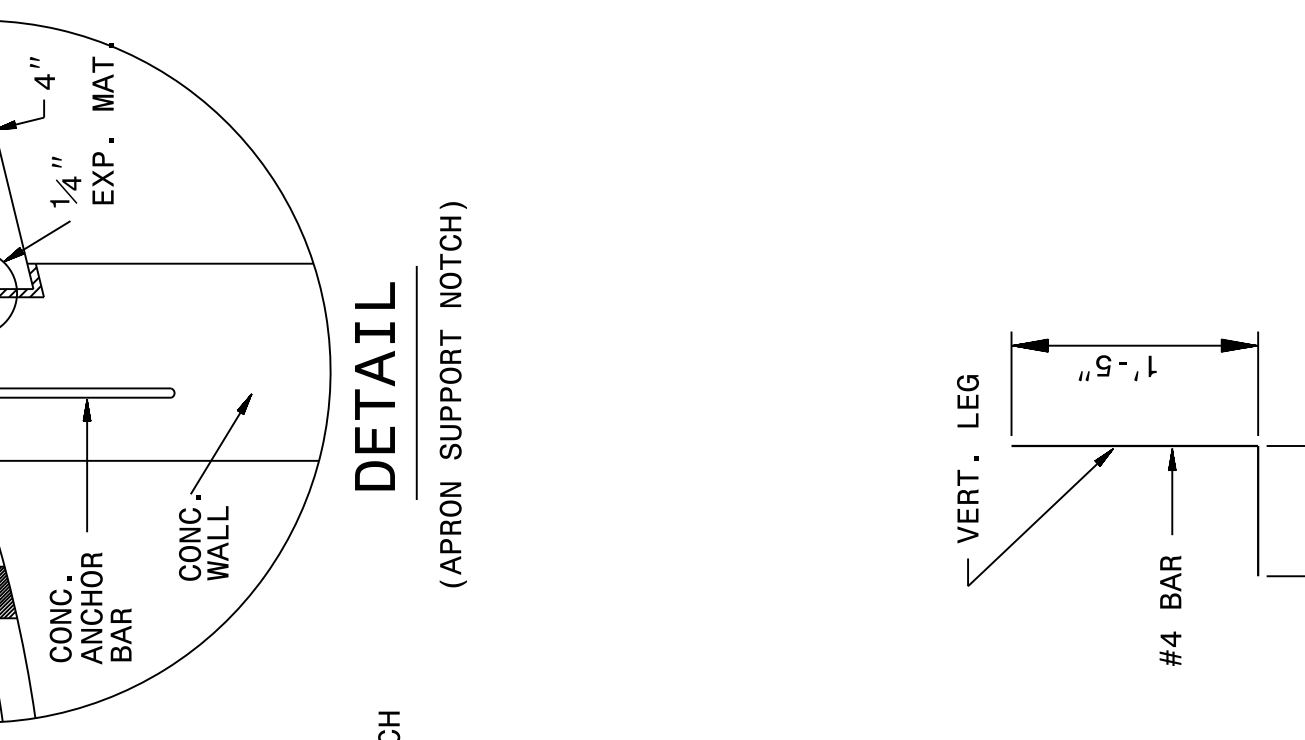
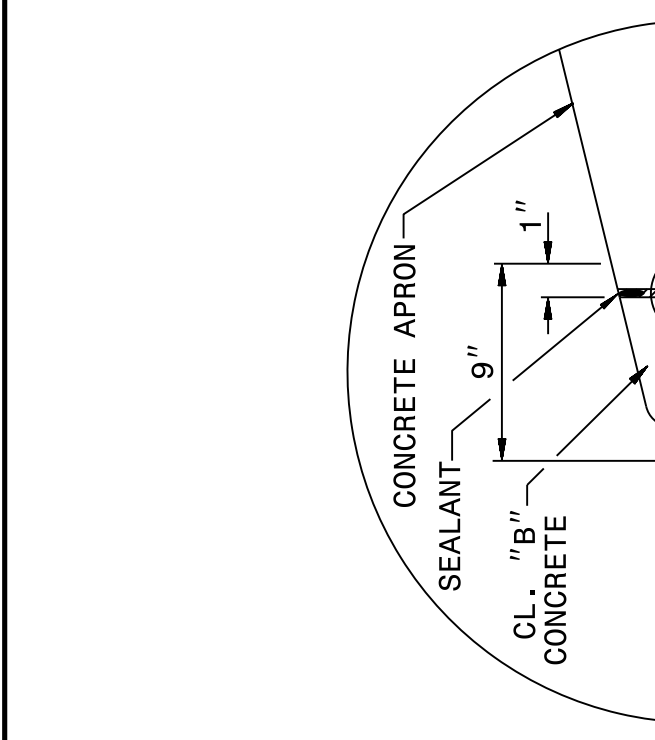
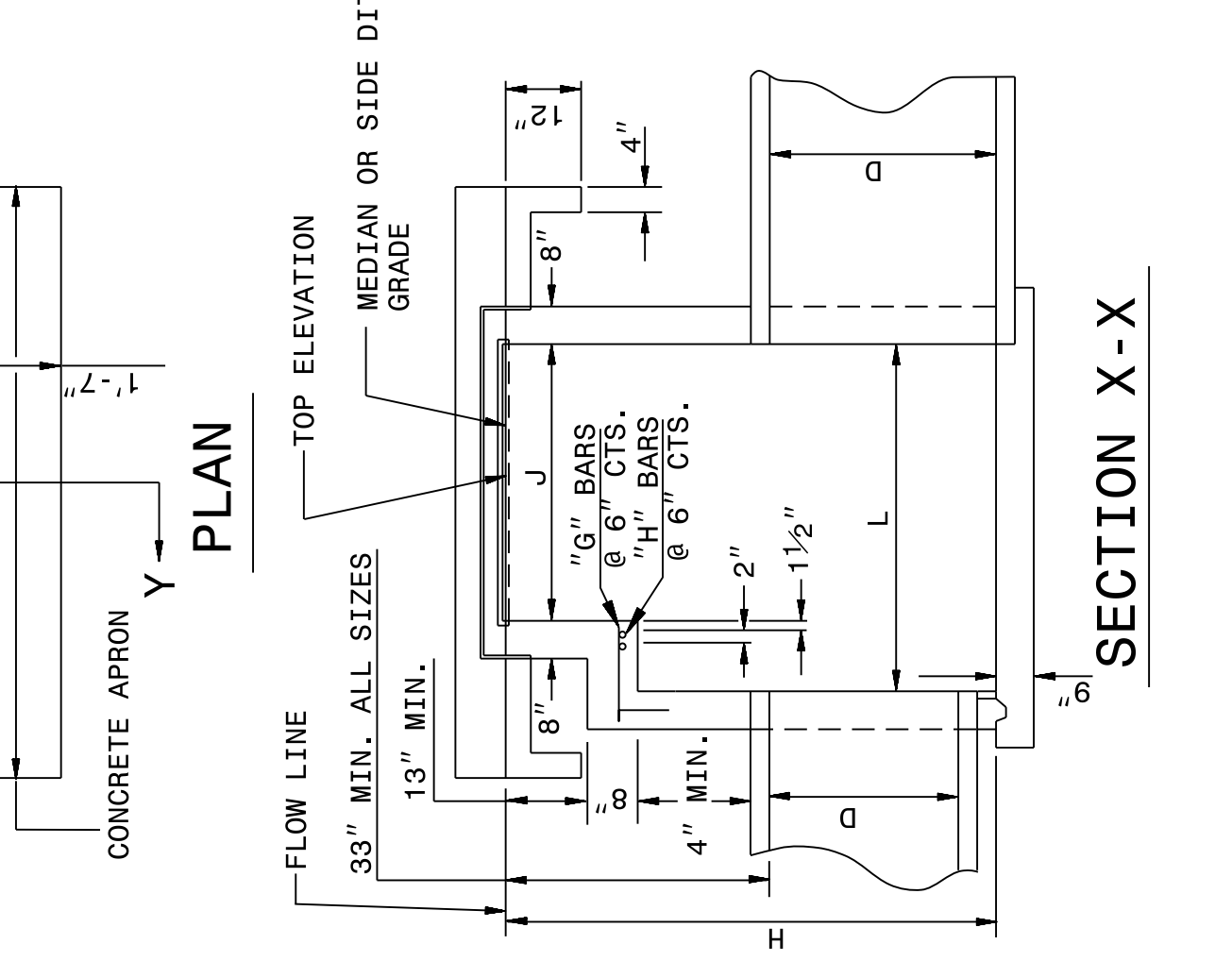
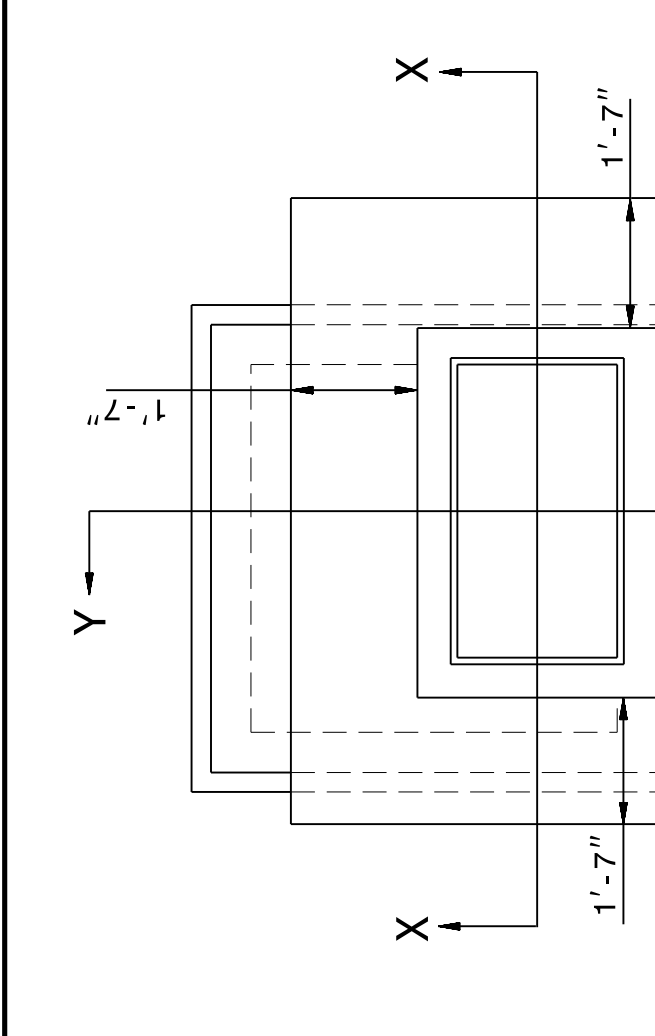

GENERAL NOTES:
USE CLASS "B" CONCRETE THROUGHOUT.
PROVIDE DROP INLETS WITH STEPS 12" ON CENTER. USE STEPS WHICH COMPLY WITH STD. DRAWING 840.66.
OPTIONAL CONSTRUCTION - MONOLITHIC POUR, 2" KEYWAY, OR #4 BAR DOWELS AT 12" CENTERS AS DIRECTED BY THE ENGINEER.
USE FORMS FOR THE CONSTRUCTION OF THE BOTTOM SLAB.
IF REINFORCED CONCRETE PIPE IS SET IN BOTTOM SLAB OF BOX, ADD TO SLAB AS SHOWN ON STD. NO. 840.00.
WHEN PAYMENT FOR THE DROP INLET IS MADE ON A PER EACH BASIS, THE CONCRETE APRON WILL BE CONSIDERED PART OF THE DROP INLET.
CONSTRUCT WITH PIPE CROWNS MATCHING.
USE STANDARD FRAMES AND GRATES 840.22 (SHOWN), 840.24 (SHOWN), 840.20, 840.29, AND 840.33.
SEE STANDARD DRAWING 840.25 FOR ATTACHMENT OF FRAMES AND GRATES NOT SHOWN.
CHAMFER ALL EXPOSED CORNERS 1".
DRAWING NOT TO SCALE.
MAX. DEPTH OF THIS STRUCTURE FROM TOP OF BOTTOM SLAB TO TOP ELEVATION IS 25 FEET.

ENGLISH DETAIL DRAWING FOR
CONCRETE MEDIAN DROP INLET TYPE 'A'
EXTRA DEPTH OVER 12' TO 25'
12" THRU 72" PIPE

SHEET 1 OF 2
840D17

STATE OF
NORTH CAROLINA
DEPT. OF TRANSPORTATION
DIVISION OF HIGHWAYS
RALEIGH, N.C.

STATE OF
NORTH CAROLINA
DEPT. OF TRANSPORTATION
DIVISION OF HIGHWAYS
RALEIGH, N.C.

ENGLISH DETAIL DRAWING FOR
CONCRETE MEDIAN DROP INLET TYPE 'A'
EXTRA DEPTH OVER 12' TO 25'
12" THRU 72" PIPE

SHEET 2 OF 2
840D17

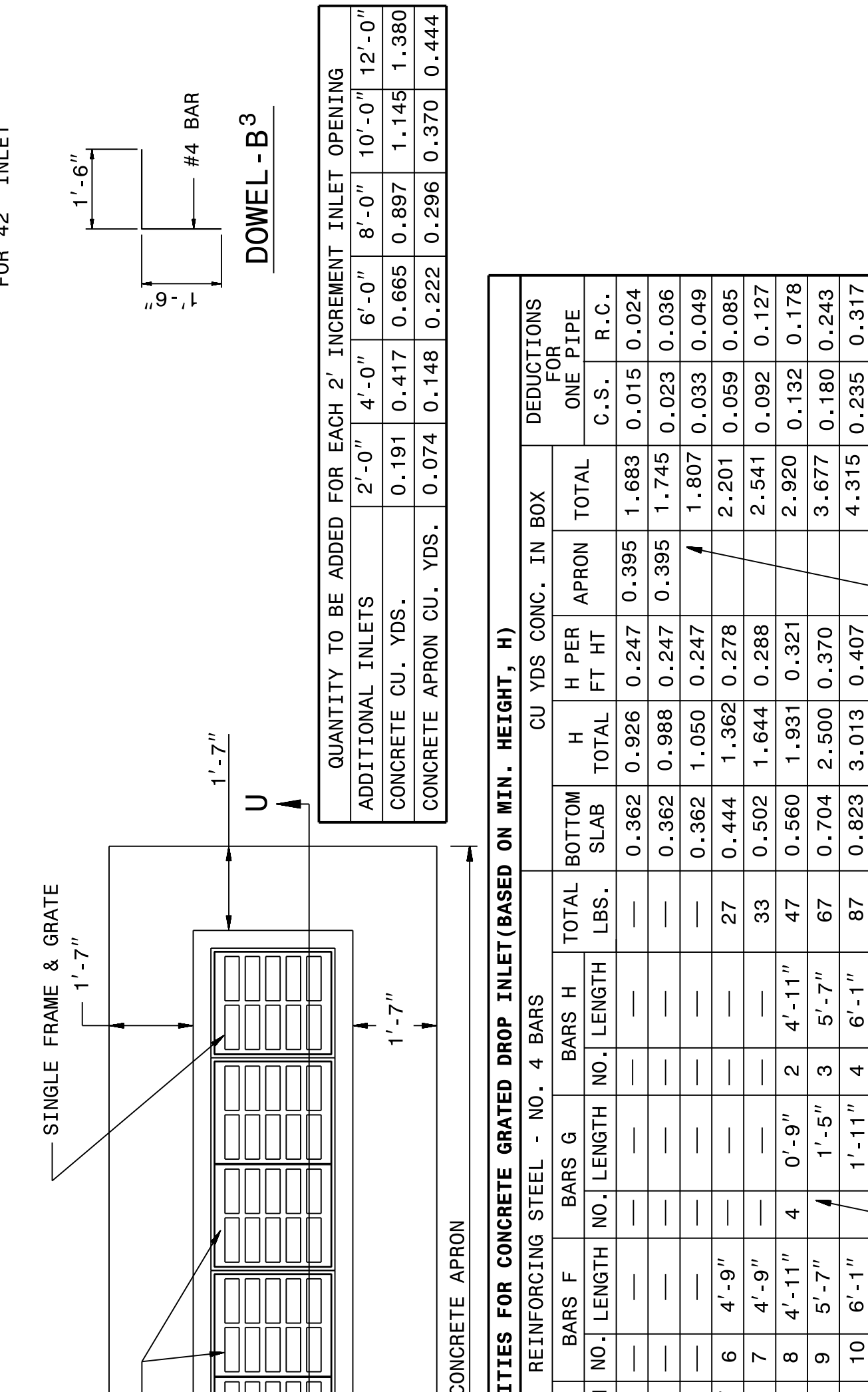
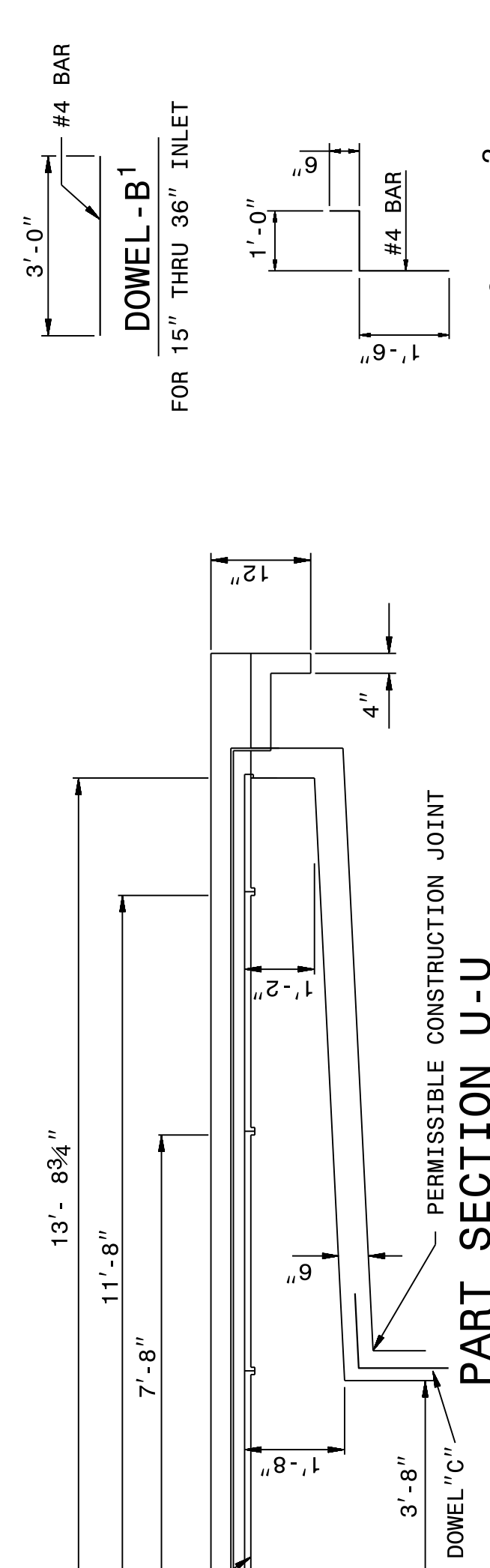
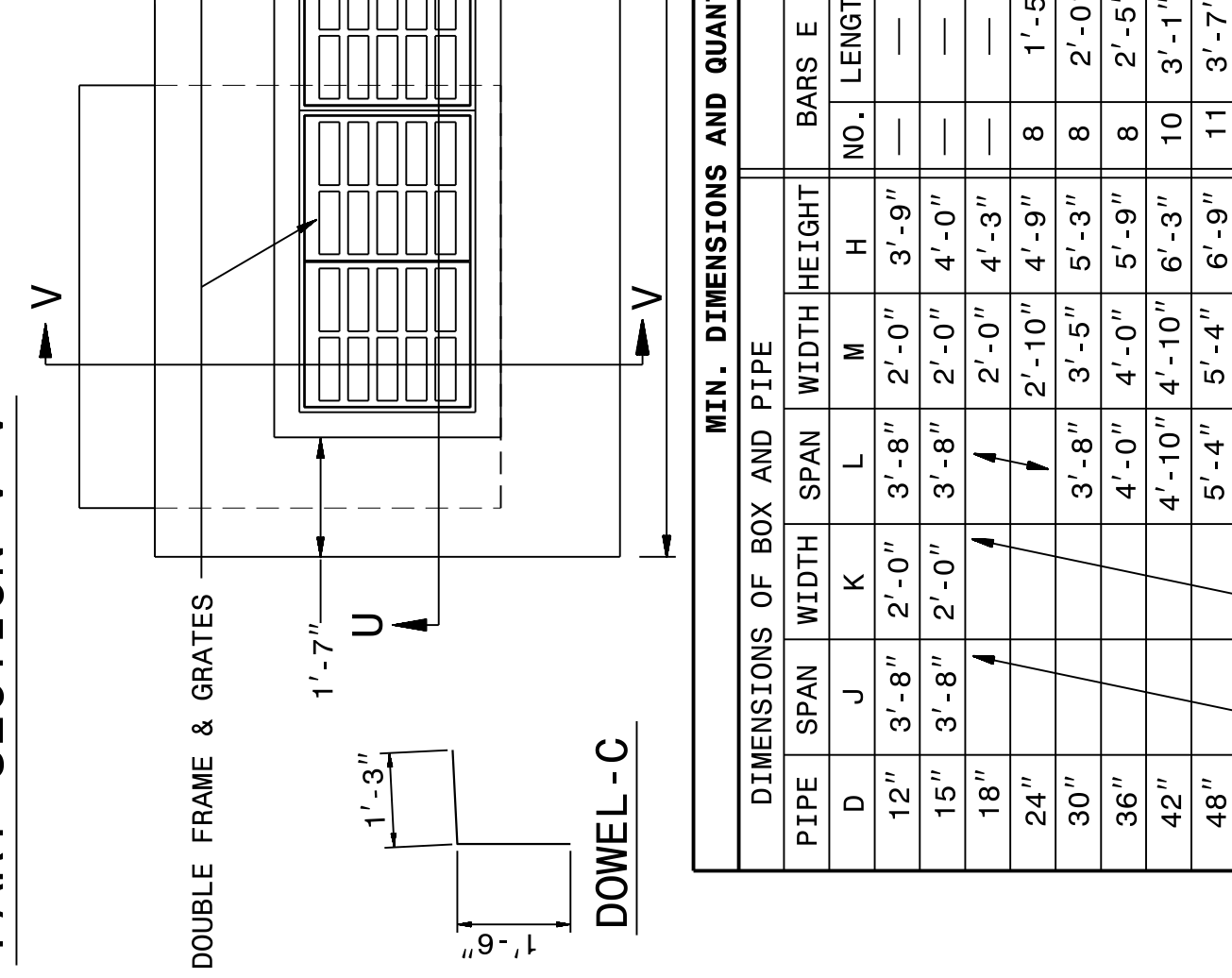
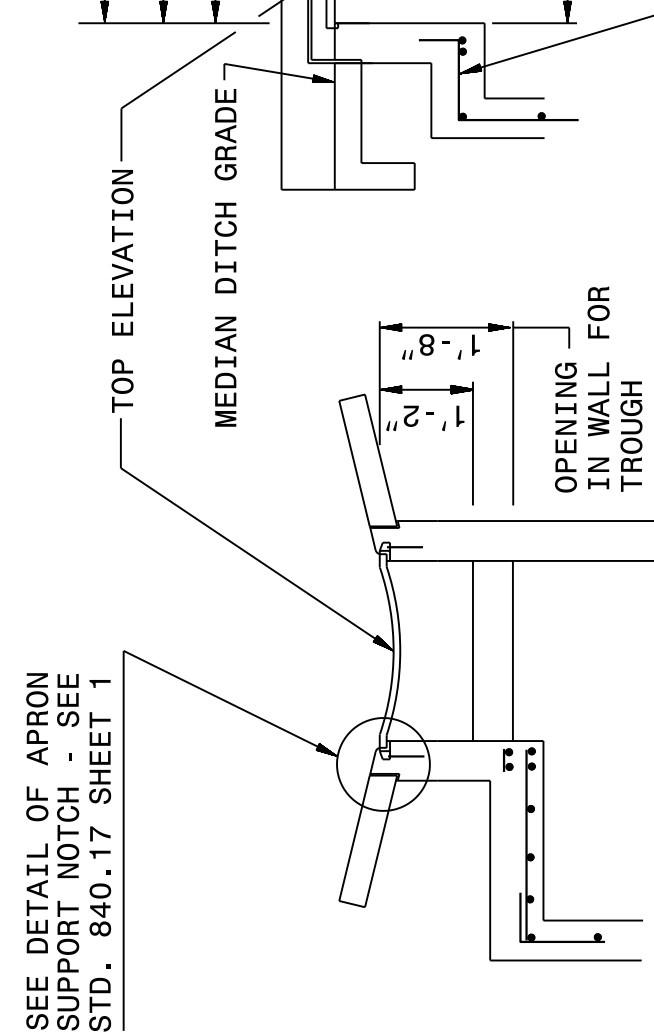

DIMENSIONS OF BOX AND PIPE	REINFORCING STEEL - NO. 4 BARS				CU YDS CONC. IN BOX		DEDUCTIONS FOR ONE PIPE				
	PIPE SPAN	WIDTH	SPAN	WIDTH	H	H PER	TOTAL	C.S.	R.C.		
12"	3'-8"	2'-0"	3'-8"	2'-0"	0.362	0.926	0.247	0.395	1.683	0.015	0.024
15"	3'-8"	2'-0"	3'-8"	2'-0"	0.362	0.988	0.247	0.395	1.745	0.023	0.036
18"	3'-8"	2'-0"	3'-8"	2'-0"	0.362	1.050	0.247	0.395	1.807	0.033	0.049
24"	3'-8"	2'-0"	3'-8"	2'-0"	0.444	1.362	0.278	0.428	2.201	0.059	0.085
30"	3'-8"	2'-0"	3'-8"	2'-0"	0.502	1.644	0.288	0.428	2.541	0.092	0.127
36"	4'-0"	4'-0"	4'-0"	4'-0"	0.560	1.931	0.321	0.428	2.920	0.132	0.178
42"	4'-10"	4'-10"	4'-10"	4'-10"	0.704	2.500	0.370	0.428	3.677	0.180	0.243
48"	5'-4"	5'-4"	5'-4"	5'-4"	0.823	3.013	0.407	0.428	4.315	0.235	0.317
54"	6'-0"	6'-0"	6'-0"	6'-0"	0.951	3.589	0.444	0.428	5.072	0.297	0.401
60"	6'-6"	6'-6"	6'-6"	6'-6"	1.311	4.539	0.494	0.428	6.170	0.367	0.495
66"	7'-2"	7'-2"	7'-2"	7'-2"	1.136	5.061	0.537	0.428	6.901	0.444	0.599
72"	3'-8"	2'-0"	7'-8"	8'-9"	1.500	5.860	0.560	0.395	7.868	0.528	0.713

QUANTITY TO BE ADDED FOR EACH 2' INCREMENT INLET OPENING

ADDITIONAL INLETS	2'-0"	4'-0"	6'-0"	8'-0"	10'-0"	12'-0"
CONCRETE CU. YDS.	0.191	0.417	0.665	0.897	1.145	1.380
CONCRETE APRON CU. YDS.	0.074	0.148	0.222	0.296	0.370	0.444

CONTRACT STANDARDS AND DEVELOPMENT UNIT
Office 919-707-6950 FAX 919-250-4119

SEE PLATE FOR TITLE

ORIGINAL BY: 2002 STD.840.1 DATE: _____
MODIFIED BY: K.A. KEMPF DATE: 07-06-09
CHECKED BY: _____ DATE: _____
FILE SPEC.: /stand/840d17 Extra Depth 2GI.dgn

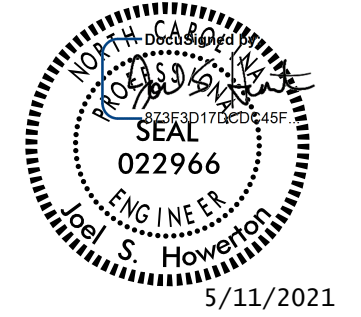

5/11/2021

DOCUMENT NOT CONSIDERED FINAL UNLESS ALL SIGNATURES COMPLETED

8/17/99

VARIABLE WIDTH BASE DITCH -HGR- 52 + 75 LT

(NOT TO SCALE)

PROJECT REFERENCE NO. 15614.1075010	SHEET NO. 2D-13
RW SHEET NO.	
HYDRAULICS ENGINEER	
DOCUMENT NOT CONSIDERED FINAL UNLESS ALL SIGNATURES COMPLETED	
TGS ENGINEERS 804-C N. LAFAYETTE ST SHELBY, NC 28150 PH (704) 476-0003 CORP. LICENSE NO.: C-0275	

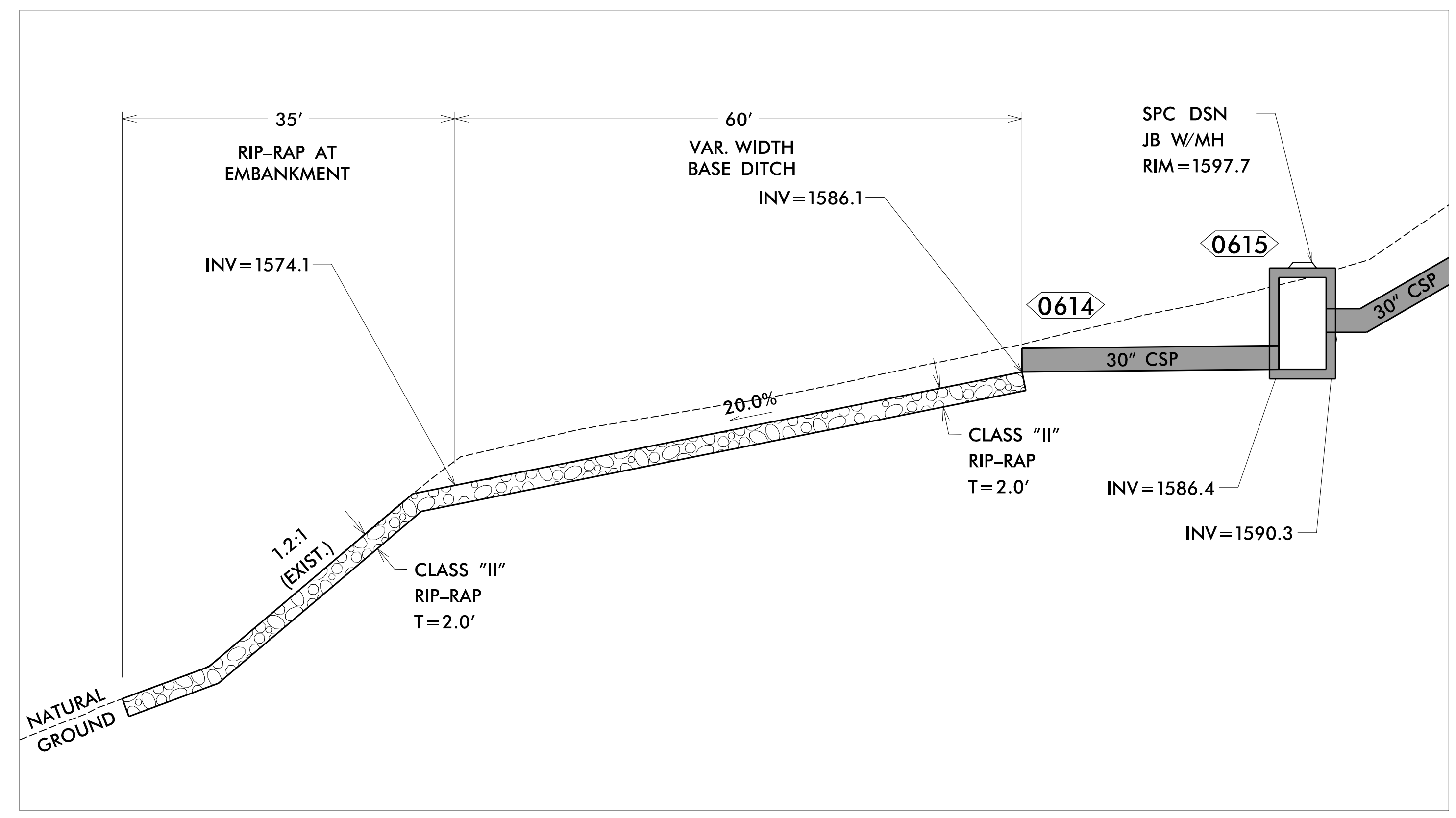

PROFILE VIEW

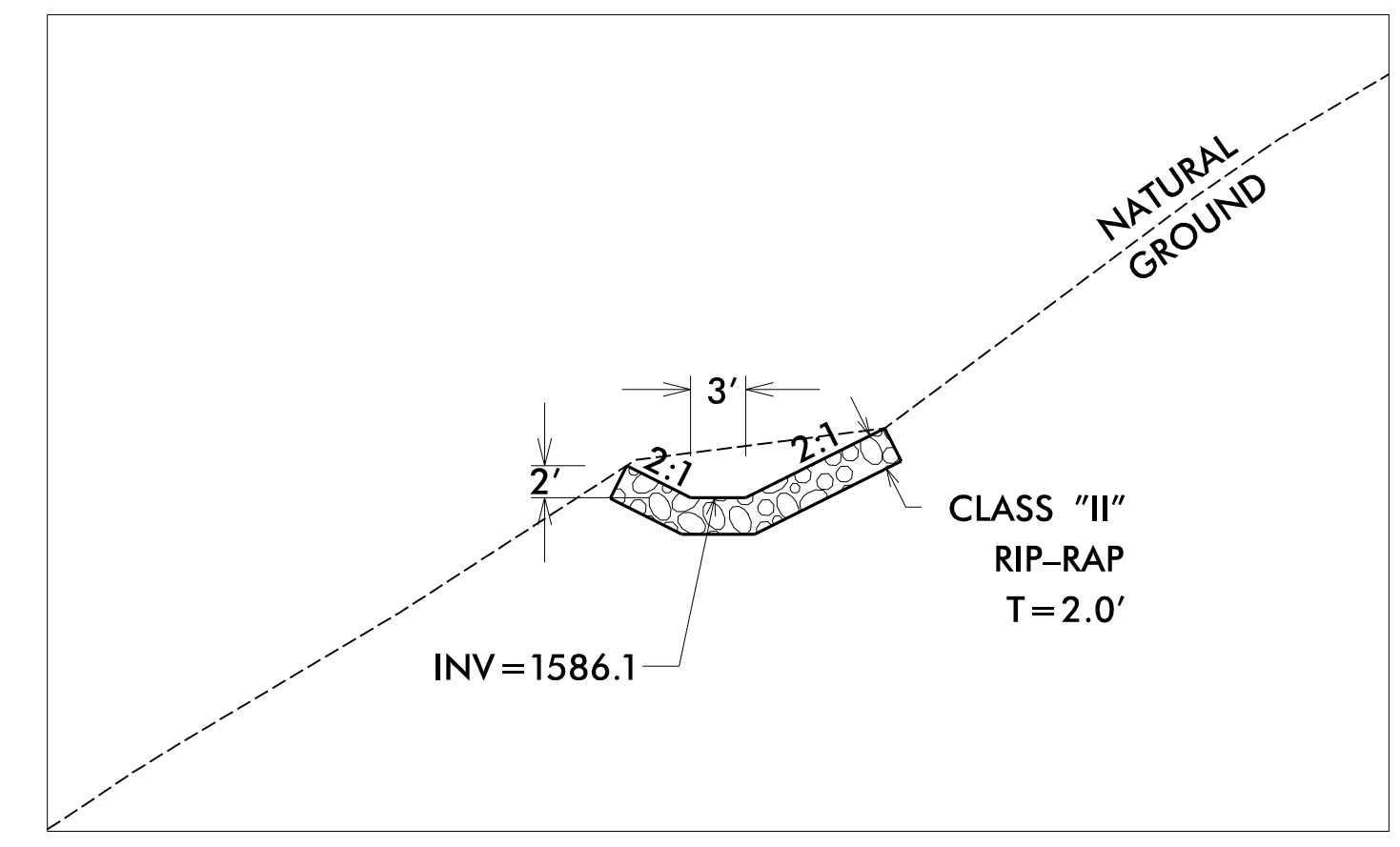

SECTION A-A

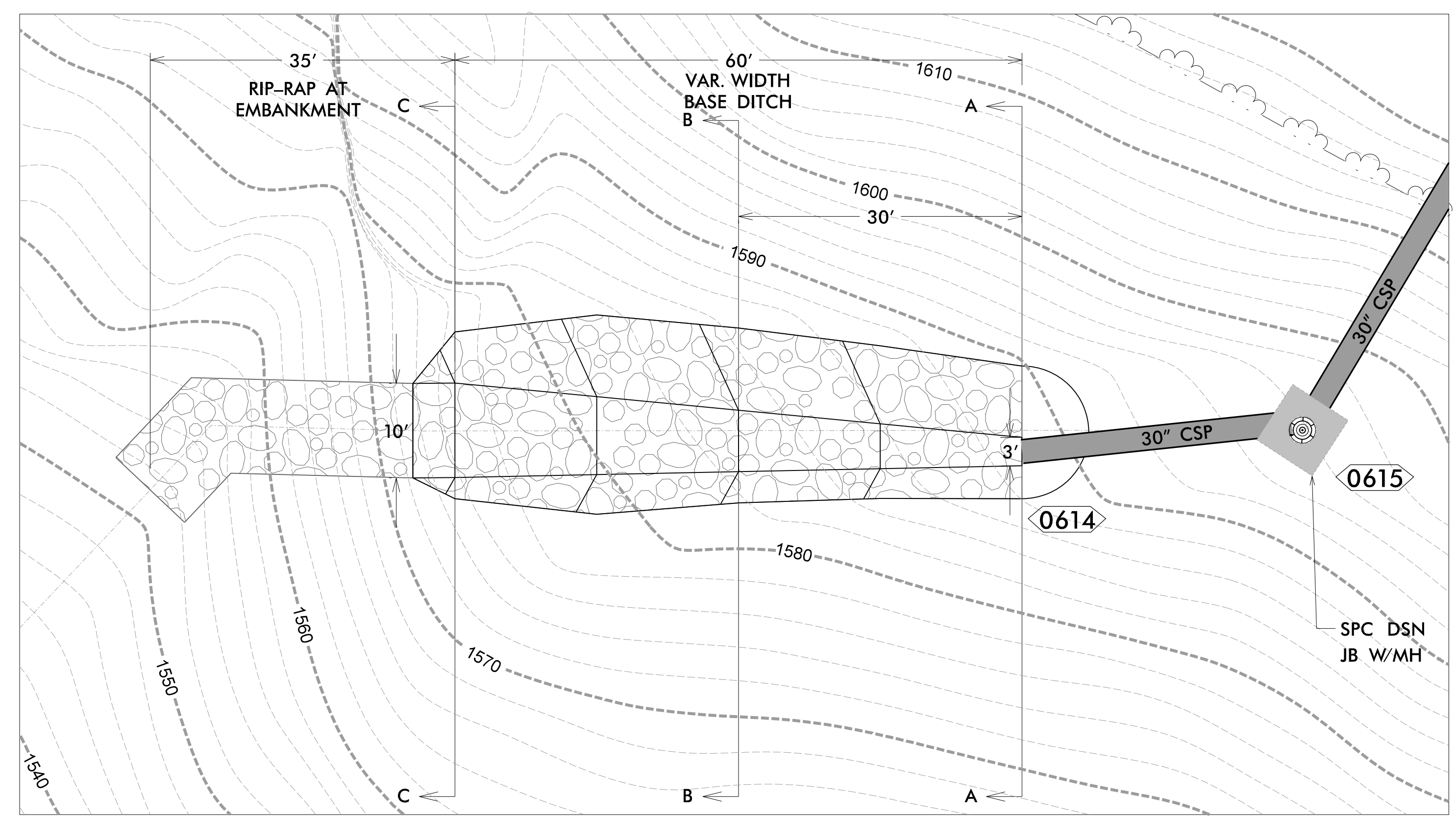

PLAN VIEW

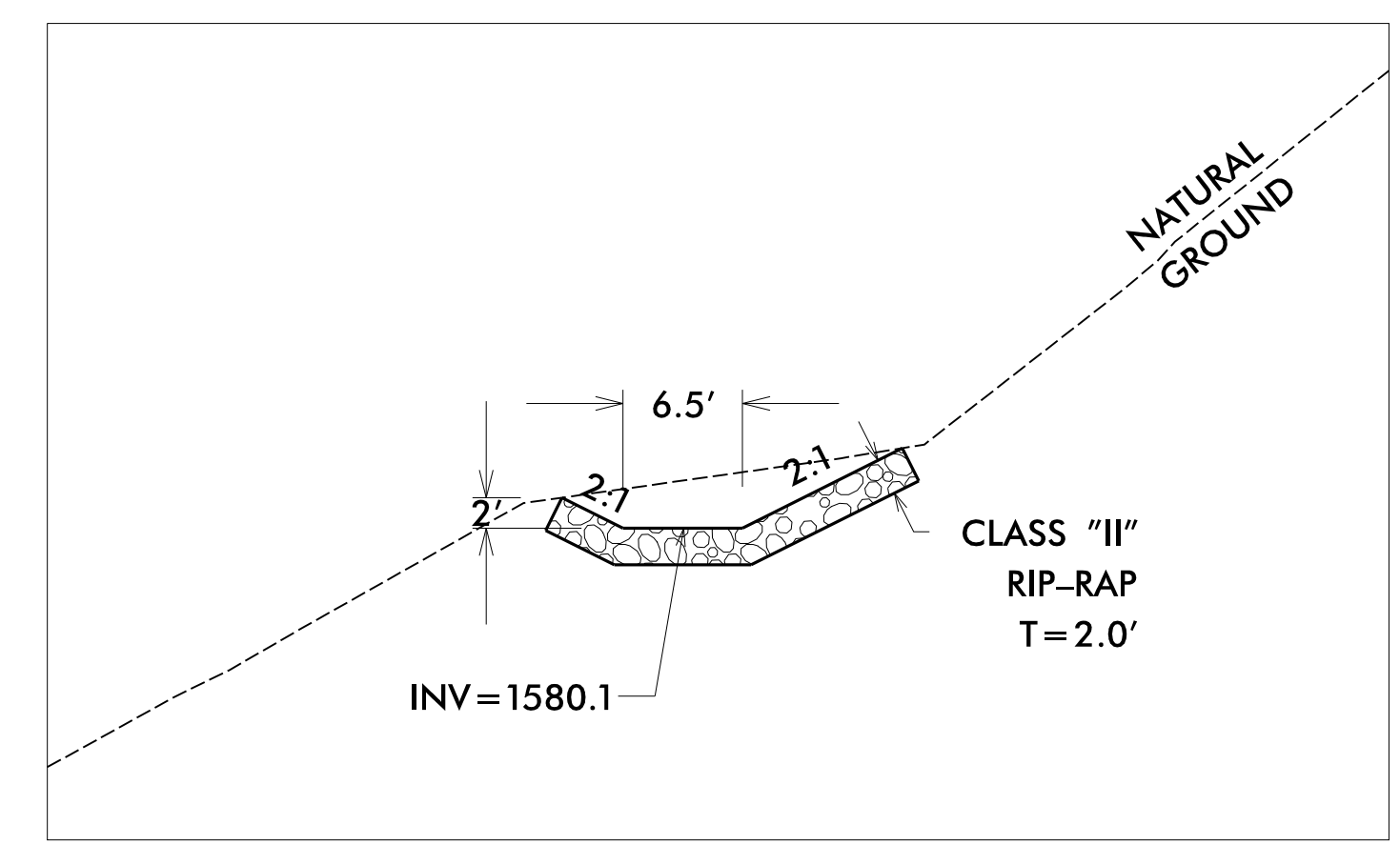

SECTION B-B

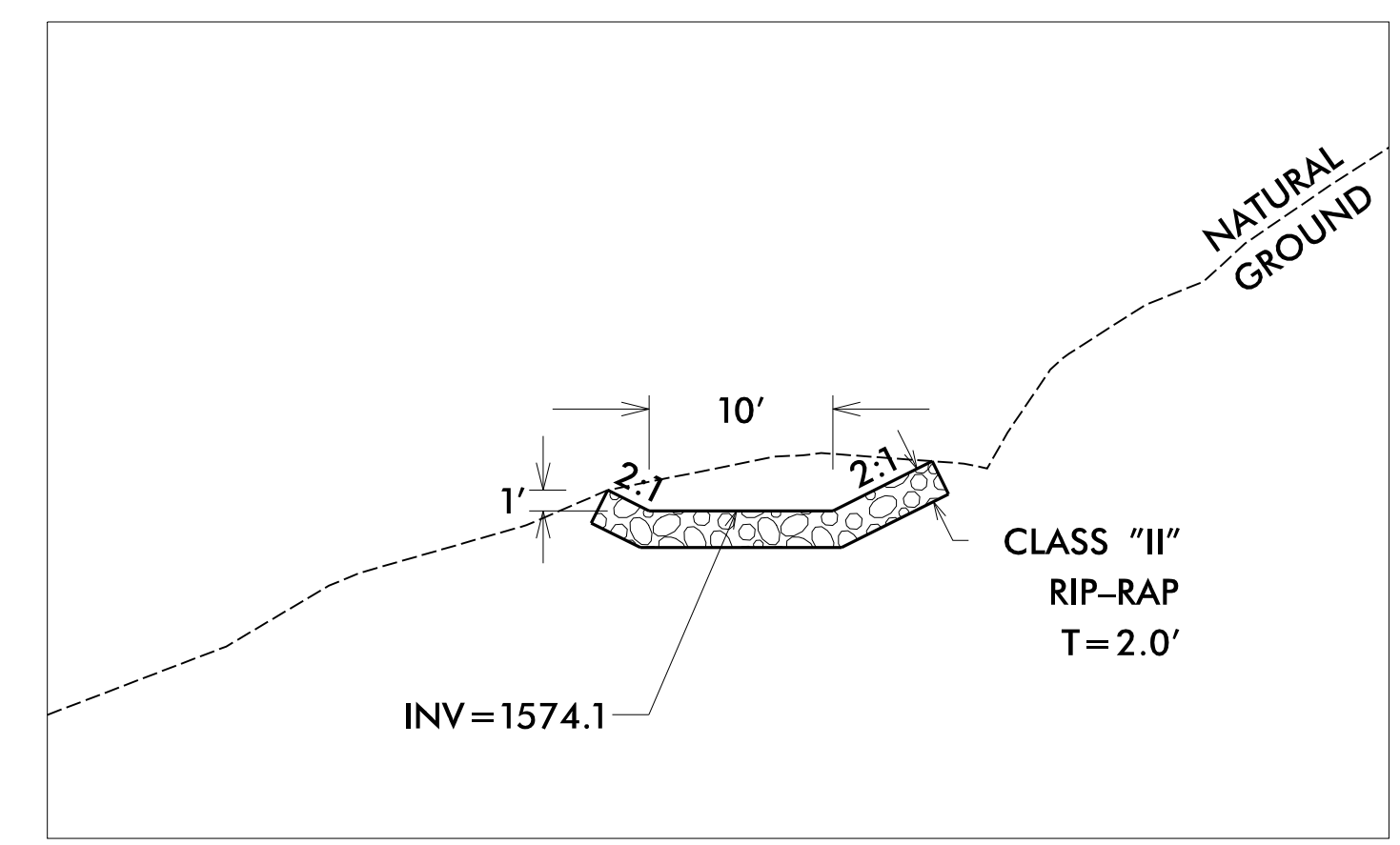

SECTION C-C

REVISIONS

4/6/2021 X:\NC\0611-26 Howard Gap Rd Rehab\Drainage\26 Howard Gap_Hydr_Base_Ditch_PSH.dgn User:benegar

8/17/99
4/6/2021
X:\NG0001\1-26 Howard Gap Rd Rehab\Drainage\1-26 Howard Gap_Hyd_Basin_1.PSH.dgn
User:benegar

ENERGY DISSIPATOR BASIN #1 -HGR- 37+50 LT

SHEET 1 OF 3
(NOT TO SCALE)

PROJECT REFERENCE NO. 15614.1075010	SHEET NO. 20-14
RW SHEET NO.	
HYDRAULICS ENGINEER	
DOCUMENT NOT CONSIDERED FINAL UNLESS ALL SIGNATURES COMPLETED	
TGS ENGINEERS 804-C N. LAFAYETTE ST SHELBY, NC 28150 PH (704) 476-0003 CORP. LICENSE NO.: C-0275	

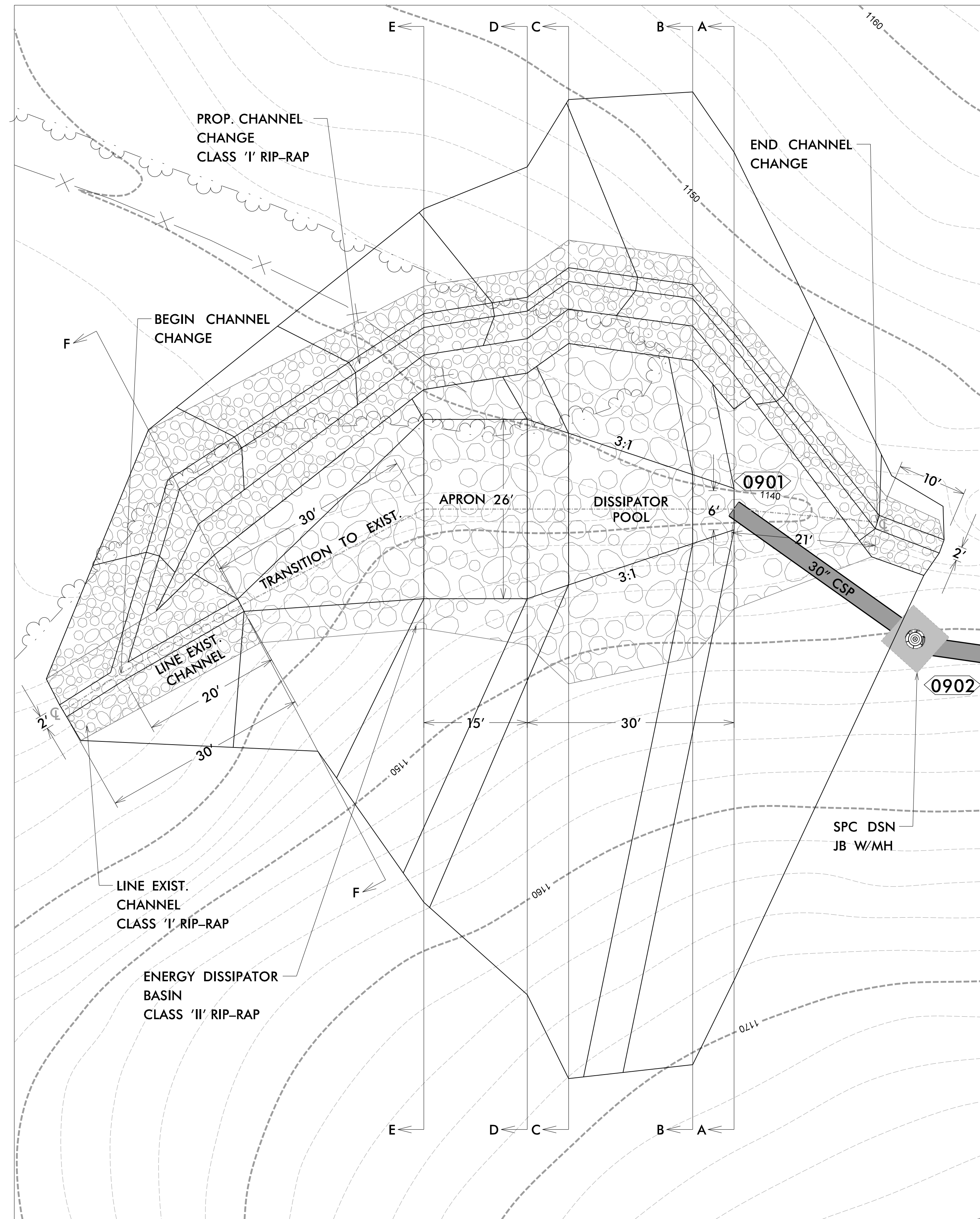

PLAN VIEW

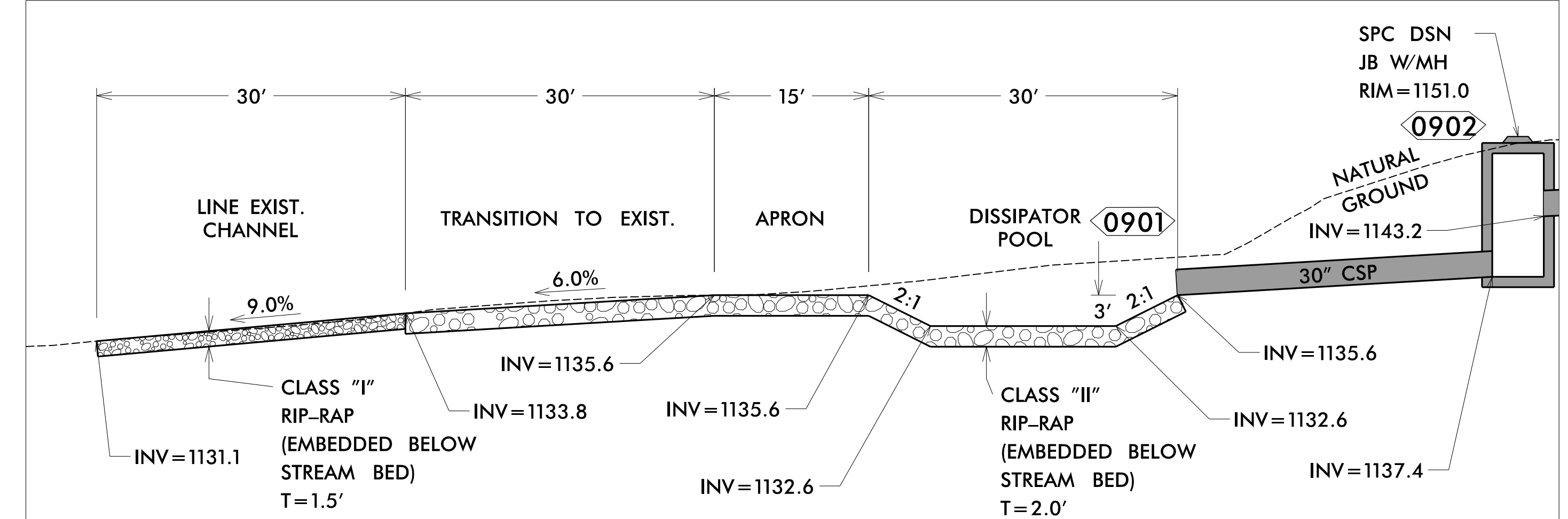

PROFILE VIEW

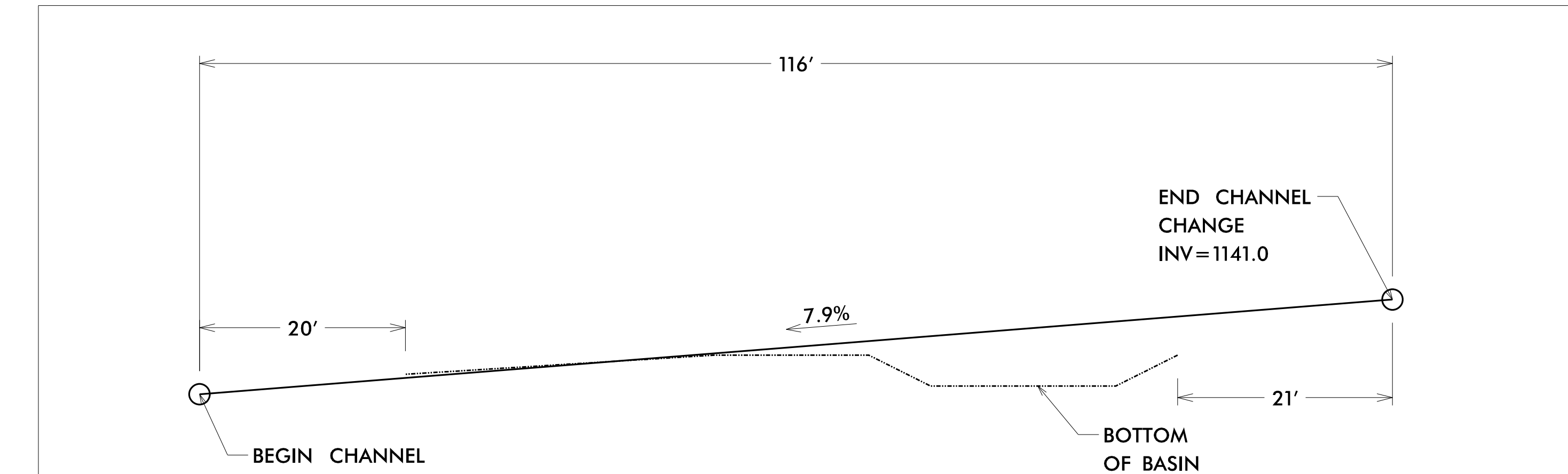

NOTES:

1. A 2' BASE CHANNEL WILL BE FORMED AROUND THE BASIN AND LINED WITH CLASS 'I' RIP-RAP (EMBEDDED BELOW THE PROPOSED STREAM BED).
2. DISTANCES SHOWN ABOVE ARE MEASURED ALONG THE CENTERLINE OF THE BASIN.

PROPOSED CHANNEL CHANGE PROFILE

8/17/99

ENERGY DISSIPATOR BASIN #1 -HGR- 37+50 LT

SHEET 2 OF 3
(NOT TO SCALE)

PROJECT REFERENCE NO. 15614.1075010	SHEET NO. 20-15
RW SHEET NO.	
HYDRAULICS ENGINEER	
DOCUMENT NOT CONSIDERED FINAL UNLESS ALL SIGNATURES COMPLETED	
	TGS ENGINEERS 804-C N. LAFAYETTE ST SHELBY, NC 28150 PH (704) 476-0003 CORP. LICENSE NO.: C-0275

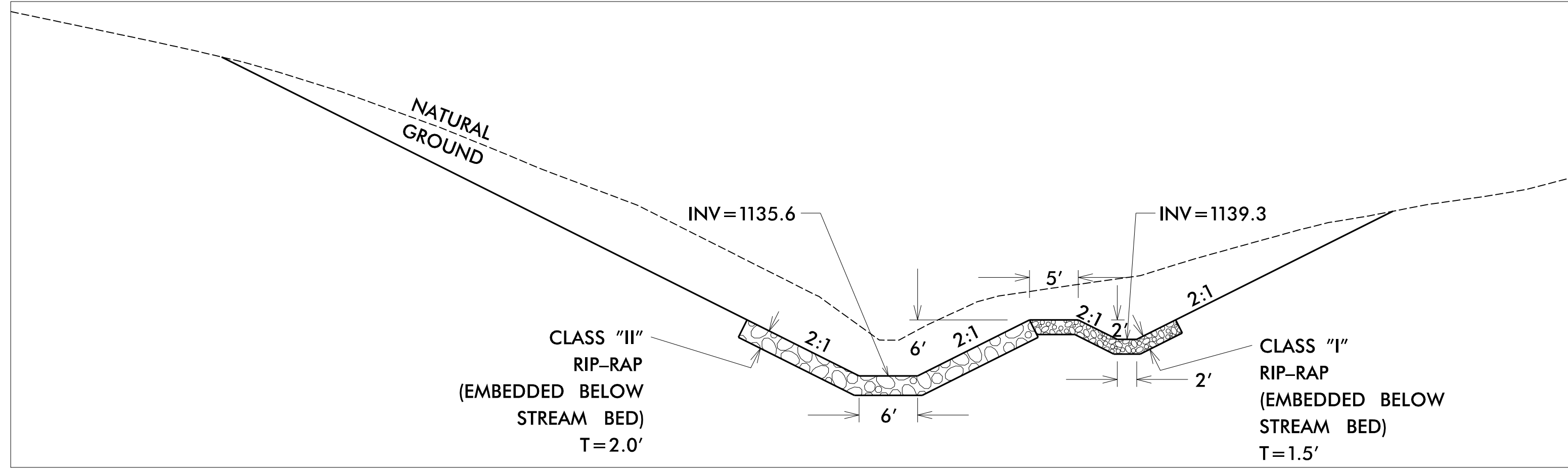

SECTION A-A

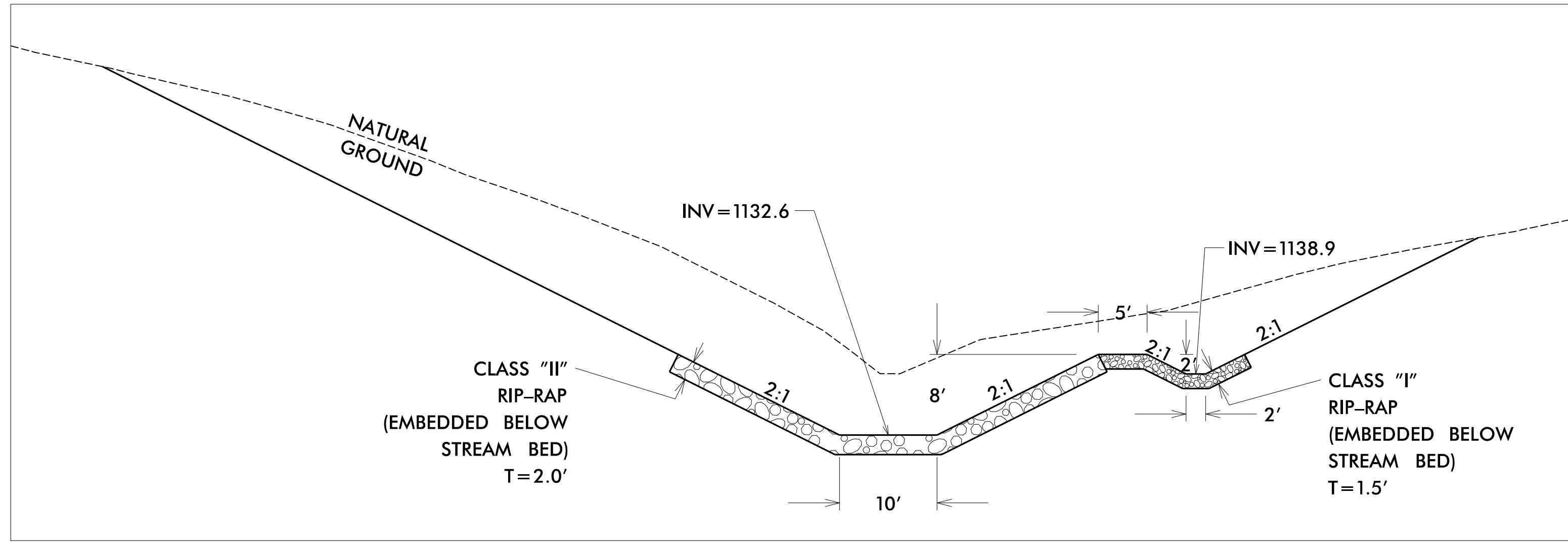

SECTION B-B

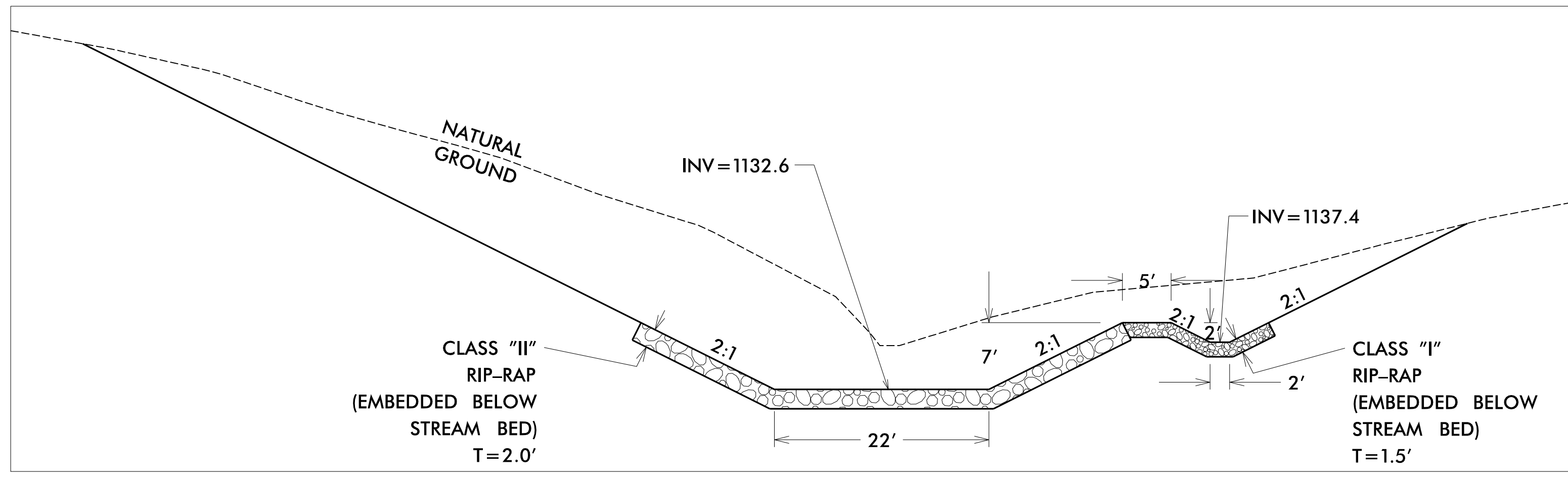

SECTION C-C

4/6/2021
X:\N6006\1-26 Howard Gap Rd Rehab\Drainage\1-26 Howards Gap_Hydr_Basin_1.PSH.dgn
User:bjhenegar

8/17/99

ENERGY DISSIPATOR BASIN #1 -HGR- 37+50 LT

SHEET 3 OF 3 (NOT TO SCALE)

PROJECT REFERENCE NO. 15614.1075010	SHEET NO. 2D-16
RW SHEET NO.	
HYDRAULICS ENGINEER	
DOCUMENT NOT CONSIDERED FINAL UNLESS ALL SIGNATURES COMPLETED	
	TGS ENGINEERS 804-C N. LAFAYETTE ST SHELBY, NC 28150 PH (704) 476-0003 CORP. LICENSE NO.: C-0275

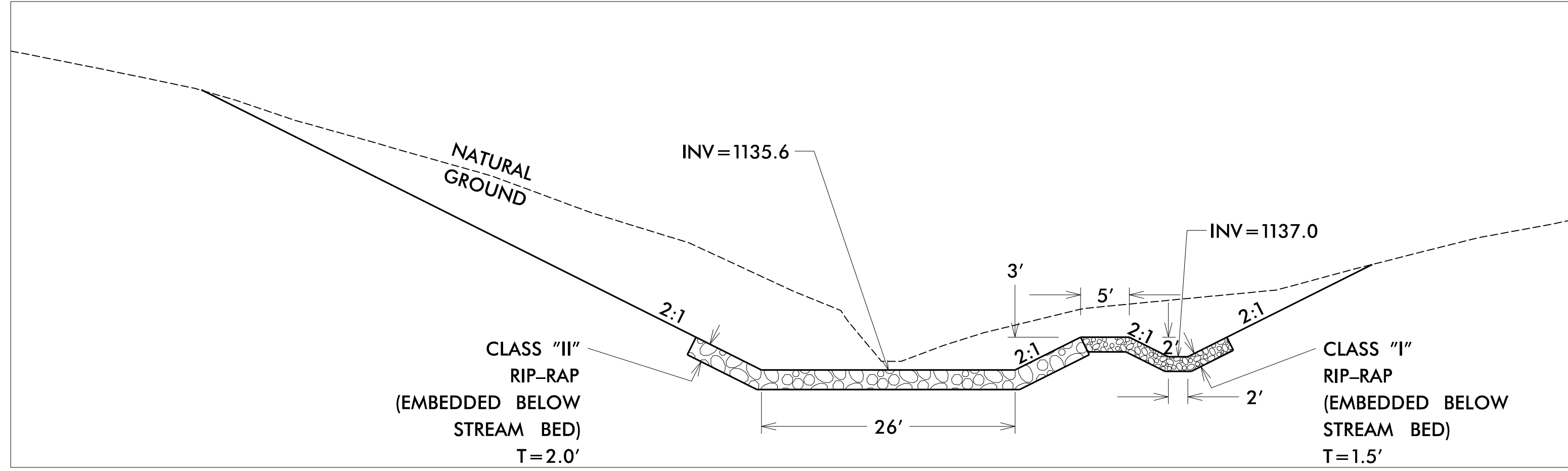

SECTION D-D

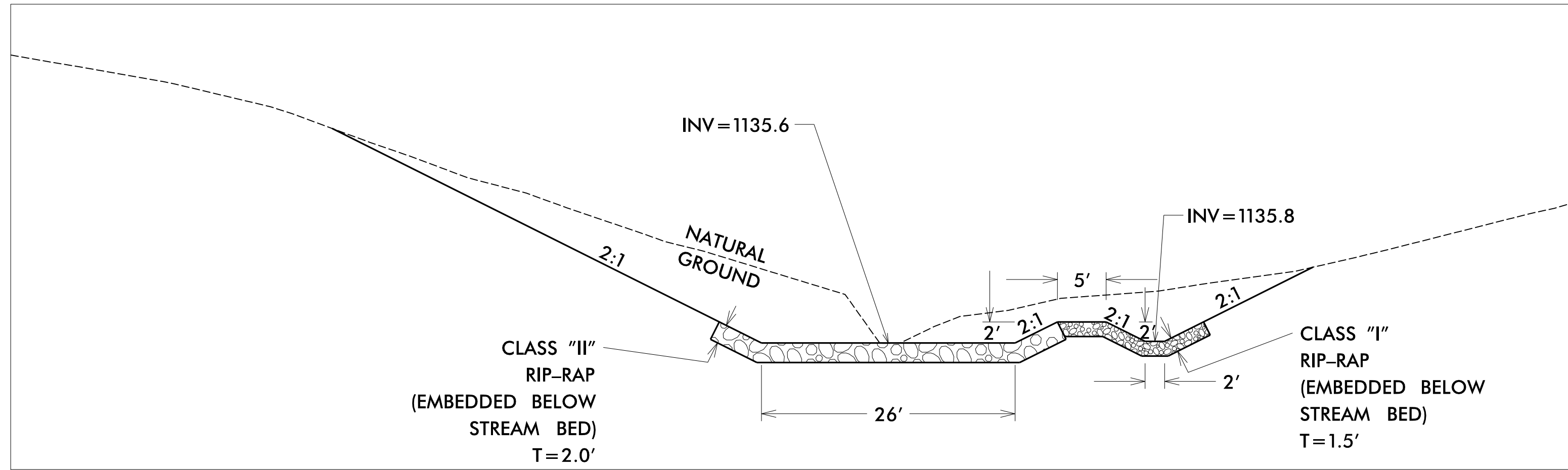

SECTION E-E

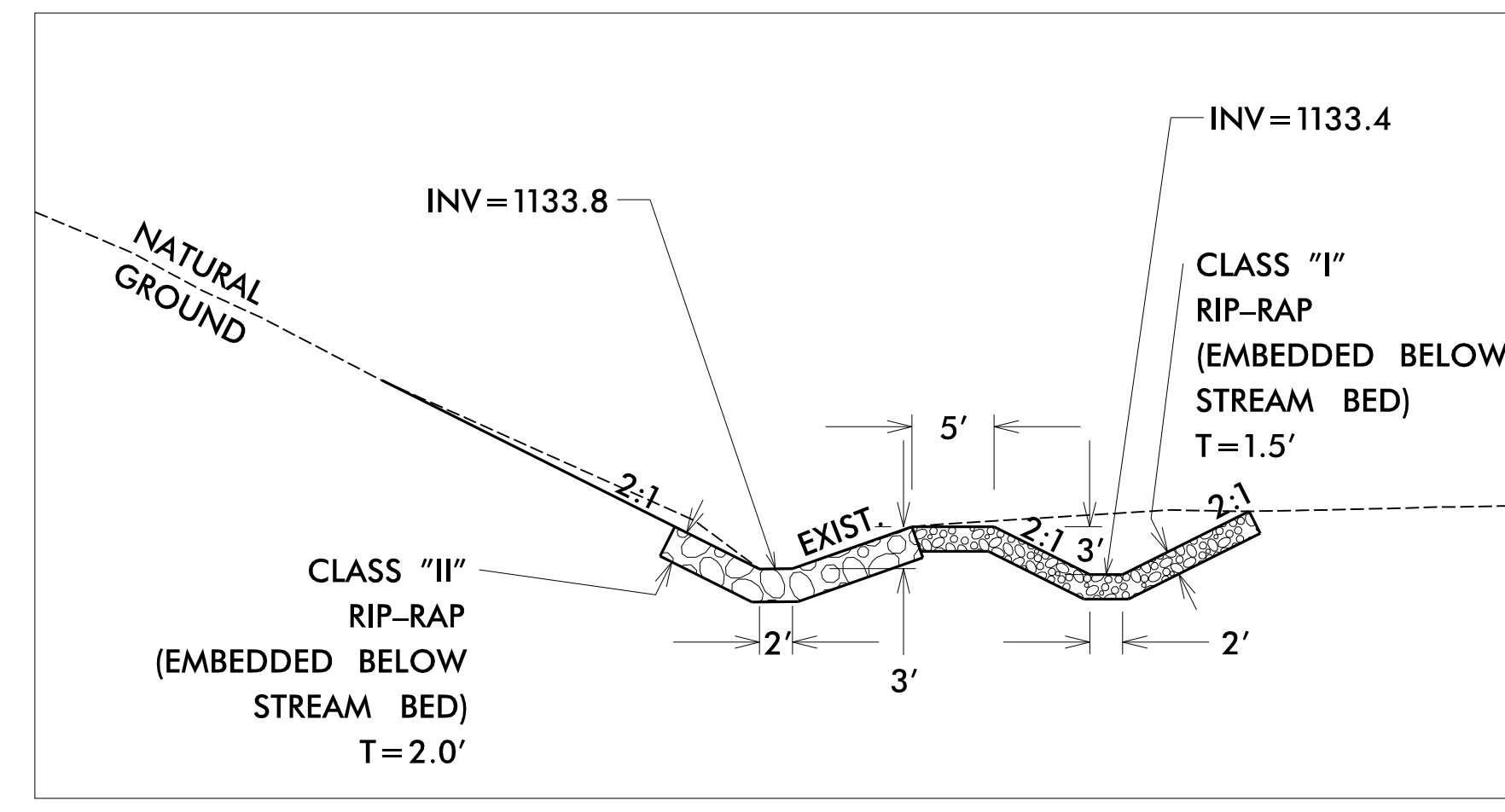

SECTION F-F

4/7/2021 4:56:00 PM I-26 Howard Gap Rd Rehab Drainage I-26 Howard Gap_Hydr_Basin_1.PSH.dgn User:benegar

FOREBAY #1 -126- 453+30 RT

SHEET 1 OF 2
(NOT TO SCALE)

PROJECT REFERENCE NO. 15614.1075010	SHEET NO. 2D-17
RW SHEET NO.	
HYDRAULICS ENGINEER	
DOCUMENT NOT CONSIDERED FINAL UNLESS ALL SIGNATURES COMPLETED	
TGS ENGINEERS 804-C N. LAFAYETTE ST SHELBY, NC 28150 PH (704) 476-0003 CORP. LICENSE NO.: C-0275	

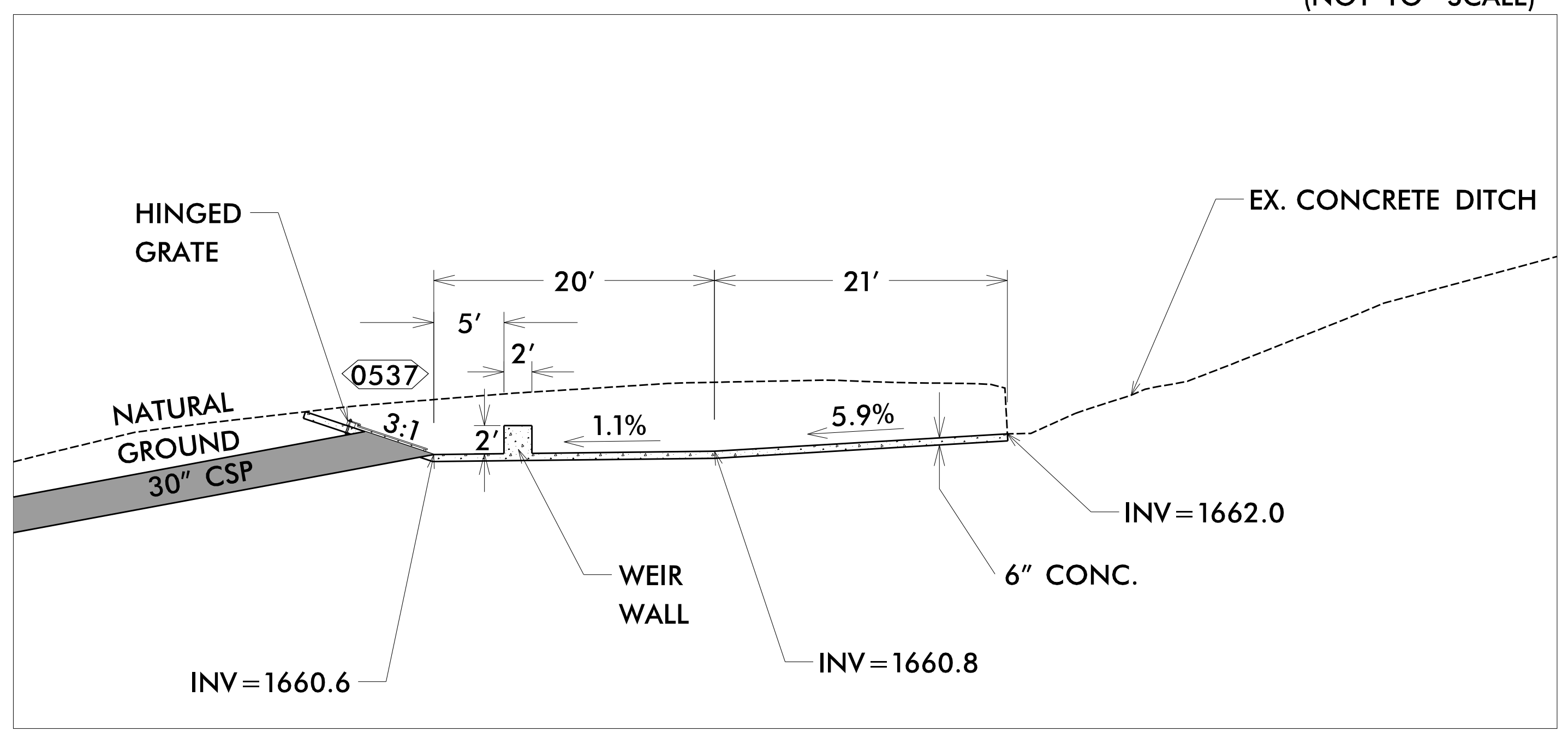

PROFILE VIEW

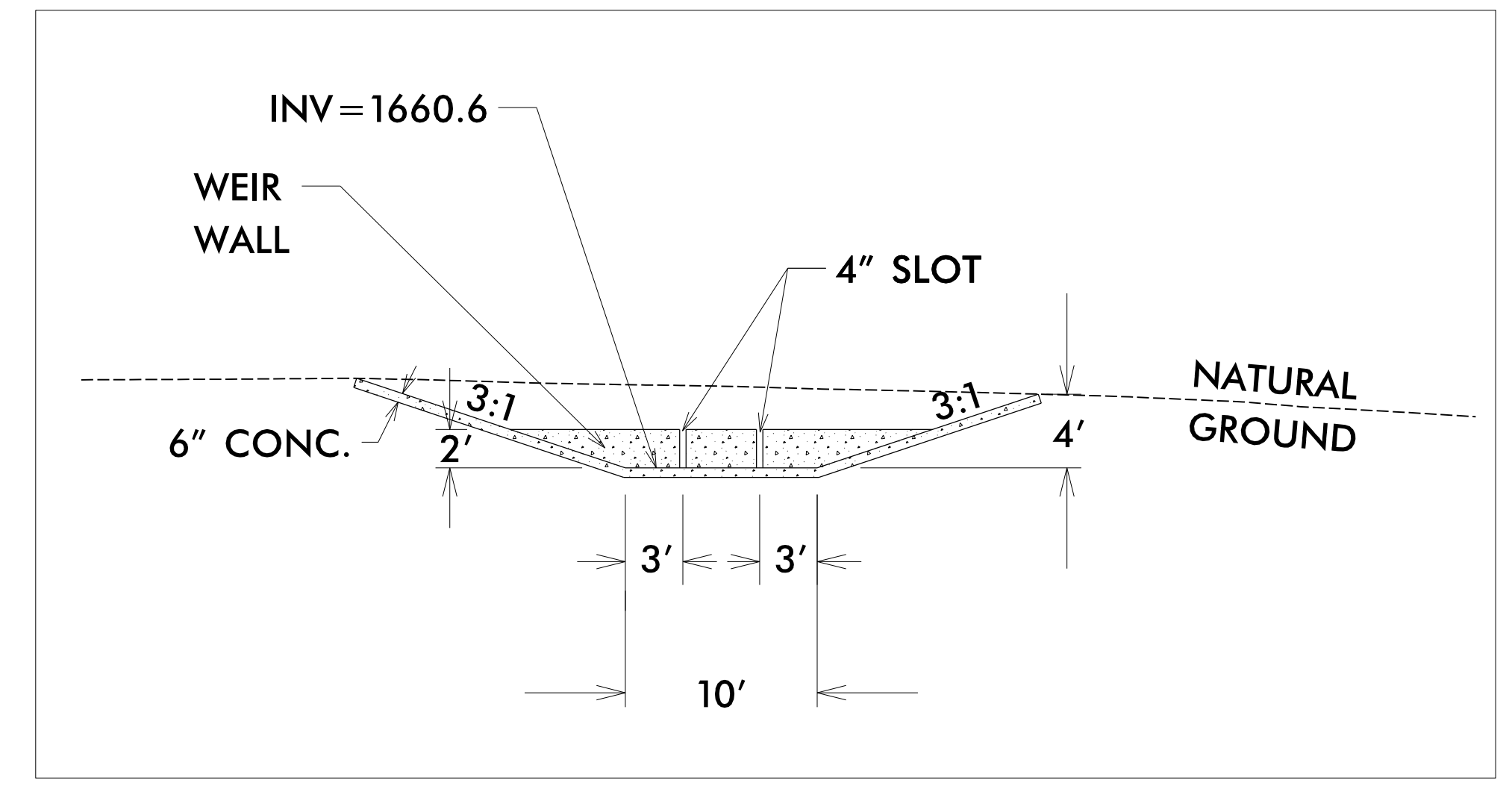

SECTION A-A

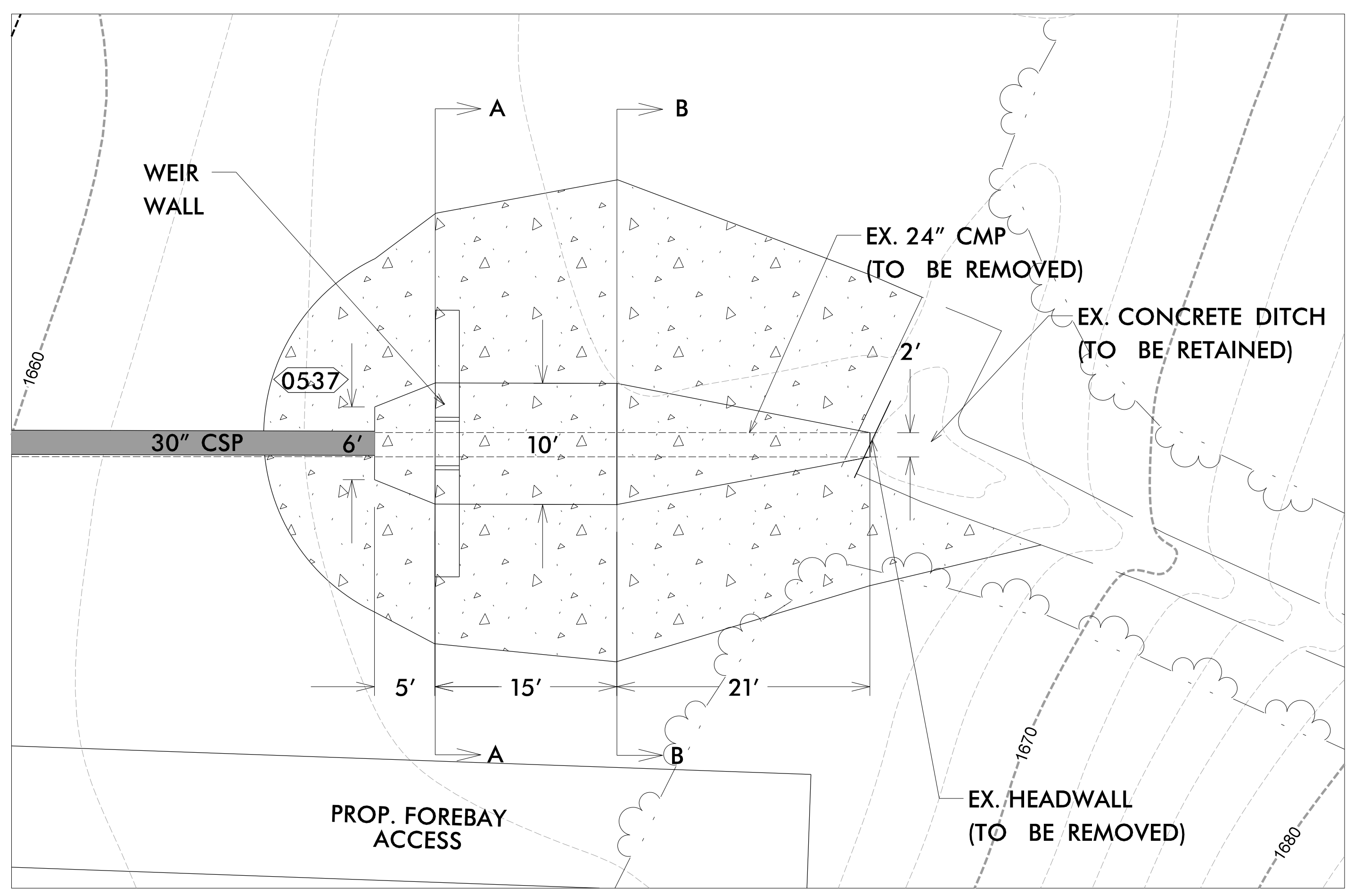

PLAN VIEW

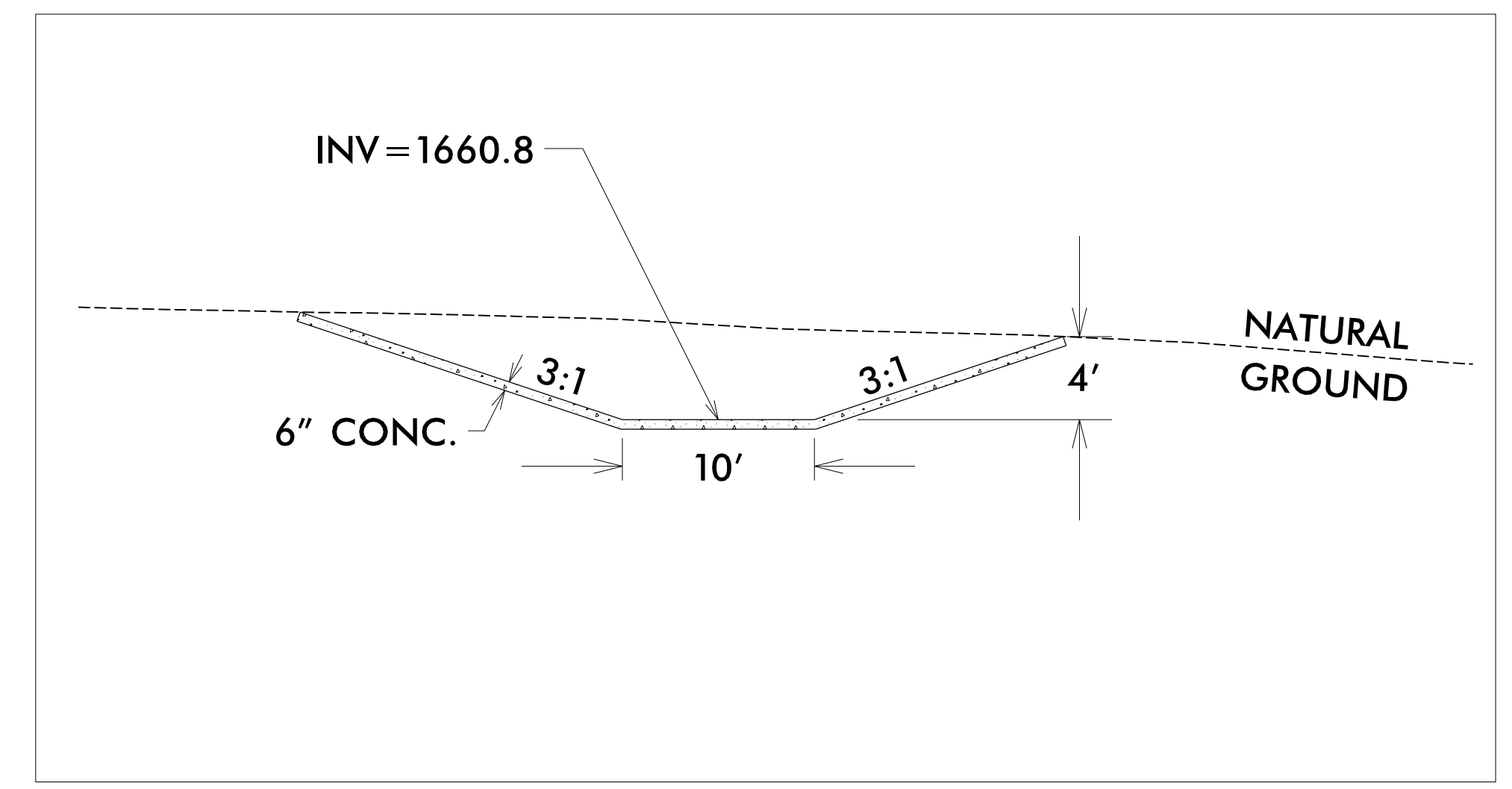

SECTION B-B

8/17/99

FOREBAY #1 -126- 453+30 RT

SHEET 2 OF 2
(NOT TO SCALE)

Hinged Grate

30" Pipe 3:1 Slope

PROJECT REFERENCE NO. 15614.1075010	SHEET NO. 20-18
R/W SHEET NO.	
HYDRAULICS ENGINEER	
DOCUMENT NOT CONSIDERED FINAL UNLESS ALL SIGNATURES COMPLETED	
	TGS ENGINEERS 804-C N. LAFAYETTE ST SHELBY, NC 28150 PH: (704) 476-0003 CORP. LICENSE NO.: C-0275

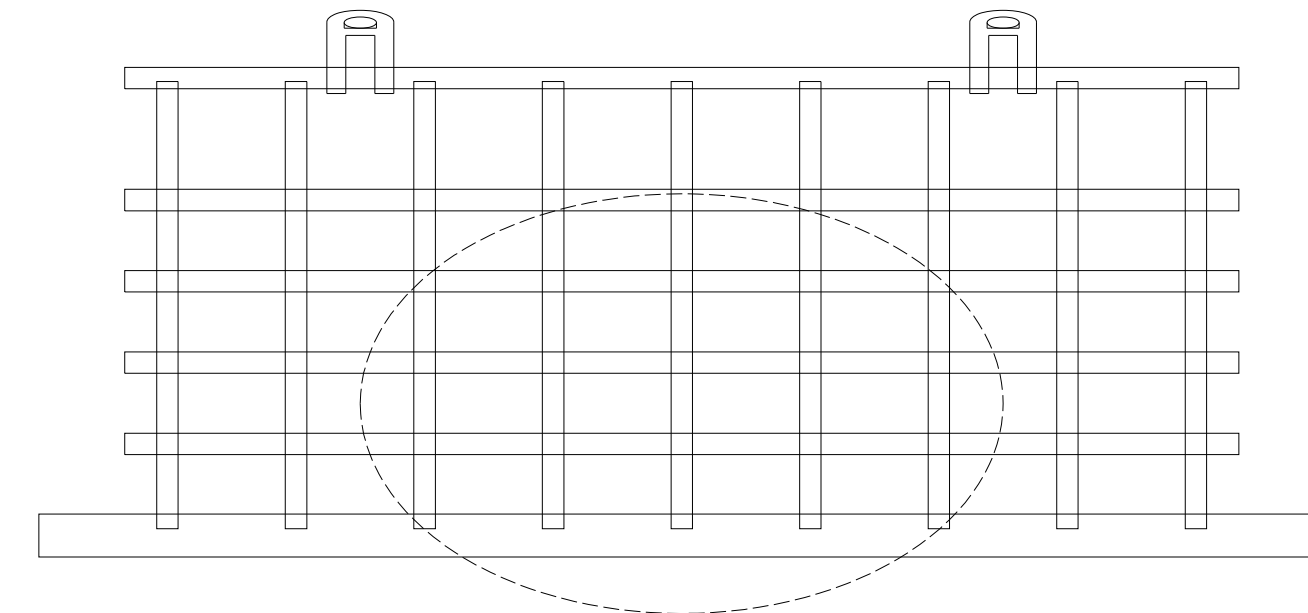
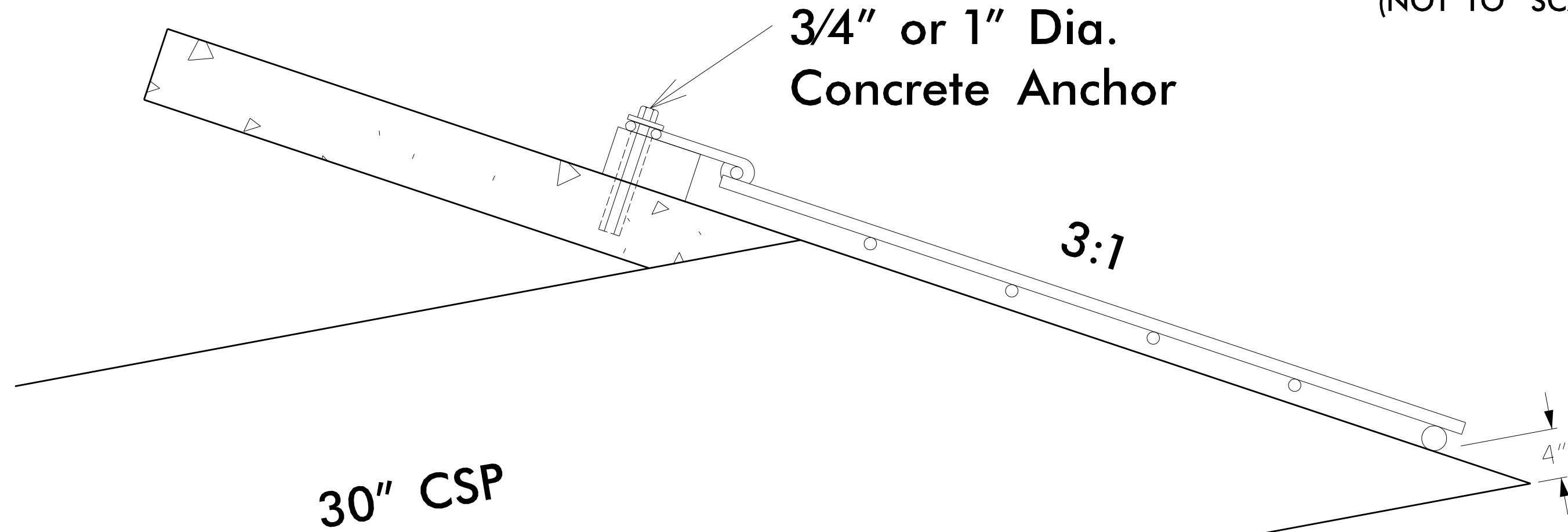

HINGED GRATE NOTES:

- ALL JOINTS, EXCEPT AS NOTED, SHALL BE FULLY WELDED AROUND JOINT WITH A MINIMUM OF A 1/4" BEAD.
- GRATE SHALL BE REBAR AND GALVANIZED IN ACCORDANCE WITH ASTM A-153.
- SPACER SHALL CONFORM TO AASHTO M270 GRADE 36. AFTER FABRICATION, HOT-DIP GALVANIZE SPACER IN ACCORDANCE WITH AASHTO M111.
- USE CONCRETE ANCHORS CONSISTING OF A STUD BOLT WITH NUT AND WASHER. USE STUDS THREADED ON ONE END AND HAVING AN EXPANDED WEDGE ASSEMBLY POSITIONED AROUND A TAPERED AREA AT THE OTHER END. USE ANCHORS WHICH PROVIDE A MINIMUM SAFE HOLDING POWER OF 2875 LBS. FOR A 3/4" OR 1" DIAMETER BOLT. CALCULATE HOLDING POWER BASED ON 1/4 THE ACTUAL HOLDING POWER OF THE ANCHOR IN 3500 PSI CONCRETE AS DETERMINED BY AN APPROVED COMMERCIAL TESTING LABORATORY.
- USE ANCHORS GALVANIZED IN ACCORDANCE WITH ASTM A-153. SIZE HOLES FOR THE CONCRETE ANCHORS IN ACCORDANCE WITH THE ANCHOR MANUFACTURER'S RECOMMENDATIONS. DRILL HOLES WITH A CARBIDE OR DIAMOND TIPPED MASONRY BIT POWERED BY A ROTARY OR ROTARY IMPACT DRILL. NO OTHER IMPACT TOOLS WILL BE PERMITTED. DRILL HOLES VERTICALLY. FURNISH DOCUMENTATION OF HOLE SIZE RECOMMENDED FOR THE SPECIFIED ANCHOR TO THE ENGINEER BEFORE DRILLING HOLES. THOROUGHLY CLEAN HOLES FOR ANCHORS OF ALL CONCRETE CHIPS, DUST, GREASE, OIL, ETC. BEFORE ANCHORS ARE INSTALLED. REPAIR ALL DAMAGE CAUSED BY THIS WORK TO THE SATISFACTION OF THE ENGINEER.
- FOR HINGED GRATE, SEE SPECIAL PROVISIONS.

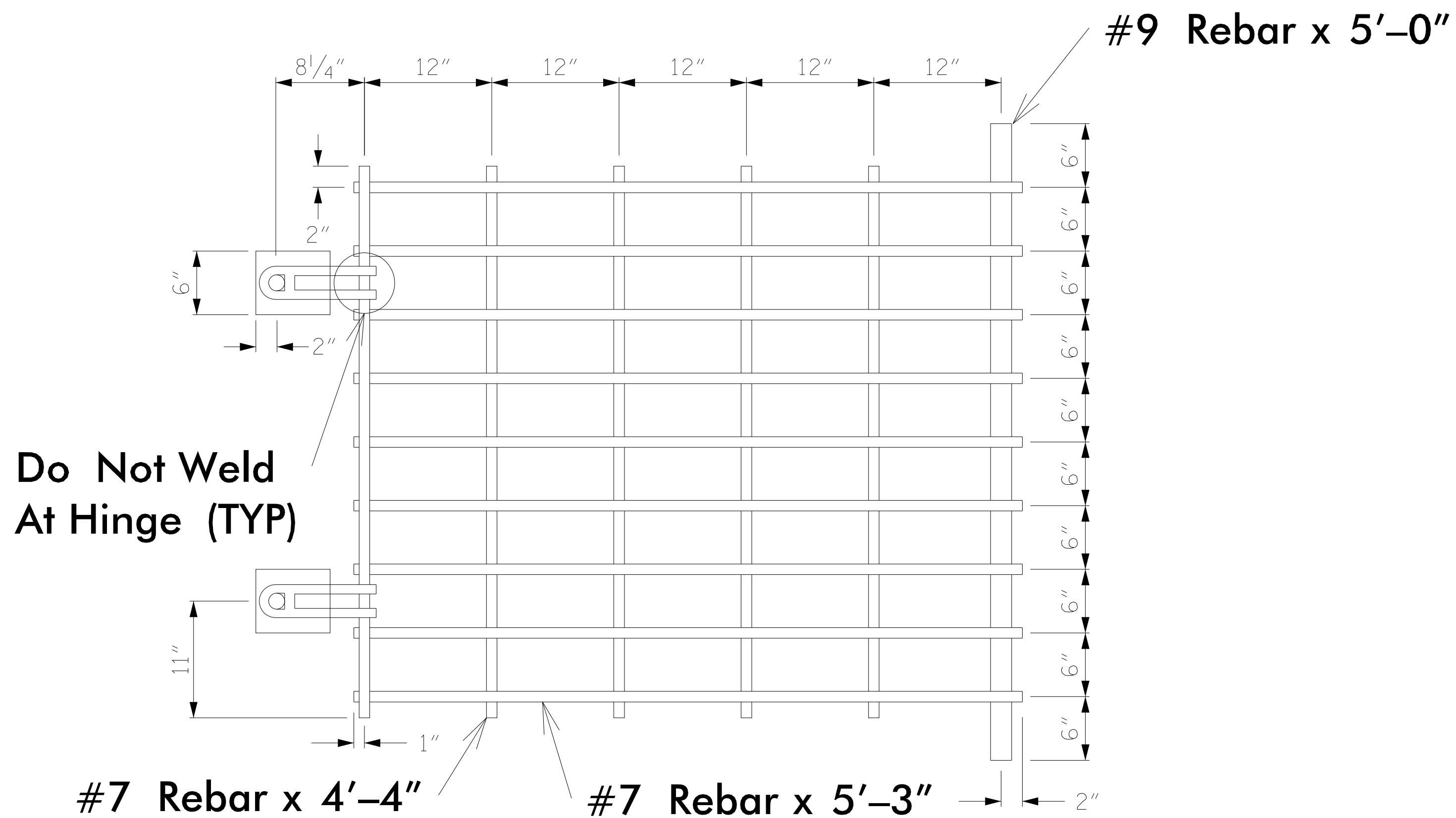
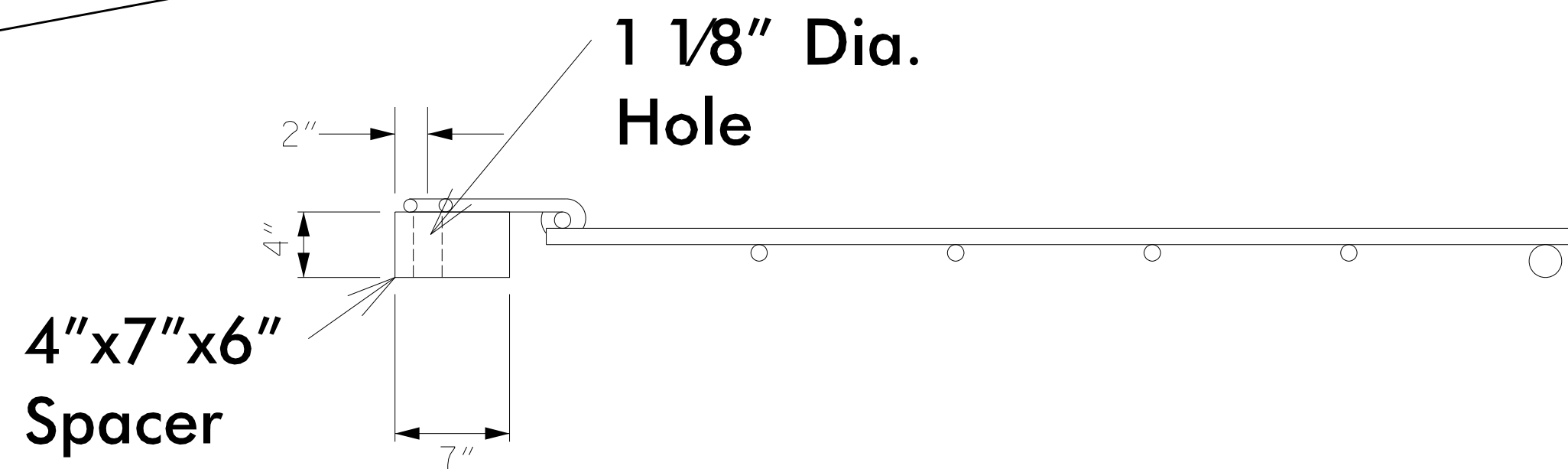

4/7/2021
X:\N6007\1-26 Howard Gap Rd Rehab\Drainage\1-26 Howard Gap_Hydr_Forebay_1.PSH.dgn
User:benegar

FOREBAY #2 -126- 455+20 RT

SHEET 1 OF 2
(NOT TO SCALE)

PROJECT REFERENCE NO. 15614.1075010	SHEET NO. 20-19
RW SHEET NO.	
HYDRAULICS ENGINEER	
DOCUMENT NOT CONSIDERED FINAL UNLESS ALL SIGNATURES COMPLETED	
TGS ENGINEERS 804-C N. LAFAYETTE ST SHELBY, NC 28150 PH (704) 476-0003 CORP. LICENSE NO.: C-0275	

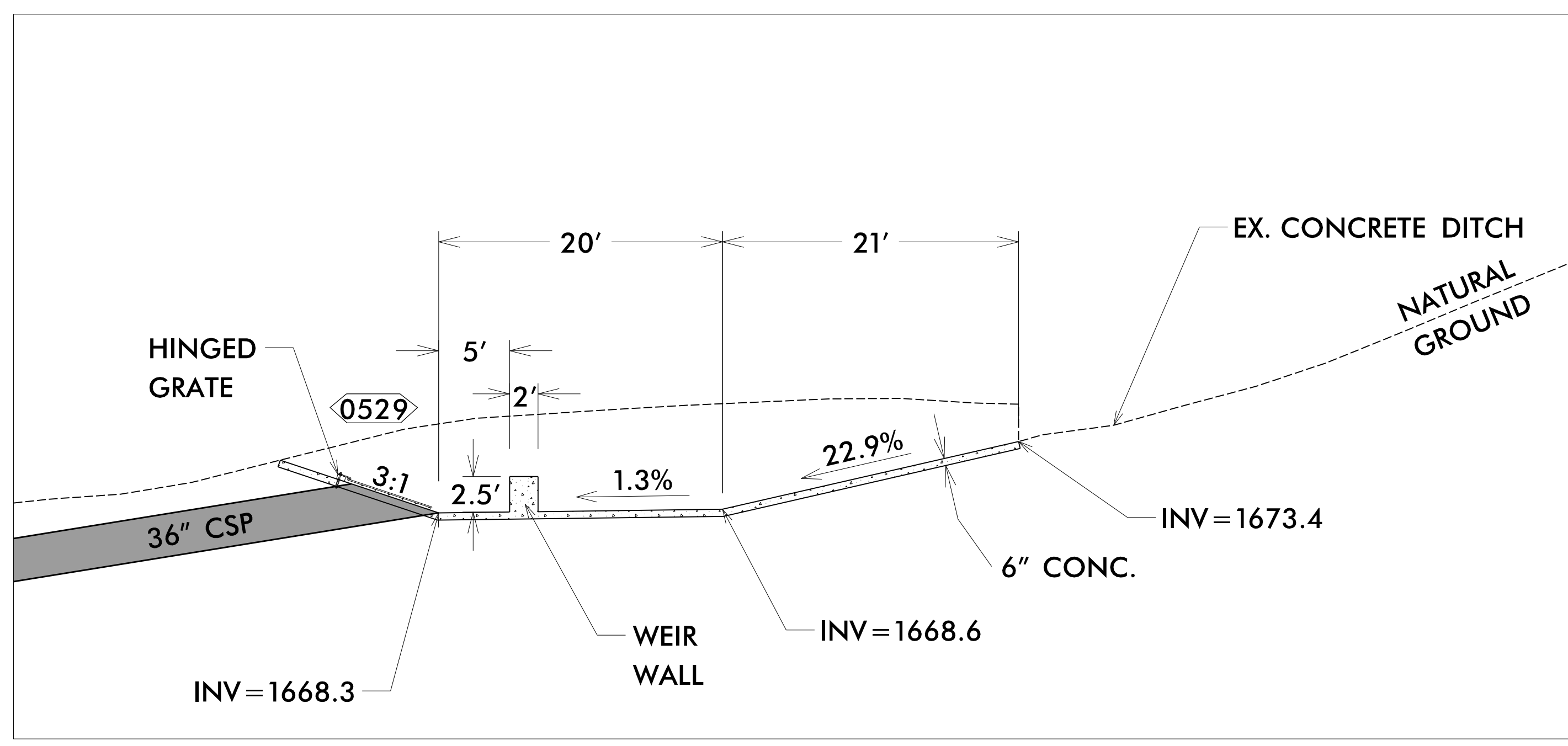

PROFILE VIEW

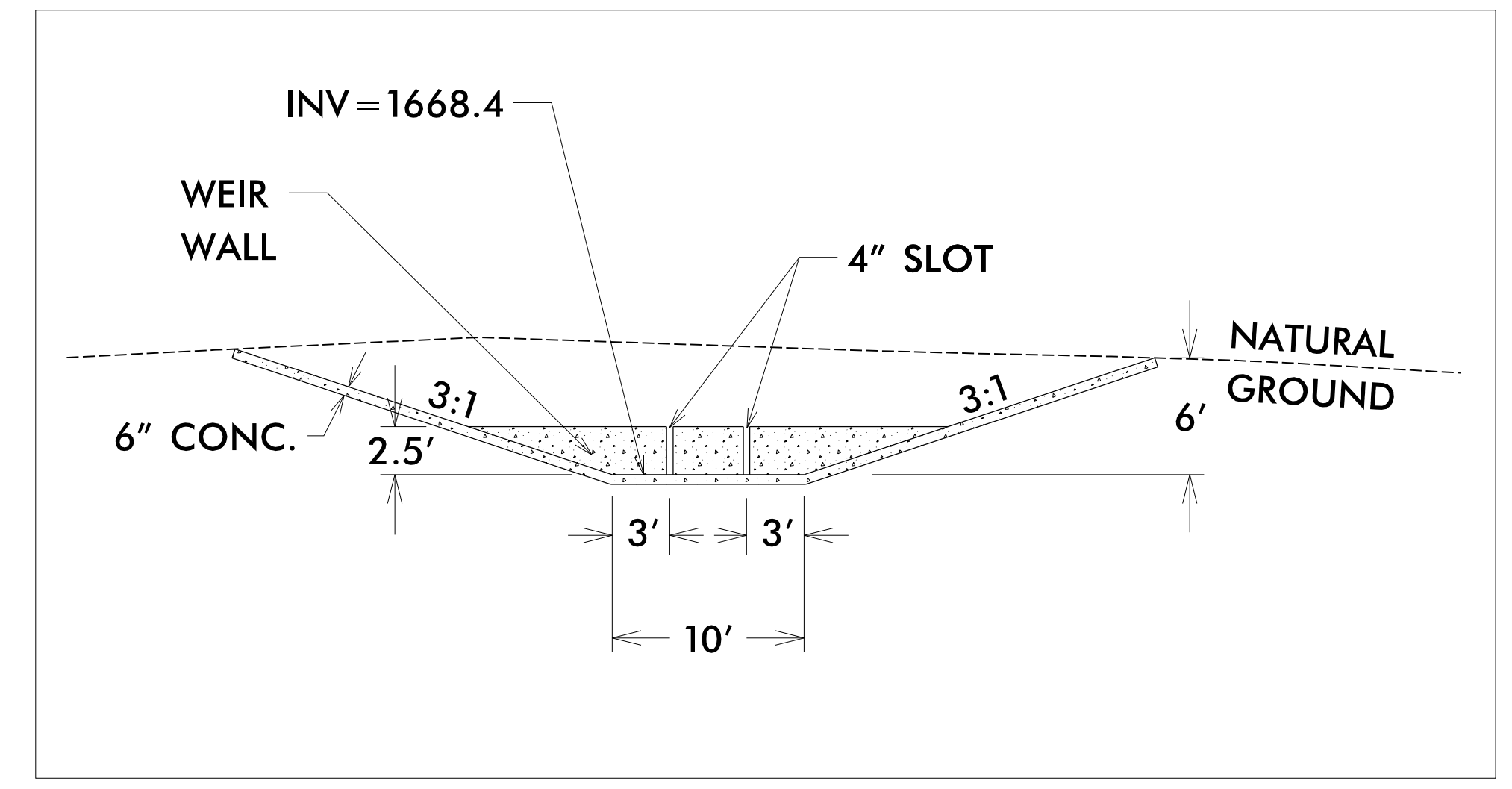

SECTION A-A

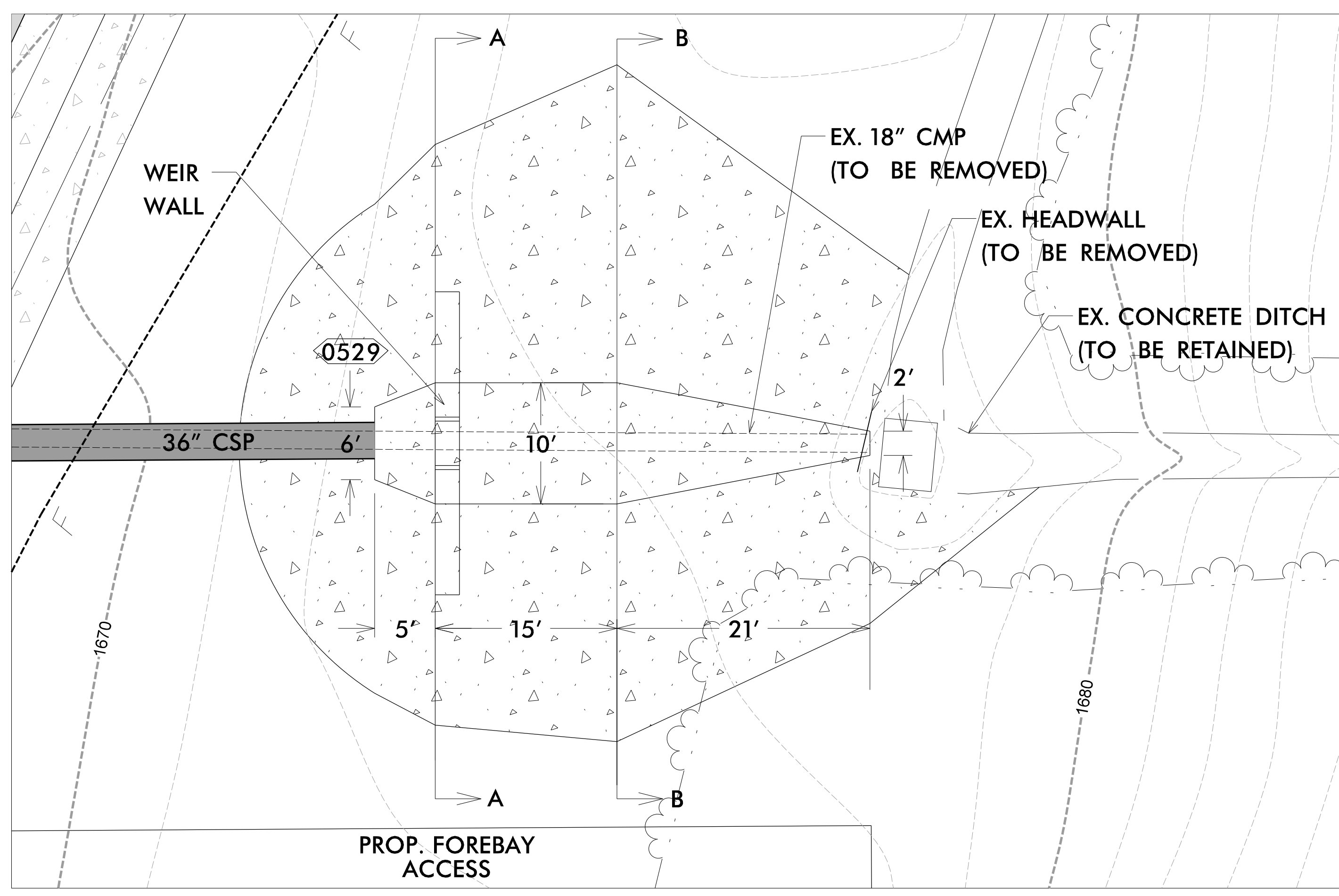

PLAN VIEW

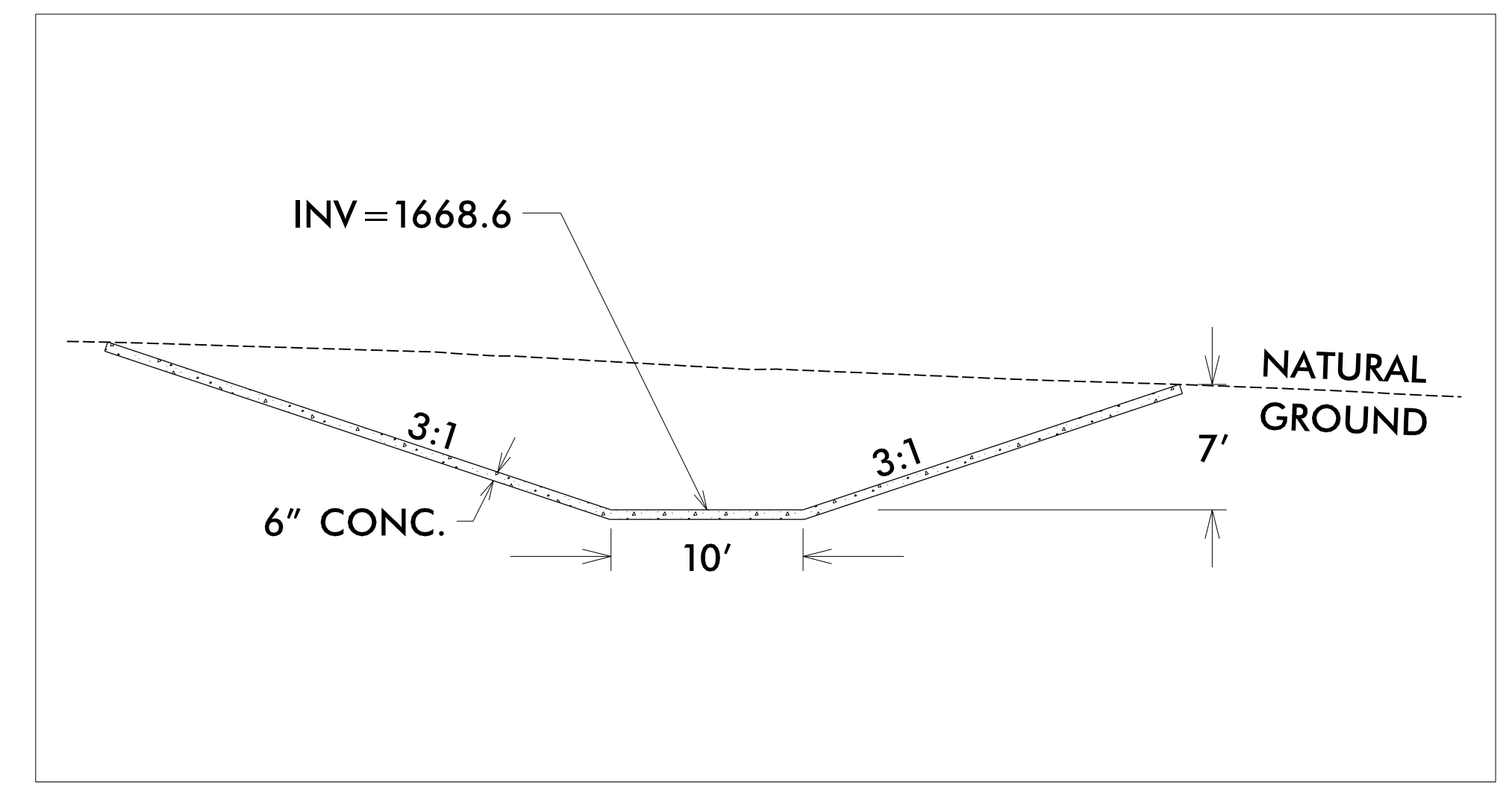

SECTION B-B

8/17/99

FOREBAY #2 -126- 455+20 RT

SHEET 2 OF 2
(NOT TO SCALE)

Hinged Grate

36" Pipe 3:1 Slope

PROJECT REFERENCE NO. 15614.1075010	SHEET NO. 2D-20
R/W SHEET NO.	
HYDRAULICS ENGINEER	
DOCUMENT NOT CONSIDERED FINAL UNLESS ALL SIGNATURES COMPLETED	
TGS ENGINEERS 804-C N. LAFAYETTE ST SHELBY, NC 28150 PH: (704) 476-0003 CORP. LICENSE NO.: C-0275	

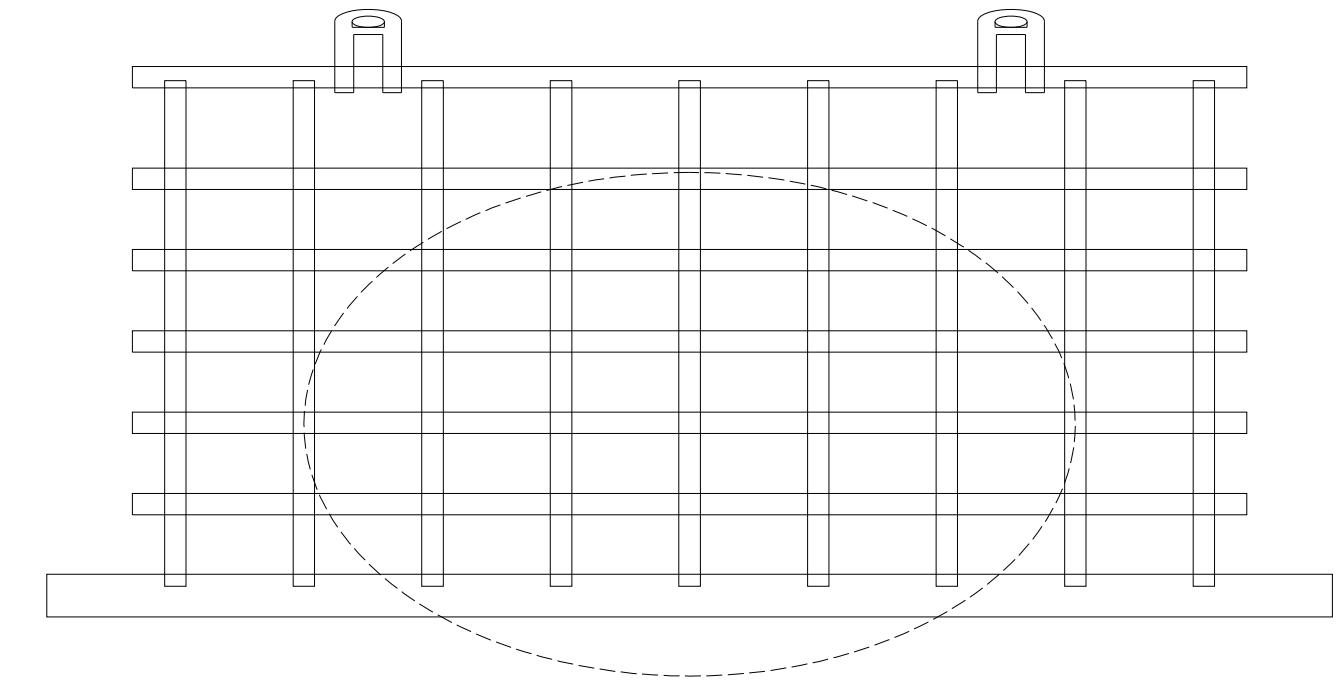
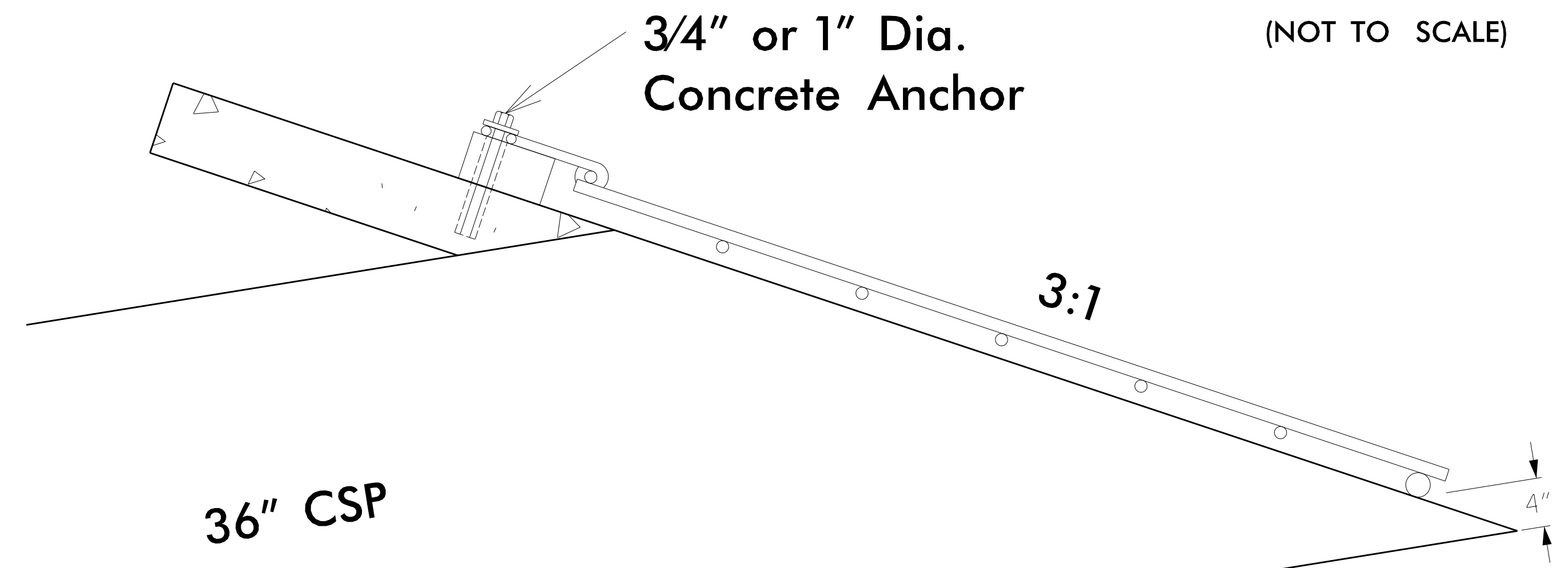

HINGED GRATE NOTES:

1. ALL JOINTS, EXCEPT AS NOTED, SHALL BE FULLY WELDED AROUND JOINT WITH A MINIMUM OF A 1/4" BEAD.
2. GRATE SHALL BE REBAR AND GALVANIZED IN ACCORDANCE WITH ASTM A-153.
3. SPACER SHALL CONFORM TO AASHTO M270 GRADE 36. AFTER FABRICATION, HOT-DIP GALVANIZE SPACER IN ACCORDANCE WITH AASHTO M111.
4. USE CONCRETE ANCHORS CONSISTING OF A STUD BOLT WITH NUT AND WASHER. USE STUDS THREADED ON ONE END AND HAVING AN EXPANDED WEDGE ASSEMBLY POSITIONED AROUND A TAPERED AREA AT THE OTHER END. USE ANCHORS WHICH PROVIDE A MINIMUM SAFE HOLDING POWER OF 2875 LBS. FOR A 3/4" OR 1" DIAMETER BOLT. CALCULATE HOLDING POWER BASED ON 1/4 THE ACTUAL HOLDING POWER OF THE ANCHOR IN 3500 PSI CONCRETE AS DETERMINED BY AN APPROVED COMMERCIAL TESTING LABORATORY.
5. USE ANCHORS GALVANIZED IN ACCORDANCE WITH ASTM A-153. SIZE HOLES FOR THE CONCRETE ANCHORS IN ACCORDANCE WITH THE ANCHOR MANUFACTURER'S RECOMMENDATIONS. DRILL HOLES WITH A CARBIDE OR DIAMOND TIPPED MASONRY BIT POWERED BY A ROTARY OR ROTARY IMPACT DRILL. NO OTHER IMPACT TOOLS WILL BE PERMITTED. DRILL HOLES VERTICALLY. FURNISH DOCUMENTATION OF HOLE SIZE RECOMMENDED FOR THE SPECIFIED ANCHOR TO THE ENGINEER BEFORE DRILLING HOLES. THOROUGHLY CLEAN HOLES FOR ANCHORS OF ALL CONCRETE CHIPS, DUST, GREASE, OIL, ETC. BEFORE ANCHORS ARE INSTALLED. REPAIR ALL DAMAGE CAUSED BY THIS WORK TO THE SATISFACTION OF THE ENGINEER.
6. FOR HINGED GRATE, SEE SPECIAL PROVISIONS.

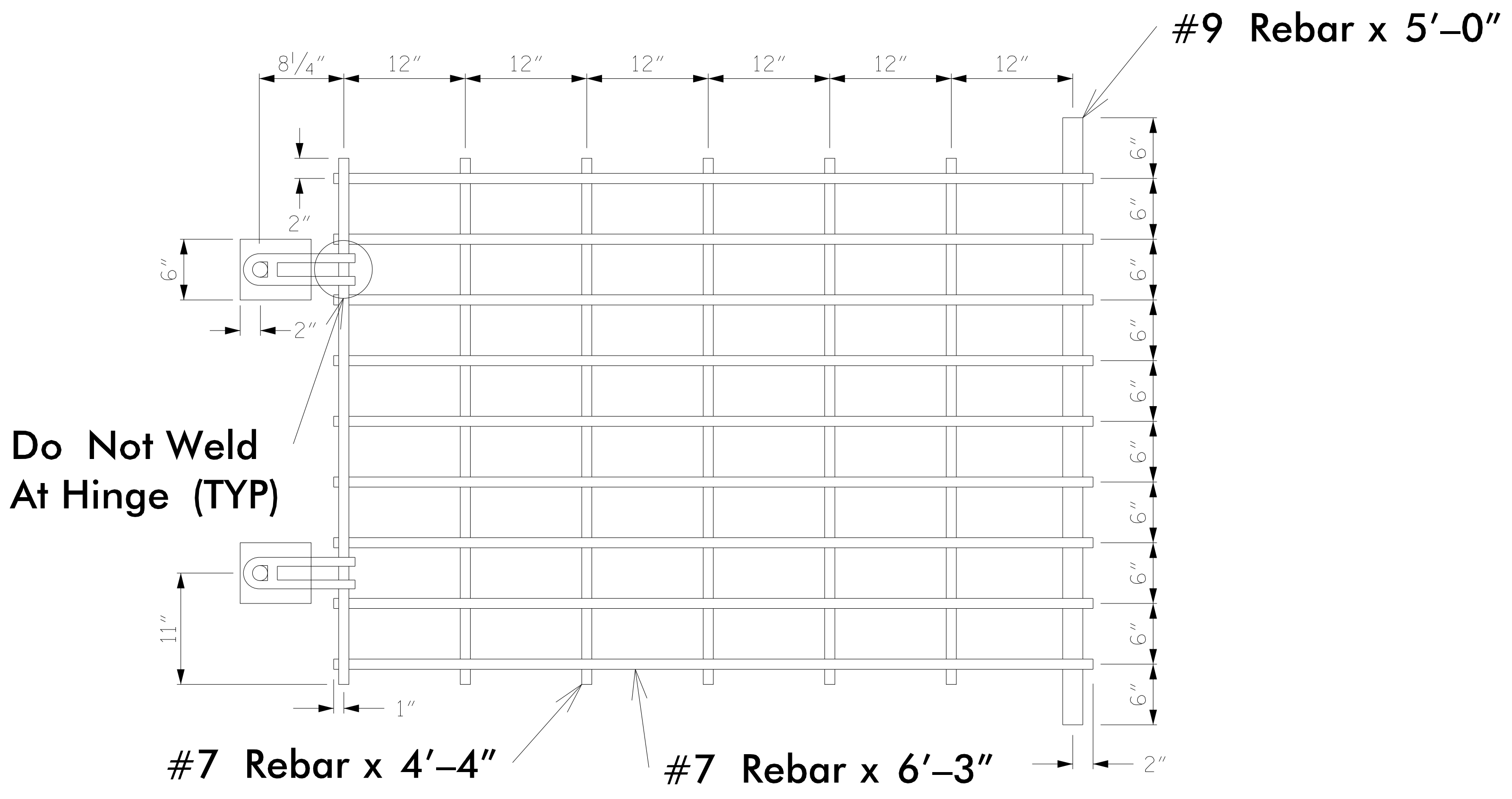
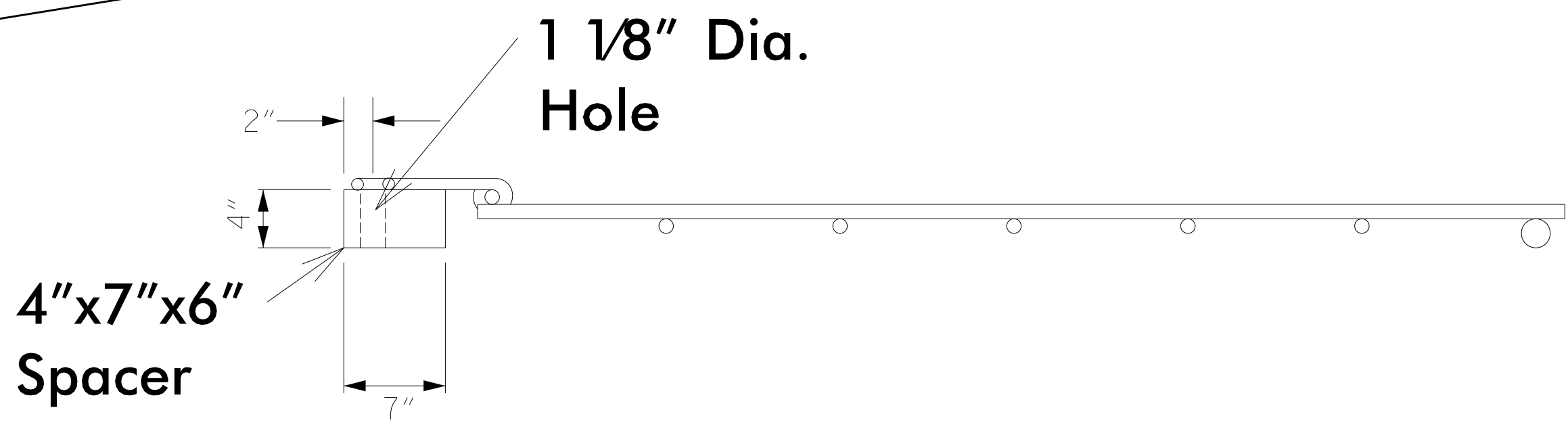

4/7/2021
X:\NG006\1-26 Howard Gap Rd Rehab\Drainage\1-26 Howards Gap_Hydr_Hydr_Forebay_2_PSH.dgn
User: bhenegar

8/17/19

FOREBAY #3 -126- 463+30 RT

SHEET 1 OF 3
(NOT TO SCALE)

PROJECT REFERENCE NO. 15614.1075010	SHEET NO. 20-21
RW SHEET NO.	
HYDRAULICS ENGINEER	
DOCUMENT NOT CONSIDERED FINAL UNLESS ALL SIGNATURES COMPLETED	
TGS ENGINEERS 804-C N. LAFAYETTE ST SHELBY, NC 28150 PH (704) 476-0003 CORP. LICENSE NO.: C-0275	

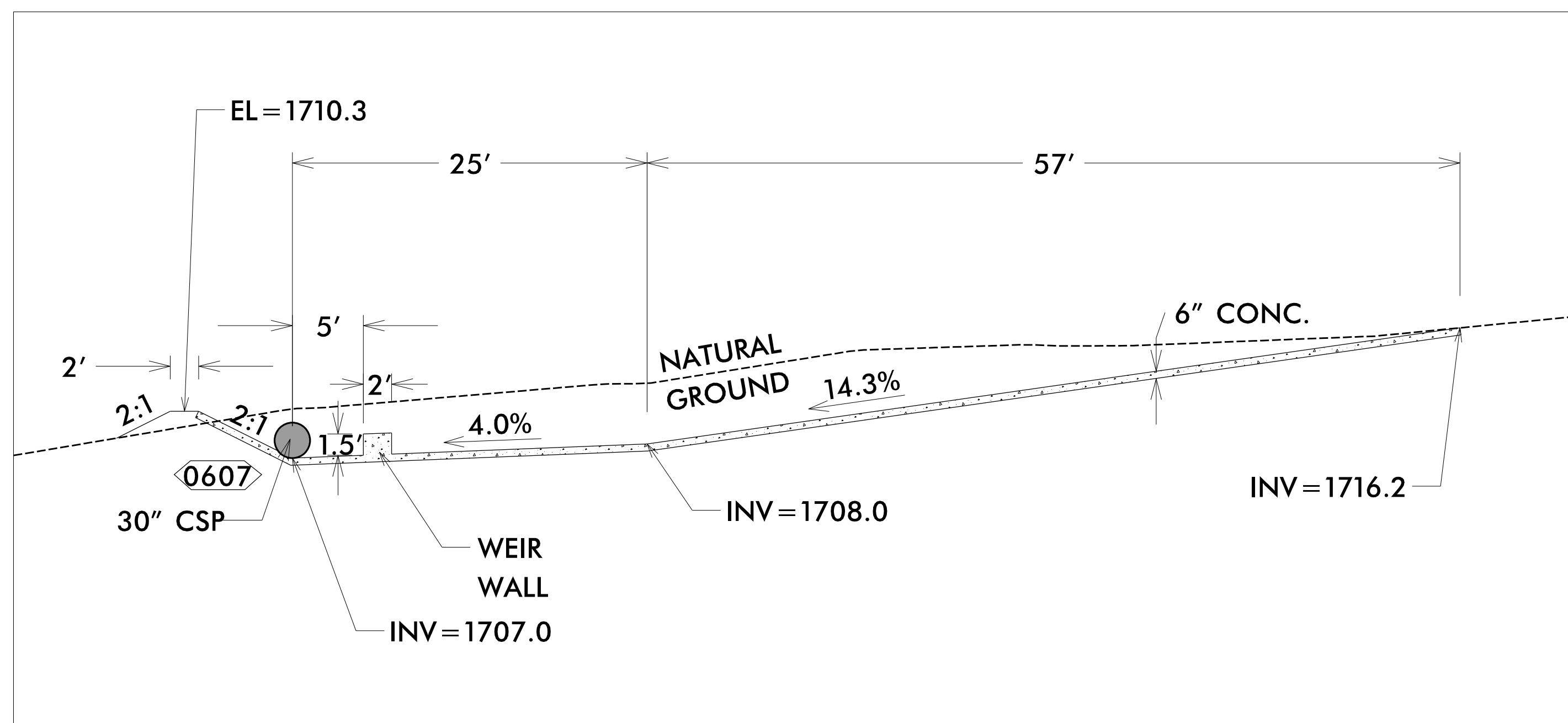

PROFILE VIEW

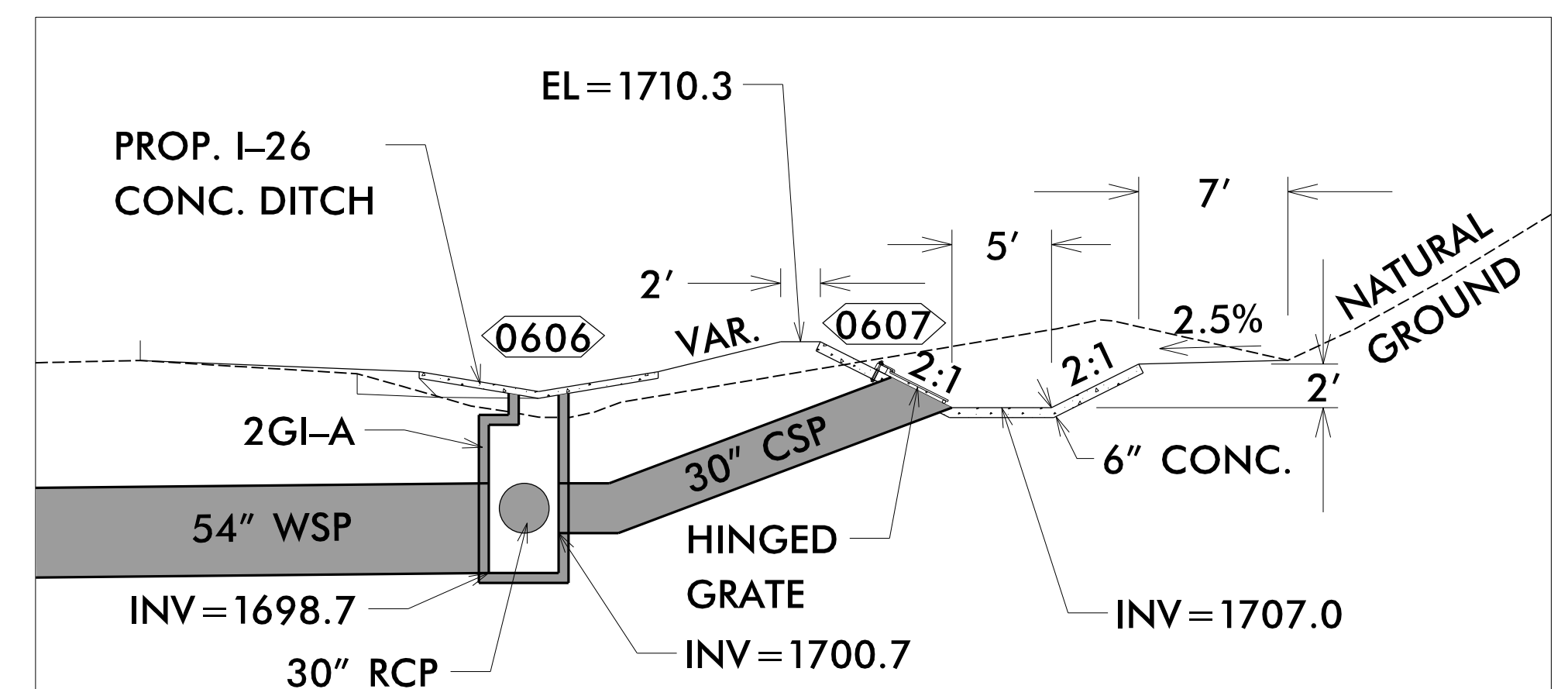

SECTION A-A

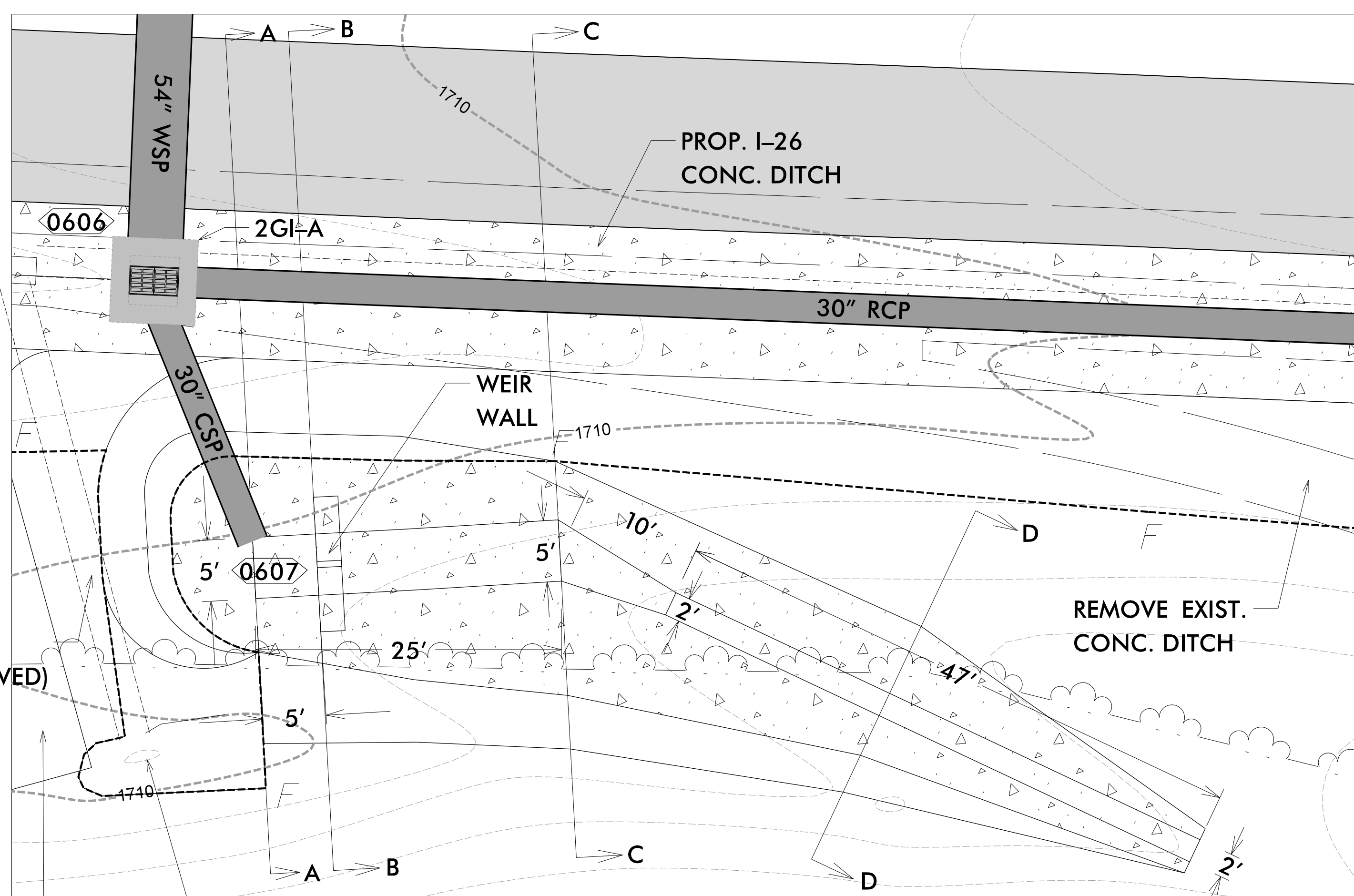

PLAN VIEW

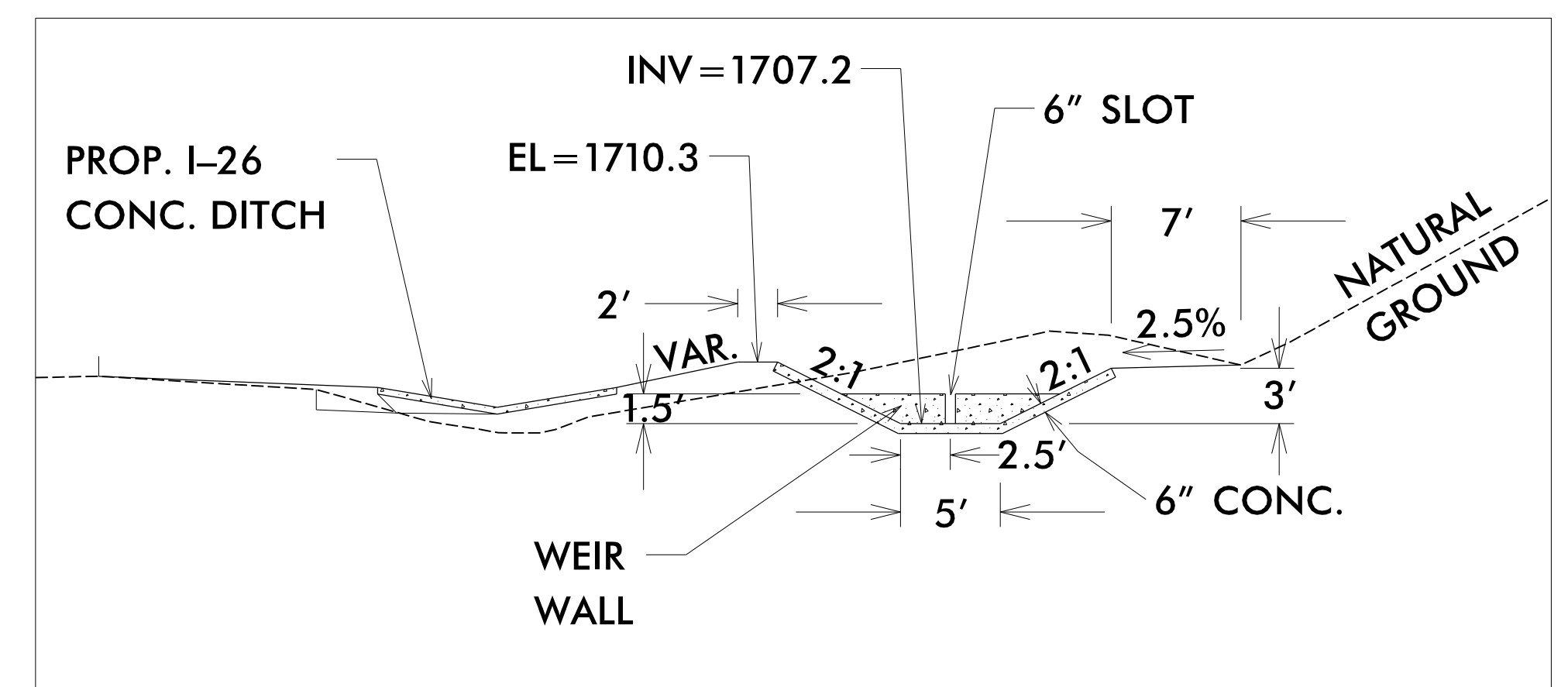

SECTION B-B

EX. 30" CMP
(TO BE REMOVED)

FILL EXIST. DITCH
AT EXIST. PIPE INLET

PROP. FOREBAY
ACCESS

4/7/2021
X:\N0606\1-26 Howard Gap Rd Rehab\Drainage\1-26 Howard Gap_Hydr\Forebay_3_PSH.dgn
User:benegar

8/17/99

FOREBAY #3 -126- 463+30 RT

SHEET 2 OF 3
(NOT TO SCALE)

PROJECT REFERENCE NO. 15614.1075010	SHEET NO. 2D-22
RW SHEET NO.	
HYDRAULICS ENGINEER	
DOCUMENT NOT CONSIDERED FINAL UNLESS ALL SIGNATURES COMPLETED	
	TGS ENGINEERS 804-C N. LAFAYETTE ST SHELBY, NC 28150 PH (704) 476-0003 CORP. LICENSE NO.: C-0275

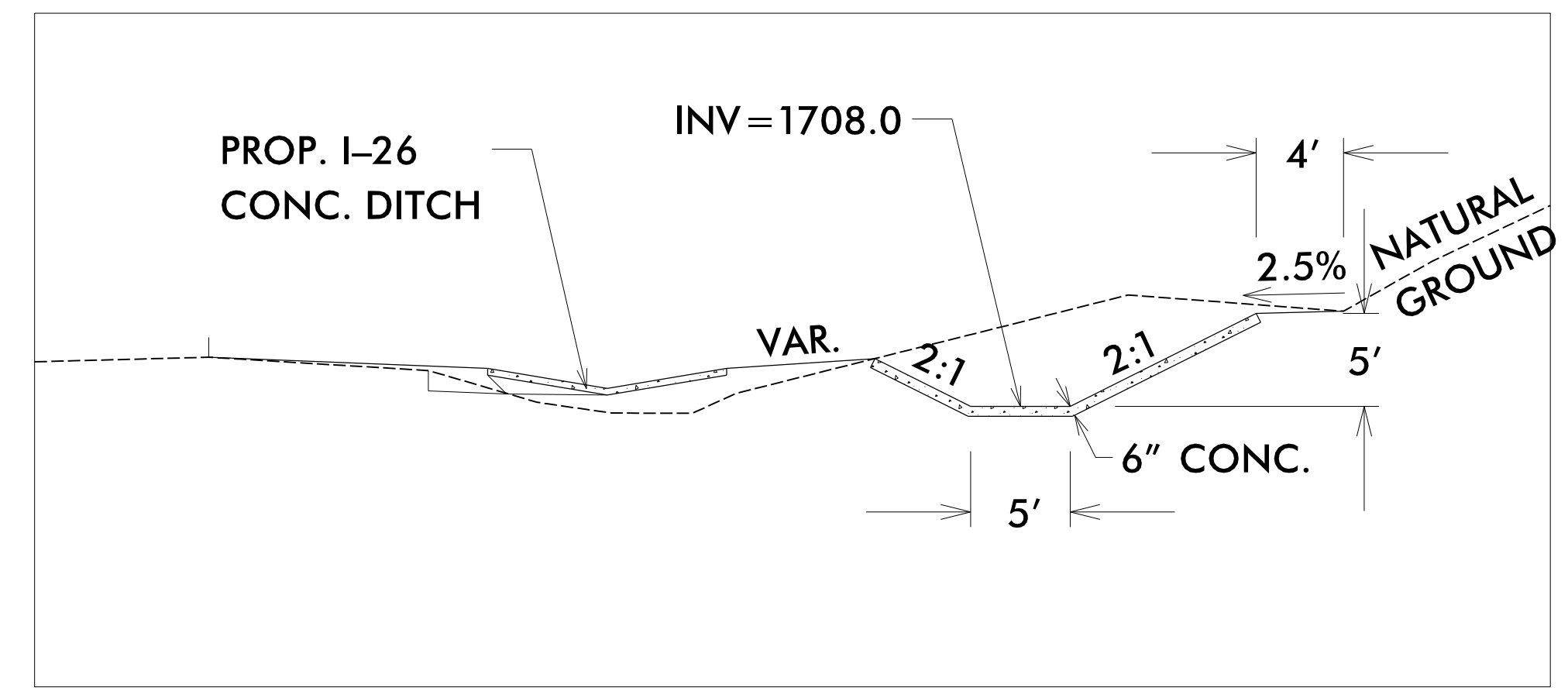

SECTION C-C

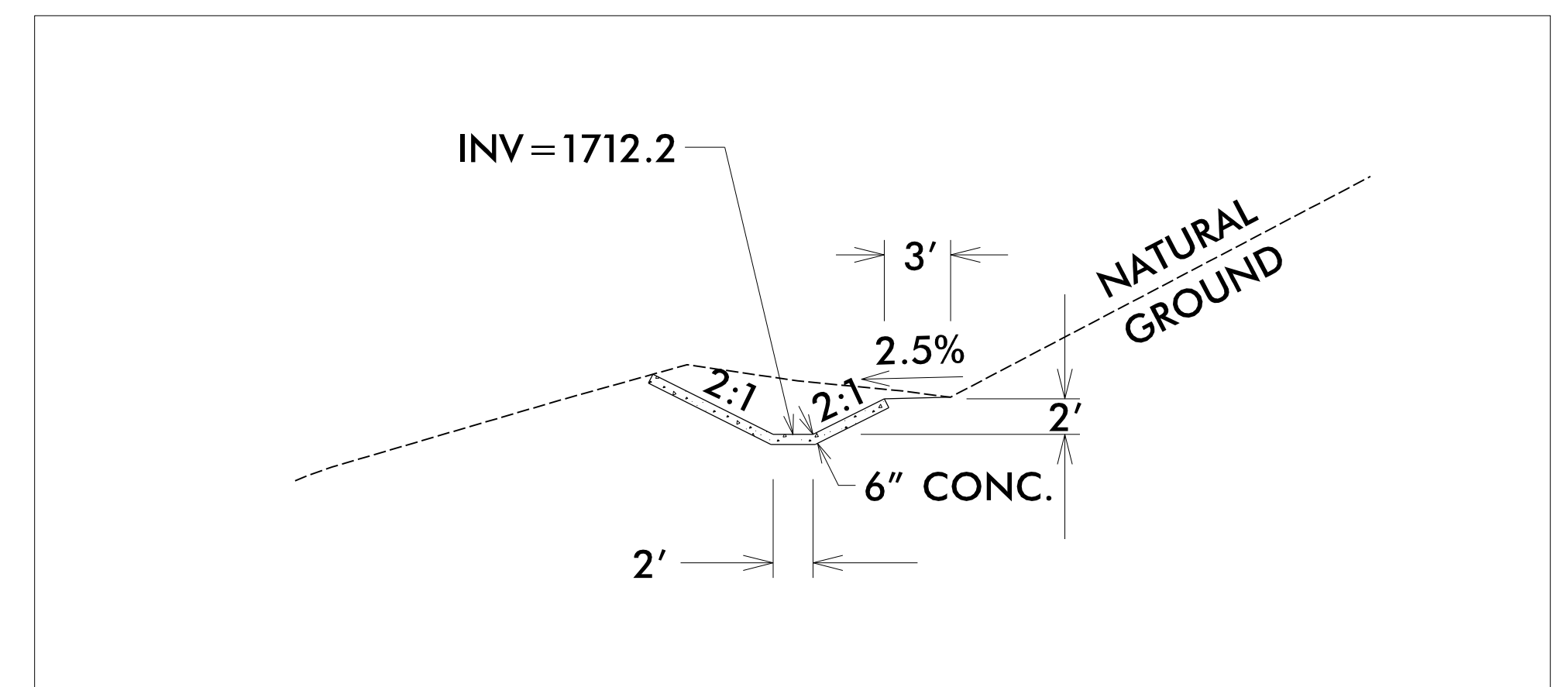

SECTION D-D

4/7/2021
X:\NC\067\I-26 Howard Gap Rd Rehab\Drainage\I-26 Howards Gap_Hydr_Forebay_3_PSH.dgn
User:benegar

8/17/99

FOREBAY #3 -126- 463+30 RT

SHEET 3 OF 3
(NOT TO SCALE)

Hinged Grate

30" Pipe 2:1 Slope

PROJECT REFERENCE NO. 15614.1075010	SHEET NO. 2D-23
R/W SHEET NO.	
HYDRAULICS ENGINEER	
DOCUMENT NOT CONSIDERED FINAL UNLESS ALL SIGNATURES COMPLETED	
TGS ENGINEERS 804-C N. LAFAYETTE ST SHELBY, NC 28150 PH (704) 476-0003 CORP. LICENSE NO.: C-0275	

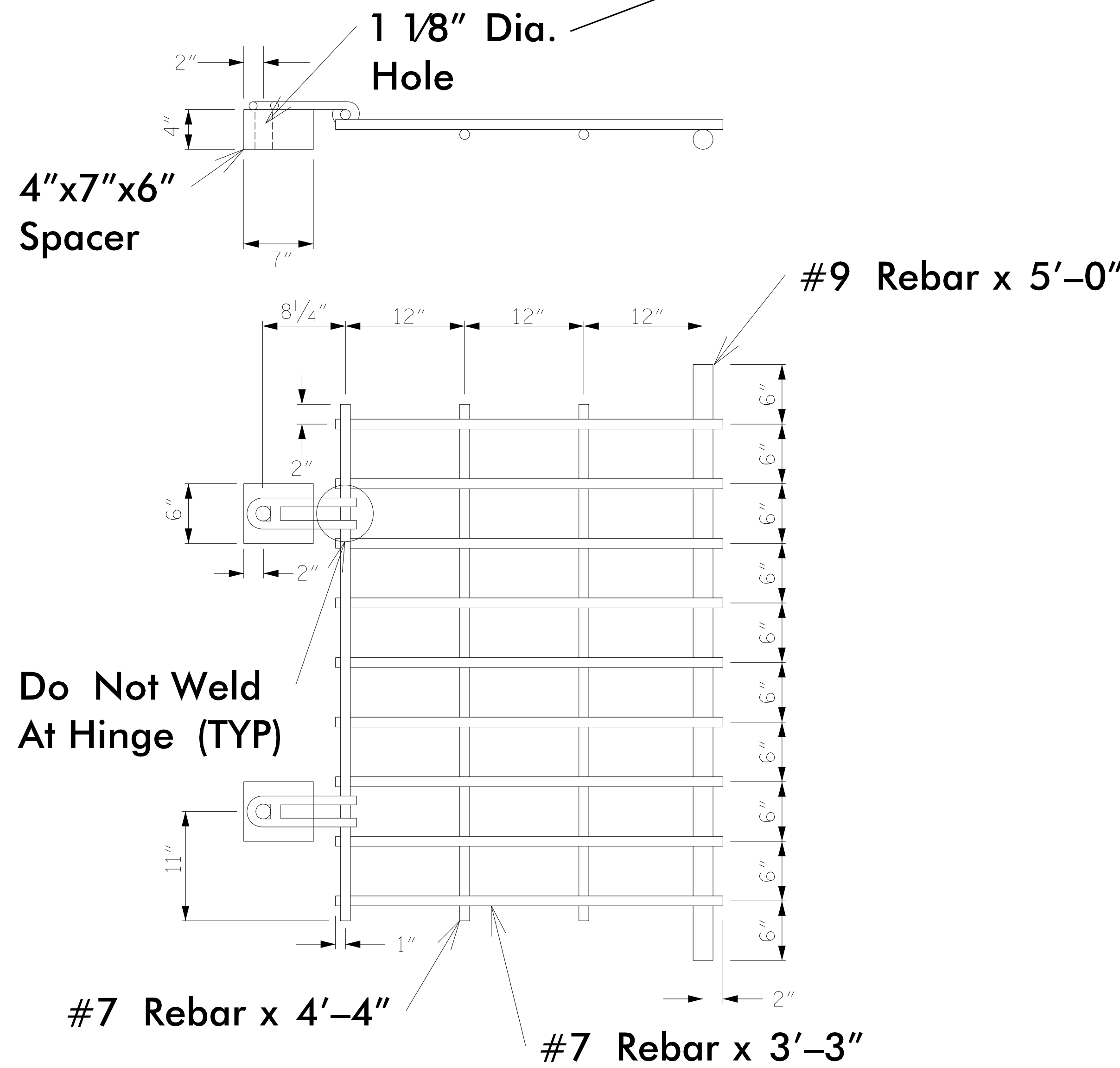
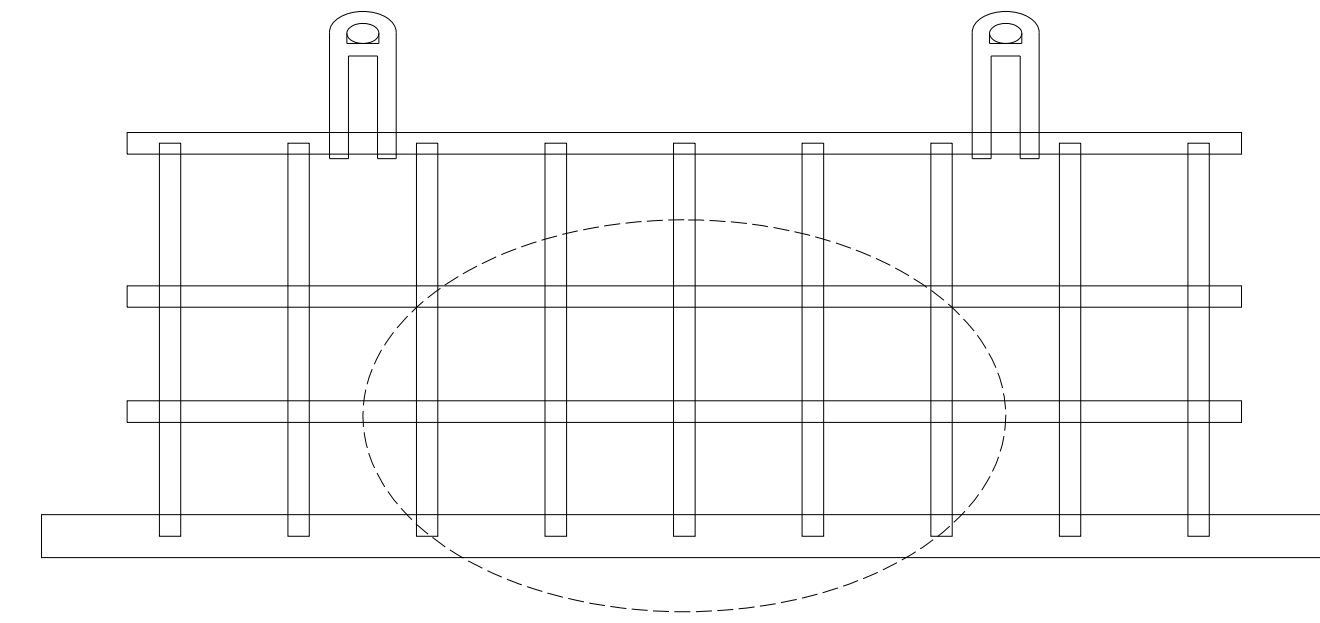
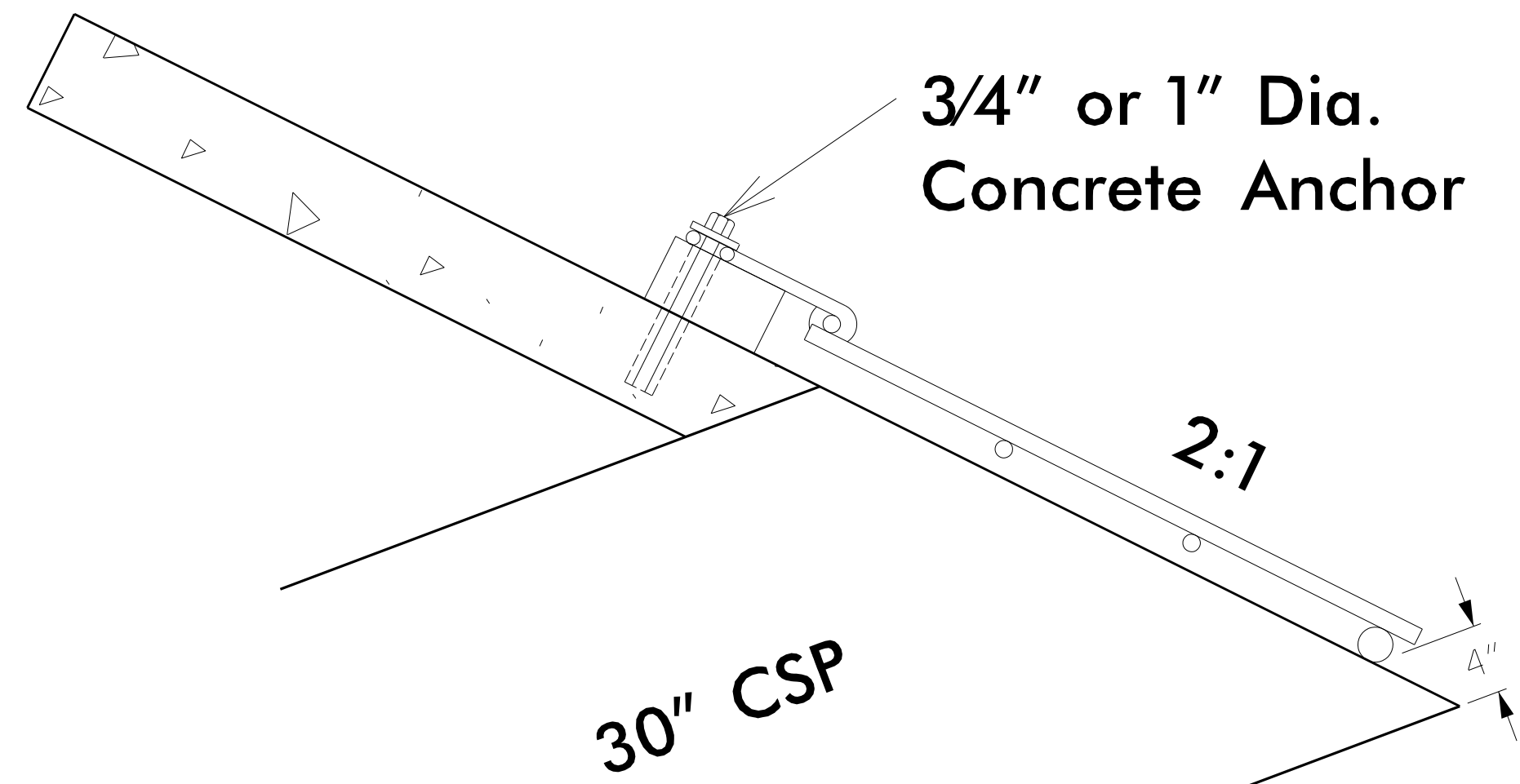

HINGED GRATE NOTES:

- ALL JOINTS, EXCEPT AS NOTED, SHALL BE FULLY WELDED AROUND JOINT WITH A MINIMUM OF A 1/4" BEAD.
- GRATE SHALL BE REBAR AND GALVANIZED IN ACCORDANCE WITH ASTM A-153.
- SPACER SHALL CONFORM TO AASHTO M270 GRADE 36. AFTER FABRICATION, HOT-DIP GALVANIZE SPACER IN ACCORDANCE WITH AASHTO M111.
- USE CONCRETE ANCHORS CONSISTING OF A STUD BOLT WITH NUT AND WASHER. USE STUDS THREADED ON ONE END AND HAVING AN EXPANDED WEDGE ASSEMBLY POSITIONED AROUND A TAPERED AREA AT THE OTHER END. USE ANCHORS WHICH PROVIDE A MINIMUM SAFE HOLDING POWER OF 2875 LBS. FOR A 3/4" OR 1" DIAMETER BOLT. CALCULATE HOLDING POWER BASED ON 1/4 THE ACTUAL HOLDING POWER OF THE ANCHOR IN 3500 PSI CONCRETE AS DETERMINED BY AN APPROVED COMMERCIAL TESTING LABORATORY.
- USE ANCHORS GALVANIZED IN ACCORDANCE WITH ASTM A-153. SIZE HOLES FOR THE CONCRETE ANCHORS IN ACCORDANCE WITH THE ANCHOR MANUFACTURER'S RECOMMENDATIONS. DRILL HOLES WITH A CARBIDE OR DIAMOND TIPPED MASONRY BIT POWERED BY A ROTARY OR ROTARY IMPACT DRILL. NO OTHER IMPACT TOOLS WILL BE PERMITTED. DRILL HOLES VERTICALLY. FURNISH DOCUMENTATION OF HOLE SIZE RECOMMENDED FOR THE SPECIFIED ANCHOR TO THE ENGINEER BEFORE DRILLING HOLES. THOROUGHLY CLEAN HOLES FOR ANCHORS OF ALL CONCRETE CHIPS, DUST, GREASE, OIL, ETC. BEFORE ANCHORS ARE INSTALLED. REPAIR ALL DAMAGE CAUSED BY THIS WORK TO THE SATISFACTION OF THE ENGINEER.
- FOR HINGED GRATE, SEE SPECIAL PROVISIONS.

4/7/2021
X:\NG006\1-26 Howard Gap Rd Rehab\Drainage\1-26 Howard Gap_Hydr\Forebay_3_PSH.dgn
User:benegar

8/17/19

FOREBAY #4 -126- 470+65 RT

SHEET 1 OF 3
(NOT TO SCALE)

PROJECT REFERENCE NO. 156141075010	SHEET NO. 2D-24
RW SHEET NO.	
HYDRAULICS ENGINEER	
DOCUMENT NOT CONSIDERED FINAL UNLESS ALL SIGNATURES COMPLETED	
TGS ENGINEERS 804-C N. LAFAYETTE ST SHELBY, NC 28150 PH: (704) 476-0003 CORP. LICENSE NO.: C-0275	

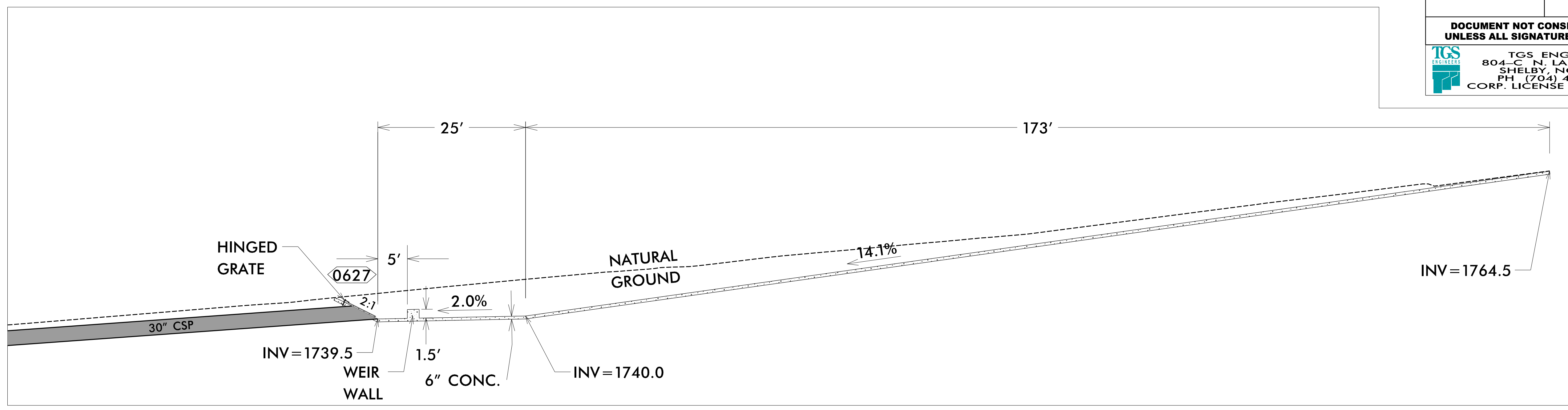

PROFILE VIEW

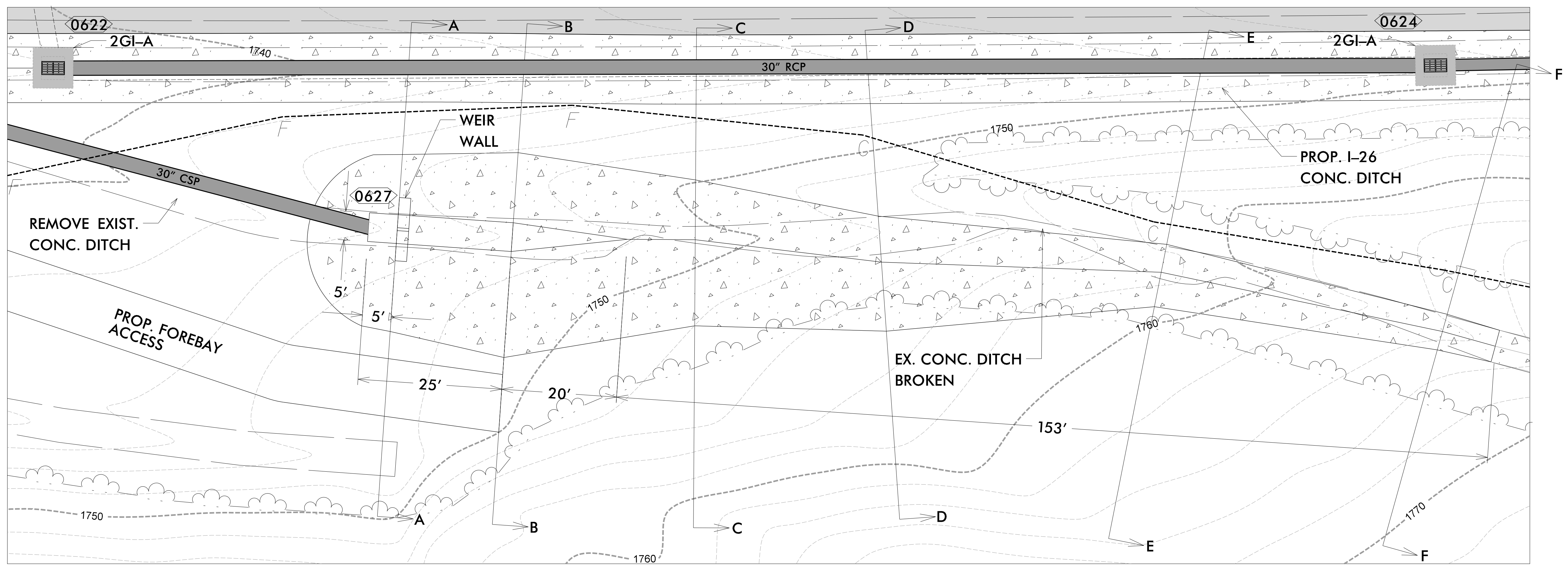

PLAN VIEW

4/7/2021
X:\N06061\I-26 Howard Gap Rd Rehab\Drainage\I-26 Howard Gap_Hydr\Forebay_4_PSH.dgn
User:benegar

8/17/99

FOREBAY #4 -126- 470+65 RT

SHEET 2 OF 3
(NOT TO SCALE)

PROJECT REFERENCE NO. 15614.1075010	SHEET NO. 2D-25
RW SHEET NO.	
HYDRAULICS ENGINEER	
DOCUMENT NOT CONSIDERED FINAL UNLESS ALL SIGNATURES COMPLETED	
TGS ENGINEERS 804-C N. LAFAYETTE ST SHELBY, NC 28150 PH (704) 476-0003 CORP. LICENSE NO.: C-0275	

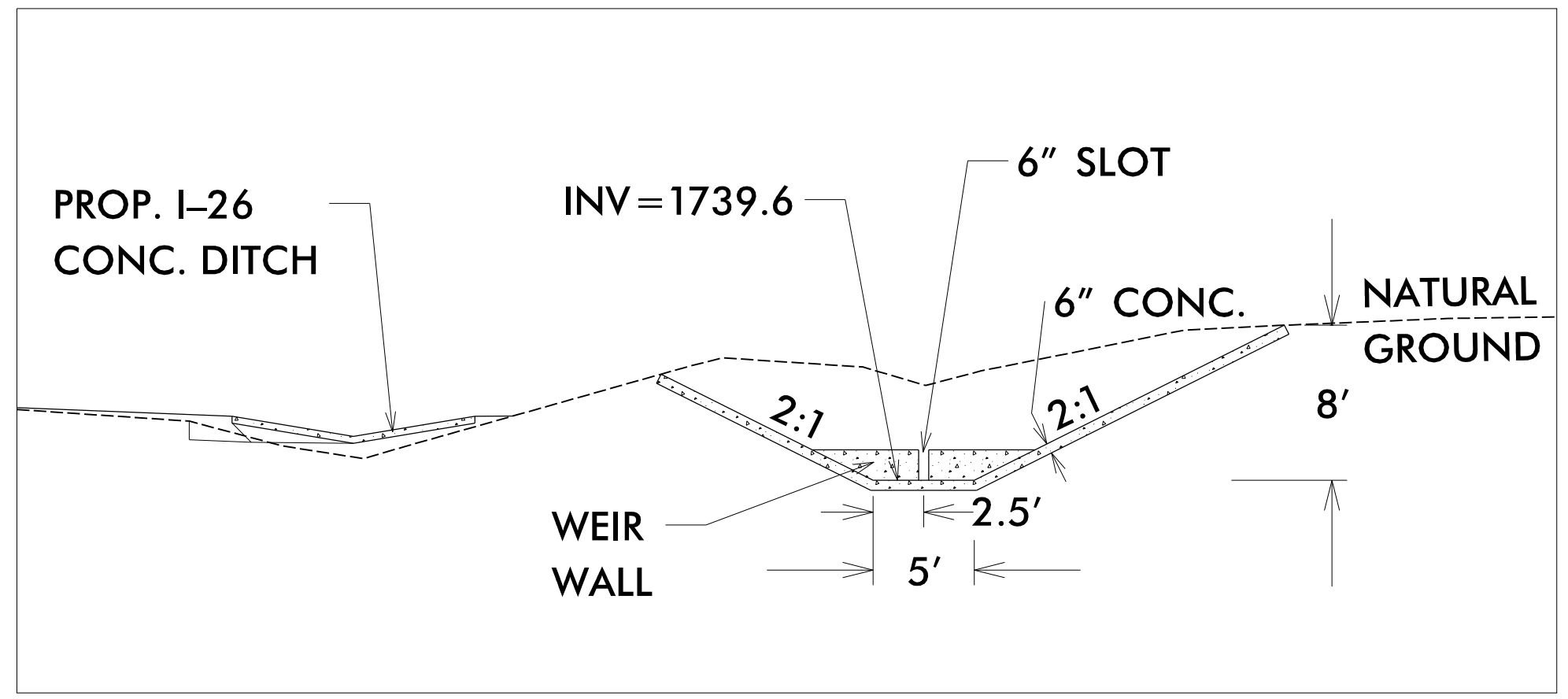

SECTION A-A

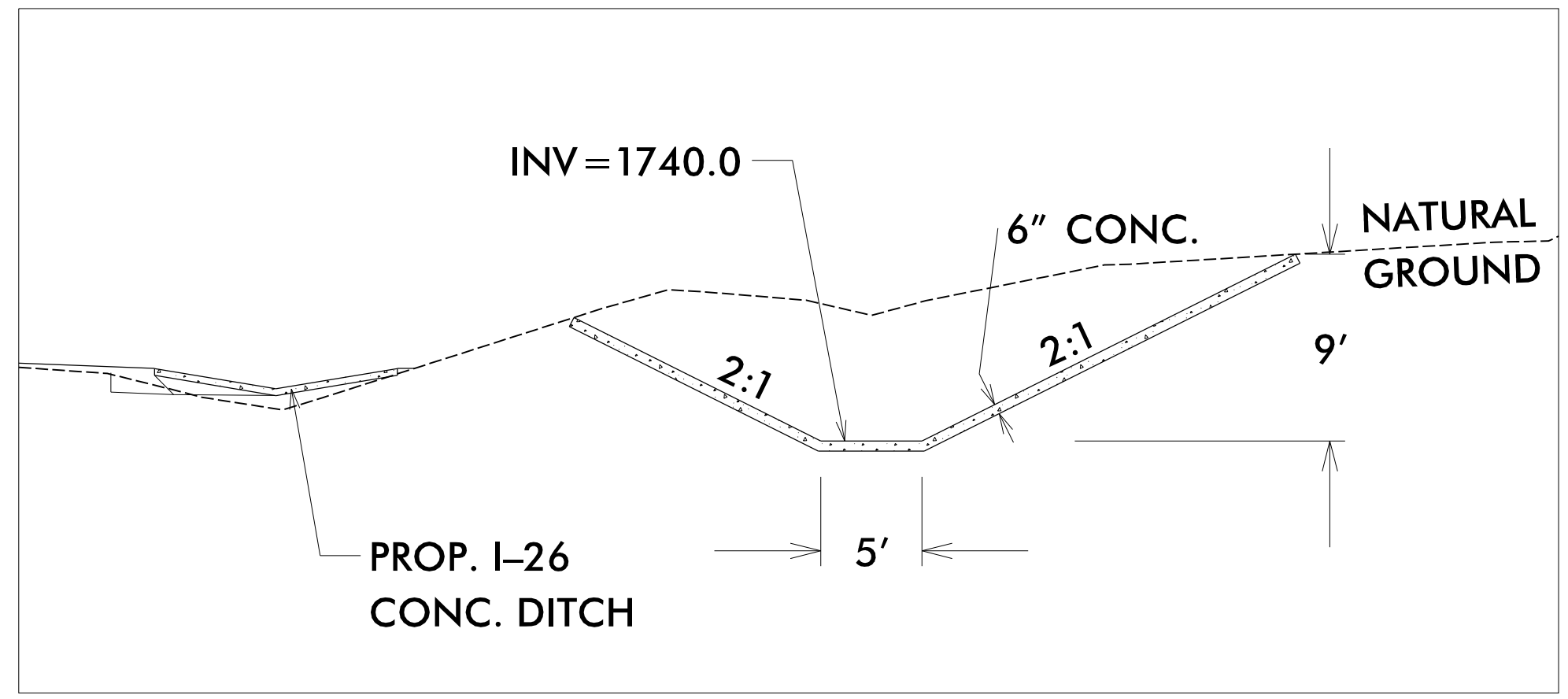

SECTION B-B

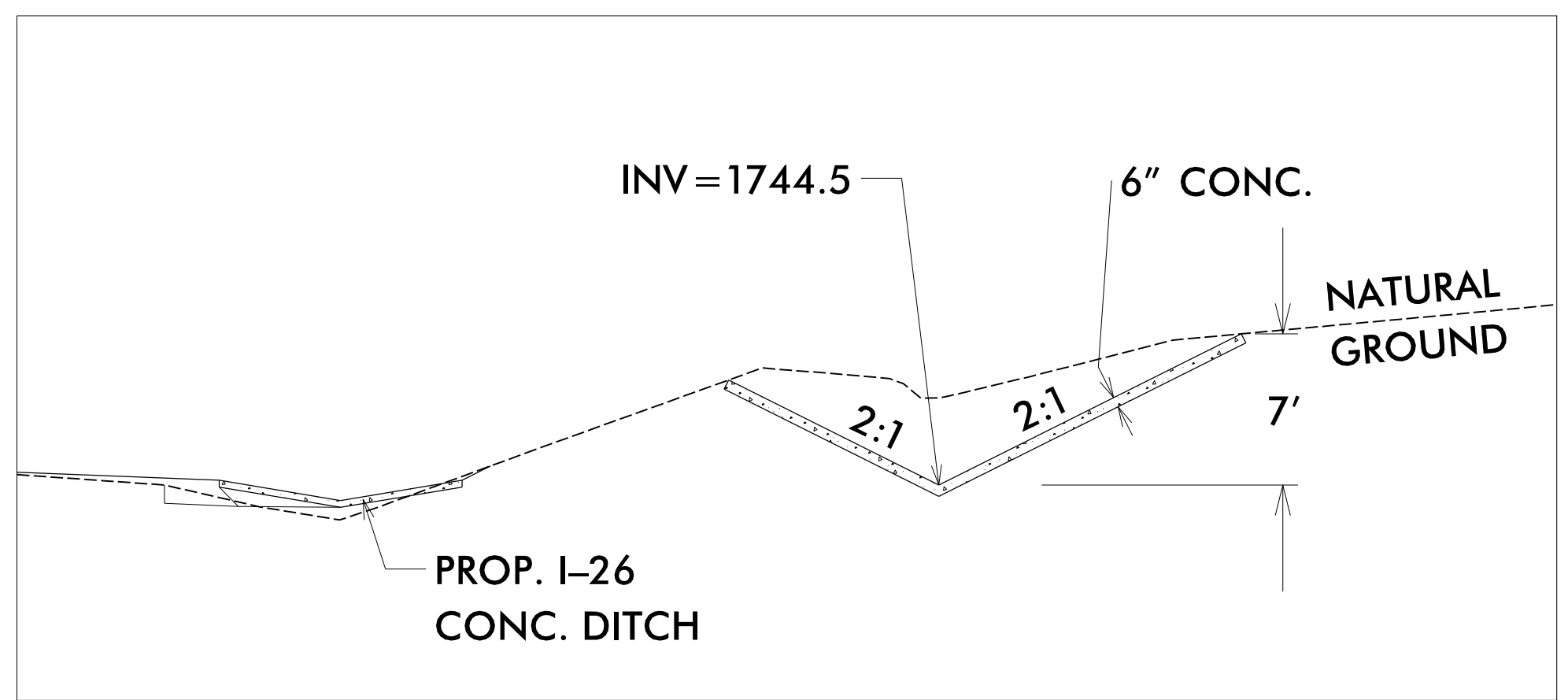

SECTION C-C

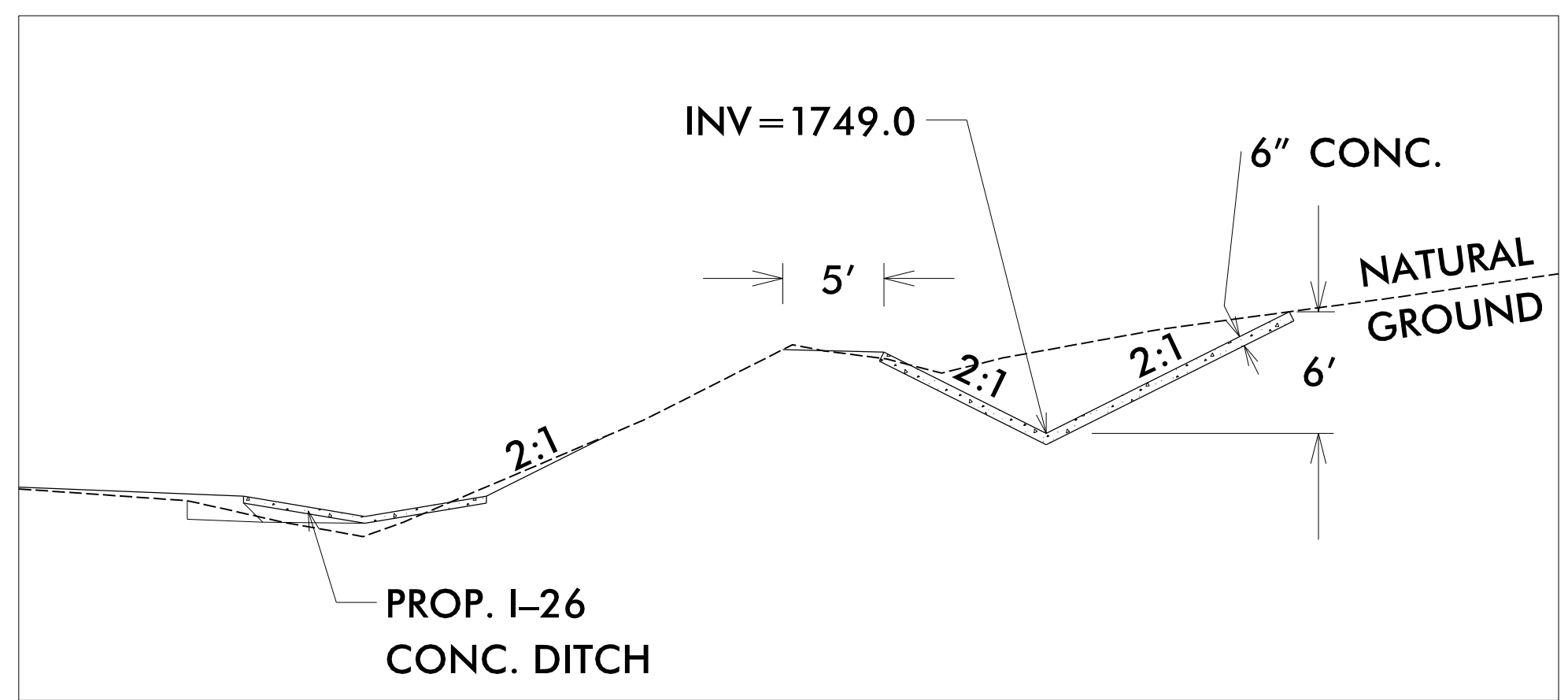

SECTION D-D

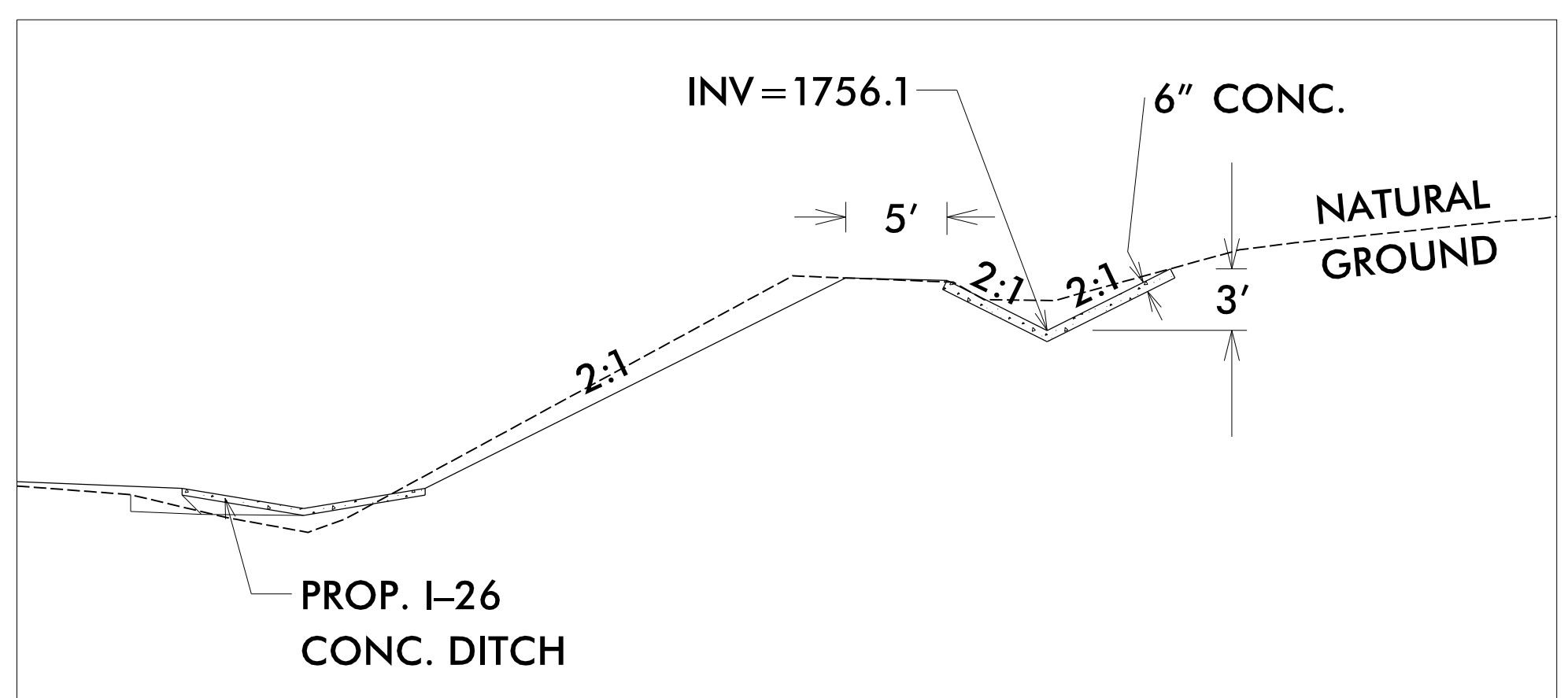

SECTION E-E

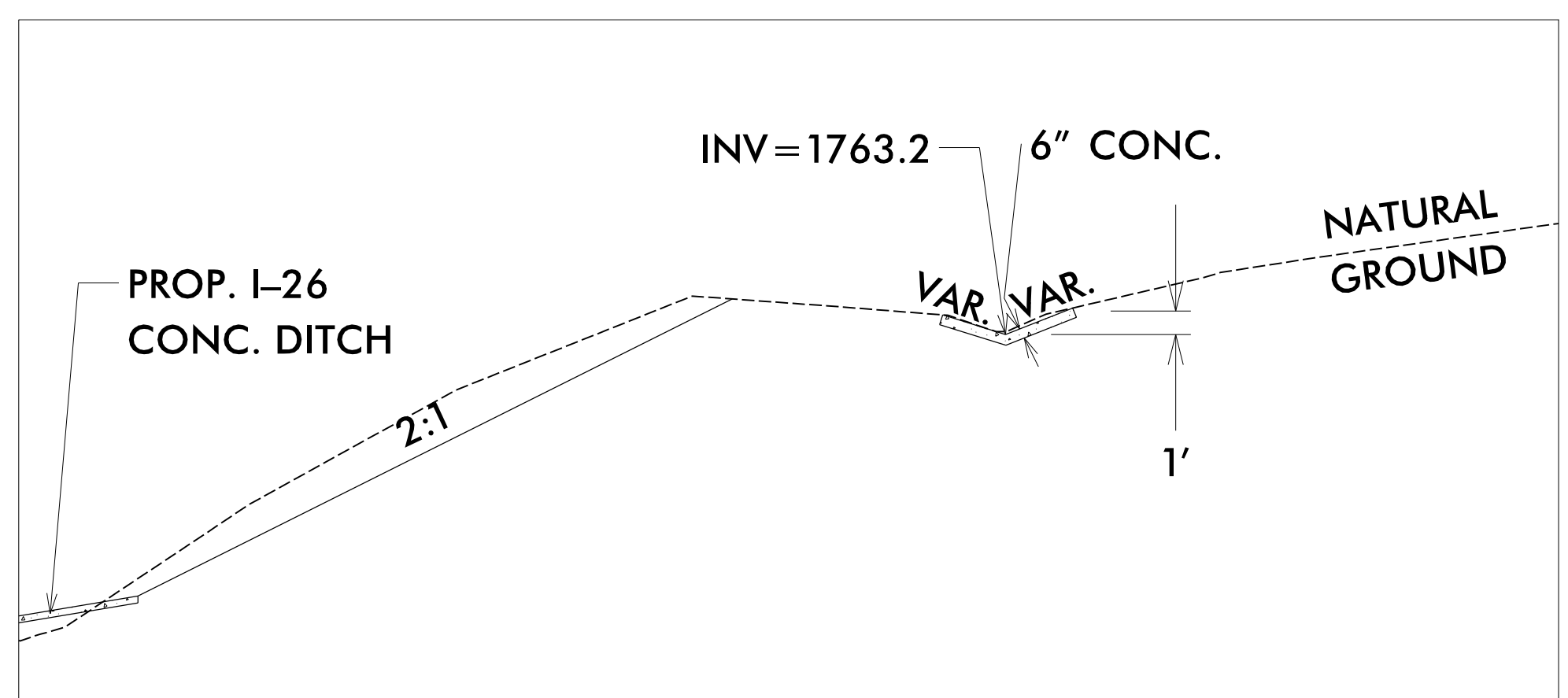

SECTION F-F

4/7/2021
X:\N6006\1-26 Howard Gap Rd Rehab\Drainage\1-26 Howards Gap_Hydr\Forebay_4_PSH.dgn
User:benegar

Hinged Grate

30" Pipe
2:1 Slope

FOREBAY #4 -126- 470+65 RT

SHEET 3 OF 3
(NOT TO SCALE)

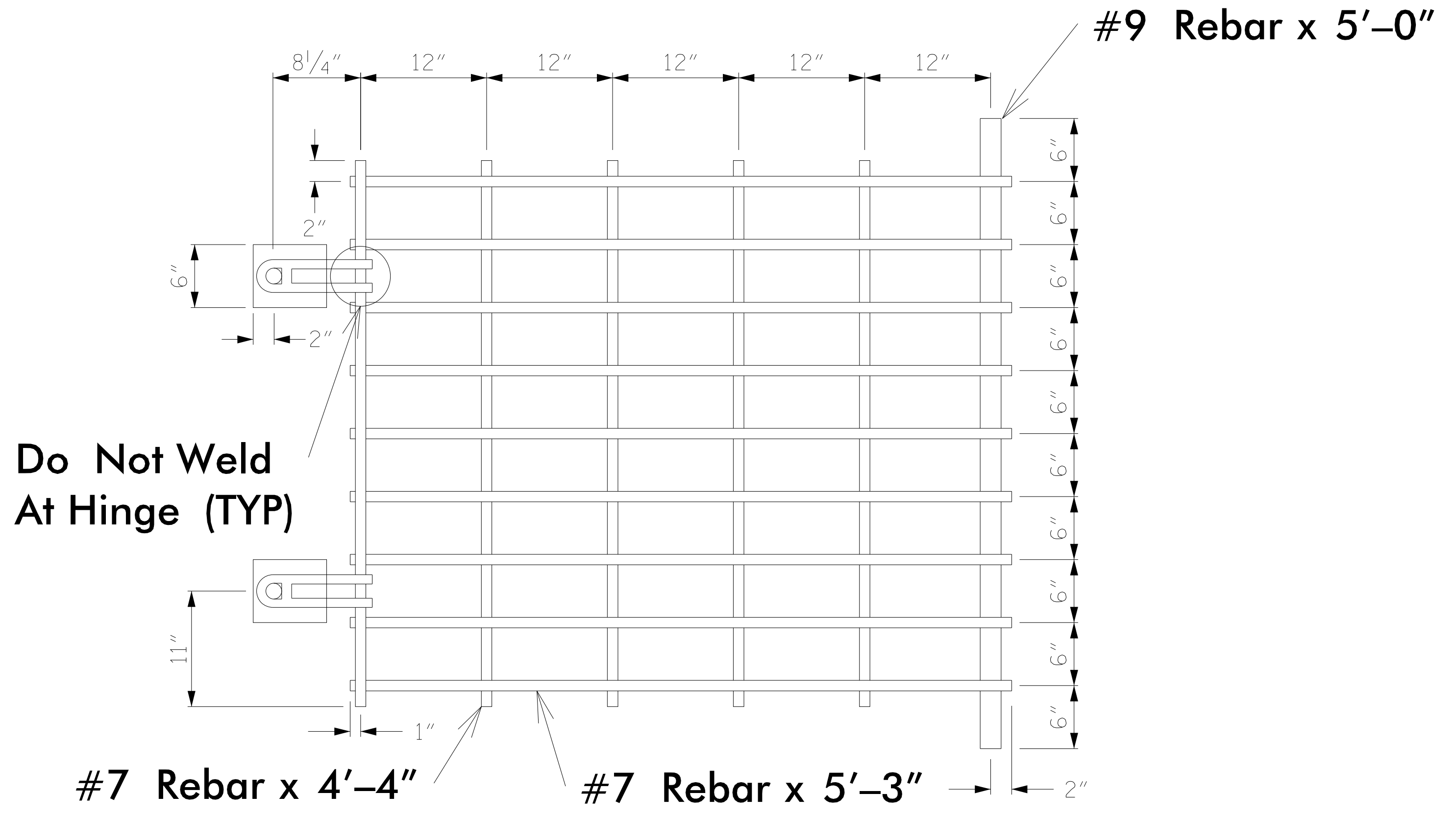
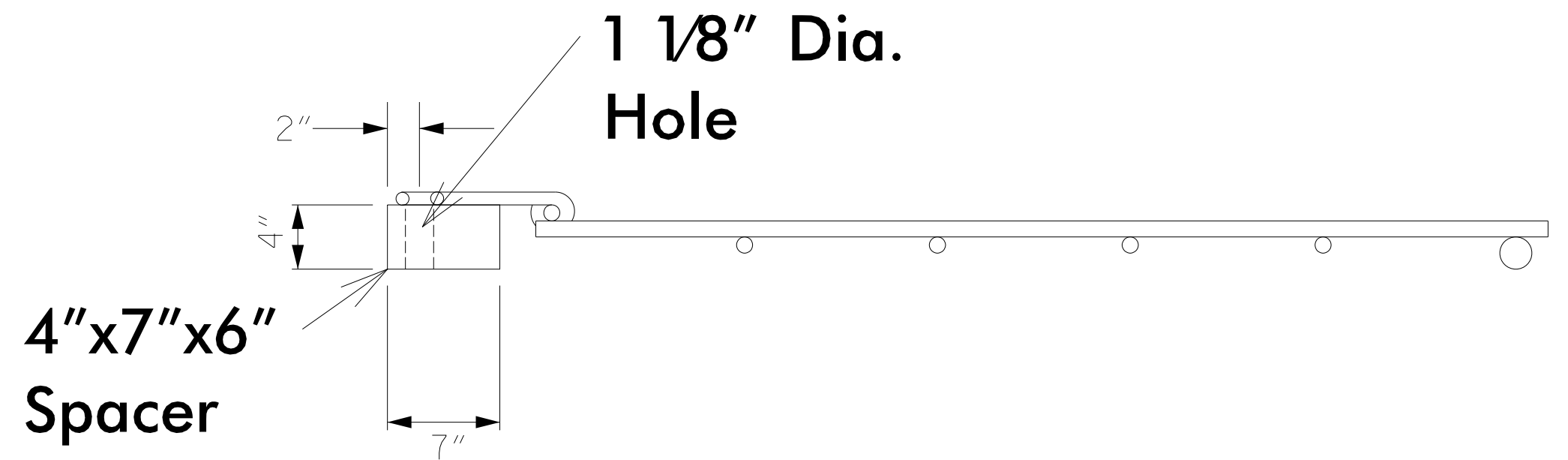
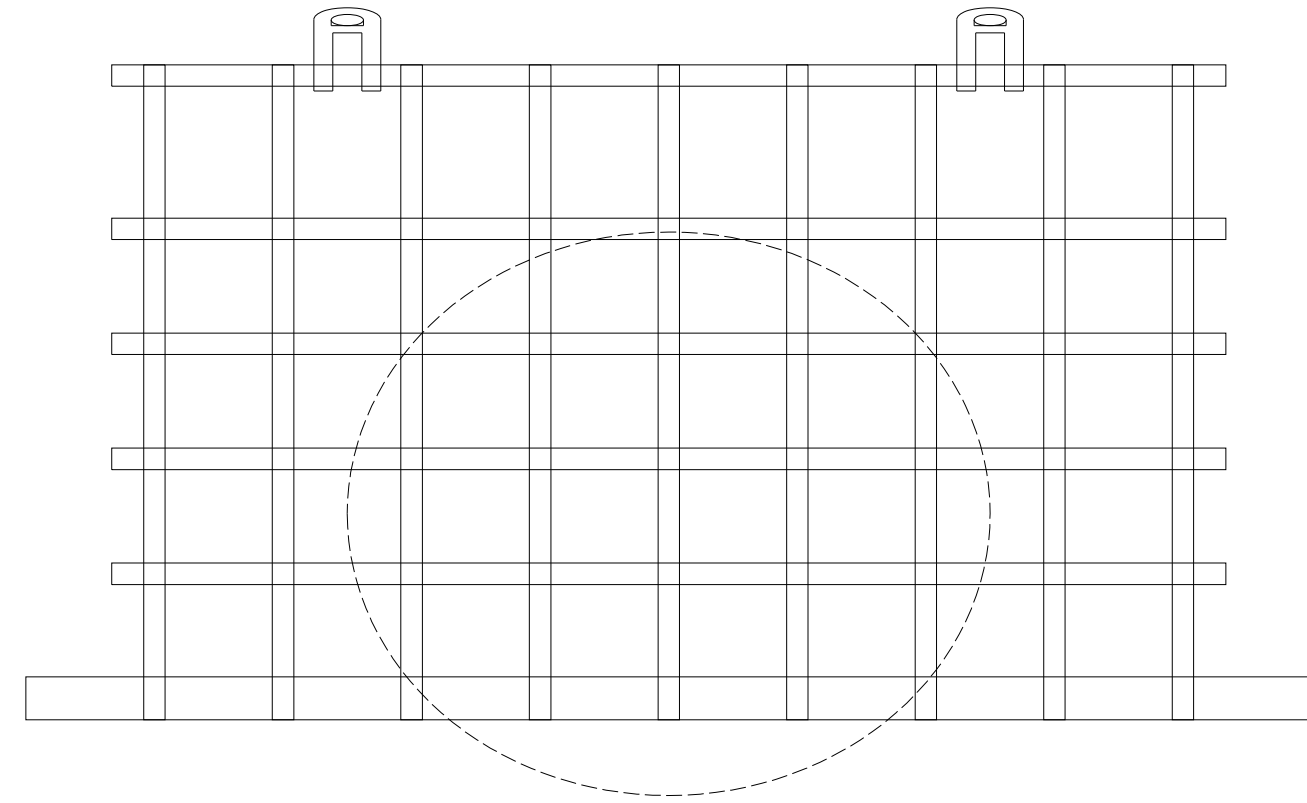
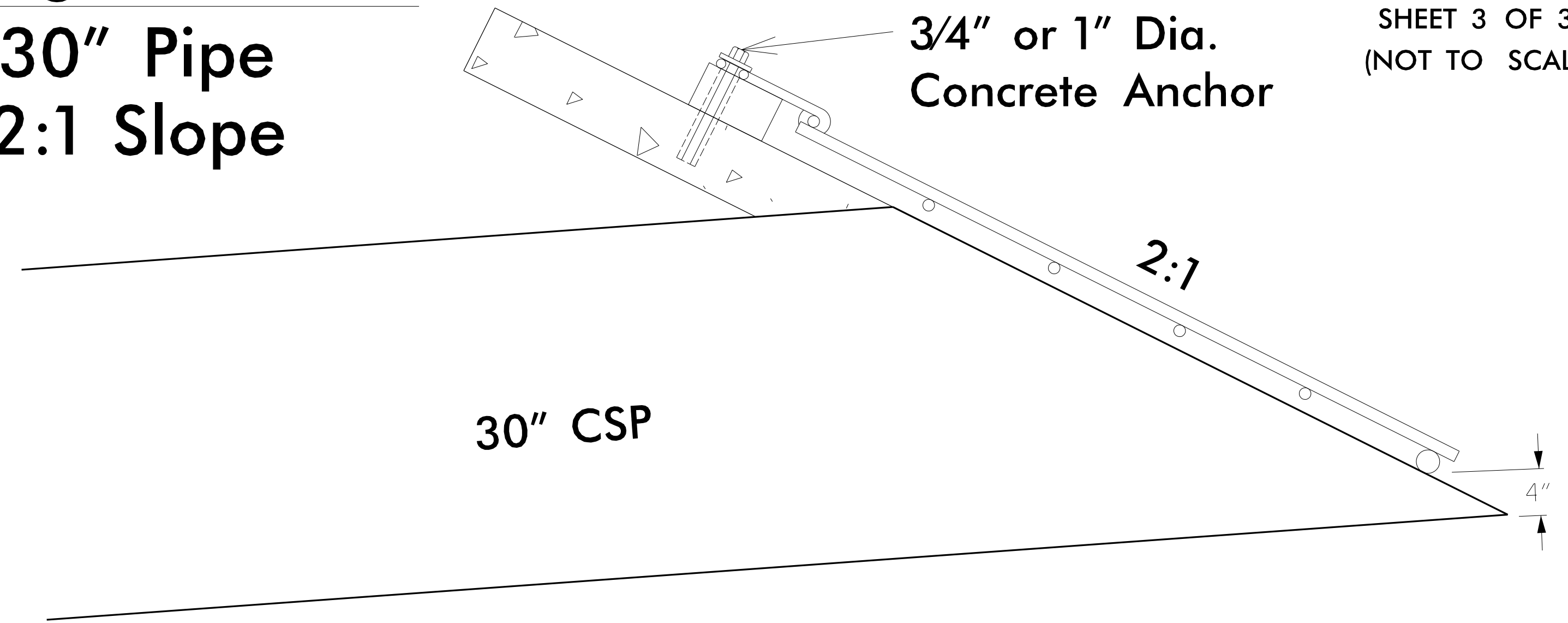

PROJECT REFERENCE NO. 15614.1075010	SHEET NO. 2D-26
R/W SHEET NO.	
HYDRAULICS ENGINEER	
DOCUMENT NOT CONSIDERED FINAL UNLESS ALL SIGNATURES COMPLETED	
TGS ENGINEERS 804-C N. LAFAYETTE ST SHELBY, NC 28150 PH (704) 476-0003 CORP. LICENSE NO.: C-0275	

HINGED GRATE NOTES:

1. ALL JOINTS, EXCEPT AS NOTED, SHALL BE FULLY WELDED AROUND JOINT WITH A MINIMUM OF A 1/4" BEAD.
2. GRATE SHALL BE REBAR AND GALVANIZED IN ACCORDANCE WITH ASTM A-153.
3. SPACER SHALL CONFORM TO AASHTO M270 GRADE 36. AFTER FABRICATION, HOT-DIP GALVANIZE SPACER IN ACCORDANCE WITH AASHTO M111.
4. USE CONCRETE ANCHORS CONSISTING OF A STUD BOLT WITH NUT AND WASHER. USE STUDS THREADED ON ONE END AND HAVING AN EXPANDED WEDGE ASSEMBLY POSITIONED AROUND A TAPERED AREA AT THE OTHER END. USE ANCHORS WHICH PROVIDE A MINIMUM SAFE HOLDING POWER OF 2875 LBS. FOR A 3/4" OR 1" DIAMETER BOLT. CALCULATE HOLDING POWER BASED ON 1/4 THE ACTUAL HOLDING POWER OF THE ANCHOR IN 3500 PSI CONCRETE AS DETERMINED BY AN APPROVED COMMERCIAL TESTING LABORATORY.
5. USE ANCHORS GALVANIZED IN ACCORDANCE WITH ASTM A-153. SIZE HOLES FOR THE CONCRETE ANCHORS IN ACCORDANCE WITH THE ANCHOR MANUFACTURER'S RECOMMENDATIONS. DRILL HOLES WITH A CARBIDE OR DIAMOND TIPPED MASONRY BIT POWERED BY A ROTARY OR ROTARY IMPACT DRILL. NO OTHER IMPACT TOOLS WILL BE PERMITTED. DRILL HOLES VERTICALLY. FURNISH DOCUMENTATION OF HOLE SIZE RECOMMENDED FOR THE SPECIFIED ANCHOR TO THE ENGINEER BEFORE DRILLING HOLES. THOROUGHLY CLEAN HOLES FOR ANCHORS OF ALL CONCRETE CHIPS, DUST, GREASE, OIL, ETC. BEFORE ANCHORS ARE INSTALLED. REPAIR ALL DAMAGE CAUSED BY THIS WORK TO THE SATISFACTION OF THE ENGINEER.
6. FOR HINGED GRATE, SEE SPECIAL PROVISIONS.

8/17/99

FOREBAY #5 -126- 481+70 RT

SHEET 1 OF 3
(NOT TO SCALE)

PROJECT REFERENCE NO. 15614.1075010	SHEET NO. 2D-27
RW SHEET NO.	
HYDRAULICS ENGINEER	
DOCUMENT NOT CONSIDERED FINAL UNLESS ALL SIGNATURES COMPLETED	
TGS ENGINEERS 804-C N. LAFAYETTE ST SHELBY, NC 28150 PH (704) 476-0003 CORP. LICENSE NO.: C-0275	

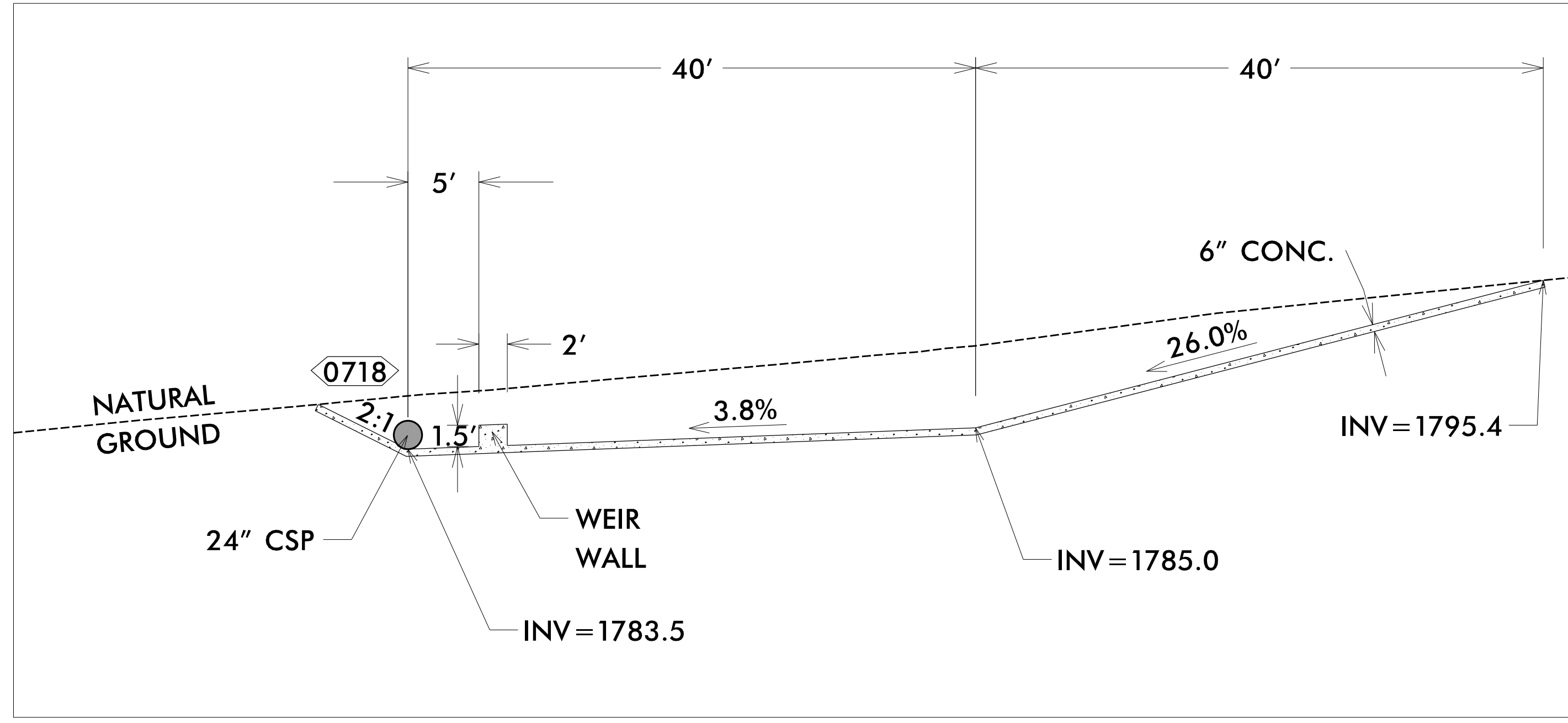

PROFILE VIEW

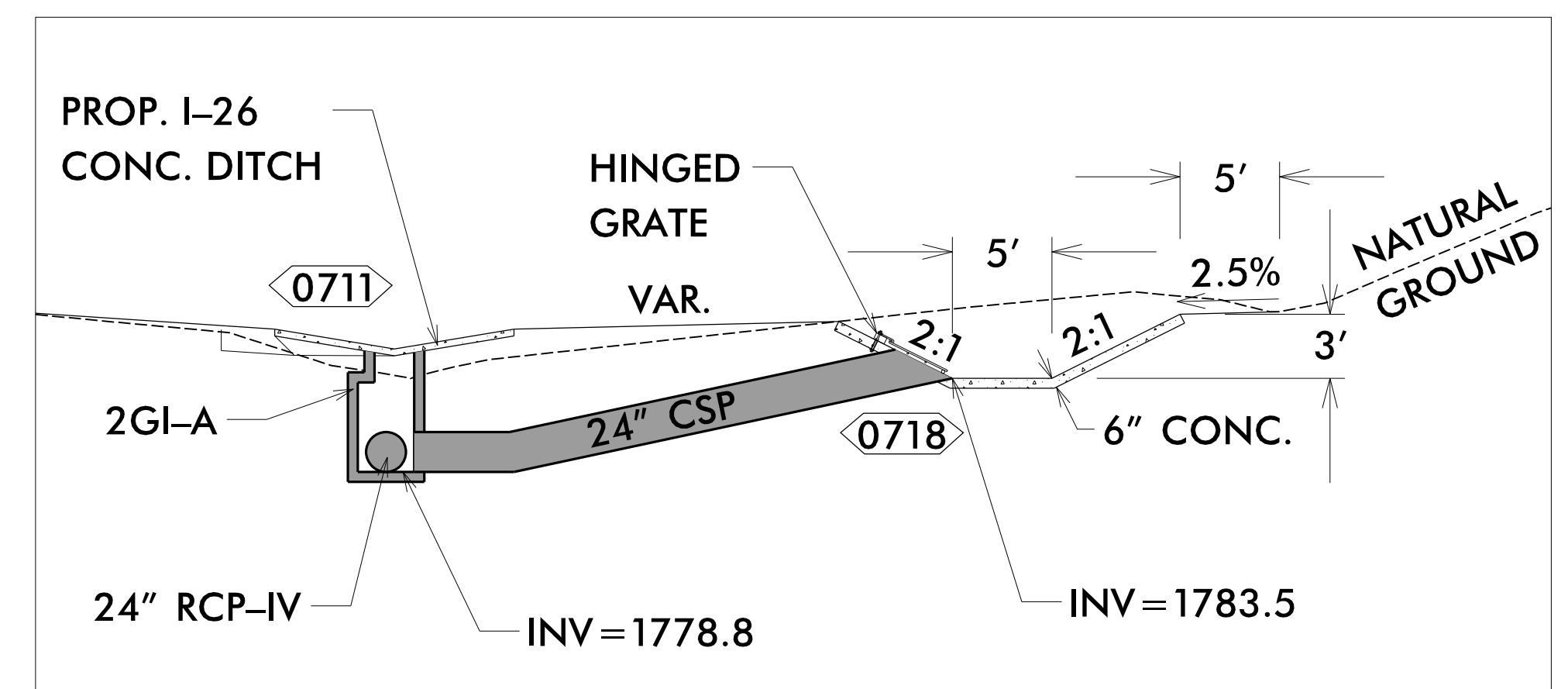

SECTION A-A

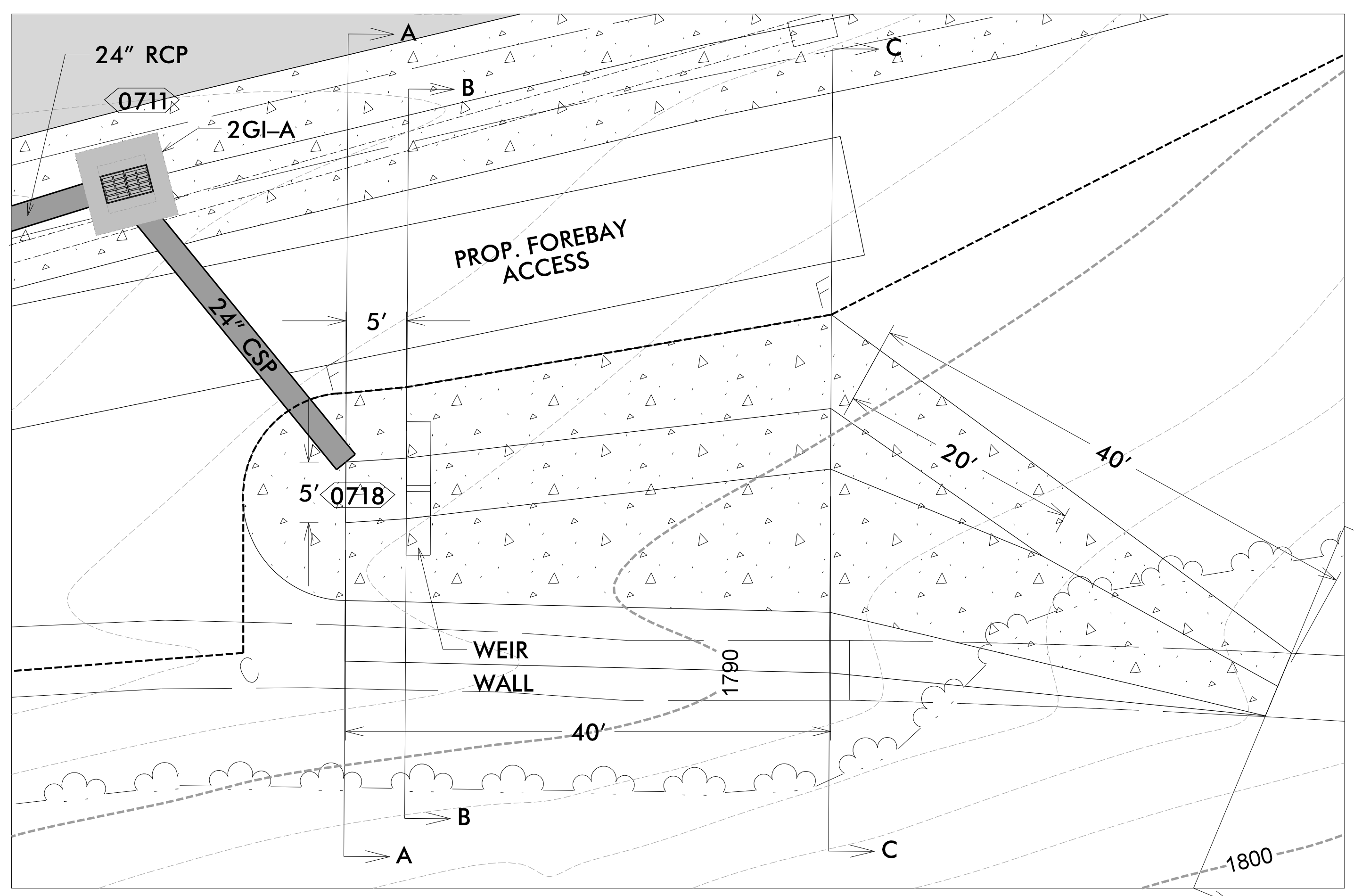

PLAN VIEW

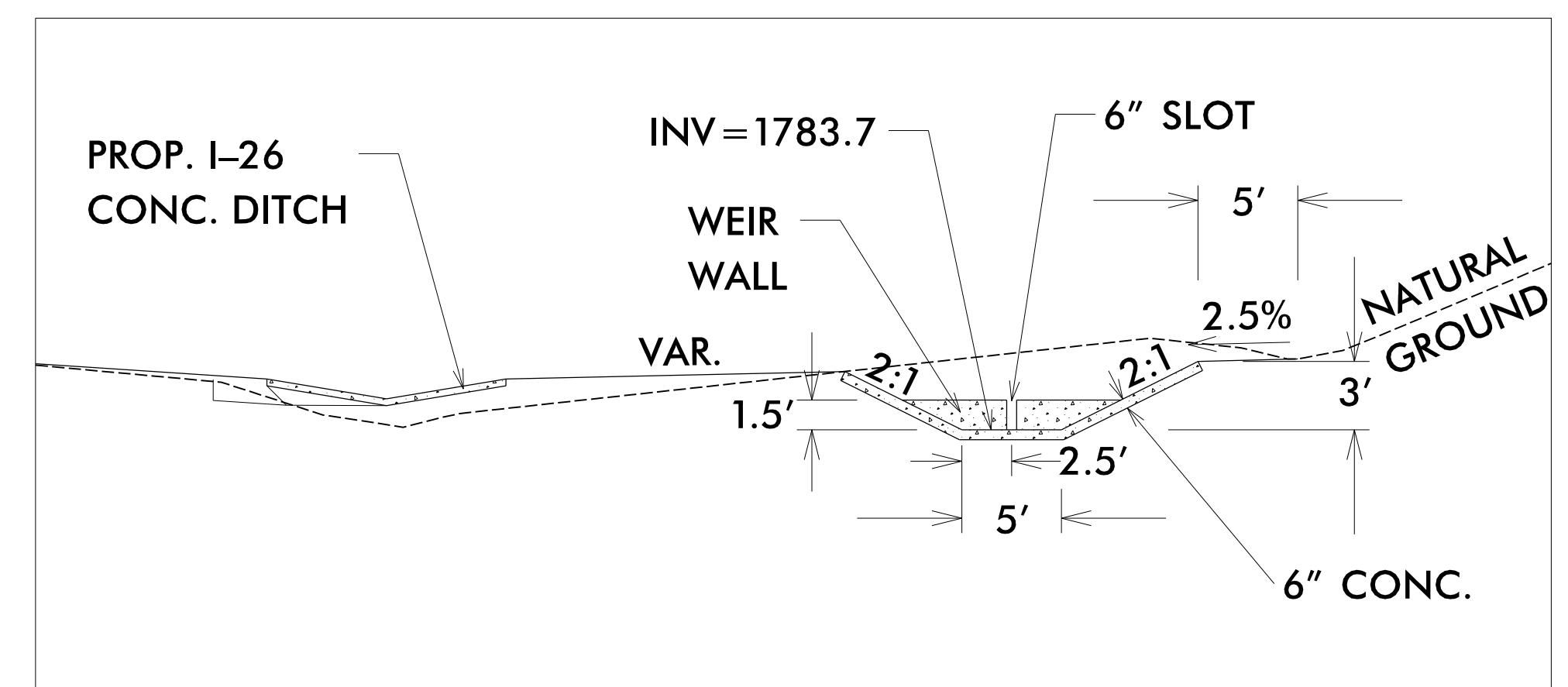

SECTION B-B

REVISIONS

4/7/2021
X:\NC\06\11-26 Howard Gap Rd Rehab\Drainage\1-26 Howards Gap_Hydr_Forebay_5_PSH.dgn
User:benegar

8/17/99

FOREBAY #5 -I26- 481+70 RT

SHEET 2 OF 3
(NOT TO SCALE)

PROJECT REFERENCE NO. 15614.1075010	SHEET NO. 2D-28
RW SHEET NO.	
HYDRAULICS ENGINEER	
DOCUMENT NOT CONSIDERED FINAL UNLESS ALL SIGNATURES COMPLETED	
	TGS ENGINEERS 804-C N. LAFAYETTE ST SHELBY, NC 28150 PH (704) 476-0003 CORP. LICENSE NO.: C-0275

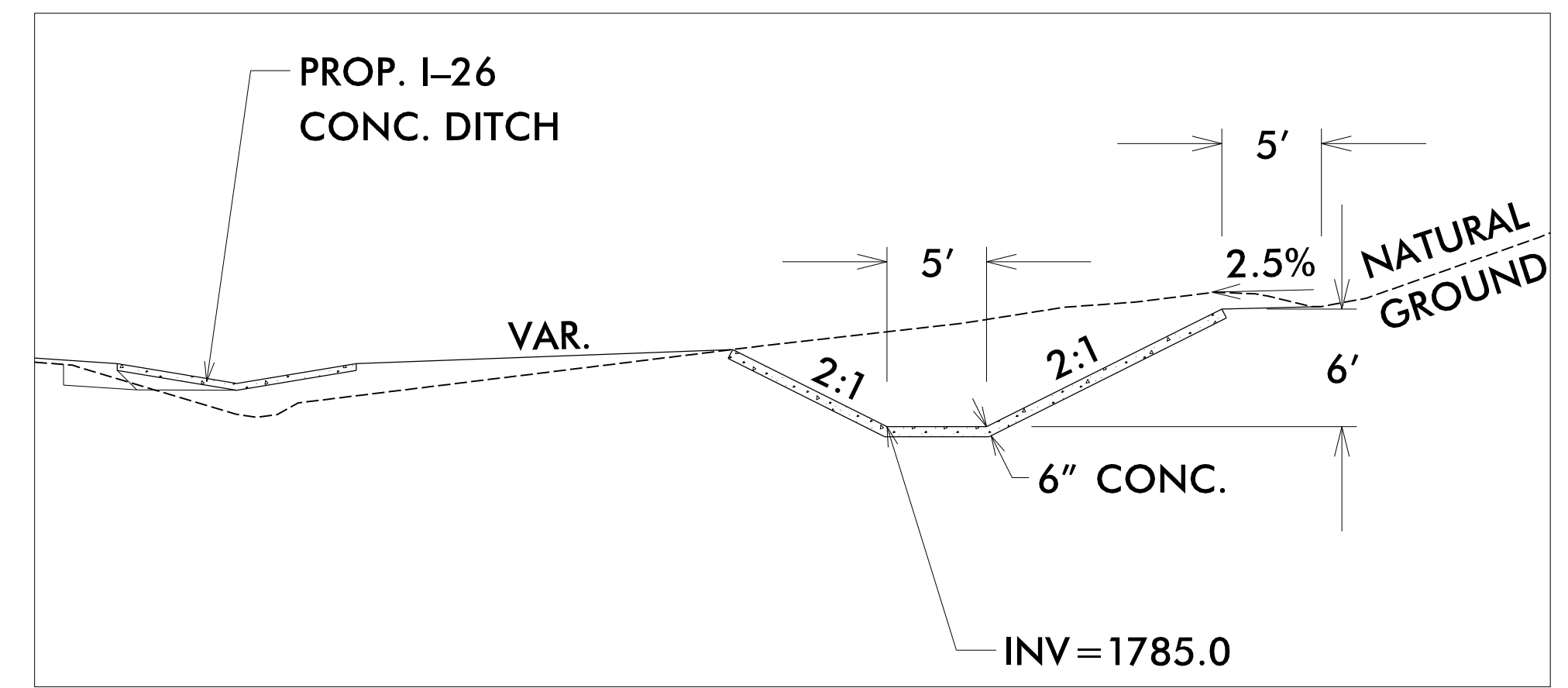

SECTION C-C

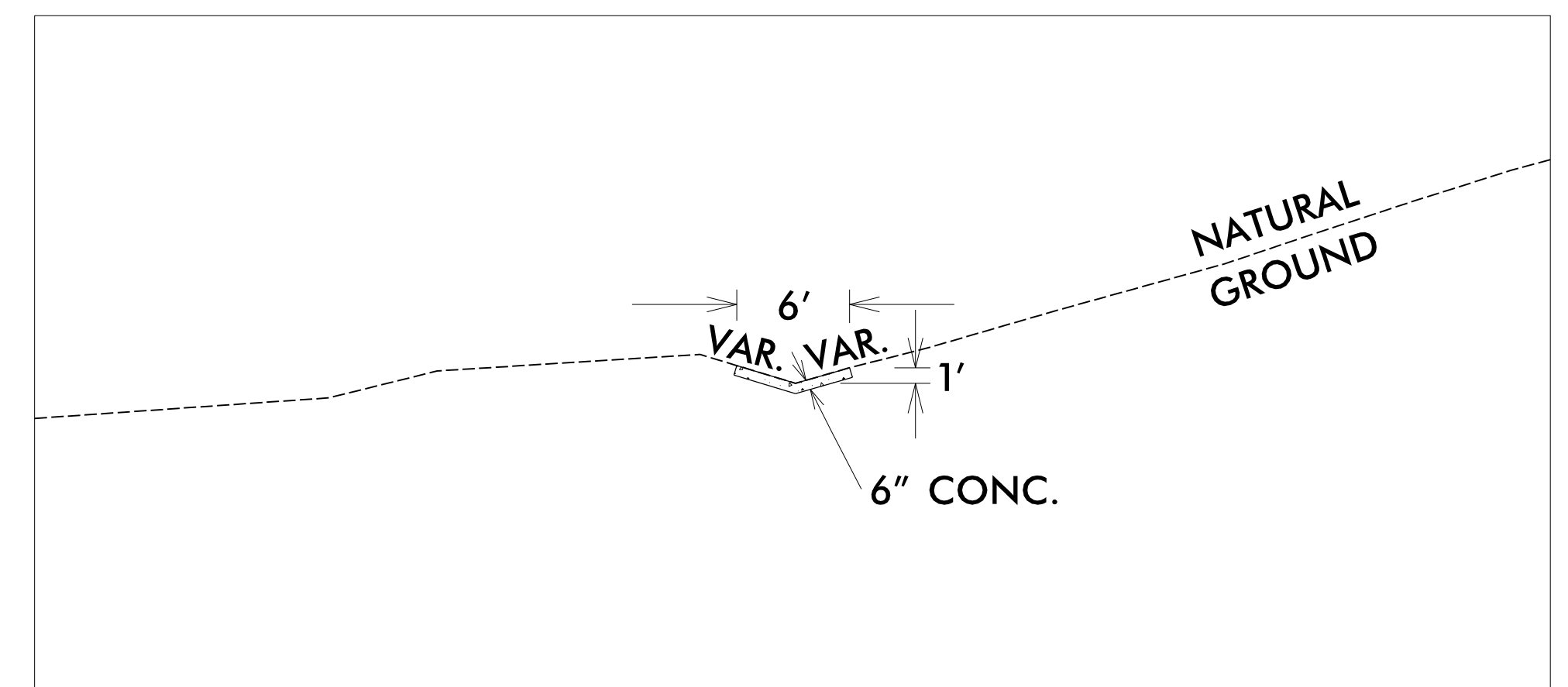

SECTION D-D

4/7/2021
X:\N6007\I-26 Howard Gap Rd Rehab\Drainage\I-26 Howards Gap_Hydr_Forebay_5_PSH.dgn
User: bhenegar

8/17/99

FOREBAY #5 -126- 481+70 RT

SHEET 3 OF 3
(NOT TO SCALE)

Hinged Grate

24" Pipe 2:1 Slope

PROJECT REFERENCE NO. 15614.1075010	SHEET NO. 2D-29
R/W SHEET NO.	
HYDRAULICS ENGINEER	
DOCUMENT NOT CONSIDERED FINAL UNLESS ALL SIGNATURES COMPLETED	
TGS ENGINEERS 804-C N. LAFAYETTE ST SHELBY, NC 28150 PH (704) 476-0003 CORP. LICENSE NO.: C-0275	

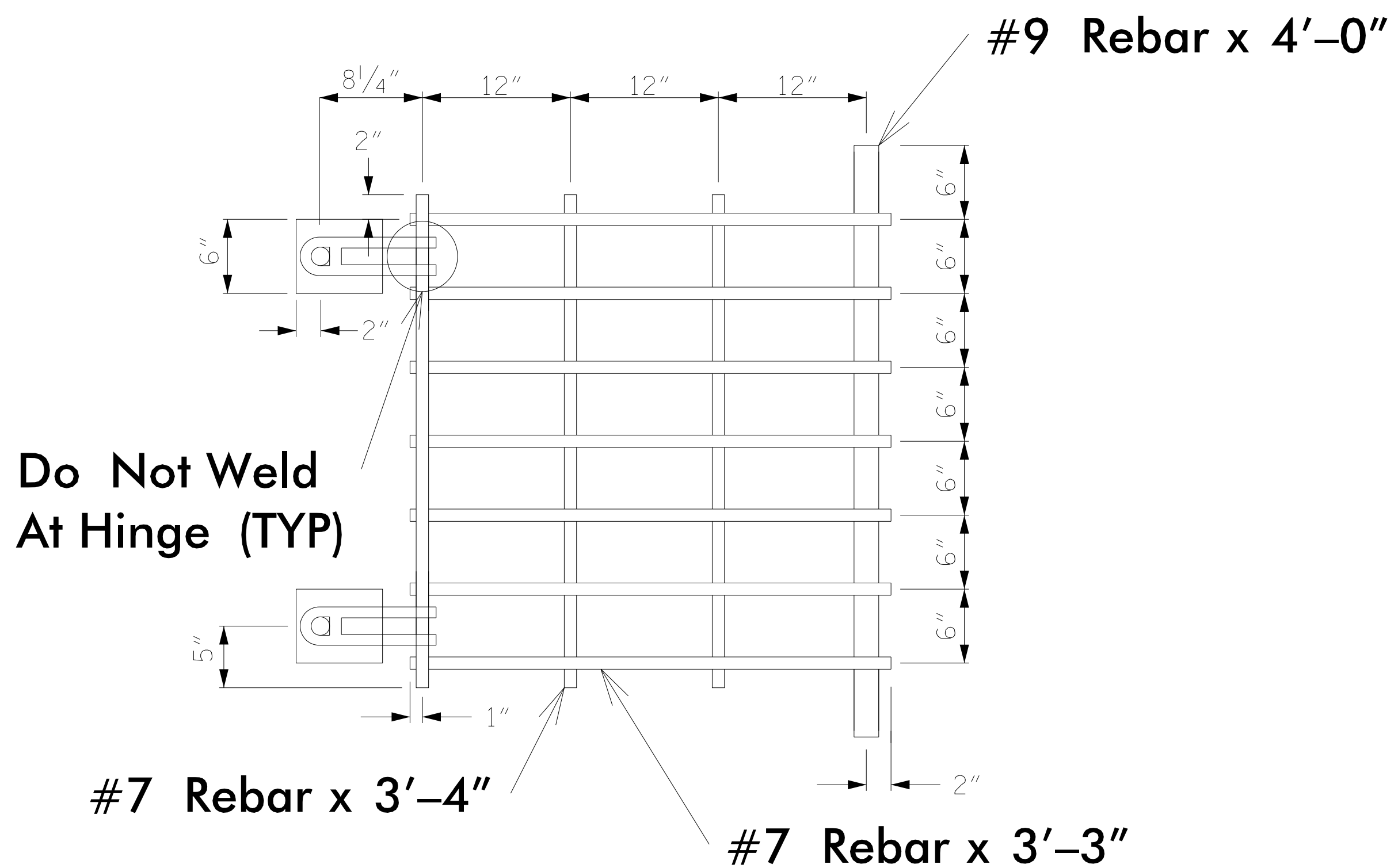
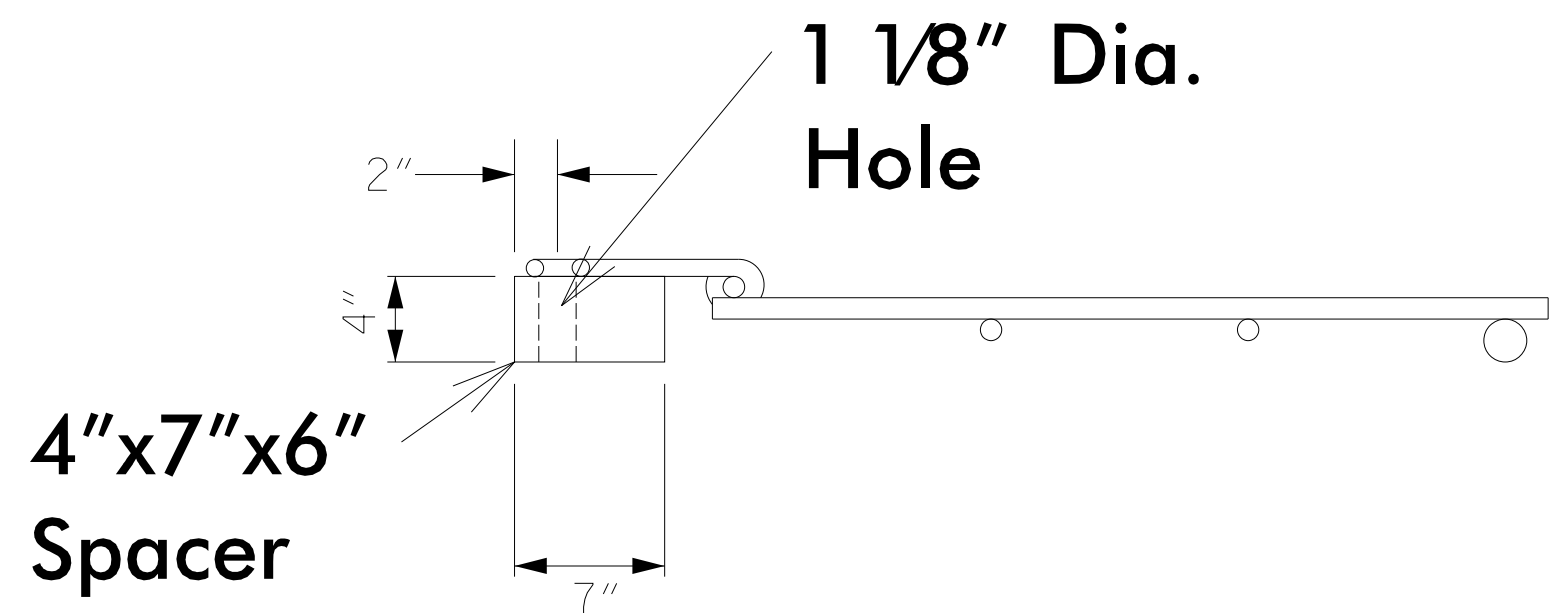
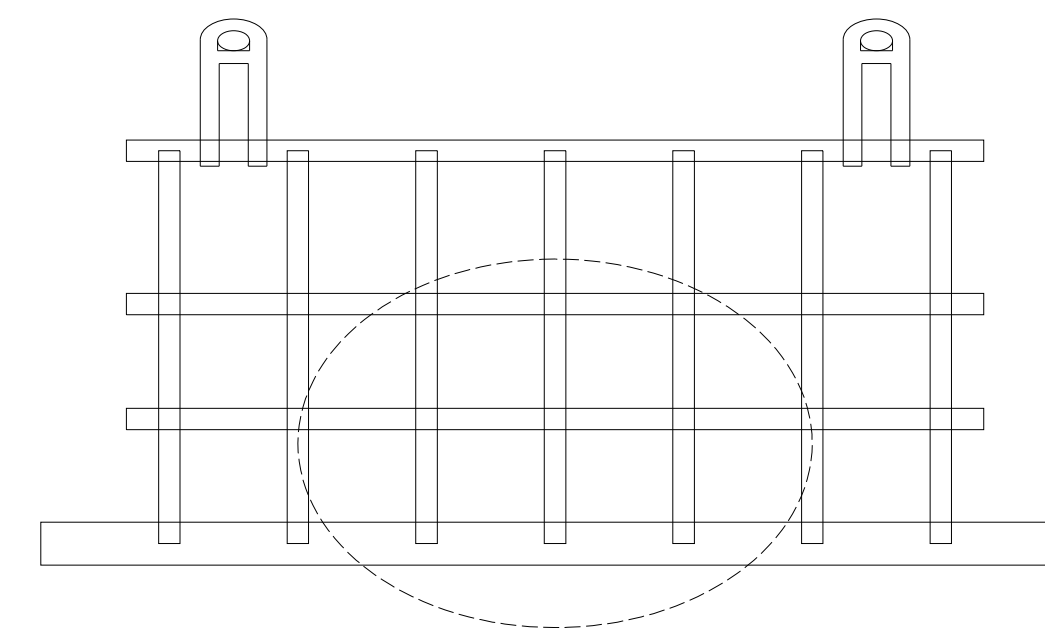
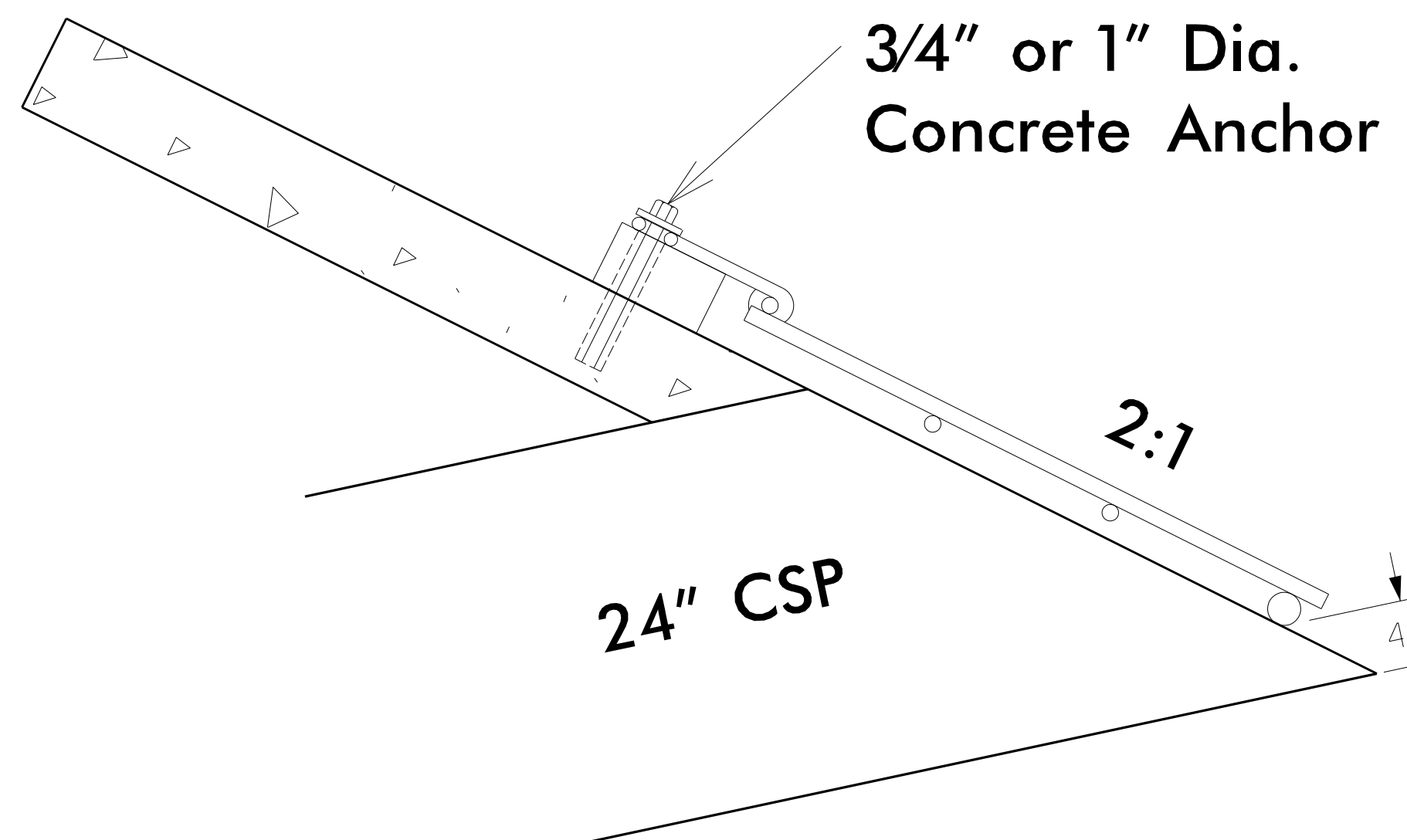

HINGED GRATE NOTES:

- ALL JOINTS, EXCEPT AS NOTED, SHALL BE FULLY WELDED AROUND JOINT WITH A MINIMUM OF A 1/4" BEAD.
- GRATE SHALL BE REBAR AND GALVANIZED IN ACCORDANCE WITH ASTM A-153.
- SPACER SHALL CONFORM TO AASHTO M270 GRADE 36. AFTER FABRICATION, HOT-DIP GALVANIZE SPACER IN ACCORDANCE WITH AASHTO M111.
- USE CONCRETE ANCHORS CONSISTING OF A STUD BOLT WITH NUT AND WASHER. USE STUDS THREADED ON ONE END AND HAVING AN EXPANDED WEDGE ASSEMBLY POSITIONED AROUND A TAPERED AREA AT THE OTHER END. USE ANCHORS WHICH PROVIDE A MINIMUM SAFE HOLDING POWER OF 2875 LBS. FOR A 3/4" OR 1" DIAMETER BOLT. CALCULATE HOLDING POWER BASED ON 1/4 THE ACTUAL HOLDING POWER OF THE ANCHOR IN 3500 PSI CONCRETE AS DETERMINED BY AN APPROVED COMMERCIAL TESTING LABORATORY.
- USE ANCHORS GALVANIZED IN ACCORDANCE WITH ASTM A-153. SIZE HOLES FOR THE CONCRETE ANCHORS IN ACCORDANCE WITH THE ANCHOR MANUFACTURER'S RECOMMENDATIONS. DRILL HOLES WITH A CARBIDE OR DIAMOND TIPPED MASONRY BIT POWERED BY A ROTARY OR ROTARY IMPACT DRILL. NO OTHER IMPACT TOOLS WILL BE PERMITTED. DRILL HOLES VERTICALLY. FURNISH DOCUMENTATION OF HOLE SIZE RECOMMENDED FOR THE SPECIFIED ANCHOR TO THE ENGINEER BEFORE DRILLING HOLES. THOROUGHLY CLEAN HOLES FOR ANCHORS OF ALL CONCRETE CHIPS, DUST, GREASE, OIL, ETC. BEFORE ANCHORS ARE INSTALLED. REPAIR ALL DAMAGE CAUSED BY THIS WORK TO THE SATISFACTION OF THE ENGINEER.
- FOR HINGED GRATE, SEE SPECIAL PROVISIONS.

4/7/2021
X:\NG\007\1-26 Howard Gap Rd Rehab\Drainage\1-26 Howard Gap_Hydr\Forebay_5_PSH.dgn
jseribbenegar

5/14/99

PIPE PROFILE - 0409 TO 0401

SCALE
1" = 30' HORIZONTAL
1" = 30' VERTICAL

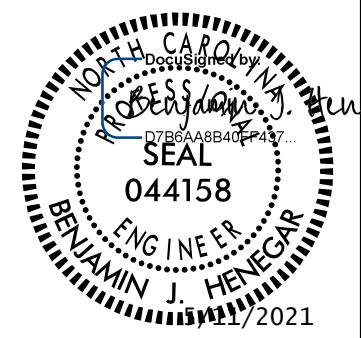
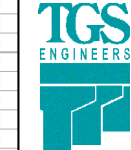
PROJECT REFERENCE NO. 15614.1075010	SHEET NO. 2D-30
HYDRAULICS ENGINEER	
	
DOCUMENT NOT CONSIDERED FINAL UNLESS ALL SIGNATURES COMPLETED	
 TGS ENGINEERS 804-C N. LAFAYETTE ST SHELBY, NC 28150 PH (704) 476-0003 CORP. LICENSE NO.: C-0275	

4/7/2021 11:26 Howard Gap Rd Rehab\Drainage\I-26 Howards Gap_Hyd.PFL Layout_0409_PSH.dgn User:benhenschel

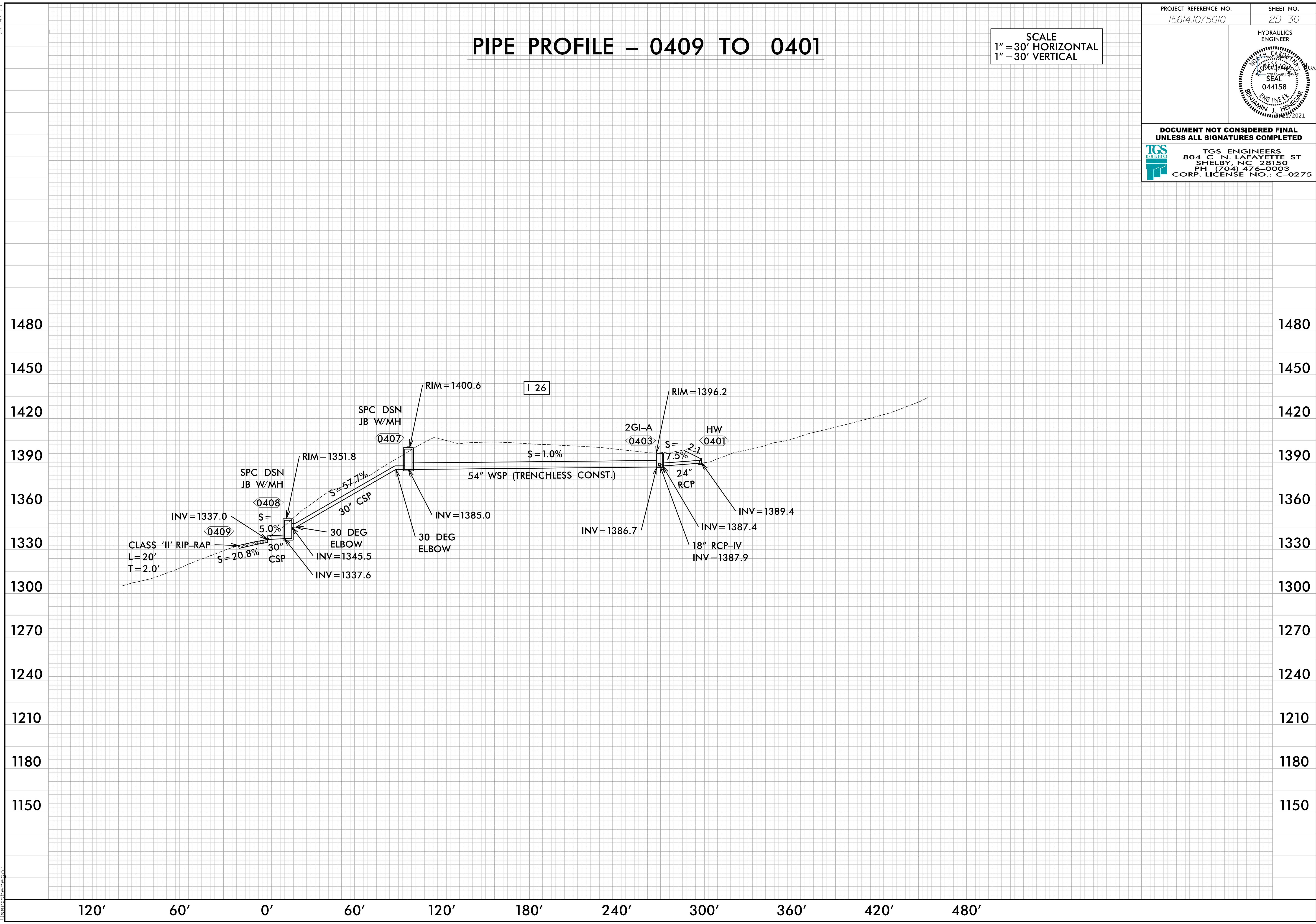

5/14/99

PIPE PROFILE - 0539 TO 0522

SCALE
1" = 30' HORIZONTAL
1" = 30' VERTICAL

PROJECT REFERENCE NO. 15614.1075010	SHEET NO. 2D-31
HYDRAULICS ENGINEER	
DOCUMENT NOT CONSIDERED FINAL UNLESS ALL SIGNATURES COMPLETED	
TGS ENGINEERS 804-C N. LAFAYETTE ST SHELBY, NC 28150 PH (704) 476-0003 CORP. LICENSE NO.: C-0275	

4/7/2021 11:26 Howard Gap Rd Rehab\Drainage\I-26 Howards Gap_Hyd.PFL Layout_0539_PSH01.dgn
User: bhanagar

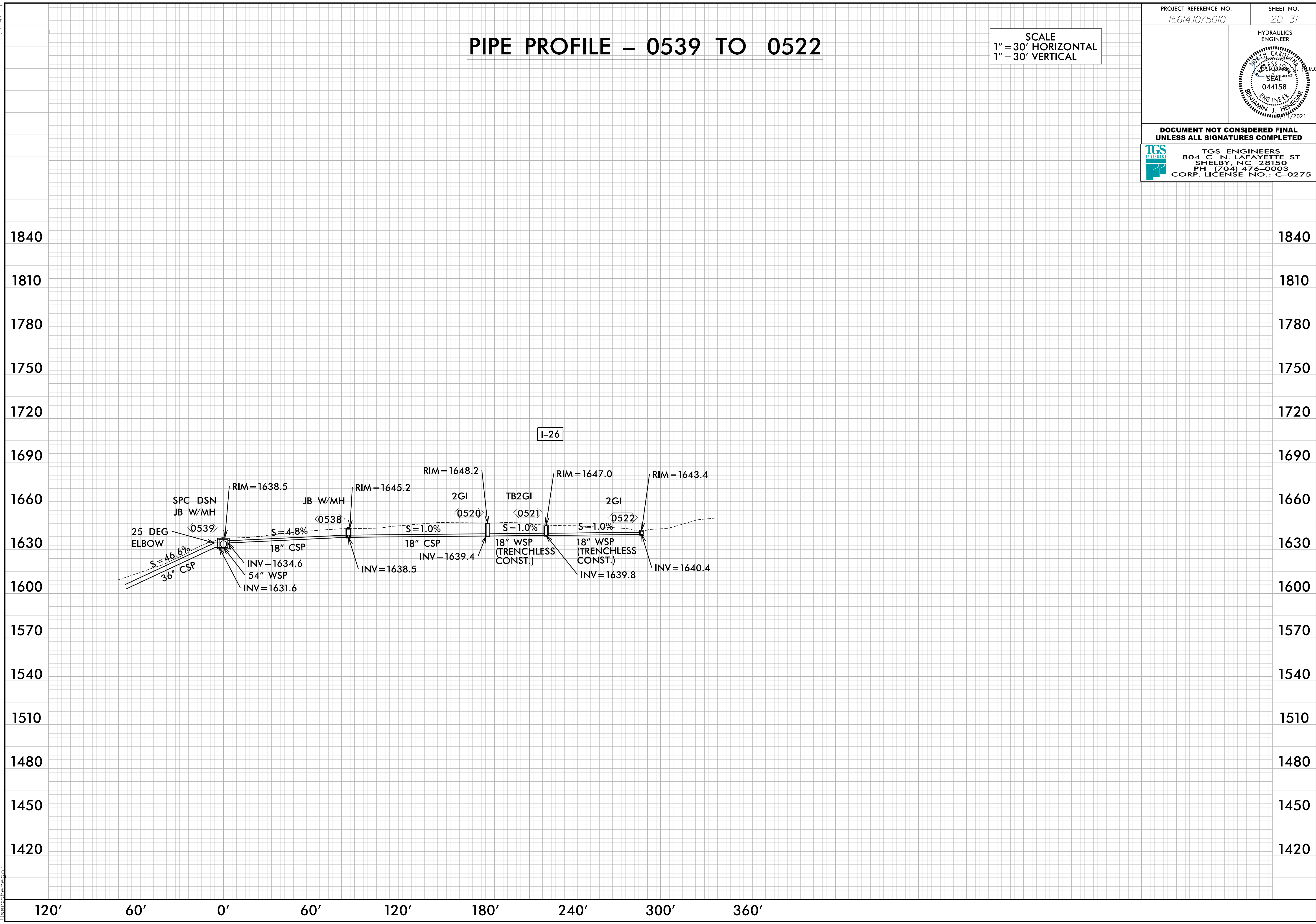

5/14/99

PIPE PROFILE - 0504 TO 0506

SCALE
1" = 30' HORIZONTAL
1" = 30' VERTICAL

PROJECT REFERENCE NO. 15614.1075010	SHEET NO. 2D-32
HYDRAULICS ENGINEER	
DOCUMENT NOT CONSIDERED FINAL UNLESS ALL SIGNATURES COMPLETED	
TGS ENGINEERS 804-C N. LAFAYETTE ST SHELBY, NC 28150 PH (704) 476-0003 CORP. LICENSE NO.: C-0275	

X:\15614\1-26 Howard Gap Rd Rehab\Drainage\1-26 Howards Gap_Hyd.PFL_Layout_0504_PSH01.dgn
User: bjenhsc

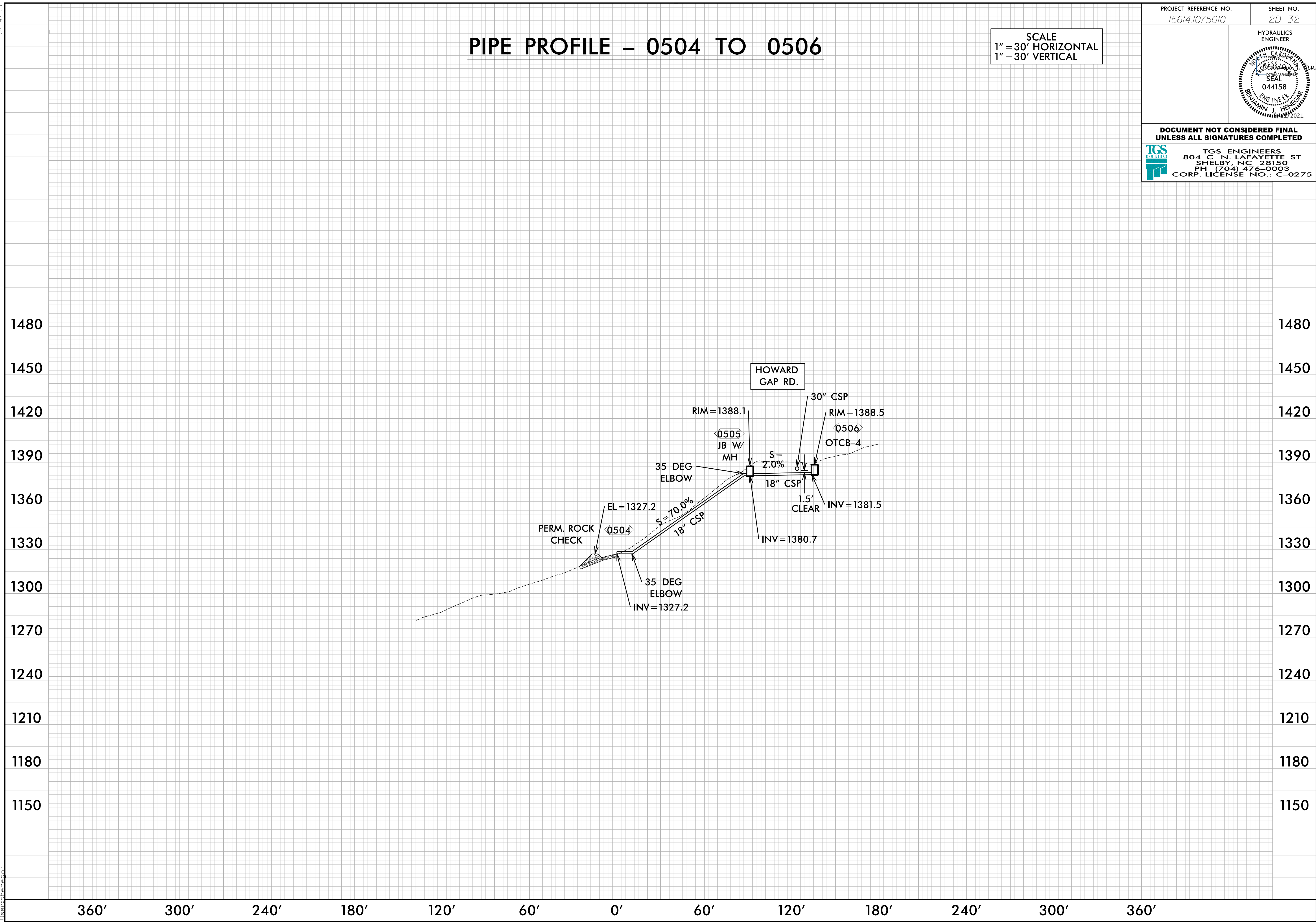

1480
1450
1420
1390
1360
1330
1300
1270
1240
1210
1180
1150

1480
1450
1420
1390
1360
1330
1300
1270
1240
1210
1180
1150

360' 300' 240' 180' 120' 60' 0' 60' 120' 180' 240' 300' 360'

5/14/99

PIPE PROFILE - 0901 TO 0525

SHEET 1 OF 2

SCALE
1" = 30' HORIZONTAL
1" = 30' VERTICAL

PROJECT REFERENCE NO. 15614.1075010	SHEET NO. 2D-33
HYDRAULICS ENGINEER	
DOCUMENT NOT CONSIDERED FINAL UNLESS ALL SIGNATURES COMPLETED	
TGS ENGINEERS 804-C N. LAFAYETTE ST SHELBY, NC 28150 PH (704) 476-0003 CORP. LICENSE NO.: C-0275	

10/7/2021
K:\Projects\1-26 Howard Gap Rd Rehab\Drainage\1-26 Howard Gap_Hyd.PFL_Layout_0901_PSH01.dgn
User: jhenschel

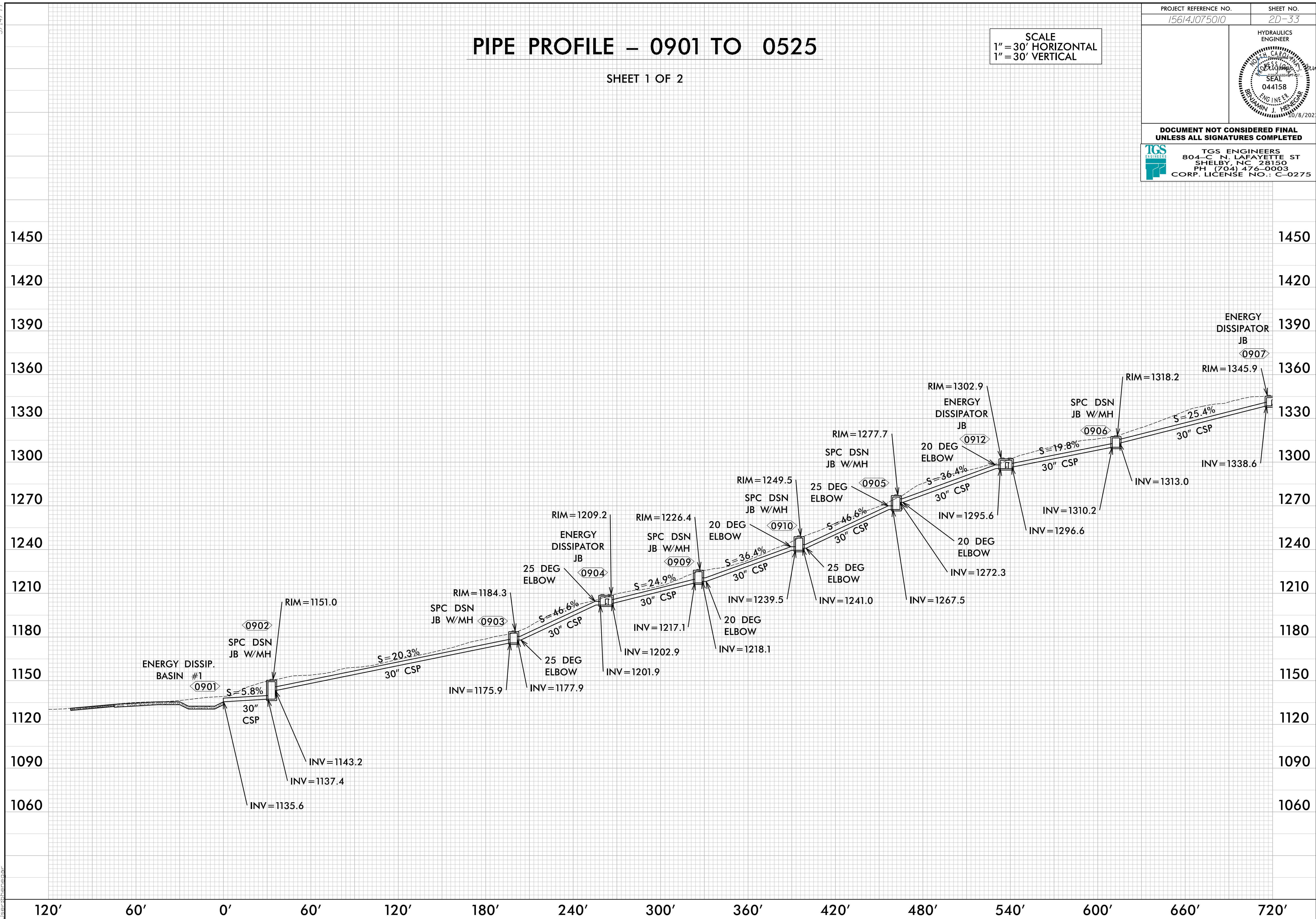

5/14/99

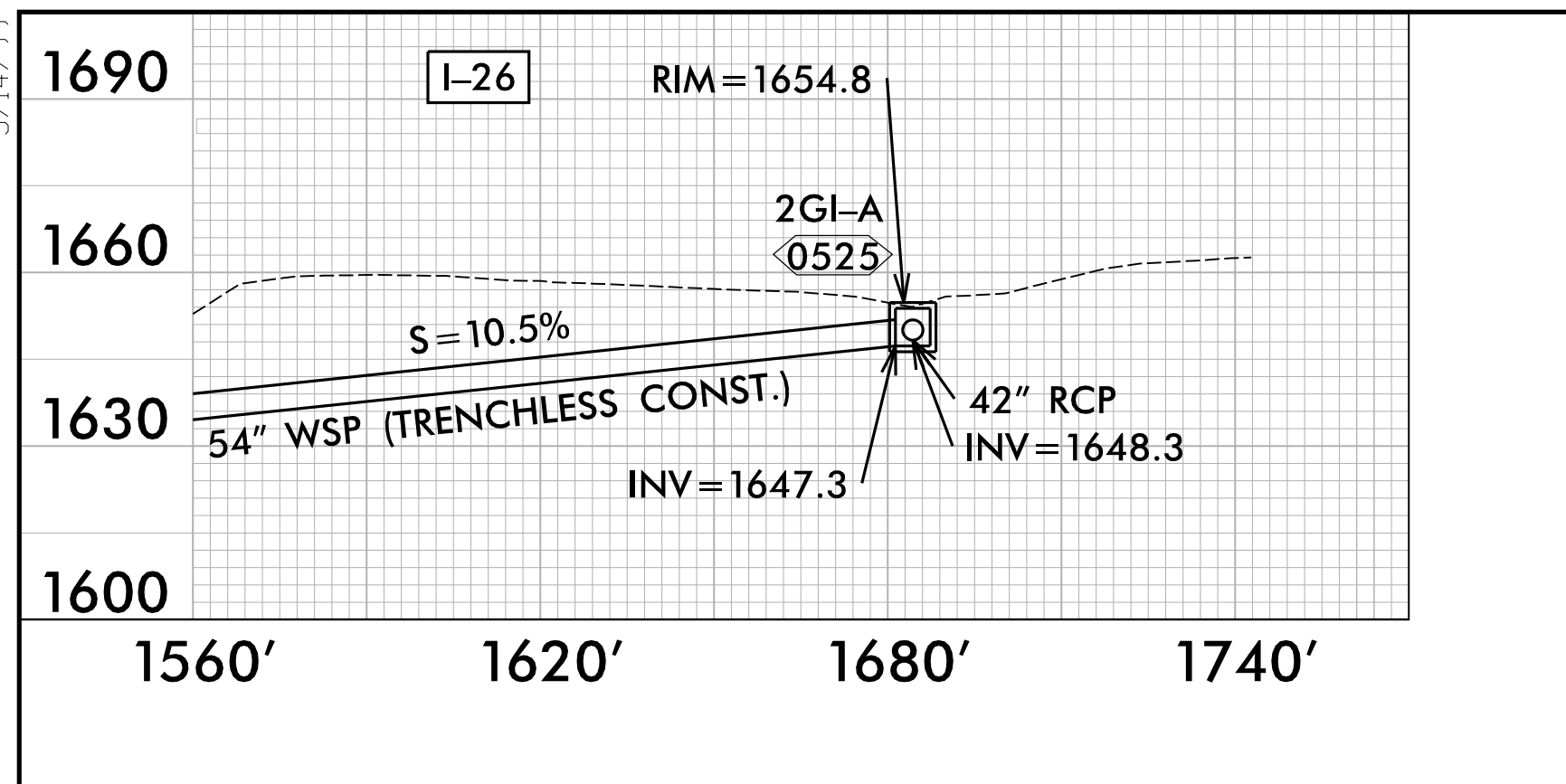

PIPE PROFILE - 0901 TO 0525

SHEET 2 OF 2

SCALE
 1" = 30' HORIZONTAL
 1" = 30' VERTICAL

PROJECT REFERENCE NO. 15614.1075010	SHEET NO. 20-34
HYDRAULICS ENGINEER	
DOCUMENT NOT CONSIDERED FINAL UNLESS ALL SIGNATURES COMPLETED	
 TGS ENGINEERS 804-C N. LAFAYETTE ST SHELBY, NC 28150 PH (704) 476-0003 CORP. LICENSE NO.: C-0275	

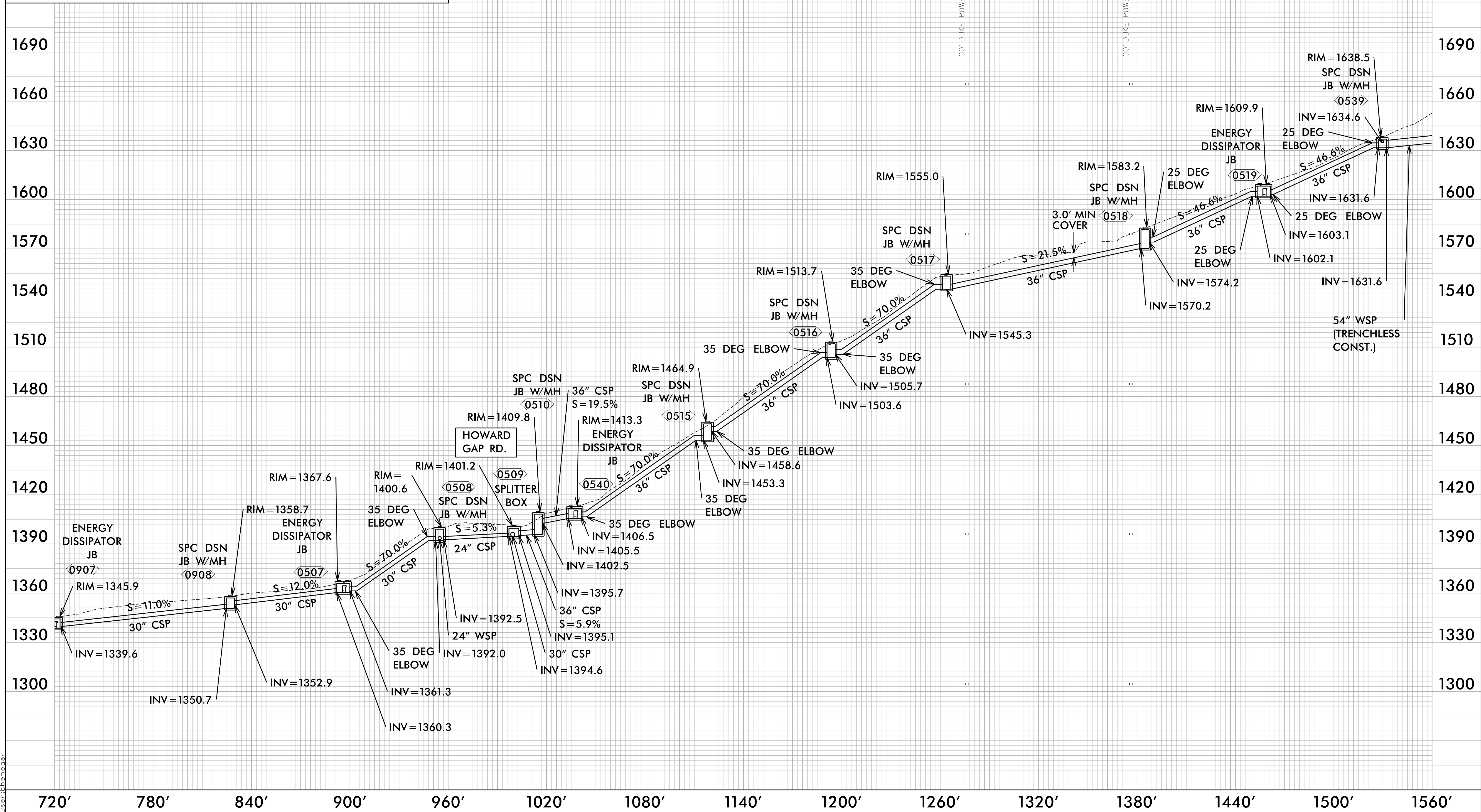

4/15/2021
 X:\Projects\1-26 Howard Gap Rd Rehab\Drainage\1-26 Howards Gap_Hyd.PFL_Layout_0901_PSH02.dgn
 User: bhench

5/14/99

PIPE PROFILE - 0542 TO 0607

SCALE
1" = 30' HORIZONTAL
1" = 30' VERTICAL

PROJECT REFERENCE NO. 15614.1075010	SHEET NO. 2D-35
HYDRAULICS ENGINEER	

**DOCUMENT NOT CONSIDERED FINAL
UNLESS ALL SIGNATURES COMPLETED**

TGS ENGINEERS
804-C N. LAFAYETTE ST
SHELBY, NC 28150
PH (704) 476-0003
CORP. LICENSE NO.: C-0275

I:\7/2021\K\1-26 Howard Gap Rd Rehab\Drainage\1-26 Howards Gap_Hyd.PFL_Layout_0542_PSH01.dgn
User: jhanner

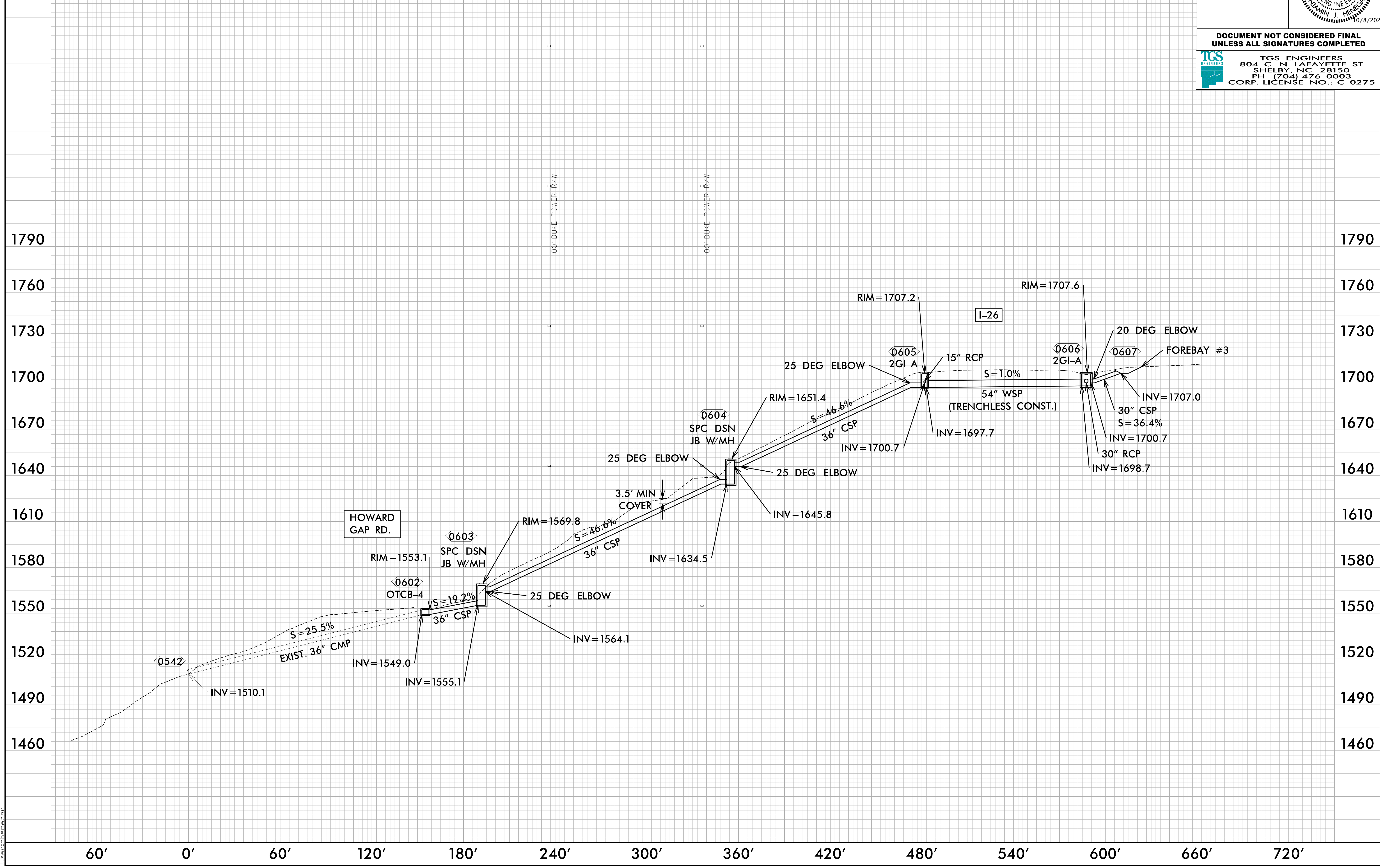

1790
1760
1730
1700
1670
1640
1610
1580
1550
1520
1490
1460

1790
1760
1730
1700
1670
1640
1610
1580
1550
1520
1490
1460

60' 0' 60' 120' 180' 240' 300' 360' 420' 480' 540' 600' 660' 720'

5/14/99

PIPE PROFILE – 0614 TO 0622

SCALE
1" = 30' HORIZONTAL
1" = 30' VERTICAL

PROJECT REFERENCE NO. 15614.1075010	SHEET NO. 2D-36
HYDRAULICS ENGINEER	
DOCUMENT NOT CONSIDERED FINAL UNLESS ALL SIGNATURES COMPLETED	
TGS ENGINEERS 804-C N. LAFAYETTE ST SHELBY, NC 28150 PH (704) 476-0003 CORP. LICENSE NO.: C-0275	

4/7/2021 11:26 Howard Gap Rd Rehab\Drainage\I-26 Howards Gap_Hyd_PFL_Layout_0614_PSH01.dgn User:shane

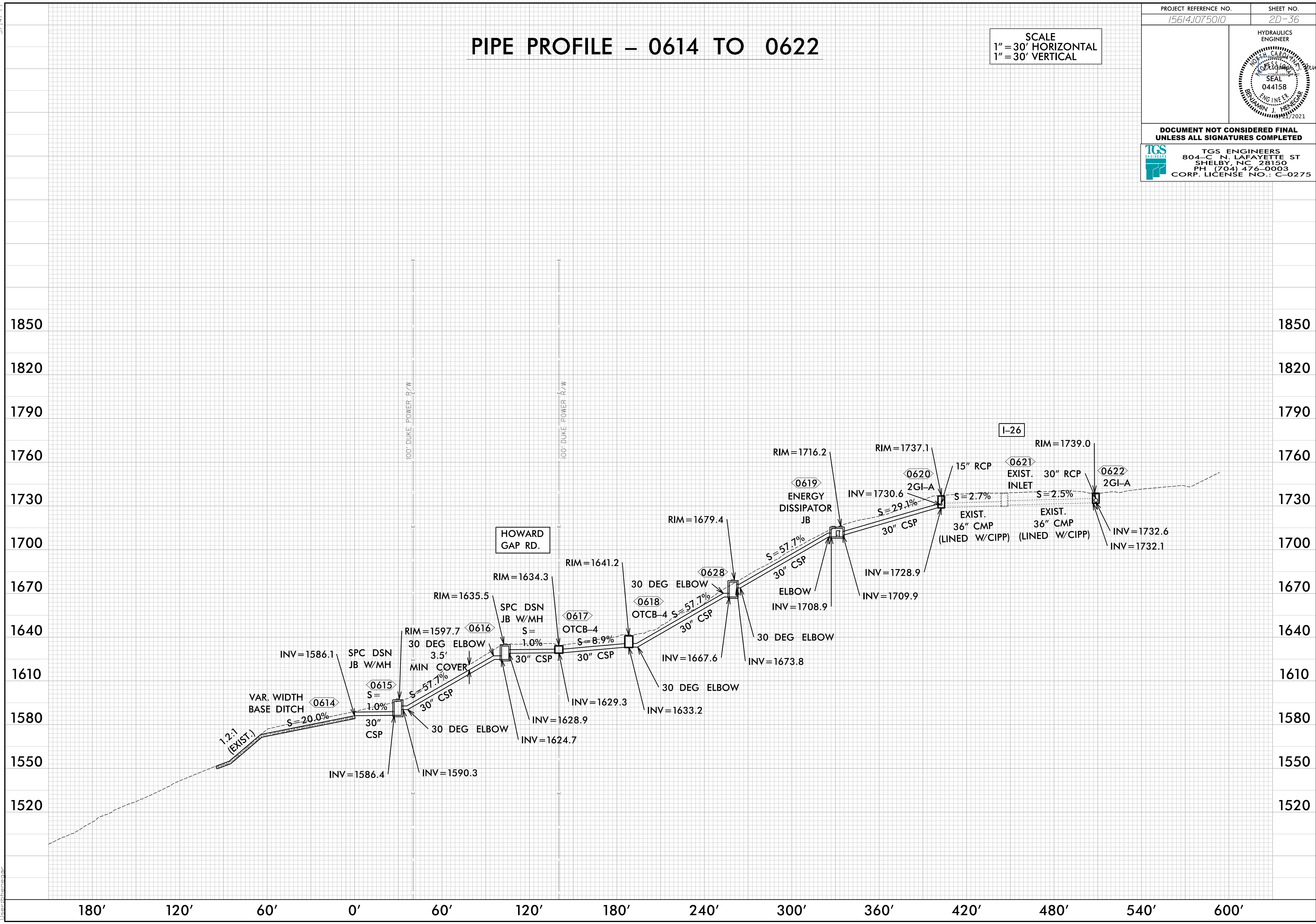

COMPUTED BY: CBP DATE: 3/18/2021
 CHECKED BY: JLT DATE: 5/2/2018

PROJECT NO. SHEET NO.
 15614.1075010 3B-1

STATE OF NORTH CAROLINA DIVISION OF HIGHWAYS

SUMMARY OF EARTHWORK IN CUBIC YARDS

Station	Station	Uncl. Excav. +%	Embank. +%	Borrow	Waste
-I26- 450+50.00, LT	-I26- 477+31.25, LT	1,137	9	0	1,128
-I26- 450+40.00, RT	-I26- 482+65.00, RT	1,653	1,068	0	585
-I26- 483+18.56, CL	-I26- 497+50.00, CL	1,120	115	0	1,005
TOTALS:		3,910	1,192	0	2,718
MATERIAL FOR SHOULDER CONST.					
LOSS DUE TO CLEARING & GRUBBING					
WASTE IN LIEU OF BORROW					
PROJECT TOTALS:		3,910	1,192	0	2,718
EST. 5% TO REPLACE TOP SOIL ON BORROW PIT				0	
GRAND TOTALS:		3,910	1,192	0	2,718
SAY:		4,400		0	

Approximate quantities only. Unclassified excavation, fine grading, clearing and grubbing, and removal of existing pavement will be paid for at the lump sum price for "Grading".

PAVEMENT REMOVAL SUMMARY IN SQUARE YARDS

Survey Line	Station	Station	Location LT/RT/CL	Asphalt Removal	Asphalt Breakup	Concrete Removal	Concrete Breakup
-I26-	450+50	477+31.25	LT	1043.92			
-I26-	450+40	482+65	RT	3865.33			
-I26-	483+18.56	497+50	CL	1664.71			
TOTAL				6,573.96			
SAY				6,580			

SHOULDER BERM GUTTER SUMMARY IN FEET

LINE	STATION	STATION	LOCATION	LENGTH
-I26-	451+00	476+00	LT	2,500.00
			TOTAL	2,500.00
			SAY	2,500

EST. DDE = 3,190 CUBIC YARDS
 EST. SHALLOW UNDERCUT: 100 CY
 EST. SELECT GRANULAR MATERIAL: 400 CY
 GEOTEXTILE FOR SOIL STABILIZATION: 700 SY
 CLASS IV SUBGRADE STABILIZATION: 200 TONS
 PER GEOTECH RECOMMENDATION, ESTIMATED 400 CUBIC YARDS OF UNDERCUT TO BE USED AT THE DISCRETION OF THE RESIDENT ENGINEER.

"N" = DISTANCE FROM EDGE OF LANE TO FACE OF GUARDRAIL
 TOTAL SHOULDER WIDTH = DISTANCE FROM EDGE OF TRAVEL LANE TO SHOULDER BREAK POINT.
 FLARE LENGTH = DISTANCE FROM LAST SECTION OF PARALLEL GUARDRAIL TO END OF GUARDRAIL.
 W = TOTAL WIDTH OF FLARE FROM BEGINNING OF TAPER TO END OF GUARDRAIL.
 G = GATING IMPACT ATTENUATOR TYPE 350
 NG = NON-GATING IMPACT ATTENUATOR TYPE 350

GUARDRAIL SUMMARY IN FEET

LINE	BEG. STA.	END STA.	LOC.	LENGTH (LF)			WARRANT POINT		"N" DIST. FROM E.O.L.	TOTAL SHLDR WIDTH	FLAIR LENGTH		W		ANCHORS (EA)			IMP. ATTEN. TYPE TL-3 EA	REMOVE EXISTING GUARDRAIL (LF)	EXTRA LENGTH POSTS (EA)	REMARKS
				STRAIGHT	SHOP CURVED	DOUBLE FACED	APPR. END	TRAIL. END			APPR. END	TRAIL. END	APPR. END	TRAIL. END	CAT-1	B-77					
-I26-	450+50.00	477+31.25	LT	2,681.25					14'									2681.25	430	Shoulder Berm Gutter; Use Extra Depth Posts	
-I26-	483+18.56	497+50.00	CL, LT	1,431.44					10'									1431.44	230	Use Extra Depth Posts	
-I26-	483+18.56	497+50.00	CL, RT	1,431.44					10'	125'	2.5'							1431.44	230	Use Extra Depth Posts	
-HGR-	34+25.00	36+00.00	LT	175.00														175			
-HGR-	52+00.00	53+25.00	LT	125.00														125			
SUB-TOTALS				5,844.13														5844.13	890		
LESS ANCHOR DEDUCTIONS																					
	CAT-1	1@6.25 ft		6.25																	
	B-77	1@22.875 ft		22.88																	
ANCHOR TOTALS				29.13																	
GRAND-TOTALS				5,815.01															5844.13	890	
SAY				5,825															5850	890	

ADDITIONAL GUARDRAIL POSTS = 5 EA

TGSBENLAPTOP

COMPUTED BY: BAC DATE: 04-20-21
CHECKED BY: BJH DATE: 04-20-21

PROJECT NO. SHEET NO.
15614.1075010 3D-1

NORTH CAROLINA DEPARTMENT OF TRANSPORTATION
DIVISION OF HIGHWAYS

Note: Invert Elevations indicated are for Bid Purposes only and shall not be used for project construction stakeout.
See "Standard Specifications For Roads and Structures, Section 300-5".

LIST OF PIPES, ENDWALLS, ETC. (FOR PIPES 48 INCHES & UNDER)

Main data table with columns for Line & Station, Offset, Structure Number, Invert Elevation, Pipe Size, Pipe Material (C.S. PIPE, R.C. PIPE), Pipe Type (15" to 48" CIPP LINER), Quantities for Drainage Structures, Frame/Grates/Hood, and Remarks. Includes a SHEET TOTALS row at the bottom.

ABBREVIATIONS table listing symbols and their corresponding materials or components like C.A.A. CORRUGATED ALUMINUM ALLOY, C.B. CATCH BASIN, etc.

REMARKS

COMPUTED BY: JCK Jan-21
 CHECKED BY: SCC Jan-21

(5-15-18)

PROJECT NO. SHEET NO.
 15614.1075010 3G-1

**STATE OF NORTH CAROLINA
 DIVISION OF HIGHWAYS**

SUMMARY OF SUBSURFACE DRAINAGE

LINE	Station	Station	Location LT/RT/CL	Drain Type* UD/BD/SD	LF
L	453+00	461+00	RT	SD	800
L	452+00	460+75	LT	SD	875
L	463+00	468+00	LT	SD	500
L	463+00	475+00	RT	SD	1200
L	470+00	472+75	LT	SD	275
L	477+00	481+50	RT	SD	450
L	483+00	497+00	CL	SD	1400
CONTINGENCY					200
TOTAL LF:					5700

*UD = Underdrain
 *BD = Blind Drain
 *SD = Subsurface Drain

SUMMARY OF AGGREGATE SUBGRADE/STABILIZATION

LINE	Station	Station	Aggregate Type* ASU(1/2)/ AST	Aggregate Thickness INCHES [8" for ASU(2)]	Shallow Undercut CY	Class IV Subgrade Stabilization TONS	Geotextile for Soil Stabilization SY	Stabilizer Aggregate TONS	Class IV Aggregate Stabilization TONS
CONTINGENCY			1	12	100	200	500		
TOTAL CY/TONS/SY:					100	200**	500**	0	0

*ASU(1/2) = Aggregate Subgrade (Type 1 or 2)
 *AST = Aggregate Stabilization
 **Total tons of "Class IV Subgrade Stabilization" and total square yards of "Geotextile for Soil Stabilization" are only the estimated quantities for ASU(1/2)/AST and may only represent a portion of the subgrade stabilization and geotextile quantities shown in the Item Sheets of the Proposal.

8/17/99

PROJECT REFERENCE NO. 15614.1075010	SHEET NO. 4
RW SHEET NO.	
ROADWAY DESIGN ENGINEER	HYDRAULICS ENGINEER
<p>DOCUMENT NOT CONSIDERED FINAL UNLESS ALL SIGNATURES COMPLETED</p> <p>TGS ENGINEERS 804-C N. LAFAYETTE ST SHELBY, NC 28150 PH (704) 476-0003 CORP. LICENSE NO.: C-0275</p>	

NOTE: ALL CSP GASKETS ARE TO BE SLEEVE GASKETS.

NOTE: EXISTING RIGHT OF WAY IS NOT SHOWN BUT EXTENDS OUTSIDE OF PROJECT LIMITS ON SOUTHERN SIDE OF ALIGNMENT.

-126- CURVE DATA

Pls Sta 415+45.24 θs = 8° 00' 00.0" Ls = 400.00' LT = 266.94' ST = 133.58'	Pls Sta 417+47.11 Δ = 5° 30' 00.0" (RT) D = 4° 00' 00.0" L = 137.50' T = 68.80' R = 1,432.40'	Pls Sta 419+49.38 θs = 8° 00' 00.0" Ls = 400.00' LT = 266.94' ST = 133.58'
Pls Sta 425+36.75 θs = 8° 00' 00.0" Ls = 400.00' LT = 266.94' ST = 133.58'	Pls Sta 428+13.63 Δ = 11° 28' 00.0" (LT) D = 4° 00' 00.0" L = 286.67' T = 143.81' R = 1,432.40'	Pls Sta 430+90.06 θs = 8° 00' 00.0" Ls = 400.00' LT = 266.94' ST = 133.58'

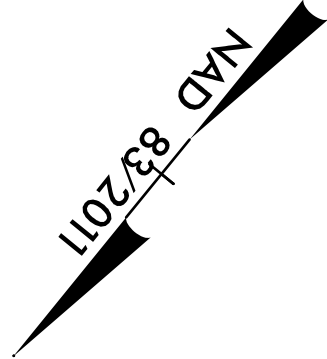
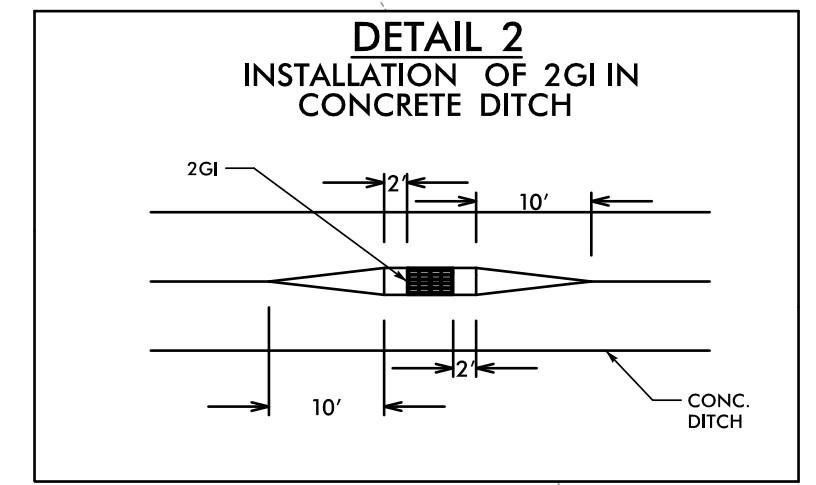

LANDSLIDE OUTLINES - ACTIVE

APPROXIMATE ALLOWABLE WORKING AREA (SEE EC PLANS FOR ADDITIONAL INFORMATION). FINAL LIMITS TO BE SET AS DIRECTED BY THE ENGINEER.

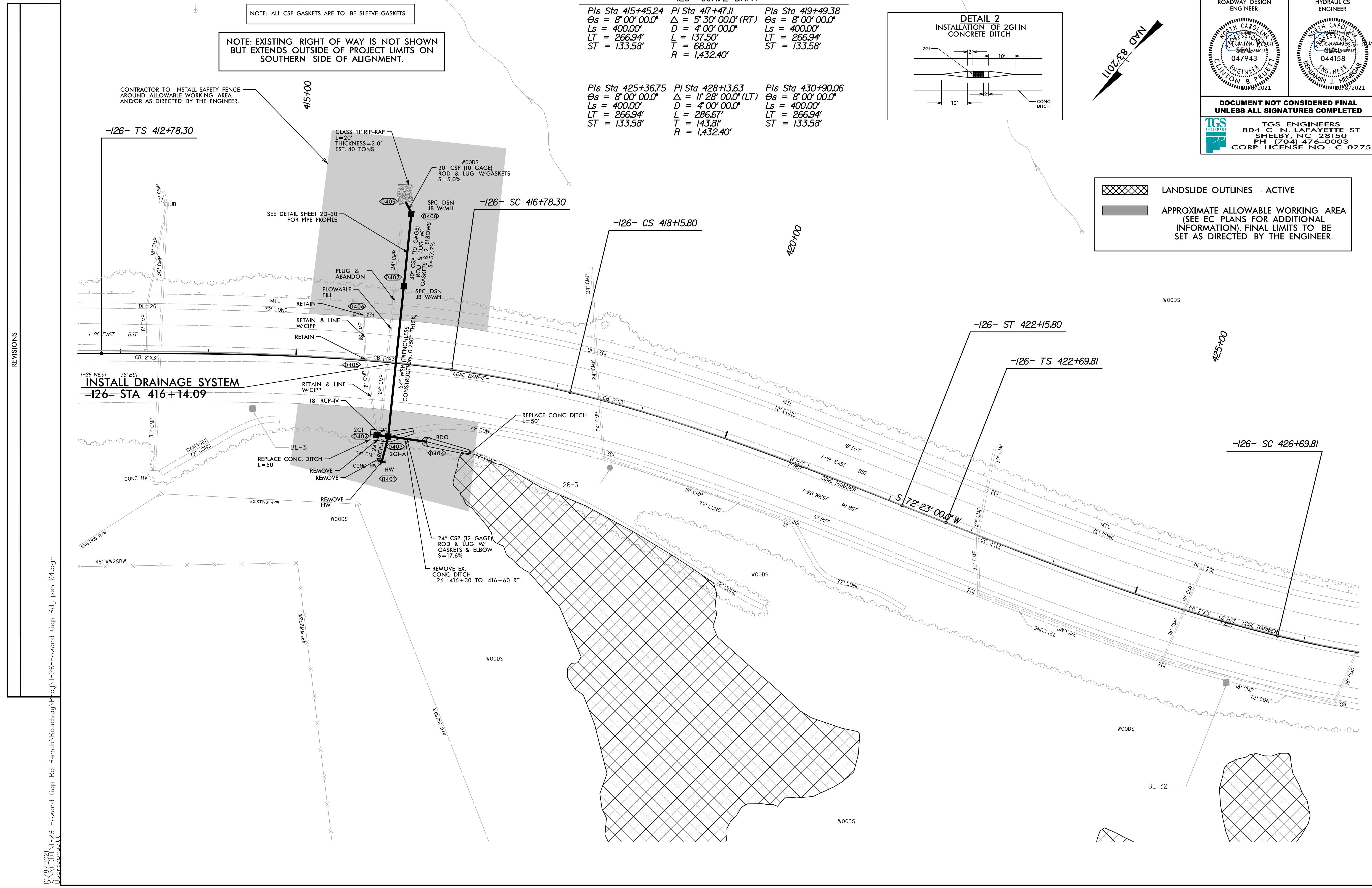

REVISIONS

10/8/2021
X:\NCDD01\1-26 Howard Gap Rd Rehab\Roadway\Project\1-26 Howard Gap.Rdw_psh_04.dgn
User: jstewart

8/17/99

2 JOHN BARNES, III AND ELIZABETH H. BARNES LIVING TRUST DB 306 PG 1841 MAP CARD FILE B PG 1235

MATCH LINE MATCH TO SHEET NO. 9

SA SENSITIVE AREA
LANDSLIDE OUTLINES - ACTIVE

PROJECT REFERENCE NO.	SHEET NO.
15614.1075010	5
RW SHEET NO.	
ROADWAY DESIGN ENGINEER	HYDRAULICS ENGINEER
DOCUMENT NOT CONSIDERED FINAL UNLESS ALL SIGNATURES COMPLETED	
TGS ENGINEERS 804-C N. LAFAYETTE ST SHELBY, NC 28150 PH (704) 476-0003 CORP. LICENSE NO.: C-0275	

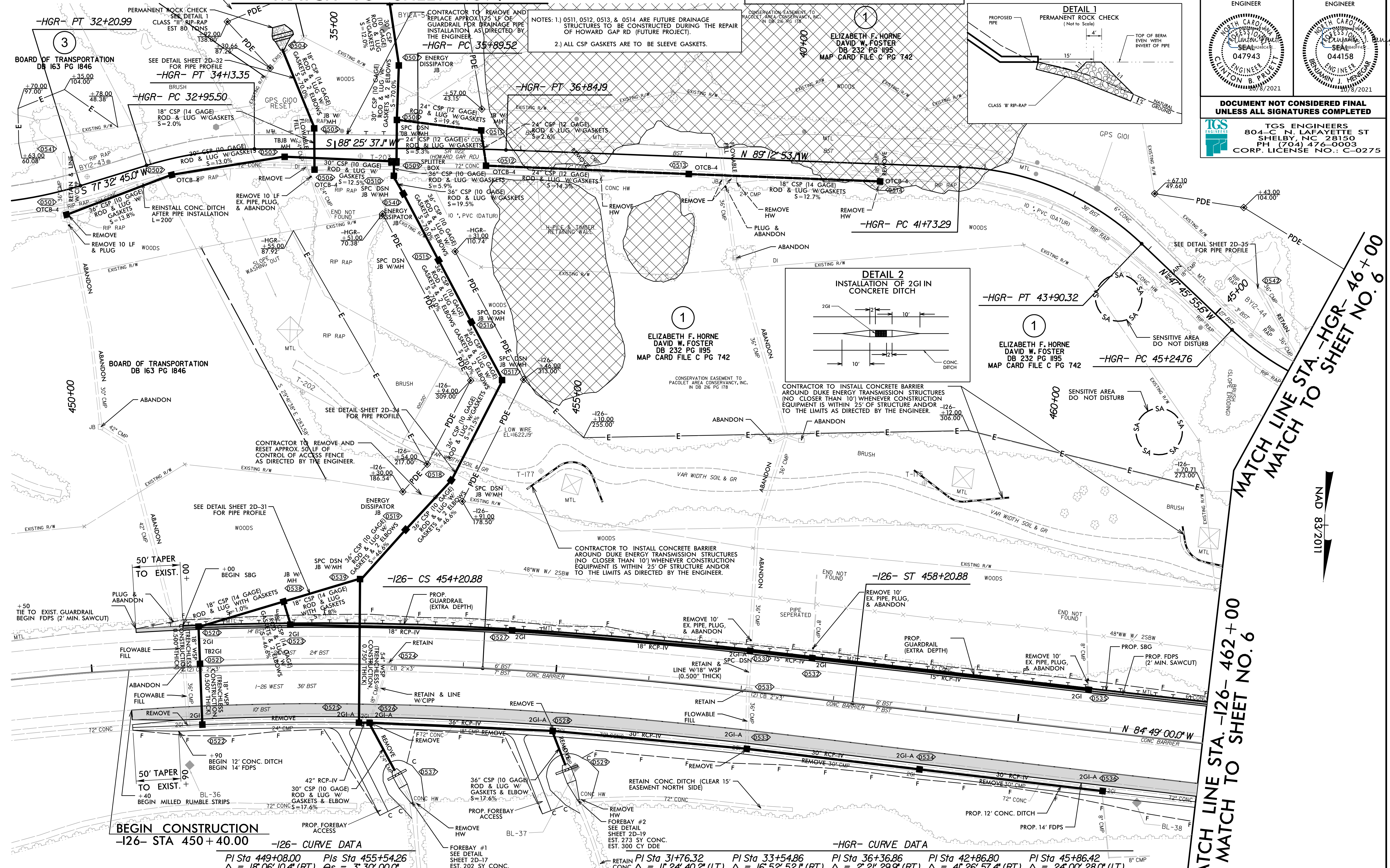

ALL DUKE TRANSMISSION LINES ARE TO BE TREATED WITH CLEARANCE AND OFFSET GUIDELINES AS ESTABLISHED FOR 100KV POWERED RATING.

BEGIN CONSTRUCTION
-126- STA 450+40.00

-126- CURVE DATA

PI Sta 449+08.00	PIs Sta 455+54.26
$\Delta = 18^{\circ} 06' 10.4" (RT)$	$\Delta = 3^{\circ} 30' 00.0"$
$D = 1^{\circ} 45' 00.0"$	$Ls = 400.00'$
$L = 1,034.45'$	$LT = 266.72'$
$T = 521.57'$	$ST = 133.38'$
$R = 3,274.05'$	

-HGR- CURVE DATA

PI Sta 31+76.32	PI Sta 33+54.86	PI Sta 36+36.86	PI Sta 42+86.80	PI Sta 45+86.42
$\Delta = 11^{\circ} 24' 40.2" (LT)$	$\Delta = 16^{\circ} 52' 52.1" (RT)$	$\Delta = 2^{\circ} 21' 29.9" (RT)$	$\Delta = 4^{\circ} 26' 57.4" (RT)$	$\Delta = 24^{\circ} 00' 28.0" (LT)$
$D = 12^{\circ} 43' 56.6"$	$D = 14^{\circ} 19' 26.2"$	$D = 2^{\circ} 29' 28.0"$	$D = 19^{\circ} 05' 54.9"$	$D = 19^{\circ} 45' 25.8"$
$L = 89.62'$	$L = 117.85'$	$L = 117.03'$	$L = 121.51'$	$L = 121.51'$
$T = 44.96'$	$T = 59.36'$	$T = 47.34'$	$T = 113.51'$	$T = 61.66'$
$R = 450.00'$	$R = 400.00'$	$R = 2,300.00'$	$R = 300.00'$	$R = 290.00'$

MATCH LINE STA. -126- 462+00 MATCH TO SHEET NO. 6

MATCH LINE STA. -HGR- 46+00 MATCH TO SHEET NO. 6

NAD 83/2011

REVISIONS

10/8/2021 X:\NCDDOT\1-26 Howard Gap Rd Rehab Roadway Proj\1-26-Howard Gap_Rdy_psh_05.dgn

PROJECT REFERENCE NO. 15614.1075010	SHEET NO. 6
RW SHEET NO.	
ROADWAY DESIGN ENGINEER	HYDRAULICS ENGINEER
DOCUMENT NOT CONSIDERED FINAL UNLESS ALL SIGNATURES COMPLETED	
TGS ENGINEERS 804-C N. LAFAYETTE ST SHELBY, NC 28150 PH: (704) 476-0003 CORP. LICENSE NO.: C-0275	

ALL DUKE TRANSMISSION LINES ARE TO BE TREATED WITH CLEARANCE AND OFFSET GUIDELINES AS ESTABLISHED FOR 100KV POWERED RATING.

LANDSLIDE OUTLINES - ACTIVE

APPROXIMATE ALLOWABLE WORKING AREA (SEE EC PLANS FOR ADDITIONAL INFORMATION). FINAL LIMITS TO BE SET AS DIRECTED BY THE ENGINEER.

-HGR- CURVE DATA

PI Sta 45+86.42 Δ = 24° 00' 28.0" (LT) D = 19' 45' 25.8" L = 121.51' T = 61.66' R = 290.00'	PI Sta 50+90.24 Δ = 10° 08' 44.8" (LT) D = 5' 06' 56.5" L = 198.33' T = 99.42' R = 1,120.00'	PI Sta 53+74.76 Δ = 13° 18' 26.3" (RT) D = 6' 44' 26.4" L = 197.42' T = 99.16' R = 850.00'	PI Sta 56+52.71 Δ = 12° 50' 07.5" (LT) D = 5' 37' 02.0" L = 228.50' T = 114.73' R = 1,020.00'
--	---	---	--

-I26- CURVE DATA

PIs Sta 466+13.01 Θs = 0° 30' 00.0" Ls = 200.00' LT = 133.33' ST = 66.67'	PI Sta 469+36.39 Δ = 2° 34' 00.0" (LT) D = 0° 30' 00.0" L = 513.33' T = 256.71' R = 11,459.16'	PIs Sta 472+59.68 Θs = 0° 30' 00.0" Ls = 200.00' LT = 133.33' ST = 66.67'
---	---	---

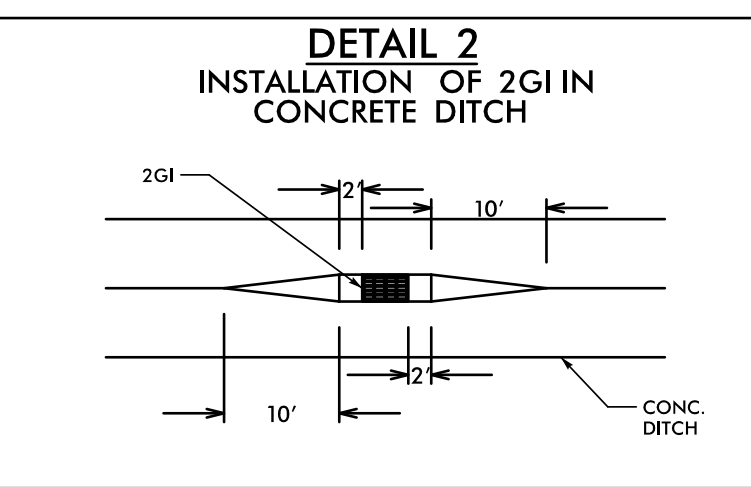

NOTE: ALL CSP GASKETS ARE TO BE SLEEVE GASKETS.

ELIZABETH F. HORNE
DAVID W. FOSTER
DB 232 PG 195
MAP CARD FILE C PG 742

ELIZABETH F. HORNE
DAVID W. FOSTER
DB 232 PG 195
MAP CARD FILE C PG 742

ELIZABETH F. HORNE
DAVID W. FOSTER
DB 232 PG 195
MAP CARD FILE C PG 742

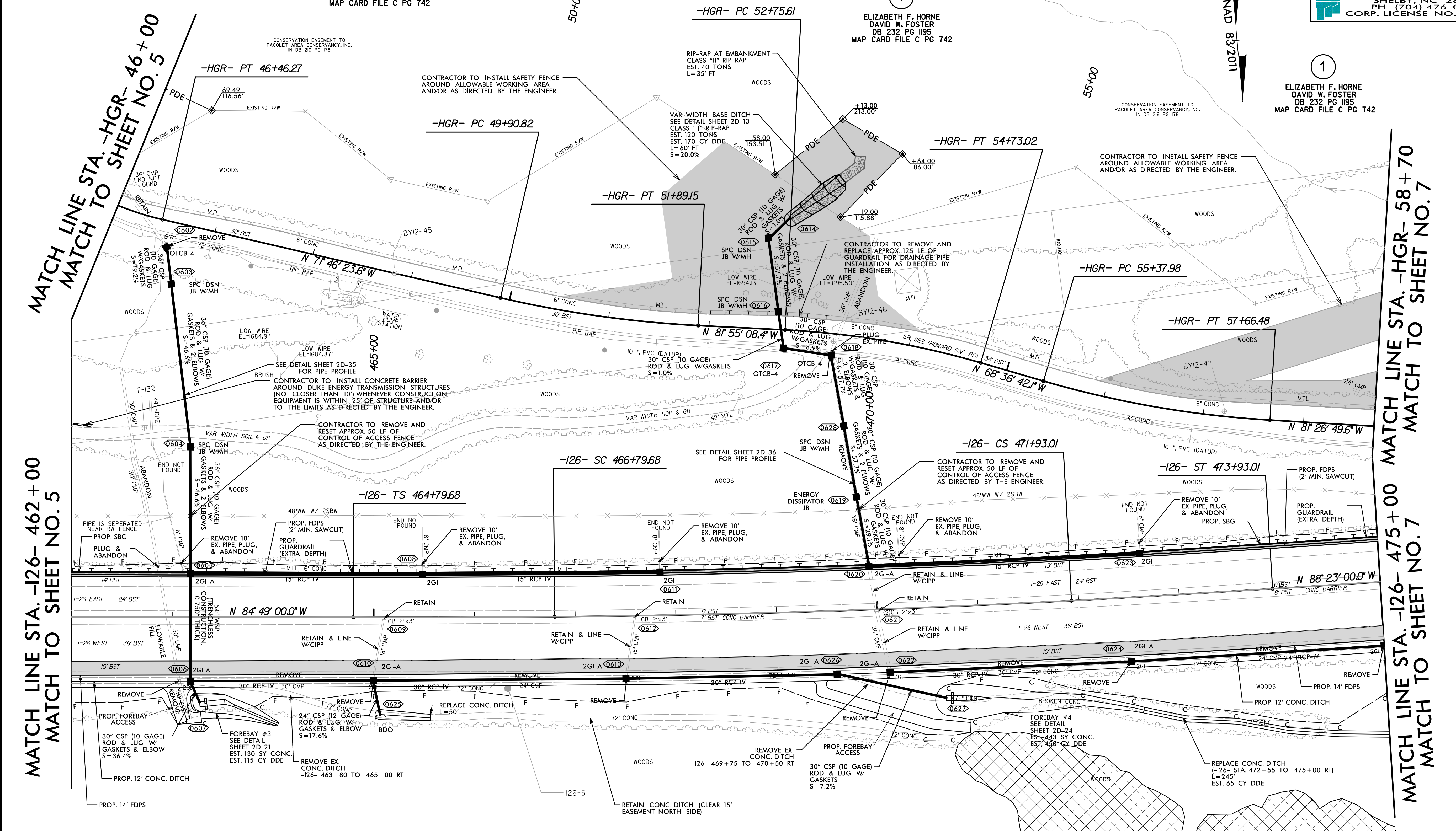

MATCH LINE STA. -I26- 462+00
MATCH TO SHEET NO. 5

MATCH LINE STA. -HGR- 58+70
MATCH TO SHEET NO. 7

REVISIONS

10/17/2021
X:\NCDDT I-26 Howard Gap Rd Rehab\Roadway\Proj\I-26-Howard Gap_Rdy_psh_06.dgn

PROJECT REFERENCE NO. 15614.1075010	SHEET NO. 7
RW SHEET NO.	
ROADWAY DESIGN ENGINEER	HYDRAULICS ENGINEER
DOCUMENT NOT CONSIDERED FINAL UNLESS ALL SIGNATURES COMPLETED	
TGS ENGINEERS 804-C N. LAFAYETTE ST SHELBY, NC 28150 PH: (704) 476-0003 CORP. LICENSE NO.: C-0275	

-I26- CURVE DATA

PIs Sta 477+79.15 θs = 8° 00' 00.0" Ls = 400.00' LT = 266.94' ST = 133.58'	PI Sta 479+97.10 Δ = 6° 47' 00.0" (RT) D = 4° 00' 00.0" L = 169.58' T = 84.89' R = 1,432.39'	PIs Sta 482+15.38 θs = 8° 00' 00.0" Ls = 400.00' LT = 266.94' ST = 133.58'	PIs Sta 487+91.25 θs = 4° 30' 00.0" Ls = 300.00' LT = 200.06' ST = 100.06'
--	---	--	--

-HGR- CURVE DATA

PI Sta 61+19.38 Δ = 9° 40' 19.5" (LT) D = 3° 53' 51.6" L = 248.15' T = 124.37' R = 1,470.00'	PI Sta 66+64.68 Δ = 26° 18' 14.6" (RT) D = 4° 22' 25.4" L = 601.41' T = 306.10' R = 1,310.00'	PI Sta 71+11.33 Δ = 10° 00' 42.7" (LT) D = 19° 05' 54.9" L = 52.42' T = 26.28' R = 300.00'	PI Sta 71+73.19 Δ = 39° 18' 35.0" (LT) D = 57° 17' 44.8" L = 68.61' T = 35.72' R = 100.00'
---	--	---	---



MATCH LINE STA. -126- 475 + 00 MATCH LINE STA. -HGR- 58 + 70
 MATCH TO SHEET NO. 6 MATCH TO SHEET NO. 6

REVISIONS
 08/17/99
 07/17/2021 X:\NCDD01-1-26 Howard Gap Rd Rehab\Roadway\Plan\1-26 Howard Gap_Rdy_psh_07.dgn
 User:cmbeatt

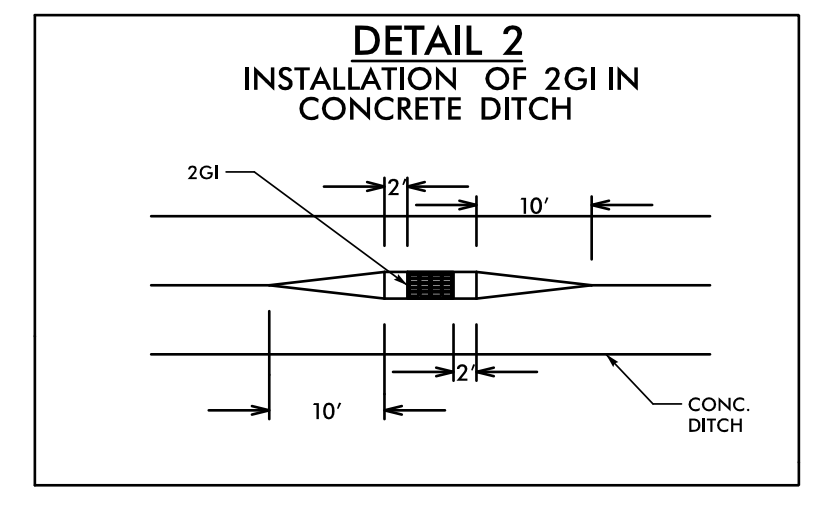
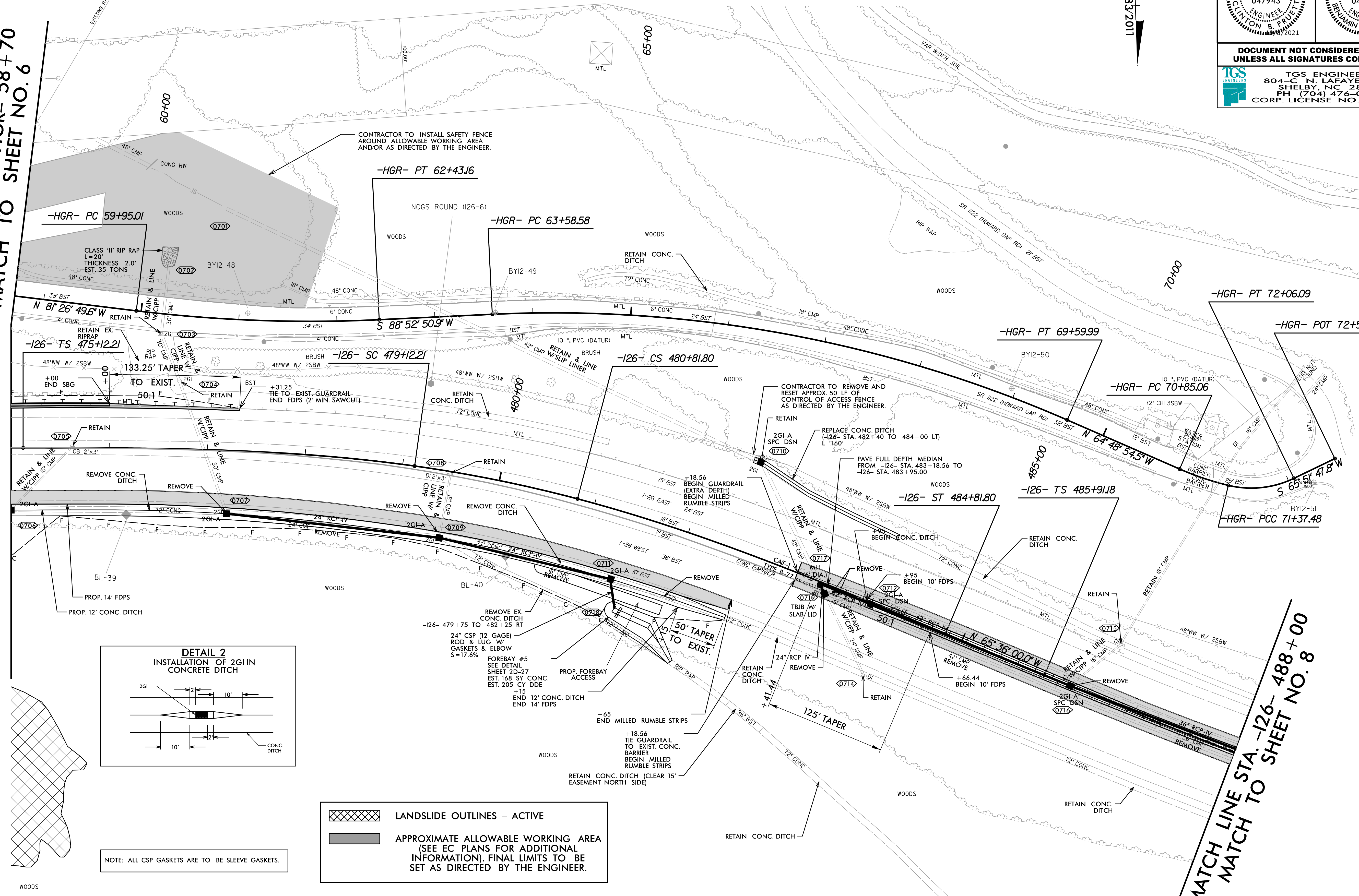

NOTE: ALL CSP GASKETS ARE TO BE SLEEVE GASKETS.

	LANDSLIDE OUTLINES - ACTIVE
	APPROXIMATE ALLOWABLE WORKING AREA (SEE EC PLANS FOR ADDITIONAL INFORMATION). FINAL LIMITS TO BE SET AS DIRECTED BY THE ENGINEER.

8/17/99

PROJECT REFERENCE NO. 156141075010	SHEET NO. 8
RW SHEET NO.	
ROADWAY DESIGN ENGINEER	HYDRAULICS ENGINEER
DOCUMENT NOT CONSIDERED FINAL UNLESS ALL SIGNATURES COMPLETED	
TGS ENGINEERS 804-C N. LAFAYETTE ST SHELBY, NC 28150 PH (704) 476-0003 CORP. LICENSE NO.: C-0275	

-I26- CURVE DATA

Pls Sta 487+91.25	PI Sta 488+92.02	Pls Sta 489+92.91
$\theta_s = 4' 30'' 00.0''$	$\Delta = 0' 03'' 00.0''$ (LT)	$\theta_s = 4' 30'' 00.0''$
$L_s = 300.00'$	$D = 3' 00'' 00.0''$	$L_s = 300.00'$
$LT = 200.06'$	$L = 1.67'$	$LT = 200.06'$
$ST = 100.06'$	$T = 0.83'$	$ST = 100.06'$
	$R = 1,909.86'$	

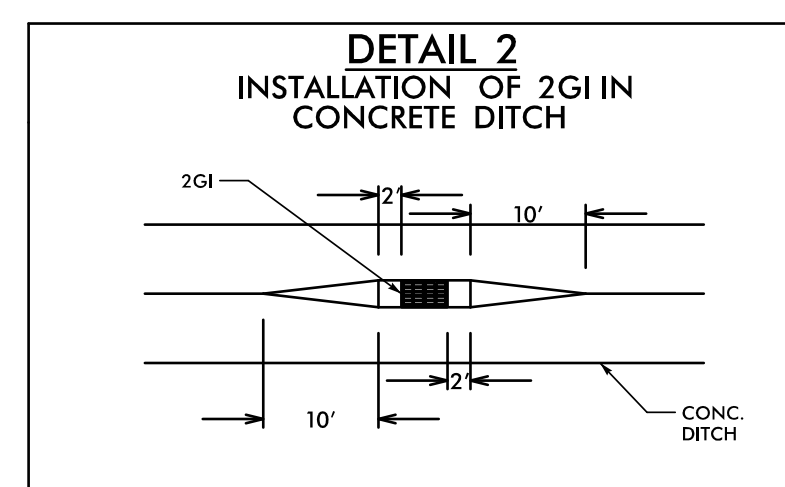

500+00

MATCH LINE STA. -I26- 488+00
MATCH TO SHEET NO. 7

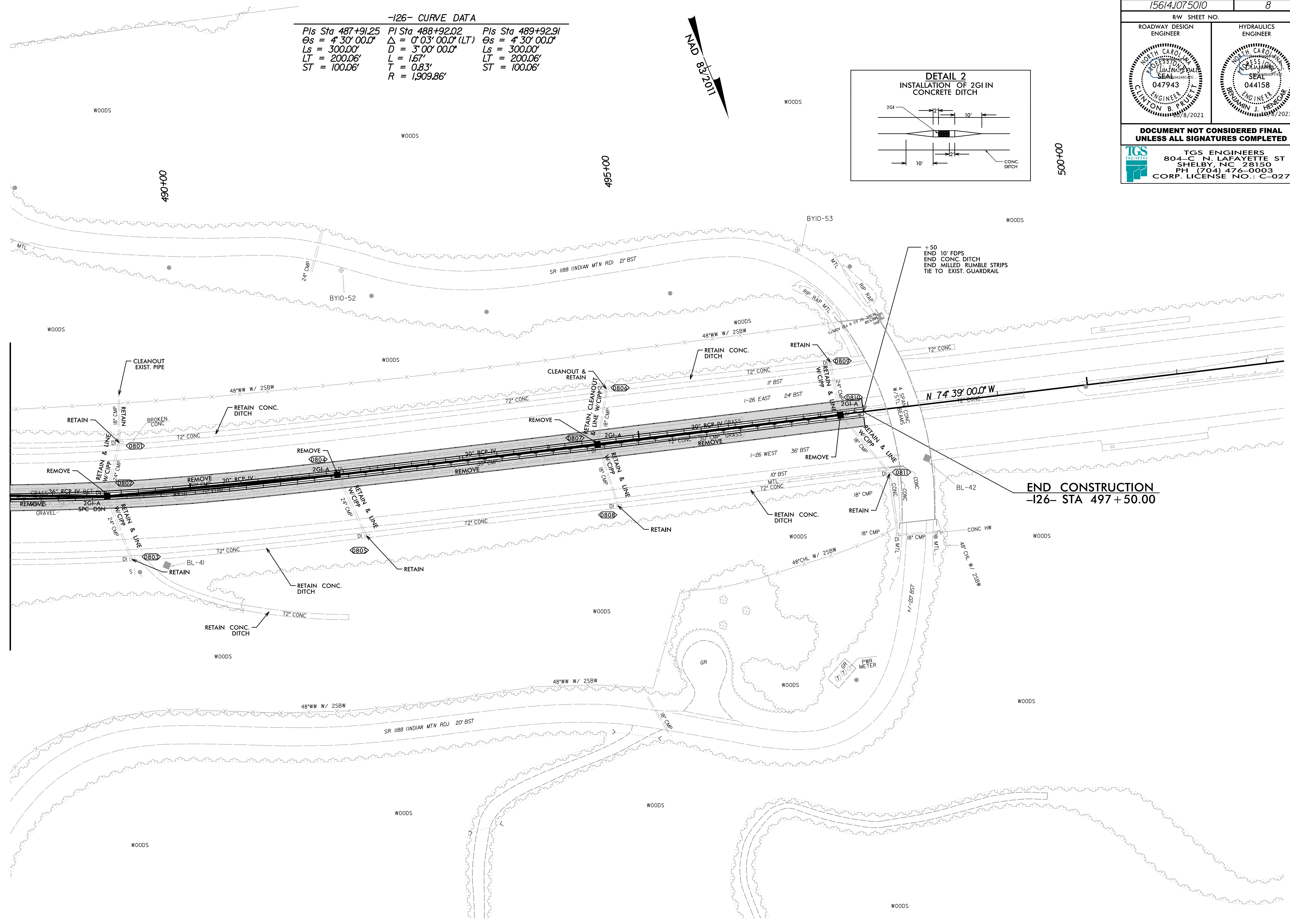

END CONSTRUCTION
-I26- STA 497+50.00

REVISIONS



10/7/2021
 X:\NCDD01-1-26 Howard Gap Rd Rehab\Roadway\Proj\1-26 Howard Gap_Rdy_psh_08.dgn
 User:cmuett



8/17/99

ALL EASEMENTS ON THIS SHEET ARE MEASURED FROM -HGR- ALIGNMENT.

NOTE: ALL CSP GASKETS ARE TO BE SLEEVE GASKETS.

NAD 83/2011

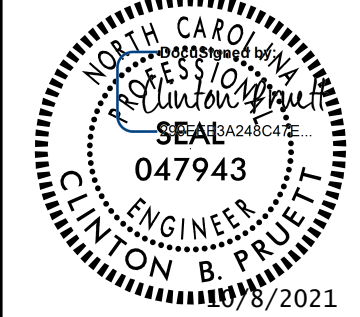
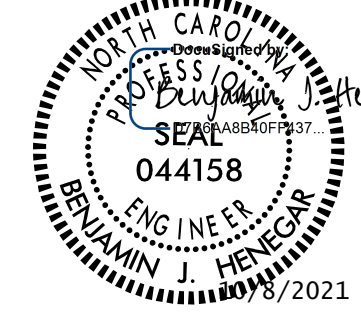
 LANDSLIDE OUTLINES - ACTIVE
 APPROXIMATE CLEARING LIMITS (SEE EC PLANS FOR ADDITIONAL INFORMATION). FINAL LIMITS TO BE SET AS DIRECTED BY THE ENGINEER.

PROJECT REFERENCE NO. 15614.1075010	SHEET NO. 9
RW SHEET NO.	
ROADWAY DESIGN ENGINEER	HYDRAULICS ENGINEER
 JOHN BARNES, III PROFESSIONAL ENGINEER SEAL 047943 EXPIRES 12/31/2021	 BENJAMIN J. HENEGAR PROFESSIONAL ENGINEER SEAL 044158 EXPIRES 12/31/2021
DOCUMENT NOT CONSIDERED FINAL UNLESS ALL SIGNATURES COMPLETED	
 TGS ENGINEERS 804-C N. LAFAYETTE ST SHELBY, NC 28150 PH (704) 476-0003 CORP. LICENSE NO.: C-0275	

REVISIONS

10/7/2021 X:\NCDDOT\1-26 Howard Gap Rd Rehab\Roadway\Plan\1-26-Howard Gap_Rdy_psh_09.dgn

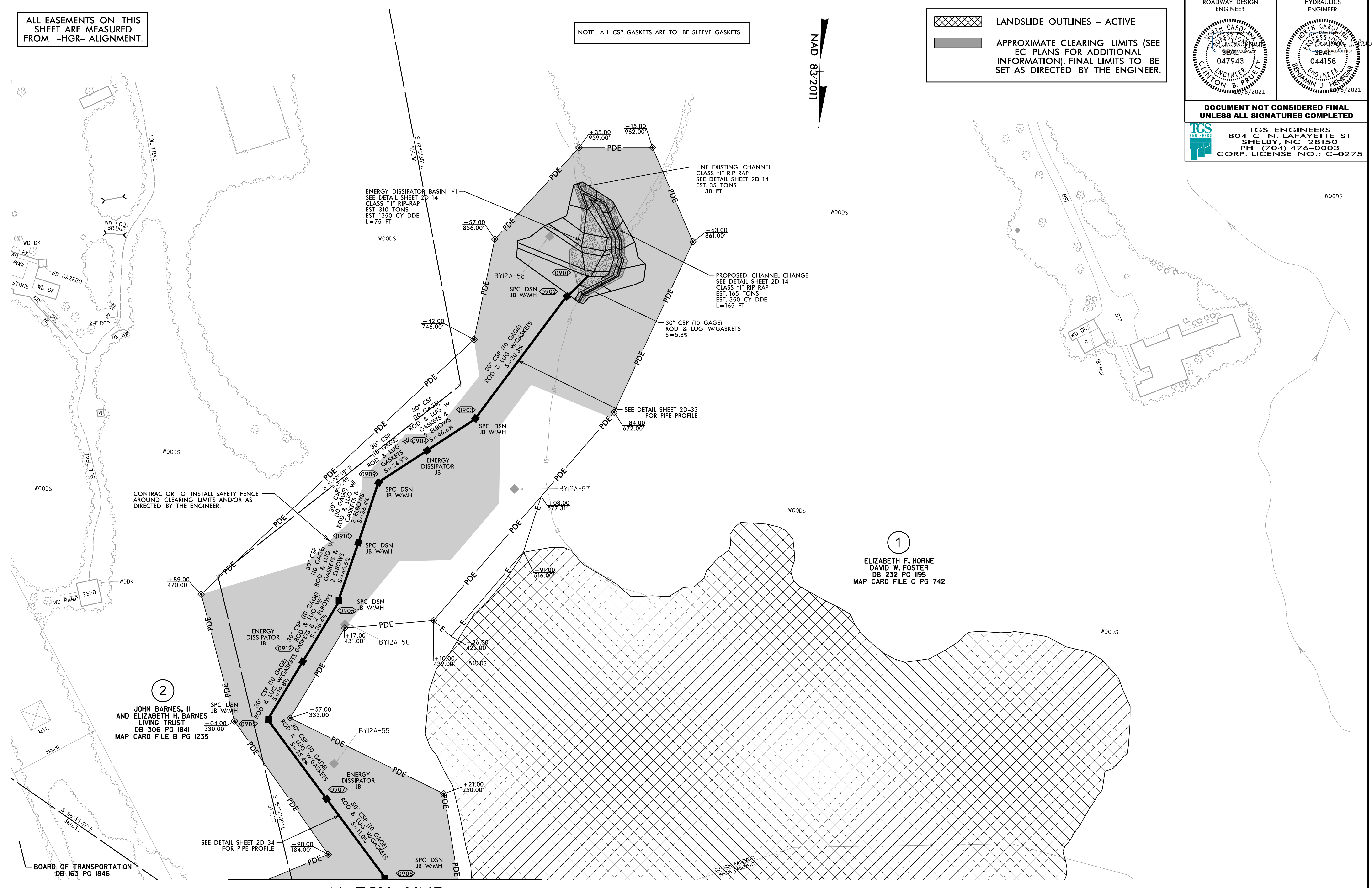

2
 JOHN BARNES, III
 AND ELIZABETH H. BARNES
 LIVING TRUST
 DB 306 PG 1841
 MAP CARD FILE B PG 1235

1
 ELIZABETH F. HORNE
 DAVID W. FOSTER
 DB 232 PG 1195
 MAP CARD FILE C PG 742

MATCH LINE
MATCH TO SHEET NO. 5