

09/08/99

TIP PROJECT: B-5666

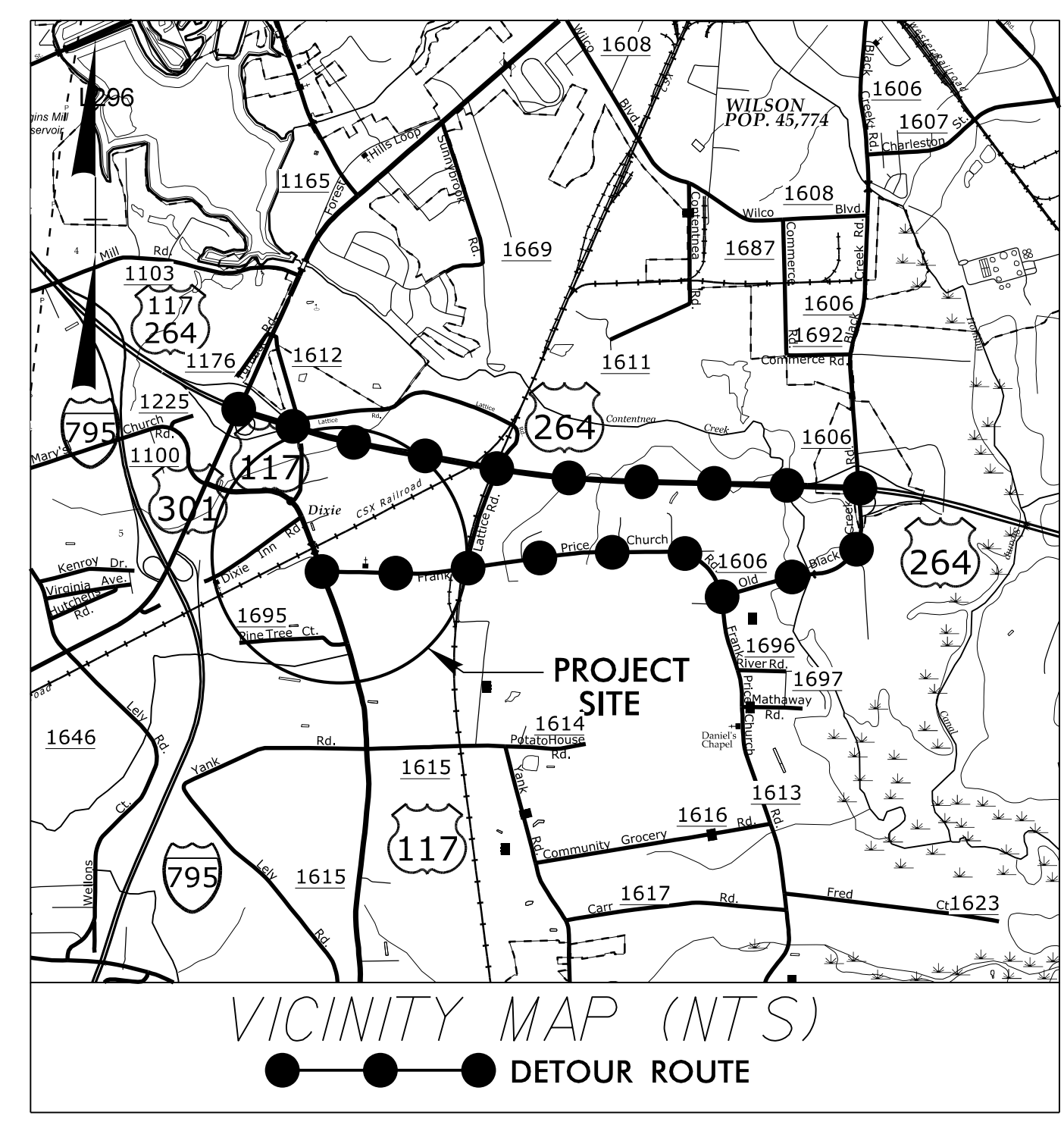

STATE OF NORTH CAROLINA  
DIVISION OF HIGHWAYS

**UTILITIES BY OTHERS PLANS  
WILSON COUNTY**

LOCATION: REPLACE BRIDGE NO. 47 OVER  
SCL RAILROAD ON US 117

TYPE OF WORK: RELOCATION OF U/G COMMUNICATION LINES  
& AERIAL POWER LINES

T.I.P. NO.	SHEET NO.
B-5666	UO-1

NOTE:  
ALL UTILITY WORK SHOWN ON THIS SHEET WILL BE DONE BY OTHERS. NO PAYMENT WILL BE MADE TO THE CONTRACTOR FOR UTILITY WORK SHOWN ON THIS SHEET.

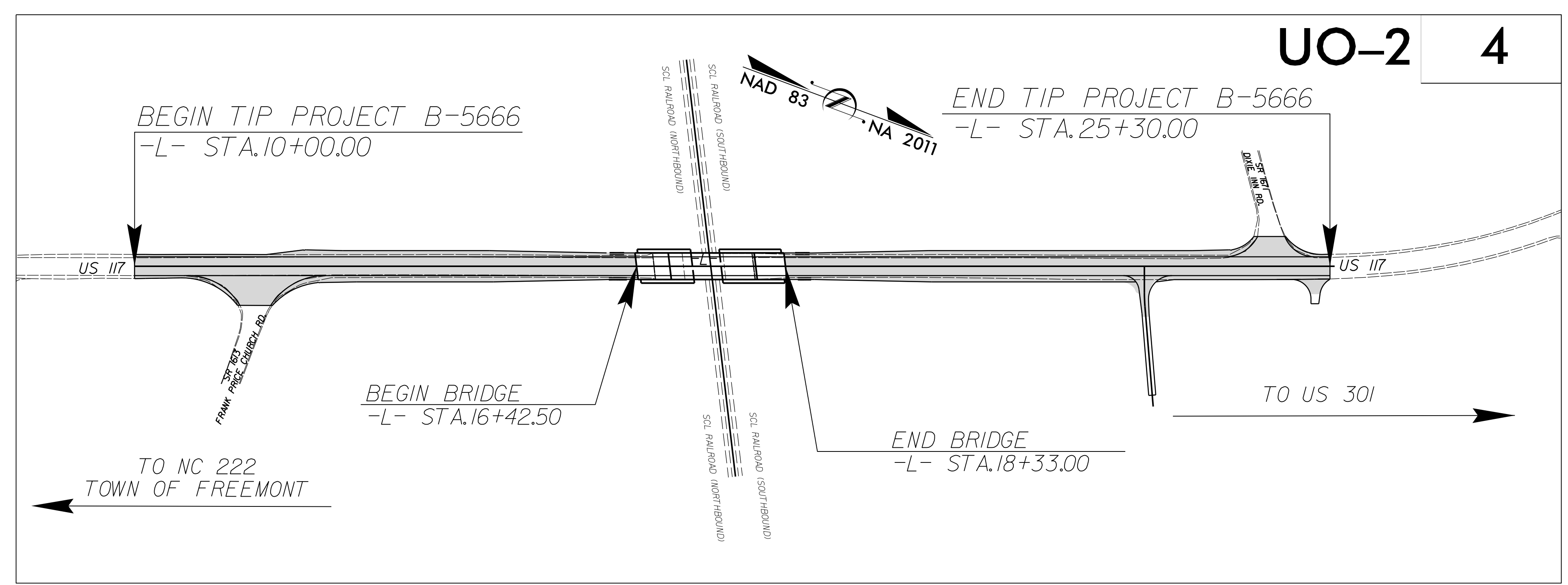

21-APR-2020 09:33  
M:\2018\266609145\22 B-5666\Utilities\290\_001-B-5666\_rdy03\_ut\_01\_psh.dgn  
\$\$\$\$\$USERNAME\$\$\$\$\$

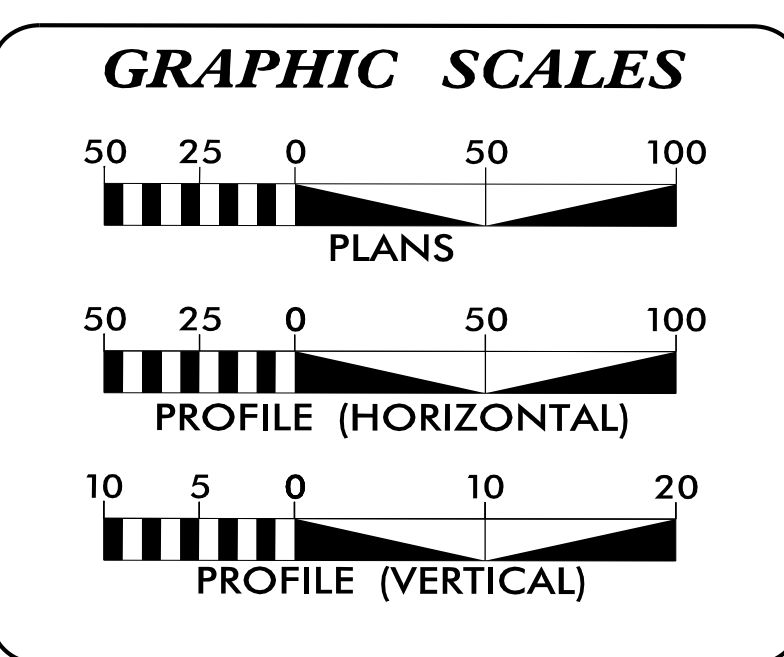

**INDEX OF SHEETS**

SHEET NO.:	DESCRIPTION:
UO-1	TITLE SHEET
UO-2	UBO PLAN SHEET

**UTILITY OWNERS WITH CONFLICTS**

- (A) POWER - TOWN OF BLACK CREEK
- (B) TELEPHONE & FIBER OPTIC - CENTURYLINK
- (C) CABLE TV - CHARTER /SPECTRUM

PREPARED IN THE OFFICE OF:

**KCI**  
KCI Associates of N.C., P.A.  
4505 Falls of Neuse Road, Suite 400  
Raleigh, NC 27609  
Phone (919) 783-9214  
Fax (919) 783-9266

http://www.kei.com

JOHN FAISON PROJECT UTILITY COORDINATOR  
DANIEL ALLEN PROJECT UTILITY DESIGNER

**DIVISION OF HIGHWAYS  
UTILITIES UNIT**  
1555 MAIL SERVICES CENTER  
RALEIGH NC 27699-1555  
PHONE (919) 707-6690  
FAX (919) 250-4151

NABIL HAMDAN REGIONAL UTILITIES ENGINEER  
KYLE PLEASANT UTILITIES AREA COORDINATOR  
KIFAH KAMIL SENIOR UTILITIES ENGINEER  
LARRY JAMES JR. SENIOR UTILITIES COORDINATOR

### UTILITIES BY OTHERS

ALL PROPOSED UTILITY WORK SHOWN ON THIS SHEET WILL BE DONE BY OTHERS. NO PAYMENT WILL BE MADE TO THE CONTRACTOR FOR PROPOSED UTILITY WORK SHOWN ON THIS SHEET.

TOWN OF BLACK CREEK TO SET 50' OR 55' POLES TO ACCOMMODATE 35' RAILROAD CLEARANCE. CHARTER TO ATTACH TO TOWN OF BLACK CREEK POLES.

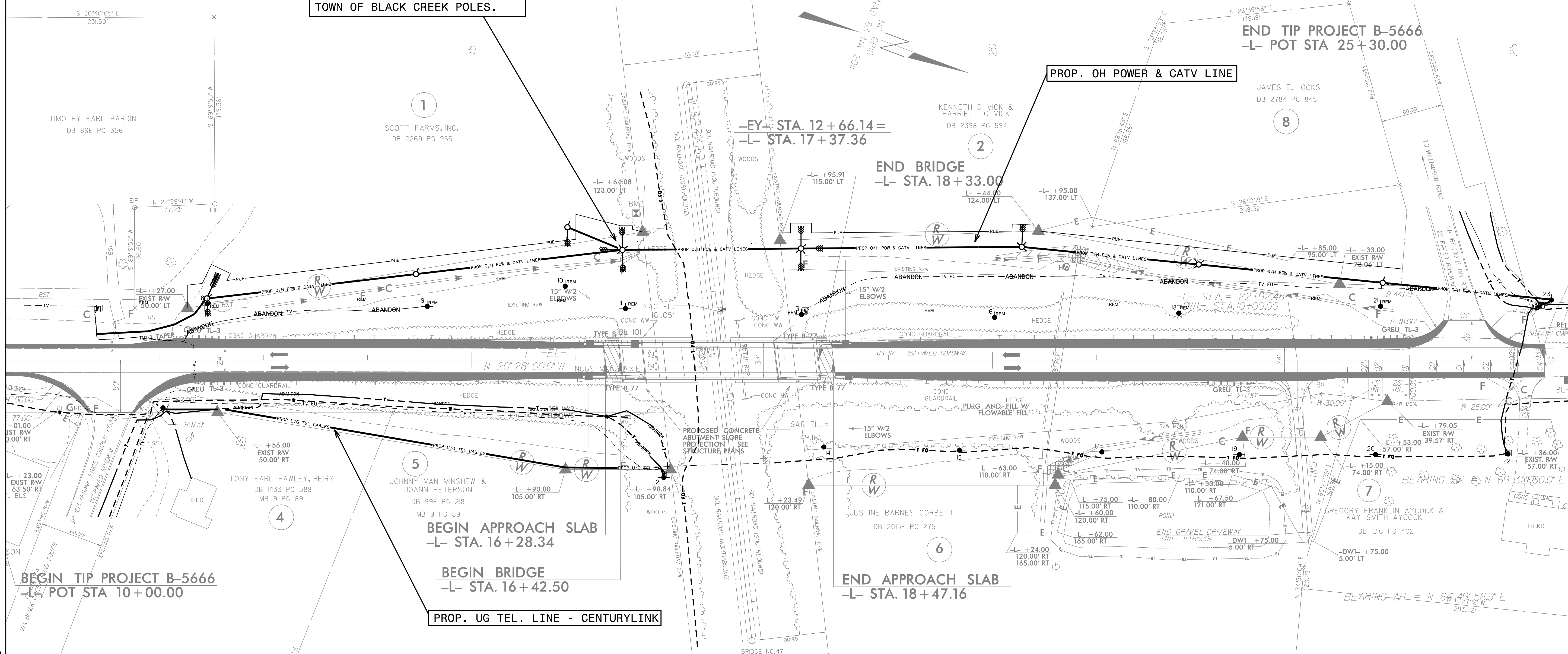

5/14/99

1019145 21-11-PR-2020 09:38  
 \\sbsu01\server\proj\04-ut-02-psh.dgn  
 1019145 21-11-PR-2020 09:38