

PROJECT REFERENCE NO. 15614.1075010	SHEET NO. EC-14/CONST.8
RW SHEET NO.	HYDRAULICS ENGINEER
ROADWAY DESIGN ENGINEER	
 <b>TGS ENGINEERS</b> 706 HILLSBOROUGH ST SUITE 200 RALEIGH, NC 27603 PH (919) 773-8887 CORP. LICENSE NO.: C-0275	

NOTE:  
PLACE TEMPORARY ROCK SEDIMENT DAMS TYPE - B  
AND TEMPORARY ROCK SILT CHECKS TYPE - A AT  
DRAINAGE OUTLETS.

-126- CURVE DATA

PIs Sta 487+91.25	PI Sta 488+92.02	PIs Sta 489+92.91
$\Theta_s = 4' 30'' 00.0''$	$\Delta = 0' 03'' 00.0''$ (LT)	$\Theta_s = 4' 30'' 00.0''$
$L_s = 300.00'$	$D = 3' 00'' 00.0''$	$L_s = 300.00'$
$LT = 200.06'$	$L = 1.67'$	$LT = 200.06'$
$ST = 100.06'$	$T = 0.83'$	$ST = 100.06'$
	$R = 1,909.86'$	

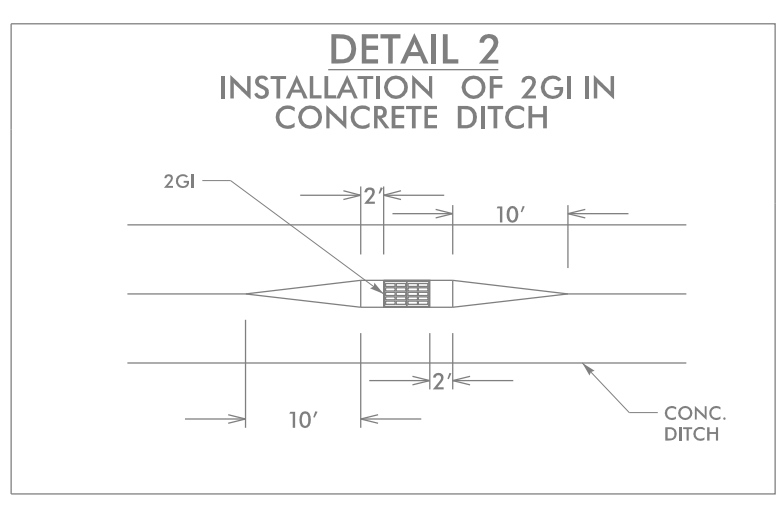
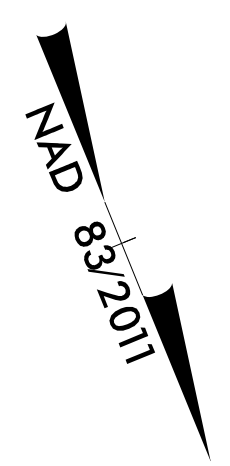

MATCH LINE STA. -126- 488+00  
MATCH TO SHEET NO. 7

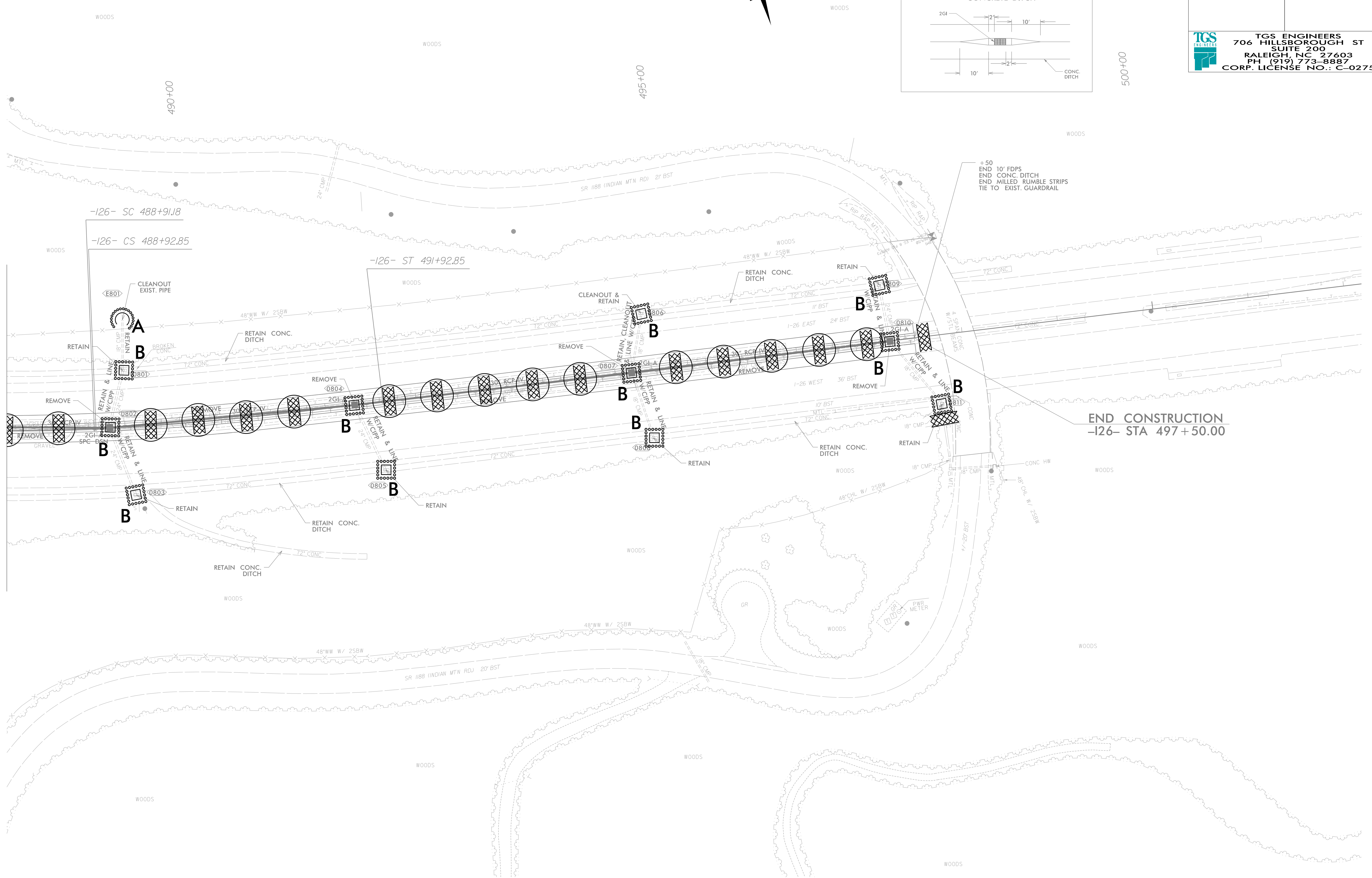

END CONSTRUCTION  
-126- STA 497+50.00