

ECONOLITE ASC/3-2070 OVERLAP PROGRAMMING DETAIL

(program controller as shown)

1. From Main Menu select 2. CONTROLLER
2. From CONTROLLER Submenu select 2. VEHICLE OVERLAPS

OVERLAP A

Select TMG VEH OVLP [A] and 'PPLT FYA'

TMG VEH OVLP...[A] TYPE:PPLT FYA

PROTECTED LEFT TURN.... PHASE 1

OPPOSING THROUGH..... PHASE 2

FLASHING ARROW OUTPUT.....CH9 ISOLATE

DELAY START OF: FYA..0.0 CLEARANCE..0.0

ACTION PLAN SF BIT DISABLE..... 0

Toggle Once

OVERLAP B

Select TMG VEH OVLP [B] and 'PPLT FYA'

TMG VEH OVLP...[B] TYPE:PPLT FYA

PROTECTED LEFT TURN.... PHASE 3

OPPOSING THROUGH..... PHASE 4

FLASHING ARROW OUTPUT.....CH10 ISOLATE

DELAY START OF: FYA..0.0 CLEARANCE..0.0

ACTION PLAN SF BIT DISABLE..... 0

Toggle Once

OVERLAP C

Select TMG VEH OVLP [C] and 'PPLT FYA'

TMG VEH OVLP...[C] TYPE:PPLT FYA

PROTECTED LEFT TURN.... PHASE 5

OPPOSING THROUGH..... PHASE 6

FLASHING ARROW OUTPUT.....CH11 ISOLATE

DELAY START OF: FYA..0.0 CLEARANCE..0.0

ACTION PLAN SF BIT DISABLE..... 0

Toggle Once

OVERLAP D

Select TMG VEH OVLP [D] and 'PPLT FYA'

TMG VEH OVLP...[D] TYPE:PPLT FYA

PROTECTED LEFT TURN.... PHASE 7

OPPOSING THROUGH..... PHASE 8

FLASHING ARROW OUTPUT.....CH12 ISOLATE

DELAY START OF: FYA..0.0 CLEARANCE..0.0

ACTION PLAN SF BIT DISABLE..... 0

Toggle Once

END PROGRAMMING

FYA SIGNAL WIRING DETAIL

(wire signal heads as shown)

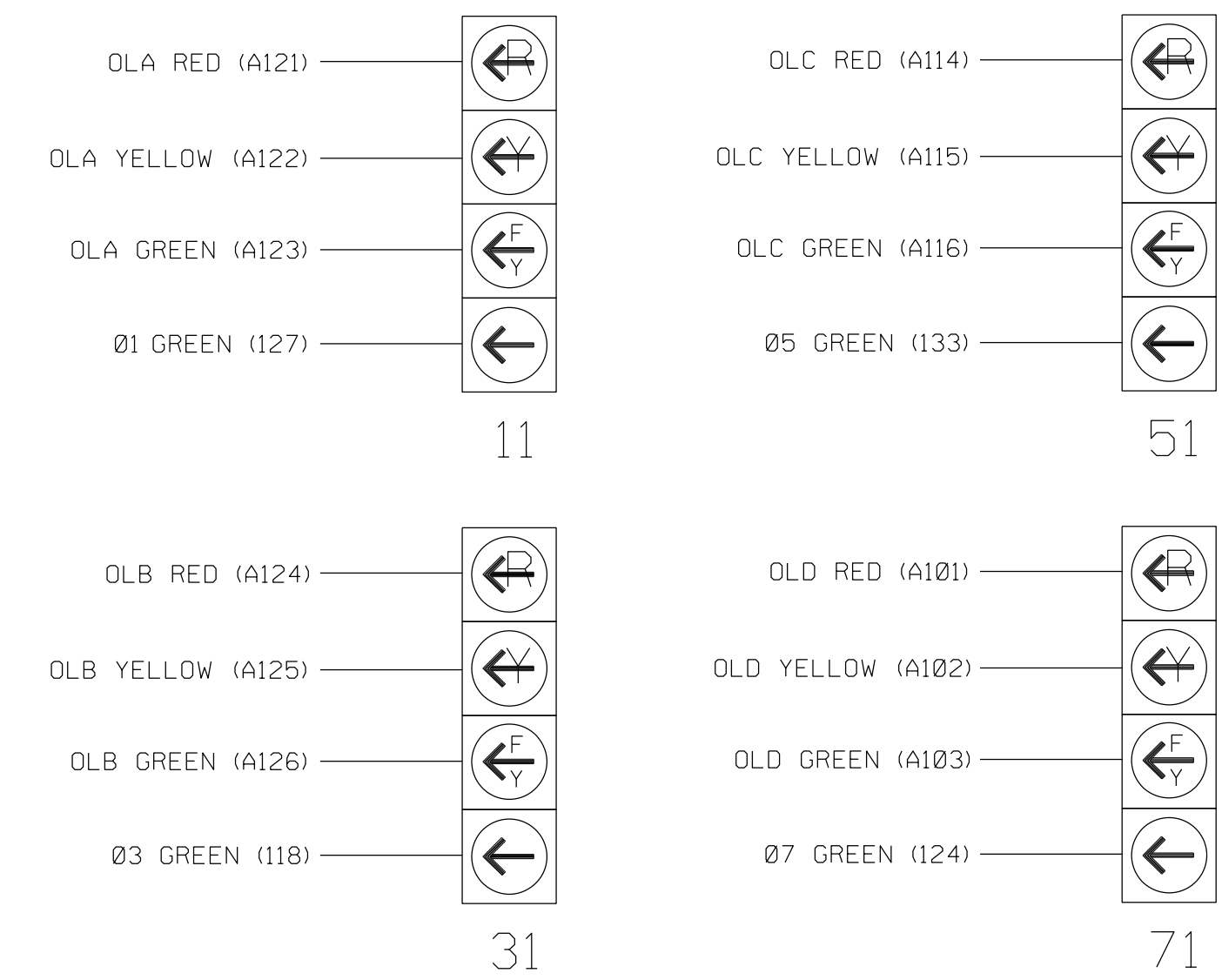

LOAD RESISTOR INSTALLATION DETAIL

(install resistors as shown)

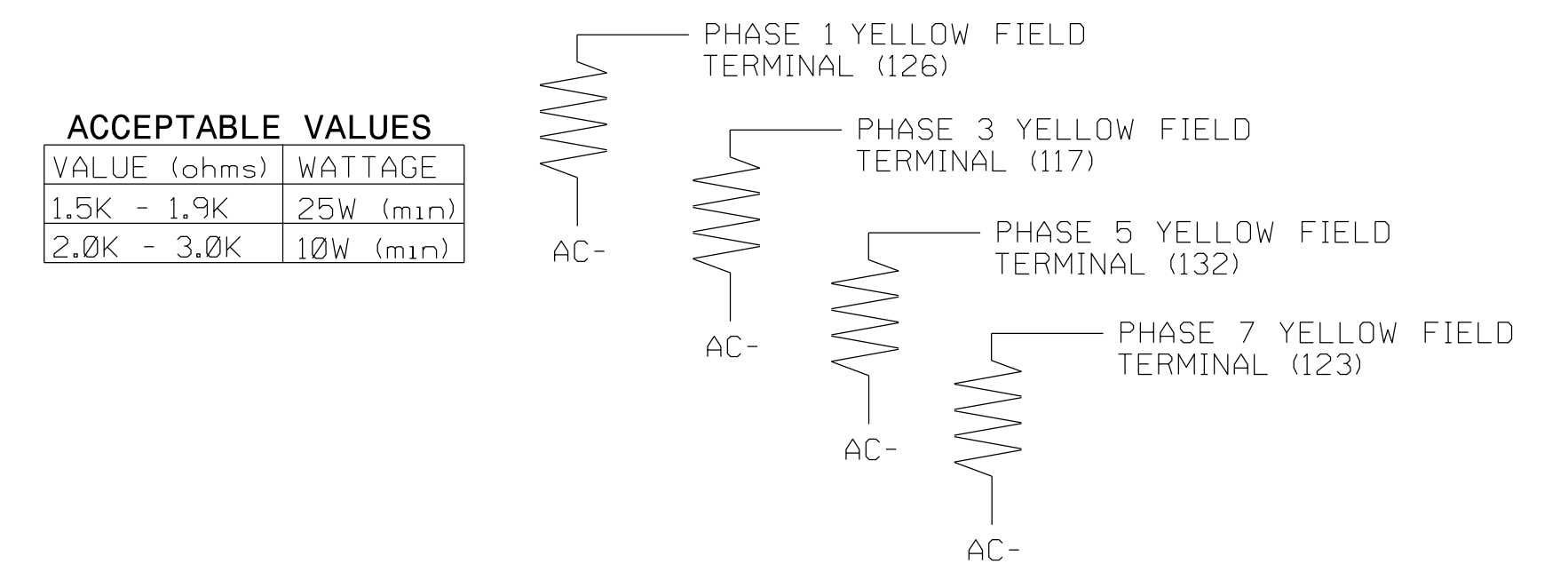

THIS ELECTRICAL DETAIL IS FOR
 THE SIGNAL DESIGN: 01-0004
 DESIGNED: MARCH 2018
 SEALED: 09/20/2018
 REVISED: N/A

20-SEP-2018 18:51
 R:\415942\451\001\4\K05\0001\1\mg01-0004-20180821.e.dgn
 Incon AT CAR-LMDNH-W7



Electrical Detail - Sheet 2 of 4

<p>ELECTRICAL AND PROGRAMMING DETAILS FOR:</p> <p style="font-size: small;">Prepared for the Offices of:</p>	<p>US 158 (Elizabeth Street) at US 17 Bus. (N. Road Street)</p> <p>Divison 1 Pasquotank County Elizabeth City</p> <p>PLAN DATE: March 2018 REVIEWED BY: AJ Davis</p> <p>PREPARED BY: DJ White REVIEWED BY: LM Moon</p>	<p>DOCUMENT NOT CONSIDERED FINAL UNLESS ALL SIGNATURES COMPLETED</p> <p>SEAL</p> <p>DocuSigned by: Lisa M. Moon 9/20/2018 8BC588D83D0421 DATE</p> <p>SIG. INVENTORY NO. 01-0004</p>
---	--	--