

6/2/99

PROJECT REFERENCE NO. <i>BR-0017</i>	SHEET NO. <i>2A-1</i>
ROADWAY DESIGN ENGINEER <i>Douglas M. Weiserman</i>	PAVEMENT DESIGN ENGINEER <i>Cash M. Weiserman</i>
2/24/2021	2/26/2021
DOCUMENT NOT CONSIDERED FINAL UNLESS ALL SIGNATURES COMPLETED	

PAVEMENT SCHEDULE <i>(REVISED FINAL PAVEMENT DESIGN)</i>	
C1	PROP. APPROX. 3" ASPHALT CONCRETE SURFACE COURSE, TYPE S9.5B, AT AN AVERAGE RATE OF 165 LBS. PER SQ. YD. IN EACH OF TWO LAYERS.
C2	PROP. VAR. DEPTH ASPHALT CONCRETE SURFACE COURSE, TYPE S9.5B, AT AN AVERAGE RATE OF 110 LBS. PER SQ. YD. PER 1" DEPTH. TO BE PLACED IN LAYERS NOT TO EXCEED 1.5" IN DEPTH.
D1	PROP. APPROX. 4" ASPHALT CONCRETE SURFACE COURSE, TYPE I19.0C, AT AN AVERAGE RATE OF 456 LBS. PER SQ. YD.
D2	PROP. VAR. DEPTH ASPHALT CONCRETE SURFACE COURSE, TYPE I19.0C, AT AN AVERAGE RATE OF 114 LBS. PER SQ. YD. PER 1" DEPTH. TO BE PLACED IN LAYERS NOT TO EXCEED 4" IN DEPTH.
E1	PROP. APPROX. 4" ASPHALT CONCRETE BASE COURSE, TYPE B25.0C, AT AN AVERAGE RATE OF 456 LBS. PER SQ. YD.
E2	PROP. VAR. DEPTH ASPHALT CONCRETE BASE COURSE, TYPE B25.0C, AT AN AVERAGE RATE OF 114 LBS. PER SQ. YD. PER 1" DEPTH. TO BE PLACED IN LAYERS NOT LESS THAN 4" IN DEPTH OR GREATER THAN 5 1/2" IN DEPTH.
R1	SHOULDER BERM GUTTER
T	EARTH MATERIAL
U	EXISTING PAVEMENT
V	MILLING ASPHALT PAVEMENT, 0" TO 3"
W	VARIABLE DEPTH ASPHALT PAVEMENT (SEE STANDARD WEDGING DETAIL)

NOTE: PAVEMENT EDGE SLOPES ARE 1:1 UNLESS SHOWN OTHERWISE.

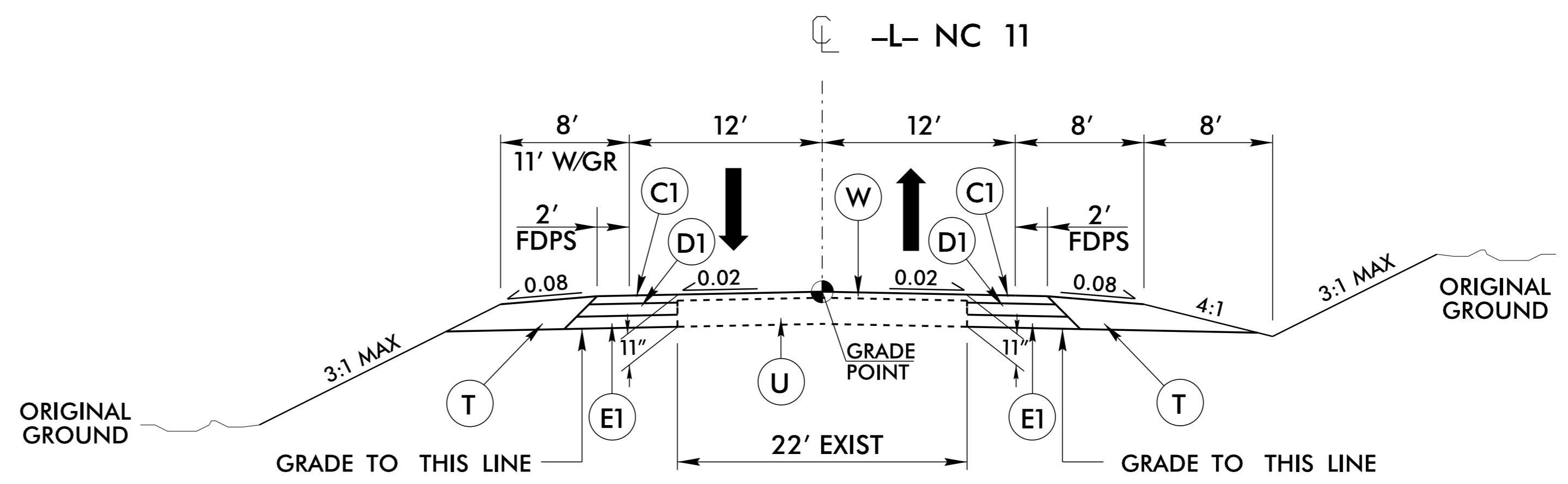

TYPICAL SECTION NO. 1

USE TYPICAL SECTION NO. 1
 -L- STA 14+50.00 TO 16+50.00
 -L- STA 20+30.00 TO STA 22+50.00

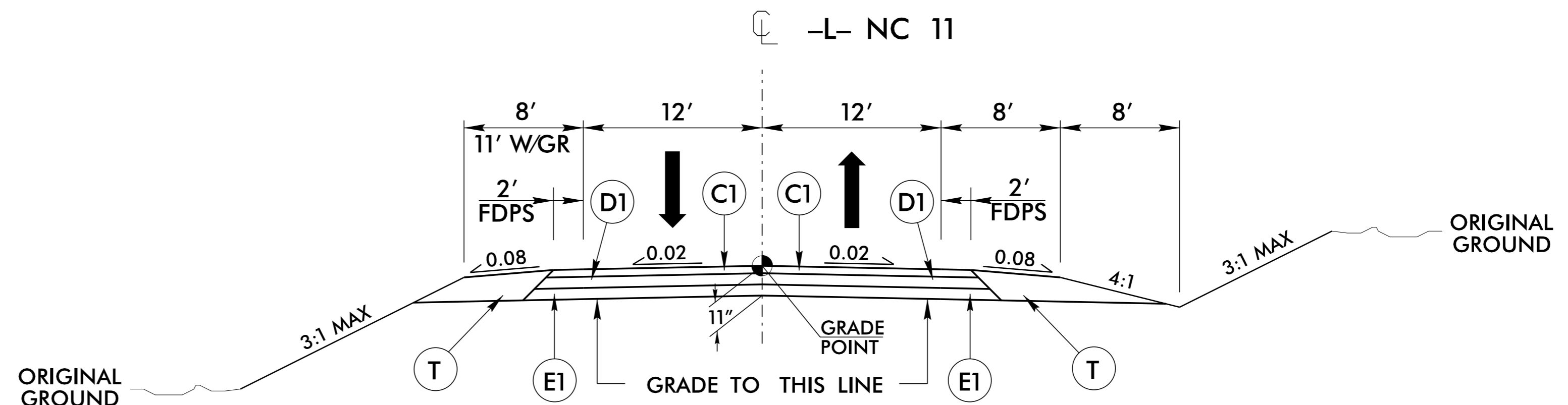

TYPICAL SECTION NO. 2

USE TYPICAL SECTION NO. 2
 -L- STA 16+50.00 TO 17+47.00 (BEGIN BRIDGE)
 -L- STA 19+07.00 (END BRIDGE) TO STA 20+30.00

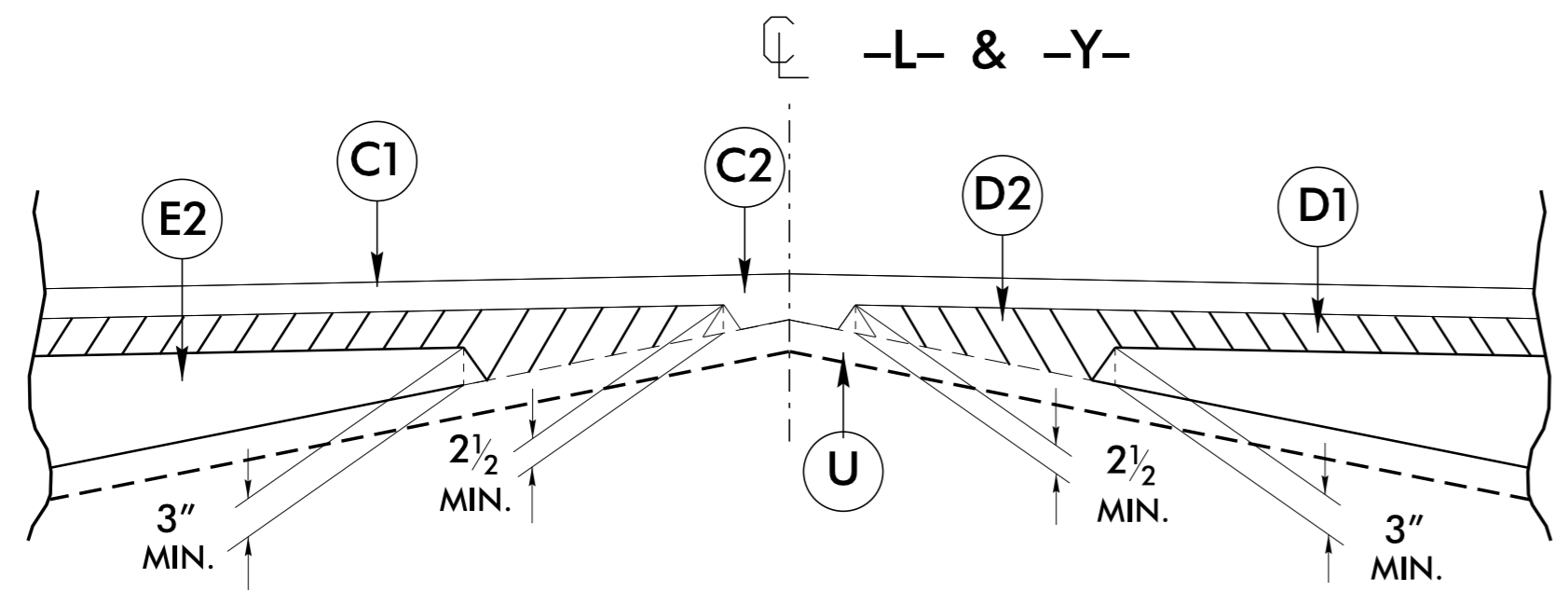

Detail Showing Method of Wedging

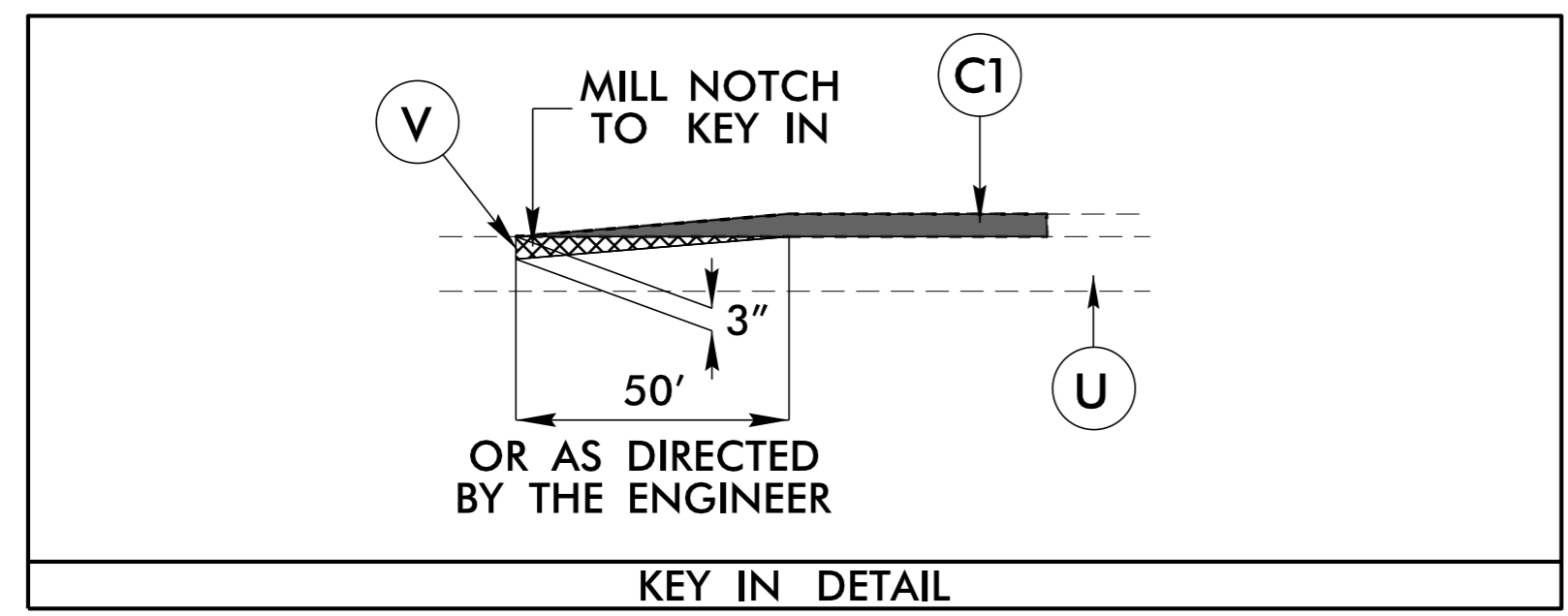

KEY IN DETAIL

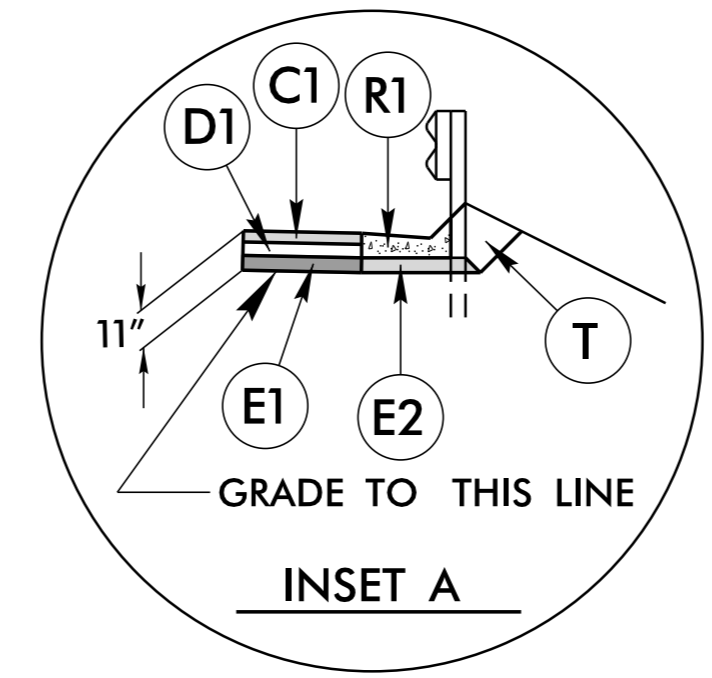

INSET A

USE INSET A WITH TYPICAL NO. 2
 -L- STA. 17+03.00 TO -L- STA. 17+37.56 LT
 -L- STA. 17+03.00 TO -L- STA. 17+28.36 RT
 -L- STA. 19+18.34 TO -L- STA. 19+33.00 RT

24-FEB-2021 11:22 AM BR0017_Rdy_4yp.dgn