

09_08/19

See Sig. 1B For Index of Sheets

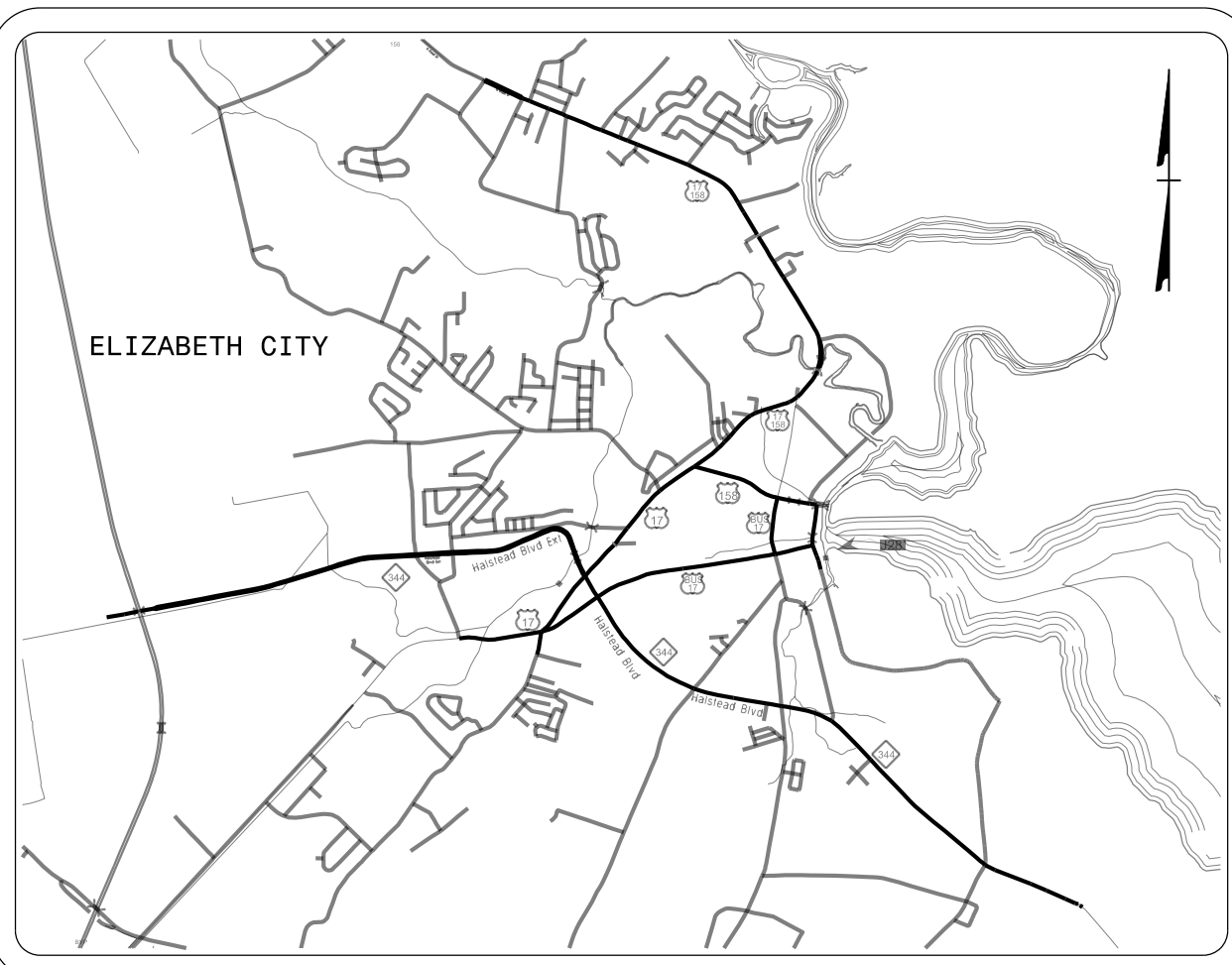

VICINITY MAP

NORTH CAROLINA
DEPARTMENT OF TRANSPORTATION

PLANS FOR PROPOSED IMPROVEMENTS
ELIZABETH CITY
COMPUTERIZED TRAFFIC SIGNAL SYSTEM

REPLACEMENT OF VARIOUS STANDALONE CLOSED-LOOP TRAFFIC SIGNAL SYSTEMS WITH A NEW COMPUTERIZED TRAFFIC SIGNAL SYSTEM.
RELATED WORK INCLUDES:
UPGRADING LOCAL INTERSECTION CONTROLLERS, CABINETS, AND SYSTEM DETECTORS WITH LIMITED SIGNAL WIRING AND SIGNAL HEAD UPGRADES WHEN NECESSARY; UPGRADE AND EXPANSION OF CCTV MONITORING NETWORK; INSTALLING CENTRAL EQUIPMENT AND CENTRAL SOFTWARE; AND INSTALLATION OF AN ETHERNET COMMUNICATIONS NETWORK COMPRISED OF FIBER-OPTIC CABLE WITH ALL RELATED EQUIPMENT.

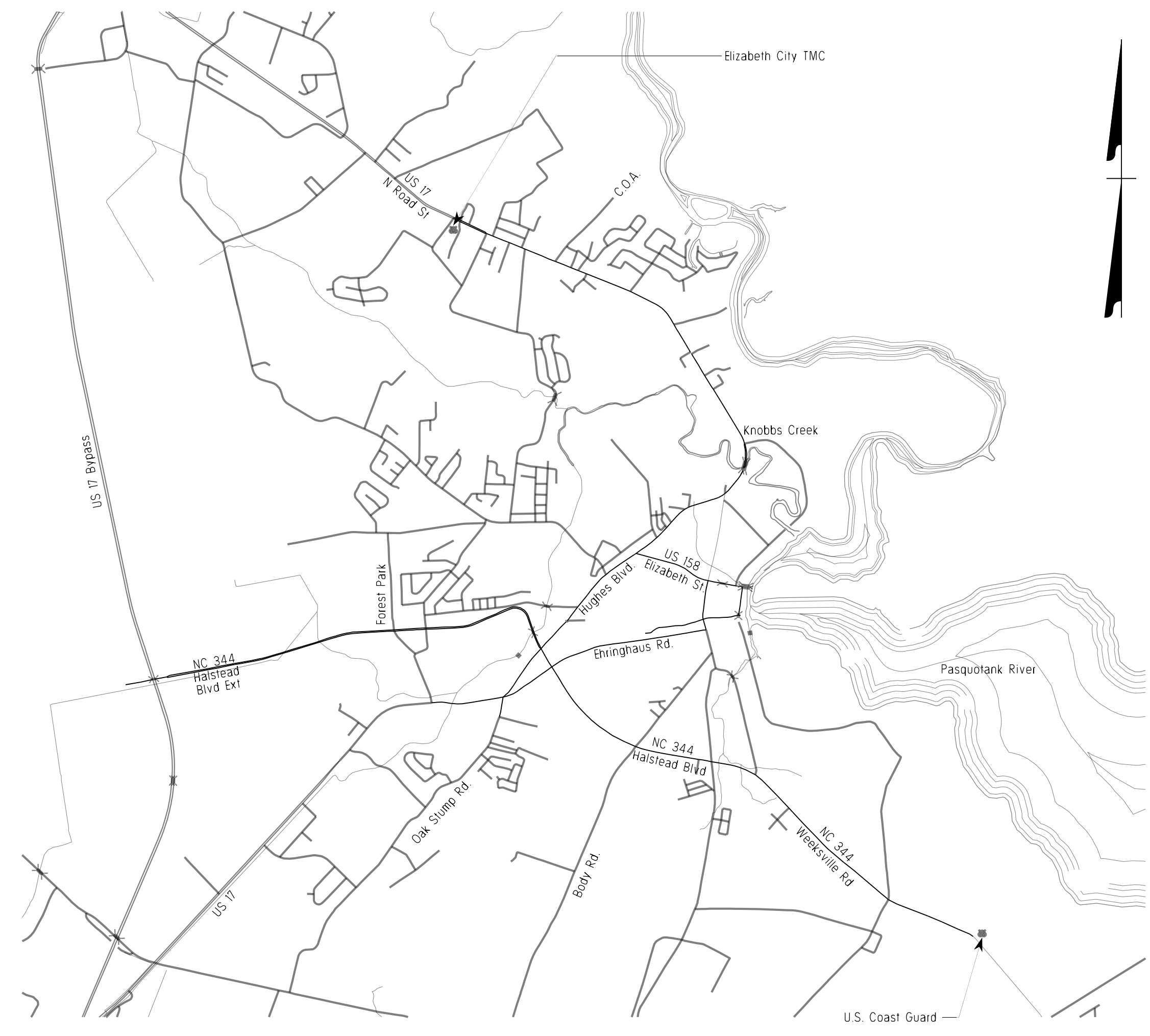

TIP PROJECT: U-5942

CONTRACT: C204154

*Volume III of III
Traffic Signal Designs*

STATE	STATE PROJECT REFERENCE NO.	SHEET NO.	TOTAL SHEETS
N.C.	U-5942	SIG. 1A	
STATE PROJ. NO.	F.A. PROJ. NO.	DESCRIPTION	
45861.1.1		PE	
45861.3.1	STBG-0111(25)	CONST	

01-FEB-2021 12:02 R:\U5942\Signals\Design\Signals\U-5942A_Signals_Title_Sheet.dgn DWMTre AT CAR-DWHHE

2018 STANDARD SPECIFICATION
LETTING DATE: APRIL 20, 2021
PROJECT LENGTH = 20 MILES

Prepared for the Offices of:

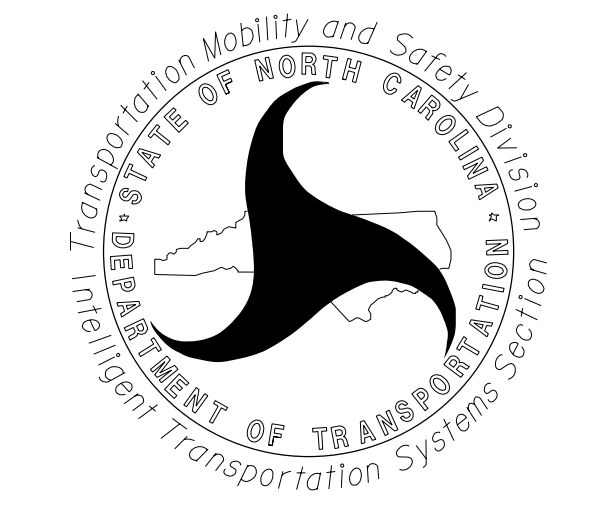

750 N. Greenfield Pkwy., Garner, NC 27529

NCDOT CONTACTS:
TRANSPORTATION MOBILITY & SAFETY DIVISION
INTELLIGENT TRANSPORTATION SYSTEMS SECTION
JASON GALLOWAY, PE - STATE SIGNALS ENGINEER
NEIL AVERY - SIGNAL COMMUNICATION PROJECT ENGINEER

Plans Prepared By:
DRMP
DRMP, Inc.
8000 Regency Parkway, Suite 175
Cary, NC 27518
NC License No. C-2213 (919) 650-1038

LM MOON, P.E. - SENIOR PROJECT ENGINEER
AJ DAVIS, P.E. - PROJECT DESIGN ENGINEER
RD LAWTON, EIT - PROJECT ENGINEER
DJ WHITE - PROJECT ENGINEER



DOCUMENT NOT CONSIDERED FINAL
UNLESS ALL SIGNATURES COMPLETED

ROADWAY STANDARD DRAWINGS

THE FOLLOWING ROADWAY STANDARDS AS APPEAR IN "ROADWAY STANDARD DRAWINGS" - CONTRACT SERVICES UNIT - N.C. DEPARTMENT OF TRANSPORTATION - RALEIGH, N.C., DATED JANUARY 2018 ARE APPLICABLE TO THIS PROJECT AND BY REFERENCE HEREBY ARE CONSIDERED A PART OF THESE PLANS:

STD. NO.	TITLE
848.01	CONCRETE SIDEWALK
848.05	CURB RAMP – PROPOSED CURB AND GUTTER
848.06	CURB RAMP – EXISTING CURB ANBD GUTTER
1101.01	WORK ZONE ADVANCED WARNING SIGNS
1101.02	TEMPORARY LANE CLOSURES
1101.03	TEMPORARY ROAD CLOSURES
1101.04	TEMPORARY SHOULDER CLOSURES
1101.11	TRAFFIC CONTROL DESIGN TABLES
1110.01	STATIONARY WORK ZONE SIGNS
1110.02	PORTABLE WORK ZONE SIGNS
1115.01	FLASHING ARROW BOARDS
1130.01	DRUM
1135.01	CONES
1145.01	BARRICADES – TYPE III
1150.01	FLAGGING DEVICES
1165.01	TRUCK MOUNTED ATTENUATOR – DELINEATION
1180.01	SKINNY-DRUM
1205.01	PAVEMENT MARKINGS – LINES TYPES AND OFFSETS
1205.02	PAVEMENT MARKINGS – DIVIDED AND UNDIVIDED ROADWAYS
1205.04	PAVEMENT MARKINGS – INTERSECTIONS
1205.05	PAVEMENT MARKINGS – TURN LANES
1205.07	PAVEMENT MARKINGS – PEDESTRIAN CROSSWALKS
1205.08	PAVEMENT MARKINGS – SYMBOLS AND WORD MESSAGES
1700.01	ELECTRICAL SERVICE OPTIONS
1700.02	ELECTRICAL SERVICE GROUNDING
1705.01	SIGNAL HEADS – VEHICULAR SIGNAL HEADS
1705.02	SIGNAL HEADS – PEDESTRIAN ASSEMBLIES
1705.03	SIGNAL HEADS – WIRE COLOR CONVENTIONS
1705.04	SIGNAL HEADS – PEDESTRIAN PUSHBUTTON LOCATION
1715.01	UNDERGROUND CONDUIT – TRENCHING
1716.01	JUNCTION BOXES
1721.01	GUY ASSEMBLIES
1725.01	INDUCTIVE DETECTION LOOPS
1730.01	FIBER-OPTIC CABLE – SPARE CABLE STORAGE
1743.02	PEDESTALS – NORMAL DUTY TYPE II
1743.04	PEDESTALS – FOUNDATIONS
1751.01	CONTROLLERS AND CABINETS – CABINET COMPONENT LAYOUT
1751.02	CONTROLLERS AND CABINETS – POWER, GROUND AND AUXILIARY

INDEX OF SHEETS

Volume I

ITS-1.00.....	TITLE SHEET – COMMUNICATIONS & CCTV FIELD INFRASTRUCTURE, BUILDING MODIFICATIONS AND SPECIAL DETAILS
ITS-1.01.....	INDEX OF SHEETS AND ROADWAY STANDARD DRAWINGS
ITS-2.00.....	CENTRAL BLOCK DIAGRAM
ITS-3.00 – ITS-3.01.....	SYSTEM DETECTORS AND CONTROL ZONE SCHEMATIC
ITS-4.00.....	CCTV CAMERA INSTALLATION, FOR WOOD SIGNAL POLES
ITS-4.01.....	CCTV CAMERA INSTALLATION, FOR METAL SIGNAL POLES
ITS-4.02.....	RISER DETAIL
ITS-4.03.....	FOUNDATION MODIFICATION DETAIL
ITS-4.04.....	GROUND MOUNTED ELECTRICAL SERVICE DETAIL
ITS-4.05.....	AERIAL FIBER-OPTIC CABLE STORAGE & SPLICE ENCLOSURES
ITS-4.06.....	BASE-MOUNTED CABINET FOUNDATION DETAILS
ITS-4.07.....	REVISED ROADWAY STANDARD DRAWINGS 1700D01 & 1720D01
ITS-4.08.....	REVISED ROADWAY STANDARD DRAWING 1743D01
ITS-4.09.....	TRAFFIC MANAGEMENT CENTER
ITS-4.10.....	COMMUNICATIONS RACK
CRP-001A – CRP-001D.....	SUMMARY OF WORK BY CABLE ROUTING PLANS
CRP-001E.....	CCTV INSTALLATION SUMMARY
CRP-002A.....	CABLE ROUTING PLANS KEY SHEET
CRP-002B.....	LEGEND/GENERAL NOTES/ABBREVIATIONS
CRP-002C.....	CONSTRUCTION NOTES
CRP-003 – CRP-069.....	CABLE ROUTING PLANS
TMP-1 – TMP-2.....	TRANSPORTATION MANAGEMENT PLANS

Volume II

FS-1.00.....	TITLE SHEET (FIBER-OPTIC SPLICING)
FS-1.01.....	INDEX OF SHEETS AND ROADWAY STANDARD DRAWINGS
FS-2.00.....	COMMS. CABLE SCHEMATIC
FS-2.01 – FS-2.04.....	FIBER-OPTIC RING SCHEMATICS
FS-3.00.....	FIBER-OPTIC CABLE USAGE SUMMARY
FS-3.01.....	FIBER-OPTIC SPLICE DETAILS KEY SHEET
FS-4.00 – FS-4.22.....	FIBER-OPTIC SPLICING DETAILS

Volume III

SIG. 1A.....	TITLE SHEET (TRAFFIC SIGNAL DESIGNS)
SIG. 1B.....	INDEX OF SHEETS AND ROADWAY STANDARD DRAWINGS
SIG. 1C.....	SIGNAL PLANS INDEX SHEET
SIG. 1D – 1I.....	SUMMARY OF WORK BY INTERSECTION
SIG. 1.0 – 44.3.....	TRAFFIC SIGNAL PLANS
SIG. M1 – M8.....	STANDARD DRAWING FOR METAL POLES

DOCUMENT NOT CONSIDERED FINAL UNLESS ALL SIGNATURES COMPLETED



	Elizabeth City Signal System Index of Sheets and Roadway Standard Drawings		
	Division 1 Pasquotank County Elizabeth City	PLAN DATE: April 2018	
PREPARED BY: R Lawton	REVIEWED BY:	REVISIONS	DATE
750 N. Greenfield Pkwy., Garner, NC 27529	DocuSigned by: Lisa M. Moon 3/27/2019	SEAL 022516 LISA M. MOON ENGINEER	DATE

CADD Filename:

NCDOT SIGNAL INVENTORY NUMBER	INTERSECTION	SIGNAL SHEET NUMBER	CABLE ROUTING SHEET NUMBER
01-0001	US 17 Bus./ Old NC 34 (Ehringhaus St.) at US 17 Bus./Old NC 34 (S. Road St.)	1	CRP-035
01-0002	Old NC 34 (Ehringhaus St.) at S. McMorrine St.	2	CRP-035
01-0004	US 158 (Elizabeth St.) at US 17 Bus. (N. Road St.)	3	CRP-038
01-0005	US 17 Bus. (Road St.) at Main St.	4	CRP-041
01-0006	US 17 Bus. (Road St.) at Church St.	5	CRP-041
01-0008	US 158 (Elizabeth St.) at Martin St.	6	CRP-038
01-0009	US 158 (Elizabeth St.) at Poindexter St.	7	CRP-037
01-0010	US 158 (Elizabeth St.) at Water St.	8	CRP-037
01-0011	NC 34 (Water St. at Main St.)	9	CRP-037
01-0012	Shepard St./Riverside Ave. at Southern Ave./Water St.	10	CRP-036
01-0013	US 17 (Hughes Blvd.) at SR 1309 (W. Main St.)/W. Main St. Ext.	11	CRP-011
01-0014	US 17 Bus. (Ehringhaus St.) at SR (Halstead Blvd.)	12	CRP-030
01-0015	US 17 (Hughes Blvd.) at SR 1152 (Halstead Blvd.)	13	CRP-008
01-0016	US 17 (Hughes Blvd.) at SR 1308 (W. Church St.)	14	CRP-010
01-0019	US 17 (S. Hughes Blvd.) at US 17 Bus. (W. Ehringhaus St.)/SR 1145 (Oak Stump Rd.)/Shopping C	15	CRP-005
01-0020	US 17-US 158 (N. Hughes Blvd.) at US 158-NC 168 (W. Elizabeth St.)	16	CRP-012
01-0022	US 17 Bus. (Ehringhaus St.) at Selden St.	17	CRP-033
01-0024	Old NC 34 (Water St.)/Sr 1164 (southern Ave.) at Old NC 34 (Ehringhaus St.)	18	CRP-036
01-0025	US 17-158 (Hughes Blvd.) at US 17 Bus. (Road St.)/SR 1327 (Griggs St.)	19	CRP-016
01-0034	US 17 Bus. (Ehringhaus St.) at McArthur St./Ent. To Southgate Mall	20	CRP-031
01-0092	US 17 (S. Hughes Blvd.) at SR 1306 (Forest Park Rd.)/Central Elem. School Ent.	21	CRP-003
01-0217	NC 334 (Halstead Blvd.) at SR 1101 (Peartree Rd.)	22	CRP-060
01-0219	NC 334 (Halstead Blvd.) at SR 1269 (Herrington Rd.)	23	CRP-062
01-0222	US 17 (S. Hughes Blvd.) at McArthur Dr.	24	CRP-009
01-0315	NC 344 (Halstead Blvd.) at Southgate Mall/Lowe's Shopping Ctr.	25	CRP-055
01-0336	NC 334 (Halstead Blvd.) at SR 1139 (Roanoke Ave./Body Rd.)	26	CRP-058
01-0374	US 17 Bus. (Ehringhaus St.) at Cardwell St./Harriot Dr.	27	CRP-031
01-0404	US 17-158 (N. Road St.) at SR1387 (Knobbs Creek Rd.)/Commercial Dr.	28	CRP-017
01-0407	NC 34 (Weeksville Rd.) at SR 1206 (Industrial Park Dr.)/Ent. To ECSU	29	CRP-064
01-0408	NC 334 (Weeksville Rd.) at SR 1164 (River Rd.)/SR 1169 (Pitts Chapel Rd.)	30	CRP-068
01-0442	US 17-158 (N. Road St.) at SR 1346 (Culpepper Ln.)/Fairway Terrace Dr.	31	CRP-023
01-0443	NC (Weeksville Rd.) at Moukawsher Dr./(Ent. To USCGS)	32	CRP-069
01-0461	US 17-158 at University Shopping Center/ Hall Ford	33	CRP-021
01-0465	SR 1145 (Oak Stump Rd.) at SR 1190 (Ranch Rd.)/Northeastern HS	34	CRP-006
01-0481	US 17-158 (N. Road St.) at Albemarle Hospital Exit/ECU School of Dental Medicine	35	CRP-019
01-0519	US 17 Bus. (Ehringhaus St.) at Griffin St./Post Office Ent.	36	CRP-032
01-0540	US 17-158 (North Road St.) at Medical Dr.	37	CRP-018
01-0629	US 17 Bus. (Ehringhaus St.) at Port Elizabeth Centre	38	CRP-029
01-0674	NC 344 (Halstead Blvd.) at Walker Ave.	39	CRP-056
01-0712	US 17-158 at SR 1383 (College of The Albemarle Ent.)	40	CRP-020
01-0747	NC 334 (Halstead Blvd.) at Wal-mart Ent./Tanglewood Parkway South	41	CRP-044
01-0749	NC 334 (Halstead Blvd.) at SR 1307 (Forest Park Rd.)	42	CRP-050
01-0750	NC 344 at Edgewood Dr./Weeksville Crossing Ent.	43	CRP-064
01-0755	NC 344 (Halstead Exd.) at Mt. Everest Way/Mt. Everest Dr.	44	CRP-045

DOCUMENT NOT CONSIDERED FINAL UNLESS ALL SIGNATURES COMPLETED



	Elizabeth City Signal System Signal Plans Index Sheet		
	Division 1 Pasquotank County Elizabeth City	PLAN DATE: April 2018	
750 N. Greenfield Pkwy., Garner, NC 27529 N.T.S.	PREPARED BY: R Lawton	REVIEWED BY:	DocuSigned by: 8/23/2018 DATE:

CADD Filename:

SUMMARY OF WORK BY INTERSECTION

Reference Information					*Conduit and Riser Work																						
	NCDOT Signal Inv. No.	Intersection Name	Cable Routing Sheet Number	Signal Design Sheet Number	In / near historically significant area (see box note at bottom of page)	Drill / Core Drill for 1" for New Power Service or New CAT6	Drill / Core Drill for 2" for FO	Reuse Ex. 2" Dedicated Metal Riser for Comm (Heat Shrink Tubing Kit)	Reuse Ex. 2" Dedicated Conduit Entrance for UG Comm	Use 2" Spare Conduit for UG Comm	New 2" Riser (HST) for Comm	New 1" Riser (WH) for CAT6	New UG Conduit for Comm Entrance	New Cabinet Entrance in New Foundation for Comm	New 1/2" Risers (WH) for Sig- Pedestrian Push Buttons	New 1" Riser (WH) for Ped Heads	New 1" Risers (WH) for Sig- New Electrical Service	New 2" Risers (WH) for Sig- New Foundation Location	New 2" Risers (WH) for System Detector	New 2" Risers (WH) for Sig (replace existing)	Underground Conduit (1, 1")	Underground Conduit (1, 2")	Underground Conduit (2, 2")	Underground Conduit (3, 2")	Directional Drill Conduit (1, 2")	Directional Drill Conduit (2, 2")	
1	01-0001	US 17 Bus./ Old NC 34 (Ehringhaus St.) at US 17 Bus./Old NC 34 (S. Road St.)	CRP-035	1.0		1			1		1	1															
2	01-0002	Old NC 34 (Ehringhaus St.) at S. McMorrine St.	CRP-035	2.0	Y					1				1	5	5		2			30	140	70				
3	01-0004	US 158 (Elizabeth St.) at US 17 Bus. (N. Road St.)	CRP-038	3.0	Y				1																		
4	01-0005	US 17 Bus. (Road St.) at Main St.	CRP-041	4.0	Y	1	1			1	1																
5	01-0006	US 17 Bus. (Road St.) at Church St.	CRP-041	5.0	Y		1			1																	
6	01-0008	US 158 (Elizabeth St.) at Martin St.	CRP-038	6.0	Y				1																		
7	01-0009	US 158 (Elizabeth St.) at Poindexter St.	CRP-037	7.0	Y				1																		
8	01-0010	US 158 (Elizabeth St.) at Water St.	CRP-037	8.0	Y	1			1	1			1														
9	01-0011	NC 34 (Water St. at Main St.)	CRP-037	9.0	Y					1																	
10	01-0012	Shepard St./Riverside Ave. at Southern Ave./Water St.	CRP-036	10.0							1		1	1			1	2	1		20	20		20			
11	01-0013	US 17 (Hughes Blvd.) at SR 1309 (W. Main St.)/W. Main St. Ext.	CRP-011	11.0	Y	1		1				1								1							
12	01-0014	US 17 Bus. (Ehringhaus St.) at SR (Halstead Blvd.)	CRP-030	12.0			1						1										70				
13	01-0015	US 17 (Hughes Blvd.) at SR 1152 (Halstead Blvd.)	CRP-008	13.0				1	1																		
14	01-0016	US 17 (Hughes Blvd.) at SR 1308 (W. Church St.)	CRP-010	14.0					1																		
15	01-0019	US 17 (S. Hughes Blvd.) at US 17 Bus. (W. Ehringhaus St.)/SR 1145 (Oak Stump Rd.)/Shopping	CRP-005	15.0		1	1					1	1							1							
16	01-0020	US 17-US 158 (N. Hughes Blvd.) at US 158-NC 168 (W. Elizabeth St.)	CRP-012	16.0	Y	1						1		1			1	2									
17	01-0022	US 17 Bus. (Ehringhaus St.) at Selden St.	CRP-033	17.0							1	1		1			1	2				120	70				
18	01-0024	Old NC 34 (Water St.)/Sr 1164 (southern Ave.) at Old NC 34 (Ehringhaus St.)	CRP-036	18.0								1	1	1	1		1	4									
19	01-0025	US 17-158 (Hughes Blvd.) at US 17 Bus. (Road St.)/SR 1327 (Griggs St.)	CRP-016	19.0							1	1		1			1	2									
20	01-0034	US 17 Bus. (Ehringhaus St.) at McArthur St./Ent. To Southgate Mall	CRP-031	20.0				1															70				
21	01-0092	US 17 (S. Hughes Blvd.) at SR 1306 (Forest Park Rd.)/Central Elem. School Ent.	CRP-003	21.0																1		20					
22	01-0217	NC 334 (Halstead Blvd.) at SR 1101 (Peartree Rd.)	CRP-060	22.0		1				1		1															

This area has been determined to contain properties with documented historic significance. If it is necessary to deviate from these plans in this area, alert the Engineer to contact Historic Architecture Group of the North Carolina Department of Transportation for an effects determination before proceeding.

- Work shown on this sheet is for the upgrade of the traffic signals, including installation of new controllers and cabinets, new or modified foundations, electrical service and miscellaneous signal related items. additional information can be found in the signal plans in this Volume. Work to be done for fiber-optic cable routing and interconnection is shown on the cable layout plans and on the sheets entitled "Summary of Work by Cable Layout Plans" in Volume I of III.
- The items listed above are for informational purposes only and represent work that is necessary to complete the project and are not necessarily pay items. See Summary of Quantities and the Project Special Provisions for defined Pay Items for this contract.



Prepared for the Offices of:

 Elizabeth City Signal System
 Summary of Work by
 Intersection (sheet 2 of 6)

Division 1 Pasquotank County Elizabeth City
 PLAN DATE: April 2018 REVIEWED BY: RD Lawton
 PREPARED BY: DJ White REVIEWED BY: LW Moon

REVISIONS: _____ INIT. DATE: _____

N. T. S.

DocuSigned by:

 Lisa M. Moon 9/24/2018
 CADD Filename: _____

DOCUMENT NOT CONSIDERED FINAL UNLESS ALL SIGNATURES COMPLETED

SUMMARY OF WORK BY INTERSECTION

Reference Information					Signal Items																														
NCDOT Signal Inv. No.	Intersection Name	Cable Routing Sheet Number	Signal Design Sheet Number	In / near historically significant area (see box note at bottom of page)	16-inch Countdown Pedestrian Signal Head	12-inch 3-Section Signal Head	12-inch 4-Section Signal Head	12-inch 5-Section Signal Head	Signal Cable	Messenger Cable (3/8")	Sign for Signals	Inductive Loop Sawcut	Loop Lead-In Cable	Span Transfer	Wood Pole for Signals	50' Wood Pole for Signals and CCTV	Metal Strain Pole	Soil Test	Drilled Pier Foundation	Standard Down Guy Assembly	Sidewalk Guy Assembly	Type I Post with Foundation	Type II Pedestal with Foundation	Junction Box (Standard Size)	Thermoplastic Double Yellow Lane Line (4", 90 MILS)	Thermoplastic Lane Line (4", 90 MILS)	Thermoplastic White Stop Bar (24", 90 MILS)	Thermoplastic White Crosswalk Line (24", 90 MILS)	Thermoplastic Symbols (90 MILS)	Remove Symbol & Characters	Remove Line 4"	Remove Line 24"			
1	01-0001	US 17 Bus./ Old NC 34 (Ehringhaus St.) at US 17 Bus./Old NC 34 (S. Road St.)	CRP-035	1.0		4	2		620			360	2240	4		1					4				1										
2	01-0002	Old NC 34 (Ehringhaus St.) at S. McMorrine St.	CRP-035	2.0	Y	6			1850			550	2640											1	4			80	210						
3	01-0004	US 158 (Elizabeth St.) at US 17 Bus. (N. Road St.)	CRP-038	3.0	Y																														
4	01-0005	US 17 Bus. (Road St.) at Main St.	CRP-041	4.0	Y	8	6	2	2	2890	250		2940																						
5	01-0006	US 17 Bus. (Road St.) at Church St.	CRP-041	5.0	Y		4		4	410	550	700	310		1						5	2			2	110	60	110					120		
6	01-0008	US 158 (Elizabeth St.) at Martin St.	CRP-038	6.0	Y																														
7	01-0009	US 158 (Elizabeth St.) at Poindexter St.	CRP-037	7.0	Y																														
8	01-0010	US 158 (Elizabeth St.) at Water St.	CRP-037	8.0	Y																														
9	01-0011	NC 34 (Water St. at Main St.)	CRP-037	9.0	Y	8	2	1		310		1160	680											4											
10	01-0012	Shepard St./Riverside Ave. at Southern Ave./Water St.	CRP-036	10.0						530		110	2140											1											
11	01-0013	US 17 (Hughes Blvd.) at SR 1309 (W. Main St.)/W. Main St. Ext.	CRP-011	11.0	Y		10	2		1390	2		1670	4		1					2														
12	01-0014	US 17 Bus. (Ehringhaus St.) at SR (Halstead Blvd.)	CRP-030	12.0		8				1220			1200	1		1					2			8	4		150	640					160		
13	01-0015	US 17 (Hughes Blvd.) at SR 1152 (Halstead Blvd.)	CRP-008	13.0			12		1				880																						
14	01-0016	US 17 (Hughes Blvd.) at SR 1308 (W. Church St.)	CRP-010	14.0			8	2		1270		60	760	8																					
15	01-0019	US 17 (S. Hughes Blvd.) at US 17 Bus. (W. Ehringhaus St.)/SR 1145 (Oak Stump Rd.)/Shopping	CRP-005	15.0			1			150				2		1					4														
16	01-0020	US 17-US 158 (N. Hughes Blvd.) at US 158-NC 168 (W. Elizabeth St.)	CRP-012	16.0	Y		6	1		570			3190	4		1					2														
17	01-0022	US 17 Bus. (Ehringhaus St.) at Selden St.	CRP-033	17.0		6	8	2		2010	400	590	2400		1	1					6			6	4		80	130			20	60			
18	01-0024	Old NC 34 (Water St.)/Sr 1164 (southern Ave.) at Old NC 34 (Ehringhaus St.)	CRP-036	18.0		4	3	1		640			820	2										1											
19	01-0025	US 17-158 (Hughes Blvd.) at US 17 Bus. (Road St.)/SR 1327 (Griggs St.)	CRP-016	19.0			10	3		1280	540		3850		1	1					8														
20	01-0034	US 17 Bus. (Ehringhaus St.) at McArthur St./Ent. To Southgate Mall	CRP-031	20.0		6				1010			1940											6		40	180			20	60				
21	01-0092	US 17 (S. Hughes Blvd.) at SR 1306 (Forest Park Rd.)/Central Elem. School Ent.	CRP-003	21.0								550	810	2	1						2					90				30	90				
22	01-0217	NC 334 (Halstead Blvd.) at SR 1101 (Peartree Rd.)	CRP-060	22.0								170	860	8		1					2			2											

This area has been determined to contain properties with documented historic significance. If it is necessary to deviate from these plans in this area, alert the Engineer to contact Historic Architecture Group of the North Carolina Department of Transportation for an effects determination before proceeding.

- Work shown on this sheet is for the upgrade of the traffic signals, including installation of new controllers and cabinets, new or modified foundations, electrical service and miscellaneous signal related items. additional information can be found in the signal plans in this Volume. Work to be done for fiber-optic cable routing and interconnection is shown on the cable layout plans and on the sheets entitles "Summary of Work by Cable Layout Plans" in Volume I of III.
- The items listed above are for informational purposes only and represent work that is necessary to complete the project and are not necessarily pay items. See Summary of Quantities and the Project Special Provisions for defined Pay Items for this contract.



Prepared for the Offices of:

Elizabeth City Signal System
Summary of Work by
Intersection (sheet 3 of 6)

Division 1 Pasquotank County Elizabeth City

PLAN DATE: April 2018 REVIEWED BY: RD Lawton

PREPARED BY: DJ White REVIEWED BY: LW Moon

REVISIONS: _____ INIT. DATE

N. T. S.

DocuSigned by:
Lisa M. Moon 3/27/2019
50c5880d300421 DATE

CADD Filename:

DOCUMENT NOT CONSIDERED FINAL UNLESS ALL SIGNATURES COMPLETED

SUMMARY OF WORK BY INTERSECTION

Reference Information					Controller, Cabinet & Foundation Work													Power Service						
NCDOT Signal Inv. No.	Intersection Name	Cable Routing Sheet Number	Signal Design Sheet Number	In / near historically significant area (see box note at bottom of page)	New 2070 Controller	New Type 170 Cabinet	No. of New Detector Cards	Adjacent to Existing	Relocated to (quadrant)	Comment	Modify Foundation	Remove Existing Foundation	Rotate Front of Cabinet clockwise (degrees)	Base Extender	Ex. Height - Ground to Bottom (inches)	Relocate existing opticom equipment	Relocate existing sensys equipment	Relocate existing bridge preemption equipment	Replace concrete (SF)	Replace Brick (SF)	Modify Existing Power Service - Install New Service Wires in Existing Conduit	Modify Existing Power Service - Install New Service Wires in New Conduit	Modify Existing Power Service - New 50 amp Breaker	Install New Electrical Service
23	01-0219	NC 334 (Halstead Blvd.) at SR 1269 (Herrington Rd.)	CRP-062	23.0	1	1	8							0	1	1							1	
24	01-0222	US 17 (S. Hughes Blvd.) at McArthur Dr.	CRP-009	24.0	1	1	5							0	1	1								
25	01-0315	NC 344 (Halstead Blvd.) at Southgate Mall/Lowe's Shopping Ctr.	CRP-055	25.0	1	1	6							0	1									
26	01-0336	NC 334 (Halstead Blvd.) at SR 1139 (Roanoke Ave./Body Rd.)	CRP-058	26.0	1	1	8							0	1	1								
27	01-0374	US 17 Bus. (Ehringhaus St.) at Cardwell St./Hariot Dr.	CRP-031	27.0	1	1	7							0	1									
28	01-0404	US 17-158 (N. Road St.) at SR1387 (Knobbs Creek Rd.)/Commercial Dr.	CRP-017	28.0	1	1	4							0	1	1	1							
29	01-0407	NC 34 (Weeksville Rd.) at SR 1206 (Industrial Park Dr.)/Ent. To ECSU	CRP-064	29.0	1	1	6	1	NW	Relocate across NC 344	1	0	1										1	
30	01-0408	NC 334 (Weeksville Rd.) at SR 1164 (River Rd.)/SR 1169 (Pitts Chapel Rd.)	CRP-068	30.0	1	1	8			Remove abandoned Cabinet Foundation	1	0	1											
31	01-0442	US 17-158 (N. Road St.) at SR 1346 (Culpepper Ln.)/Fairway Terrace Dr.	CRP-023	31.0	1	1	6							0	1									
32	01-0443	NC (Weeksville Rd.) at Moukawsher Dr. (Ent. To USCGS)	CRP-069	32.0	1	1	5							0	1						1		1	
33	01-0461	US 17-158 at University Shopping Center/ Hall Ford	CRP-021	33.0	1	1	6				1	0	1										1	
34	01-0465	SR 1145 (Oak Stump Rd.) at SR 1190 (Ranch Rd.)/Northeastern HS	CRP-006	34.0	1	1	4				1	0	1								1		1	
35	01-0481	US 17-158 (N. Road St.) at Albemarle Hospital Exit/ECU School of Dental Medicine	CRP-019	35.0	1	1	6							0	1	1								
36	01-0519	US 17 Bus. (Ehringhaus St.) at Griffin St./Post Office Ent.	CRP-032	36.0	1	1	10	1		just behind existing along Post Office drive	1	-20	1										1	
37	01-0540	US 17-158 (North Road St.) at Medical Dr.	CRP-018	37.0	1	1	8							0	1	1								
38	01-0629	US 17 Bus. (Ehringhaus St.) at Port Elizabeth Centre	CRP-029	38.0	1	1	8			Add technician pad to back side of cabinet foundation	1	0	1										1	
39	01-0674	NC 344 (Halstead Blvd.) at Walker Ave.	CRP-056	39.0	1	1	5							0	1									
40	01-0712	US 17-158 at SR 1383 (College of The Albemarle Ent.)	CRP-020	40.0	1	1	5							0	1									
41	01-0747	NC 334 (Halstead Blvd.) at Wal-mart Ent./Tanglewood Parkway South	CRP-044	41.0	1	1	8							0	1									
42	01-0749	NC 334 (Halstead Blvd.) at SR 1307 (Forest Park Rd.)	CRP-050	42.0	1	1	6							0	1									
43	01-0750	NC 344 at Edgewood Dr./Weeksville Crossing Ent.	CRP-064	43.0	1	1	6							0	1									
44	01-0755	NC 344 (Halstead Exd.) at Mt. Everest Way/Mt. Everest Dr.	CRP-045	44.0	1	1	7							0	1	1								
Total					44	44	282	7	1		6	7		44	22	5	3	90	8	4	1	3	10	

This area has been determined to contain properties with documented historic significance. If it is necessary to deviate from these plans in this area, alert the Engineer to contact Historic Architecture Group of the North Carolina Department of Transportation for an effects determination before proceeding.

- Work shown on this sheet is for the upgrade of the traffic signals, including installation of new controllers and cabinets, new or modified foundations, electrical service and miscellaneous signal related items. additional information can be found in the signal plans in this Volume. Work to be done for fiber-optic cable routing and interconnection is shown on the cable layout plans and on the sheets entitles "Summary of Work by Cable Layout Plans" in Volume I of III.
- The items listed above are for informational purposes only and represent work that is necessary to complete the project and are not necessarily pay items. See Summary of Quantities and the Project Special Provisions for defined Pay Items for this contract.

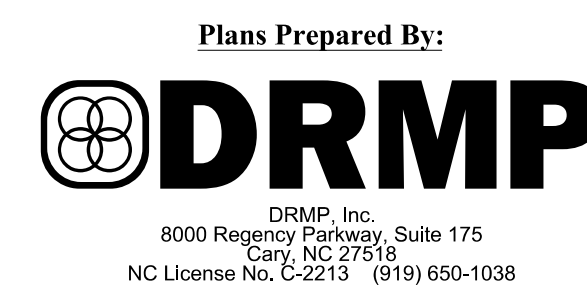

DOCUMENT NOT CONSIDERED FINAL UNLESS ALL SIGNATURES COMPLETED

Prepared for the Offices of:		Elizabeth City Signal System Summary of Work by Intersection (sheet 4 of 6)	
Division 1 Pasquotank County Elizabeth City			
PLAN DATE: April 2018	REVIEWED BY: RD Lawton		
PREPARED BY: DJ White	REVIEWED BY: LW Moon		
REVISIONS	INIT.	DATE	
N. T. S.			

DocuSigned by: Lisa M. Moon 1/16/2019

CADD Filename:

SUMMARY OF WORK BY INTERSECTION

Reference Information						*Conduit and Riser Work																				
	NCDOT Signal Inv. No.	Intersection Name	Cable Routing Sheet Number	Signal Design Sheet Number	In / near historically significant area (see box note at bottom of page)	Drill / Core Drill for 1" for New Power Service or New CAT6	Drill / Core Drill for 2" for FO	Reuse Ex. 2" Dedicated Metal Riser for Comm (Heat Shrink Tubing Kit)	Reuse Ex. 2" Dedicated Conduit Entrance for UG Comm	Use 2" Spare Conduit for UG Comm	New 2" Riser (HST) for Comm	New 1" Riser (WH) for CAT6	New UG Conduit for Comm Entrance	New Cabinet Entrance in New Foundation for Comm	New 1/2" Risers (WH) for Sig- Pedestrian Push Buttons	New 1" Riser (WH) for Ped Heads	New 1" Risers (WH) for Sig- New Electrical Service	New 2" Risers (WH) for Sig- New Foundation Location	New 2" Risers (WH) for System Detector	New 2" Risers (WH) for Sig (replace existing)	Underground Conduit (1, 1')	Underground Conduit (1, 2')	Underground Conduit (2, 2')	Underground Conduit (3, 2')	Directional Drill Conduit (1, 2')	Directional Drill Conduit (2, 2')
23	01-0219	NC 334 (Halstead Blvd.) at SR 1269 (Herrington Rd.)	CRP-062	23.0		1			1		1															
24	01-0222	US 17 (S. Hughes Blvd.) at McArthur Dr.	CRP-009	24.0				1		1																
25	01-0315	NC 344 (Halstead Blvd.) at Southgate Mall/Lowe's Shopping Ctr.	CRP-055	25.0				1	1																	
26	01-0336	NC 334 (Halstead Blvd.) at SR 1139 (Roanoke Ave./Body Rd.)	CRP-058	26.0					1	1	1															
27	01-0374	US 17 Bus. (Ehringhaus St.) at Cardwell St./Hariot Dr.	CRP-031	27.0				1							4	4										
28	01-0404	US 17-158 (N. Road St.) at SR1387 (Knobbs Creek Rd.)/Commercial Dr.	CRP-017	28.0					1																	
29	01-0407	NC 34 (Weeksville Rd.) at SR 1206 (Industrial Park Dr.)/Ent. To ECSU	CRP-064	29.0								1	1									180			220	
30	01-0408	NC 334 (Weeksville Rd.) at SR 1164 (River Rd.)/SR 1169 (Pitts Chapel Rd.)	CRP-068	30.0		1			1		1															
31	01-0442	US 17-158 (N. Road St.) at SR 1346 (Culpepper Ln.)/Fairway Terrace Dr.	CRP-023	31.0		1			1																	
32	01-0443	NC (Weeksville Rd.) at Moukawsher Dr. (Ent. To USCGS)	CRP-069	32.0					1	1								2								
33	01-0461	US 17-158 at University Shopping Center/ Hall Ford	CRP-021	33.0				1																		
34	01-0465	SR 1145 (Oak Stump Rd.) at SR 1190 (Ranch Rd.)/Northeastern HS	CRP-006	34.0			1				1															
35	01-0481	US 17-158 (N. Road St.) at Albemarle Hospital Exit/ECU School of Dental Medicine	CRP-019	35.0				1																		
36	01-0519	US 17 Bus. (Ehringhaus St.) at Griffin St./Post Office Ent.	CRP-032	36.0		1					1	1	1	2	2	1	3				40		105	20		
37	01-0540	US 17-158 (North Road St.) at Medical Dr.	CRP-018	37.0			1					1										10				
38	01-0629	US 17 Bus. (Ehringhaus St.) at Port Elizabeth Centre	CRP-029	38.0						1							1		1	1		690				
39	01-0674	NC 344 (Halstead Blvd.) at Walker Ave.	CRP-056	39.0				1	1	1																
40	01-0712	US 17-158 at SR 1383 (College of The Albemarle Ent.)	CRP-020	40.0		1		1			1								1			580			80	
41	01-0747	NC 334 (Halstead Blvd.) at Wal-mart Ent./Tanglewood Parkway South	CRP-044	41.0					1																	
42	01-0749	NC 334 (Halstead Blvd.) at SR 1307 (Forest Park Rd.)	CRP-050	42.0					1																	
43	01-0750	NC 344 at Edgewood Dr./Weeksville Crossing Ent.	CRP-064	43.0			1			1																
44	01-0755	NC 344 (Halstead Exd.) at Mt. Everest Way/Mt. Everest Dr.	CRP-045	44.0					1																	
Total						12	7	10	8	14	13	14	9	8	12	11	7	17	4	5	90	1680	495	40	80	220

This area has been determined to contain properties with documented historic significance. If it is necessary to deviate from these plans in this area, alert the Engineer to contact Historic Architecture Group of the North Carolina Department of Transportation for an effects determination before proceeding.

- Work shown on this sheet is for the upgrade of the traffic signals, including installation of new controllers and cabinets, new or modified foundations, electrical service and miscellaneous signal related items. additional information can be found in the signal plans in this Volume. Work to be done for fiber-optic cable routing and interconnection is shown on the cable layout plans and on the sheets entitles "Summary of Work by Cable Layout Plans" in Volume I of III.
- The items listed above are for informational purposes only and represent work that is necessary to complete the project and are not necessarily pay items. See Summary of Quantities and the Project Special Provisions for defined Pay Items for this contract.

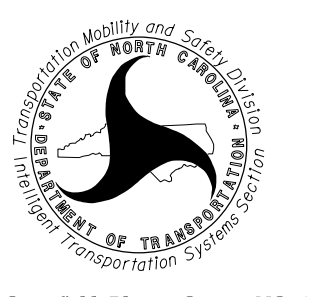

DOCUMENT NOT CONSIDERED FINAL UNLESS ALL SIGNATURES COMPLETED

Prepared for the Offices of: 		Elizabeth City Signal System Summary of Work by Intersection (sheet 5 of 6)		SEAL LISA M. MOON ENGINEER
Division 1 Pasquotank County Elizabeth City		PLANNED BY: April 2018 REVIEWED BY: RD Lawton		DocuSigned by: <i>Lisa Moon</i> 1/16/2019
PREPARED BY: DJ White REVIEWED BY: LW Moon		REVISIONS		
N. T. S.				DATE

CADD Filename:

SUMMARY OF WORK BY INTERSECTION

Reference Information					Signal Items																														
NCDOT Signal Inv. No.	Intersection Name	Cable Routing Sheet Number	Signal Design Sheet Number	In / near historically significant area (see box note at bottom of page)	16-inch Countdown Pedestrian Signal Head	12-inch 3-Section Signal Head	12-inch 4-Section Signal Head	12-inch 5-Section Signal Head	Signal Cable	Messenger Cable (3/8")	Sign for Signals	Inductive Loop Sawcut	Loop Lead-In Cable	Span Transfer	Wood Pole for Signals	50' Wood Pole for Signals and CCTV	Metal Strain Pole	Soil Test	Drilled Pier Foundation	Standard Down Guy Assembly	Sidewalk Guy Assembly	Type I Post with Foundation	Type II Pedestal with Foundation	Junction Box (Standard Size)	Thermoplastic Double Yellow Lane Line (4", 90 MILS)	Thermoplastic Lane Line (4", 90 MILS)	Thermoplastic White Stop Bar (24", 90 MILS)	Thermoplastic White Crosswalk Line (24", 90 MILS)	Thermoplastic Symbols (90 MILS)	Remove Symbol & Characters	Remove Line 4"	Remove Line 24"			
23	01-0219 NC 334 (Halstead Blvd.) at SR 1269 (Herrington Rd.)	CRP-062	23.0											2	1					2															
24	01-0222 US 17 (S. Hughes Blvd.) at McArthur Dr.	CRP-009	24.0			5	1	1	440					2																					
25	01-0315 NC 344 (Halstead Blvd.) at Southgate Mall/Lowe's Shopping Ctr.	CRP-055	25.0									190	70																						
26	01-0336 NC 334 (Halstead Blvd.) at SR 1139 (Roanoke Ave./Body Rd.)	CRP-058	26.0											5	1					2															
27	01-0374 US 17 Bus. (Ehringhaus St.) at Cardwell St./Harriot Dr.	CRP-031	27.0		6	2	1		1270				1670	2													30	90					20		
28	01-0404 US 17-158 (N. Road St.) at SR1387 (Knobbs Creek Rd.)/Commercial Dr.	CRP-017	28.0									220	180																						
29	01-0407 NC 34 (Weeksville Rd.) at SR 1206 (Industrial Park Dr.)/Ent. To ECSU	CRP-064	29.0			9	1		1200	500			3600				2"	2	23.3				5												
30	01-0408 NC 334 (Weeksville Rd.) at SR 1164 (River Rd.)/SR 1169 (Pitts Chapel Rd.)	CRP-068	30.0									150	220	2	1																				
31	01-0442 US 17-158 (N. Road St.) at SR 1346 (Culpepper Ln.)/Fairway Terrace Dr.	CRP-023	31.0									180																							
32	01-0443 NC (Weeksville Rd.) at Moukawsher Dr. (Ent. To USCGS)	CRP-069	32.0										2930	5	3					5															
33	01-0461 US 17-158 at University Shopping Center/ Hall Ford	CRP-021	33.0																								80					70	80		
34	01-0465 SR 1145 (Oak Stump Rd.) at SR 1190 (Ranch Rd.)/Northeastern HS	CRP-006	34.0											1																					
35	01-0481 US 17-158 (N. Road St.) at Albemarle Hospital Exit/ECU School of Dental Medicine	CRP-019	35.0											1																					
36	01-0519 US 17 Bus. (Ehringhaus St.) at Griffin St./Post Office Ent.	CRP-032	36.0		6	7	3		1880	330			3090		1	1				2	1	2		1	100	90	90	320			20				
37	01-0540 US 17-158 (North Road St.) at Medical Dr.	CRP-018	37.0											2													90								
38	01-0629 US 17 Bus. (Ehringhaus St.) at Port Elizabeth Centre	CRP-029	38.0			1	1		670				3460	2	1					2				6											
39	01-0674 NC 344 (Halstead Blvd.) at Walker Ave.	CRP-056	39.0											2																					
40	01-0712 US 17-158 at SR 1383 (College of The Albemarle Ent.)	CRP-020	40.0									390	2280	2	1					2			5												
41	01-0747 NC 334 (Halstead Blvd.) at Wal-mart Ent./Tanglewood Parkway South	CRP-044	41.0								1																								
42	01-0749 NC 334 (Halstead Blvd.) at SR 1307 (Forest Park Rd.)	CRP-050	42.0				2																												
43	01-0750 NC 344 at Edgewood Dr./Weeksville Crossing Ent.	CRP-064	43.0			2			300					6																					
44	01-0755 NC 344 (Halstead Exd.) at Mt. Everest Way/Mt. Everest Dr.	CRP-045	44.0																																
Total					58	110	26	9	21910	2570	3	5380	46830	69	9	13	2	2	23.3	54	3	4	22	39	210	90	790	1680	4	7	160	590			

*Black Powder Coating

This area has been determined to contain properties with documented historic significance. If it is necessary to deviate from these plans in this area, alert the Engineer to contact Historic Architecture Group of the North Carolina Department of Transportation for an effects determination before proceeding.

- Work shown on this sheet is for the upgrade of the traffic signals, including installation of new controllers and cabinets, new or modified foundations, electrical service and miscellaneous signal related items. additional information can be found in the signal plans in this Volume. Work to be done for fiber-optic cable routing and interconnection is shown on the cable layout plans and on the sheets entitles "Summary of Work by Cable Layout Plans" in Volume I of III.
- The items listed above are for informational purposes only and represent work that is necessary to complete the project and are not necessarily pay items. See Summary of Quantities and the Project Special Provisions for defined Pay Items for this contract.



DOCUMENT NOT CONSIDERED FINAL UNLESS ALL SIGNATURES COMPLETED

Prepared for the Offices of:

 Elizabeth City Signal System
 Summary of Work by
 Intersection (sheet 6 of 6)

Division 1 Pasquotank County Elizabeth City
 PLAN DATE: April 2018 REVIEWED BY: RD Lawton
 PREPARED BY: DJ White REVIEWED BY: LW Moon

REVISIONS: _____ INIT. DATE: _____

N. T. S.

Lisa M. Moon
 3/27/2019
 DATE: _____
 CADD Filename: _____

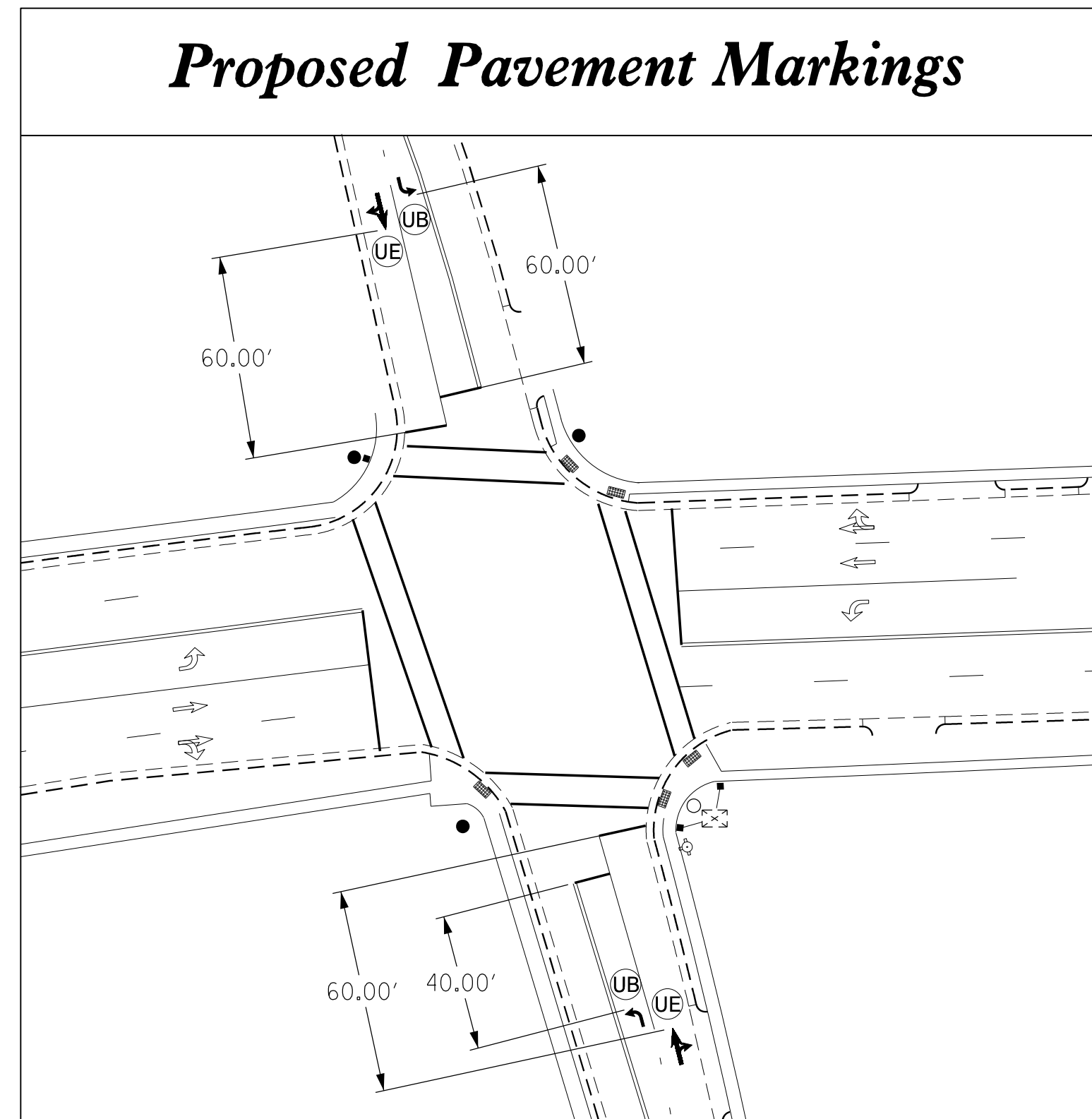

Remove 7 Existing Pavement Marking Arrows
Add 4 Proposed Pavement Marking Arrows

PAVEMENT MARKING SCHEDULE

SYMBOL	DESCRIPTION
	THERMOPLASTIC SYMBOL (90 MILS)
UB	LEFT TURN ARROW
UE	COMBO. RIGHT/STRAIGHT ARROW

ROADWAY STANDARD DRAWING

STD. NO.	TITLE
1205.04	PAVEMENT MARKINGS - INTERSECTIONS
1205.05	PAVEMENT MARKINGS - TURN LANES
1205.06	PAVEMENT MARKINGS - LANE DROPS

20-SEP-2018 11:54
 R:\US942\5107015\MOON\1-0001-08212018g.dgn
 IMON AT CAR-LMCDN-W7

Plans Prepared By:

DRMP, Inc.
8000 Regency Parkway, Suite 175
Cary, NC 27518
NC License No. 5-2213 (919) 650-1038

Signal Upgrade

750 N. Greenfield Pkwy, Garner, NC 27529

SCALE: 1"=40'

US 17 Bus./(W. Ehringhaus St) SR 1268/(E. Ehringhaus St) at US 17 Bus./(S. Road St)/ SR 1269 (S. Road St)	
Division 1 Pasquotank County	Elizabeth City
PLAN DATE: June 2018	REVIEWED BY: AJ Davis
PREPARED BY: DJ White	REVIEWED BY: LM Moon
REVISIONS	INIT. DATE

DOCUMENT NOT CONSIDERED FINAL
UNLESS ALL SIGNATURES COMPLETED

DocuSigned by:
Lisa M. Moon
9/20/2018
DATE: 9/20/2018
SIG. INVENTORY NO. 01-0001

EDI MODEL 2018EClip-NC CONFLICT MONITOR PROGRAMMING DETAIL

(remove jumpers and set switches as shown)

REMOVE DIODE JUMPERS 1-5, 1-6, 1-15, 2-5, 2-6, 2-13, 2-15, 3-8, 3-10, 3-12, 4-7, 4-8, 4-10, 4-12, 4-14, 4-16, 5-13, 6-13, 6-15, 7-10, 7-12, 8-10, 8-12, 8-14, 8-16, 10-12, 10-14, 10-16, 12-14, 12-16, 13-15 and 14-16.

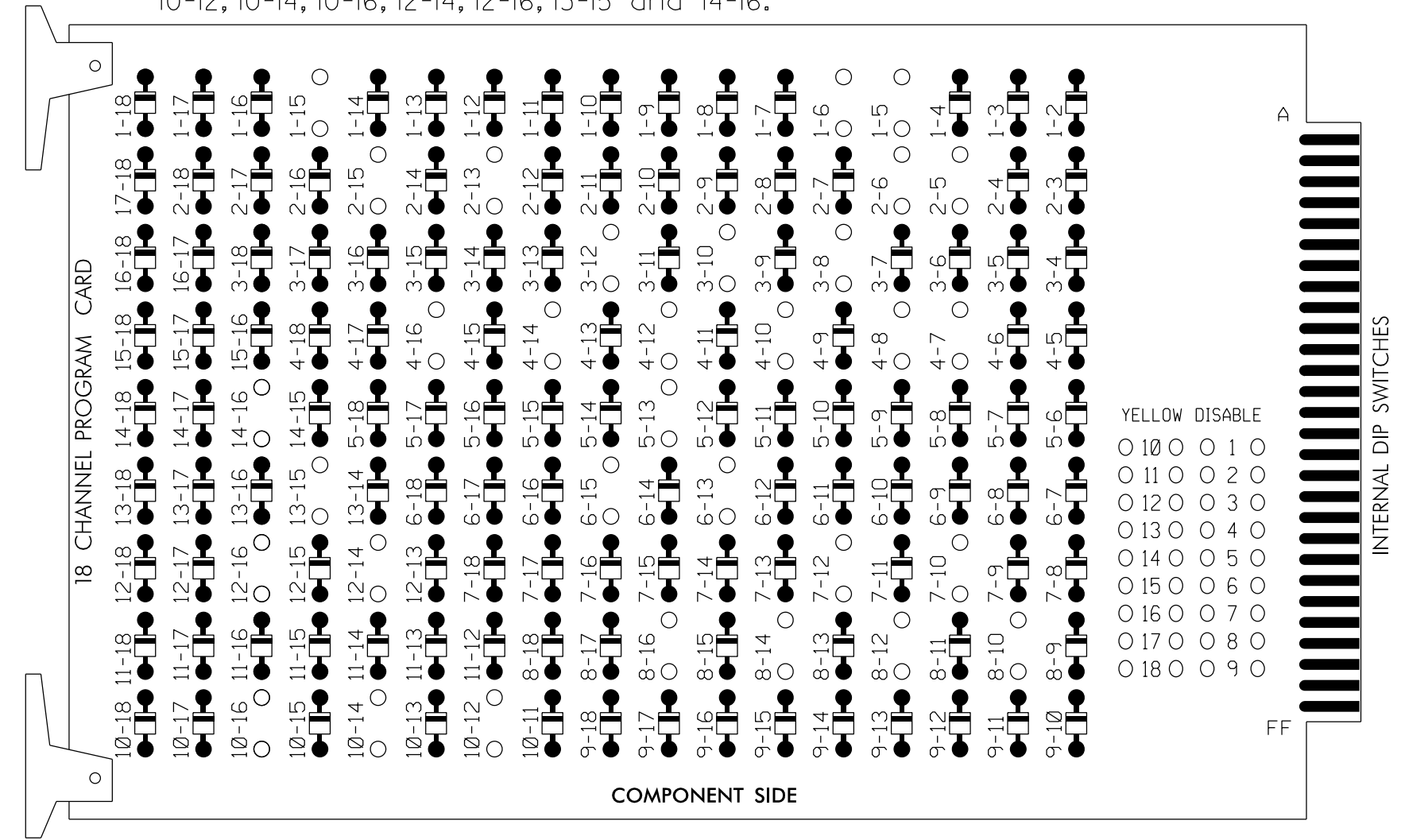

REMOVE JUMPERS AS SHOWN

NOTES:

- Card is provided with all diode jumpers in place. Removal of any jumper allows its channels to run concurrently.
- Ensure jumpers SEL2-SEL5 and SEL9 are present on the monitor board.
- Ensure that Red Enable is active at all times during normal operation.
- Integrate monitor with Ethernet network in cabinet.

NOTES

- To prevent "flash-conflict" problems, insert red flash program blocks for all unused vehicle load switches in the output file. The installer shall verify that signal heads flash in accordance with the Signal Plans.
- Program phases 4 and 8 for dual entry.
- Program controller to start up in phase 2 WALK and 6 WALK.
- The cabinet and controller are part of the Elizabeth City Signal System.

EQUIPMENT INFORMATION

CONTROLLER.....2070LX
 CABINET.....332 W/AUX
 SOFTWARE.....ECONOLITE ASC/3-2070
 CABINET MOUNT.....BASE
 OUTPUT FILE POSITIONS...18 WITH AUX. OUTPUT FILE
 LOAD SWITCHES USED.....S1,S2,S3,S4,S5,S6,S7,S8,S9,S10,
 S11,S12,AUX S2,AUX S5
 PHASES USED.....1,2,2PED,3**,4,4PED,5,6,6PED,
 7**,8,8PED
 OVERLAP "A".....NOT USED
 OVERLAP "B".....*
 OVERLAP "C".....NOT USED
 OVERLAP "D".....*
 * See overlap programming detail on sheet 2
 ** Phase only used during preempt

SIGNAL HEAD HOOK-UP CHART

LOAD SWITCH NO.	S1	S2	S3	S4	S5	S6	S7	S8	S9	S10	S11	S12	AUX S1	AUX S2	AUX S3	AUX S4	AUX S5	AUX S6
CMU CHANNEL NO.	1	2	13	3	4	14	5	6	15	7	8	16	9	10	17	11	12	18
PHASE	1	2	2 PED	3	4	4 PED	5	6	6 PED	7	8	8 PED	OLA	OLB	SPARE	OLC	OLD	SPARE
SIGNAL HEAD NO.	11	21,22	P21, P22	31	41,42	P41, P42	51	61,62	P61, P62	71	81,82	P81, P82	NU	31	NU	NU	71	NU
RED		128			101			134			107							
YELLOW		129		*	102			135		*	108							
GREEN		130			103			136			109							
RED ARROW	125							131						A124				A101
YELLOW ARROW	126							132						A125				A102
FLASHING YELLOW ARROW														A126				A103
GREEN ARROW	127			118				133		124								
Hand				113				104		119				110				
Walking				115				106		121				112				

NU = Not Used

* Denotes install load resistor. See load resistor installation detail this sheet.

★ See pictorial of head wiring in detail this sheet.

COUNTDOWN PEDESTRIAN SIGNAL OPERATION

Countdown Ped Signals are required to display timing only during Ped Clearance Interval. Consult Ped Signal Module user's manual for instructions on selecting this feature.

INPUT FILE POSITION LAYOUT

(front view)

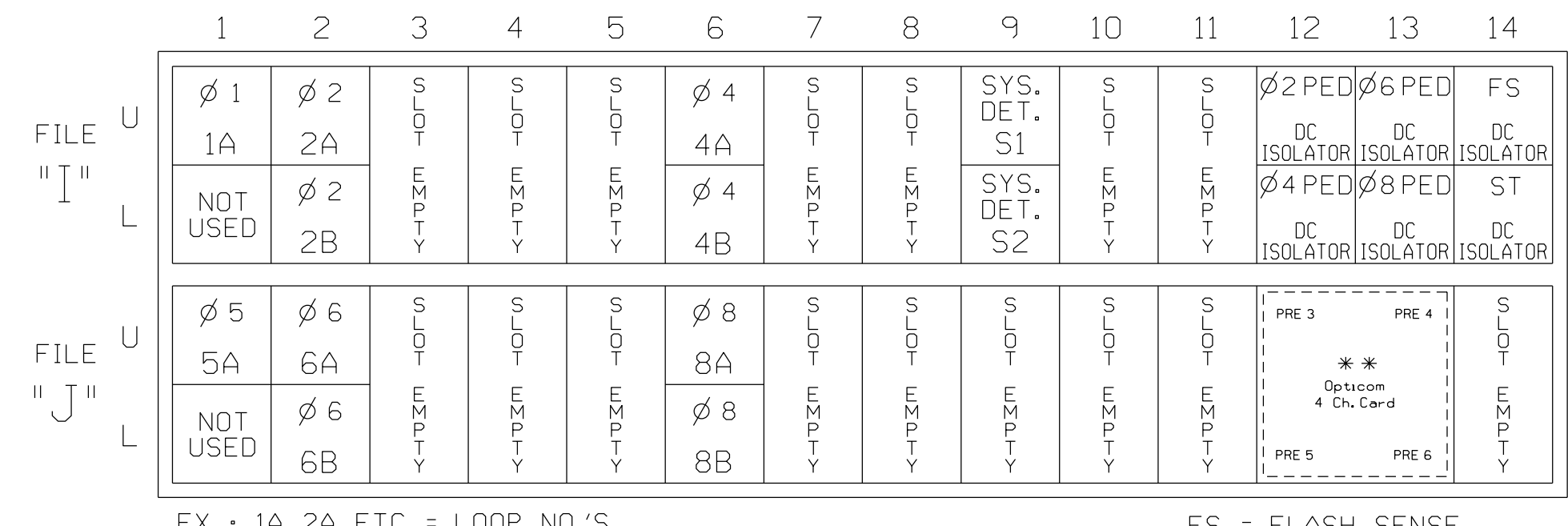

EX: 1A, 2A, ETC. = LOOP NO.'S

FS = FLASH SENSE
 ST = STOP TIME
 PRE = PREEMPT

INPUT FILE CONNECTION & PROGRAMMING CHART

LOOP NO.	LOOP TERMINAL	INPUT FILE POS.	PIN NO.	DETECTOR NO.	NEMA PHASE	CALL	EXTEND TIME	DELAY TIME	ADDED INITIAL	DETECTOR TYPE
1A	TB2-1,2	I1U	56	1	1	YES		3		S
2A	TB2-5,6	I2U	39	2	2	YES				N
2B	TB2-7,8	I2L	43	2	2	YES				N
4A	TB4-9,10	I6U	41	4	4	YES		3		S
4B	TB4-11,12	I6L	45	4	4	YES		10		S
* S1	TB6-9,10	I9U	60	11	SYS	NO				N
* S2	TB6-11,12	I9L	62	13	SYS	NO				N
5A	TB3-1,2	J1U	55	5	5	YES		3		S
6A	TB3-5,6	J2U	40	6	6	YES				N
6B	TB3-7,8	J2L	44	6	6	YES				N
8A	TB5-9,10	J6U	42	8	8	YES		3		S
8B	TB5-11,12	J6L	46	8	8	YES		10		S
PED PUSH BUTTONS										
P21,P22	TB8-4,6	I12U	67	PED 2	2	PED				
P41,P42	TB8-5,6	I12L	69	PED 4	4	PED				
P61,P62	TB8-7,9	I13U	68	PED 6	6	PED				
P81,P82	TB8-8,9	I13L	70	PED 8	8	PED				

NOTE:
 INSTALL DC ISOLATORS IN INPUT FILE SLOTS 112 AND 113.

* System detector only. Remove any assigned vehicle phase.

INPUT FILE POSITION LEGEND: J2L

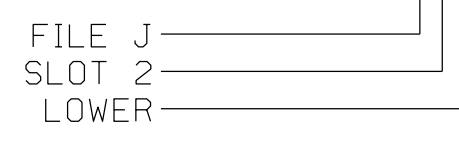

LOAD RESISTOR INSTALLATION DETAIL

(install resistors as shown)

VALUE (ohms)	WATTAGE
1.5K - 1.9K	25W (min)
2.0K - 3.0K	10W (min)

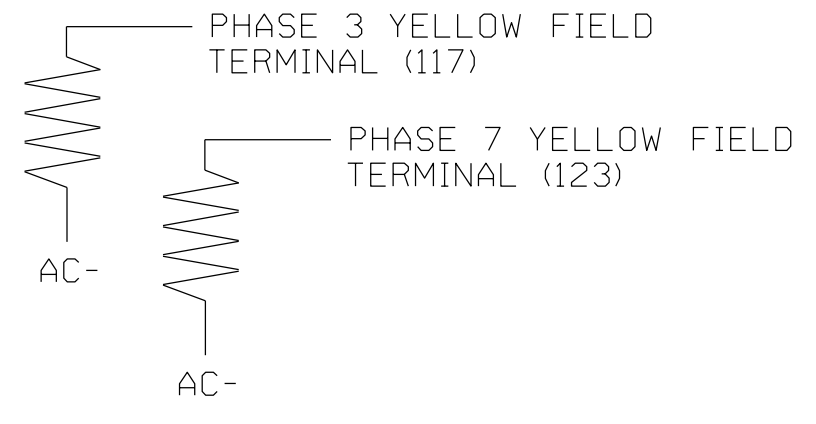

**OPTICAL PREEMPTION SYSTEM

- Install an optical preemption system for emergency vehicle preemption. Perform installation according to manufacturer's directions and NCDOT engineer-approved mounting locations to accomplish the preemption schemes shown on the Signal Design Plans.
- Ensure that the Optical Preemption System is fully compatible with equipment manufactured in accordance with the specification of the type 2070 controller.

FYA SIGNAL WIRING DETAIL

(wire signal heads as shown)



THIS ELECTRICAL DETAIL IS FOR THE SIGNAL DESIGN: 01-0001
 DESIGNED: JUNE 2018
 SEALED: 09/20/2018
 REVISED: N/A

Electrical Detail - Sheet 1 of 3

DRMP, Inc. 8000 Regency Parkway, Suite 175 Cary, NC 27518 NC License No. C-2418 (019) 650-1038

Prepared for the Offices of:
 S.C. Department of Transportation
 Mobility and Safety Division
 STATE OF NORTH CAROLINA
 DEPARTMENT OF TRANSPORTATION
 Signal Management Section

US 17 Bus./(W. Ehringhaus St) SR 1268/(E. Ehringhaus St) at US 17 Bus./(S. Road St)/ SR 1269 (S. Road St)
 Division 1 Pasquotank County Elizabeth City

PLAN DATE: March 2018	REVIEWED BY: AJ Davis
PREPARED BY: DJ White	REVIEWED BY: LM Moon
REVISIONS	INIT. DATE

DOCUMENT NOT CONSIDERED FINAL UNLESS ALL SIGNATURES COMPLETED

SEAL
 NORTH CAROLINA PROFESSIONAL ENGINEER
 SEAL 022516
 LISA M. MOON

DocuSigned by:
 Lisa M. Moon 9/20/2018
 SIG. INVENTORY NO. 01-0001

ECONOLITE ASC/3-2070 EMERGENCY VEHICLE PREEMPT PROGRAMMING DETAIL

(program controller as shown)

1. From Main Menu select 4. PREEMPTOR/TSP

2. From PREEMPTOR/TSP/SCP Submenu select 1. PREEMPT PLAN 1-10

Place cursor in [] next to Preempt Plan and press 3. Then press the right cursor arrow and toggle the controller to YES. Next cursor down. This will select Emergency Vehicle Preempt #3.

```

PREEMPT PLAN [ 3]  ENABLE....YES
  VEH/PED 1 2 3 4 5 6 7 8 9 0 1 2 3 4 5 6
  OVERLAP A B C D E F G H I J K L M N O P
  TRKCLR V . . . . .
  TRKCLR O . . . . .
  ENA TRL . . . . .
  DWEL VEH . X . . X . . . . .
  DWEL PED . . . . .
  DWEL OLP . . . . .
  CYC VEH . . . . .
  CYC PED . . . . .
  CYC OLP . . . . .
  EXIT PH . X . . . X . . . . .
  EXIT CAL . . . . .
  SP FUNC . . . . .

```

```

ENABLE... YESIPMT OVRIDE..INTERLOCK. NO
DET LOCK... XIDELAY.. 0IINHIBIT... 0
OVERIDE FL. .IDURATION 0ICLR-GRN... NO
TERM OLP. NOIPC>YEL YESITERM PH NO
PED DARK.. NOITC RESRV NOIDWELL FL OFF
LINK PMT....0IX FLCOLR REDIEEXIT OPT. OFF
X TMG PLN...0IRE-SERV.. 0IFLT TYPE.HARD
FREE DUR PMTIR1 NOIR2 NOIR3 NOIR4 NO
--TIMING-----WALKIPED CLIMN GRI YELI RED
ENTRANCE TM. 255I 255I 1125.5125.5
-----MIN GRIEXT GRIMX GRI YELI RED
TRACK CLEAR 0I 0I 0I25.5125.5
-----MIN DLIPMTEXTIMX TMI YELI RED
DWL/CYC-EXIT 10I 2.0I 120I25.5125.5
PMT ACTIVE OUT..ON PMT ACT DWELL...NO
OTHER - PRI PMT.OFF NON-PRI PMT.....OFF
INH EXT TIME... 0.0 PED PR RETURN...OFF
PRIORITY RETURN.OFF QUEUE DELAY.... OFF
COND DELAY.....OFF
PHASES 1 2 3 4 5 6 7 8
PR RTN% 0 0 0 0 0 0 0 0
PHASES 9 10 11 12 13 14 15 16
PR RTN% 0 0 0 0 0 0 0 0

```

Place cursor in [] next to Preempt Plan and press 4. Then press the right cursor arrow and toggle the controller to YES. Next cursor down. This will select Emergency Vehicle Preempt #4.

```

PREEMPT PLAN [ 4]  ENABLE....YES
  VEH/PED 1 2 3 4 5 6 7 8 9 0 1 2 3 4 5 6
  OVERLAP A B C D E F G H I J K L M N O P
  TRKCLR V . . . . .
  TRKCLR O . . . . .
  ENA TRL . . . . .
  DWEL VEH X . . . . X . . . . .
  DWEL PED . . . . .
  DWEL OLP . . . . .
  CYC VEH . . . . .
  CYC PED . . . . .
  CYC OLP . . . . .
  EXIT PH . X . . . X . . . . .
  EXIT CAL . . . . .
  SP FUNC . . . . .

```

```

ENABLE... YESIPMT OVRIDE..INTERLOCK. NO
DET LOCK... XIDELAY.. 0IINHIBIT... 0
OVERIDE FL. .IDURATION 0ICLR-GRN... NO
TERM OLP. NOIPC>YEL YESITERM PH NO
PED DARK.. NOITC RESRV NOIDWELL FL OFF
LINK PMT....0IX FLCOLR REDIEEXIT OPT. OFF
X TMG PLN...0IRE-SERV.. 0IFLT TYPE.HARD
FREE DUR PMTIR1 NOIR2 NOIR3 NOIR4 NO
--TIMING-----WALKIPED CLIMN GRI YELI RED
ENTRANCE TM. 255I 255I 1125.5125.5
-----MIN GRIEXT GRIMX GRI YELI RED
TRACK CLEAR 0I 0I 0I25.5125.5
-----MIN DLIPMTEXTIMX TMI YELI RED
DWL/CYC-EXIT 10I 2.0I 120I25.5125.5
PMT ACTIVE OUT..ON PMT ACT DWELL...NO
OTHER - PRI PMT.OFF NON-PRI PMT.....OFF
INH EXT TIME... 0.0 PED PR RETURN...OFF
PRIORITY RETURN.OFF QUEUE DELAY.... OFF
COND DELAY.....OFF
PHASES 1 2 3 4 5 6 7 8
PR RTN% 0 0 0 0 0 0 0 0
PHASES 9 10 11 12 13 14 15 16
PR RTN% 0 0 0 0 0 0 0 0

```

Place cursor in [] next to Preempt Plan and press 5. Then press the right cursor arrow and toggle the controller to YES. Next cursor down. This will select Emergency Vehicle Preempt #5.

```

PREEMPT PLAN [ 5]  ENABLE....YES
  VEH/PED 1 2 3 4 5 6 7 8 9 0 1 2 3 4 5 6
  OVERLAP A B C D E F G H I J K L M N O P
  TRKCLR V . . . . .
  TRKCLR O . . . . .
  ENA TRL . . . . .
  DWEL VEH . X . . . . X . . . . .
  DWEL PED . . . . .
  DWEL OLP .F1 .F1 . . . . .
  CYC VEH . . . . .
  CYC PED . . . . .
  CYC OLP . . . . .
  EXIT PH . X . . . X . . . . .
  EXIT CAL . . . . .
  SP FUNC . . . . .

```

```

ENABLE... YESIPMT OVRIDE..INTERLOCK. NO
DET LOCK... XIDELAY.. 0IINHIBIT... 0
OVERIDE FL. .IDURATION 0ICLR-GRN... NO
TERM OLP. NOIPC>YEL YESITERM PH NO
PED DARK.. NOITC RESRV NOIDWELL FL OFF
LINK PMT....0IX FLCOLR REDIEEXIT OPT. OFF
X TMG PLN...0IRE-SERV.. 0IFLT TYPE.HARD
FREE DUR PMTIR1 NOIR2 NOIR3 NOIR4 NO
--TIMING-----WALKIPED CLIMN GRI YELI RED
ENTRANCE TM. 255I 255I 1125.5125.5
-----MIN GRIEXT GRIMX GRI YELI RED
TRACK CLEAR 0I 0I 0I25.5125.5
-----MIN DLIPMTEXTIMX TMI YELI RED
DWL/CYC-EXIT 7I 2.0I 120I25.5125.5
PMT ACTIVE OUT..ON PMT ACT DWELL...NO
OTHER - PRI PMT.OFF NON-PRI PMT.....OFF
INH EXT TIME... 0.0 PED PR RETURN...OFF
PRIORITY RETURN.OFF QUEUE DELAY.... OFF
COND DELAY.....OFF
PHASES 1 2 3 4 5 6 7 8
PR RTN% 0 0 0 0 0 0 0 0
PHASES 9 10 11 12 13 14 15 16
PR RTN% 0 0 0 0 0 0 0 0

```

Place cursor in [] next to Preempt Plan and press 6. Then press the right cursor arrow and toggle the controller to YES. Next cursor down. This will select Emergency Vehicle Preempt #6.

```

PREEMPT PLAN [ 6]  ENABLE....YES
  VEH/PED 1 2 3 4 5 6 7 8 9 0 1 2 3 4 5 6
  OVERLAP A B C D E F G H I J K L M N O P
  TRKCLR V . . . . .
  TRKCLR O . . . . .
  ENA TRL . . . . .
  DWEL VEH . . . X . . X . . . . .
  DWEL PED . . . . .
  DWEL OLP .F1 .F1 . . . . .
  CYC VEH . . . . .
  CYC PED . . . . .
  CYC OLP . . . . .
  EXIT PH . X . . . X . . . . .
  EXIT CAL . . . . .
  SP FUNC . . . . .

```

```

ENABLE... YESIPMT OVRIDE..INTERLOCK. NO
DET LOCK... XIDELAY.. 0IINHIBIT... 0
OVERIDE FL. .IDURATION 0ICLR-GRN... NO
TERM OLP. NOIPC>YEL YESITERM PH NO
PED DARK.. NOITC RESRV NOIDWELL FL OFF
LINK PMT....0IX FLCOLR REDIEEXIT OPT. OFF
X TMG PLN...0IRE-SERV.. 0IFLT TYPE.HARD
FREE DUR PMTIR1 NOIR2 NOIR3 NOIR4 NO
--TIMING-----WALKIPED CLIMN GRI YELI RED
ENTRANCE TM. 255I 255I 1125.5125.5
-----MIN GRIEXT GRIMX GRI YELI RED
TRACK CLEAR 0I 0I 0I25.5125.5
-----MIN DLIPMTEXTIMX TMI YELI RED
DWL/CYC-EXIT 7I 2.0I 120I25.5125.5
PMT ACTIVE OUT..ON PMT ACT DWELL...NO
OTHER - PRI PMT.OFF NON-PRI PMT.....OFF
INH EXT TIME... 0.0 PED PR RETURN...OFF
PRIORITY RETURN.OFF QUEUE DELAY.... OFF
COND DELAY.....OFF
PHASES 1 2 3 4 5 6 7 8
PR RTN% 0 0 0 0 0 0 0 0
PHASES 9 10 11 12 13 14 15 16
PR RTN% 0 0 0 0 0 0 0 0

```

THIS ELECTRICAL DETAIL IS FOR THE SIGNAL DESIGN: 01-0001
 DESIGNED: JUNE 2018
 SEALED: 09/20/2018
 REVISED: N/A



Electrical Detail - Sheet 3 of 3



ELECTRICAL AND PROGRAMMING DETAILS FOR:		US 17 Bus./(W. Ehringhaus St) SR 1268/(E. Ehringhaus St) at US 17 Bus./(S. Road St)/ SR 1269 (S. Road St)	
Prepared for the Offices of:		Division 1 Pasquotank County Elizabeth City	
PLAN DATE: June 2018	REVIEWED BY: AJ Davis	PREPARED BY: DJ White	REVIEWED BY: LM Moon
REVISIONS	INIT.	DATE	

DOCUMENT NOT CONSIDERED FINAL UNLESS ALL SIGNATURES COMPLETED

SEAL
 NORTH CAROLINA PROFESSIONAL ENGINEER
 SEAL 022516
 LISA M. MOON
 DocuSigned by: Lisa M. Moon 9/20/2018
 SIG. INVENTORY NO. 01-0001

20-SEP-2018 18:51 R:\415942\451\001\4001\1\0001\1\0001-0001-20180821.e.dgn

EDI MODEL 2018EClip-NC CONFLICT MONITOR PROGRAMMING DETAIL

(remove jumpers and set switches as shown)

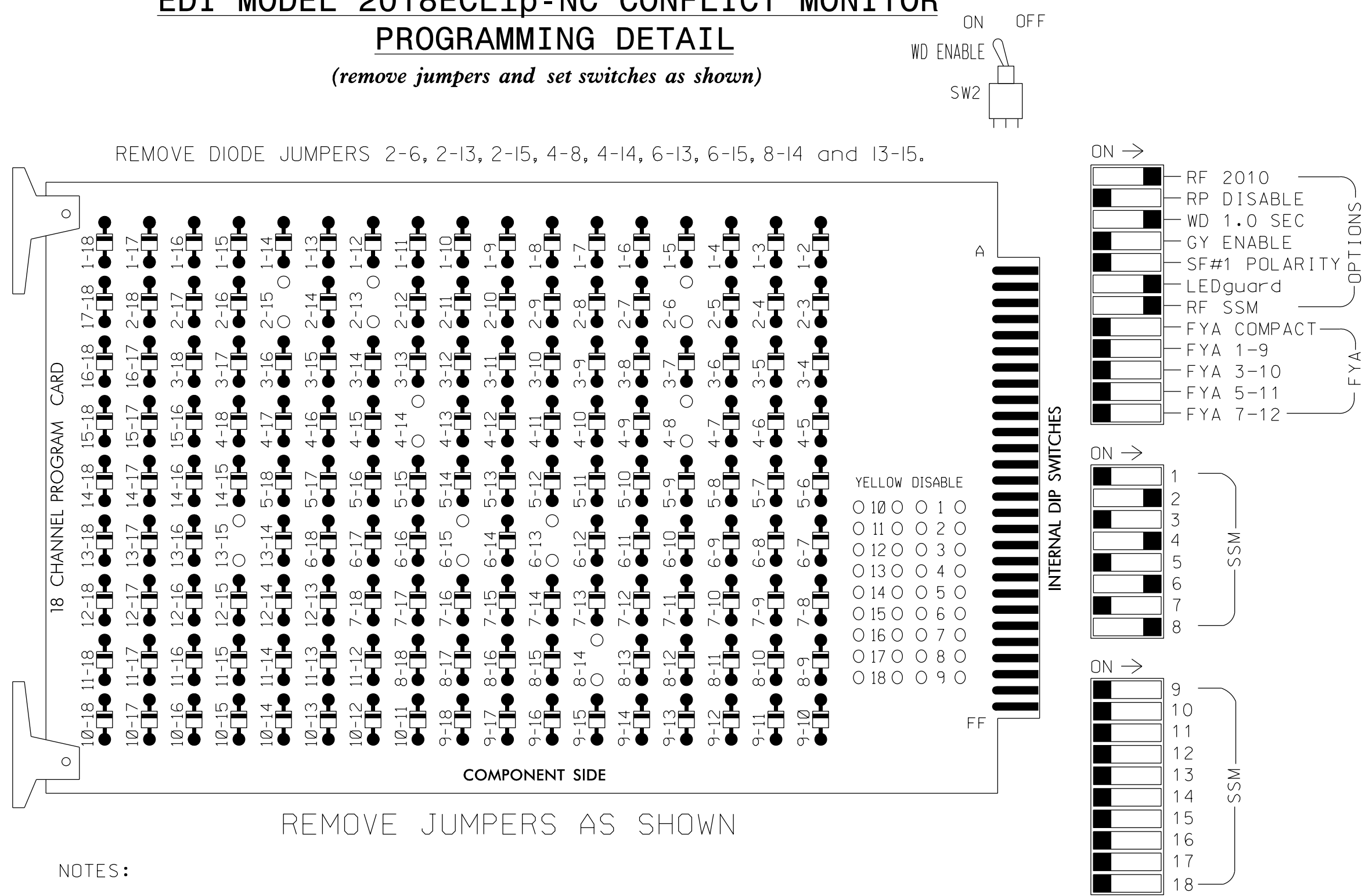

NOTES:

1. Card is provided with all diode jumpers in place. Removal of any jumper allows its channels to run concurrently.
2. Ensure jumpers SEL2-SEL5 and SEL9 are present on the monitor board.
3. Ensure that Red Enable is active at all times during normal operation.
4. Integrate monitor with Ethernet network in cabinet.

NOTES

1. To prevent "flash-conflict" problems, insert red flash program blocks for all unused vehicle load switches in the output file. The installer shall verify that signal heads flash in accordance with the Signal Plans.
2. Program phases 4 and 8 for Dual Entry.
3. Program controller to start up in phase 2 WALK and 6 WALK.
4. The cabinet and controller are part of the Elizabeth City Signal System.

5. Ensure Delayed Green times shown in the Timing Chart on the signal design plan are accounted for to facilitate leading pedestrian interval.

EQUIPMENT INFORMATION

CONTROLLER.....2070LX
 CABINET.....332 W/AUX
 SOFTWARE.....ECONOLITE ASC/3-2070
 CABINET MOUNT.....BASE
 OUTPUT FILE POSITIONS...18 WITH AUX. OUTPUT FILE
 LOAD SWITCHES USED.....S2,S3,S5,S6,S8,S9,S11
 PHASES USED.....2,2PED,4,4PED,6,6PED,8
 OVERLAP "A".....NOT USED
 OVERLAP "B".....NOT USED
 OVERLAP "C".....NOT USED
 OVERLAP "D".....NOT USED

SIGNAL HEAD HOOK-UP CHART

LOAD SWITCH NO.	S1	S2	S3	S4	S5	S6	S7	S8	S9	S10	S11	S12	AUX S1	AUX S2	AUX S3	AUX S4	AUX S5	AUX S6
CMU CHANNEL NO.	1	2	13	3	4	14	5	6	15	7	8	16	9	10	17	11	12	18
PHASE	1	2	2 PED	3	4	4 PED	5	6	6 PED	7	8	8 PED	OLA	OLB	SPARE	OLC	OLD	SPARE
SIGNAL HEAD NO.	NU	21,22	P21, P22	NU	41,42	P41, P42	NU	61,62	P61, P62	NU	81,82	NU	NU	NU	NU	NU	NU	NU
RED		128			101			134			107							
YELLOW		129			102			135			108							
GREEN		130			103			136			109							
RED ARROW																		
YELLOW ARROW																		
GREEN ARROW																		
				113				104			119							
				115				106			121							

NU = Not Used

COUNTDOWN PEDESTRIAN SIGNAL OPERATION

Countdown Ped Signals are required to display timing only during Ped Clearance Interval. Consult Ped Signal Module user's manual for instructions on selecting this feature.

INPUT FILE POSITION LAYOUT

(front view)

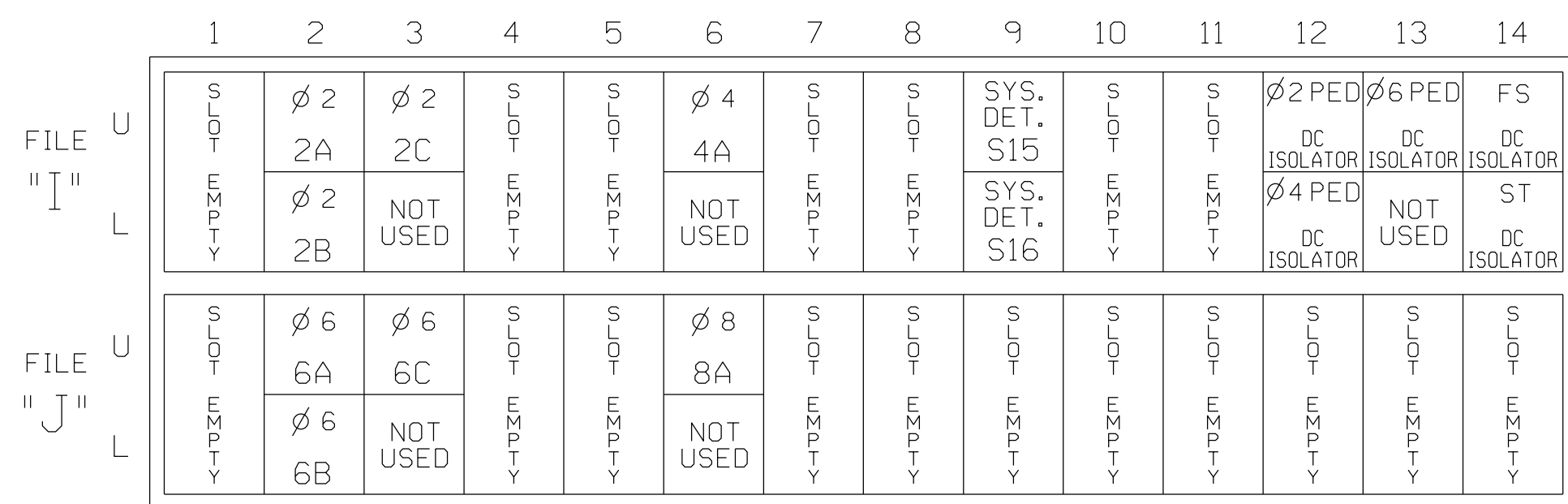

EX. : 1A, 2A, ETC. = LOOP NO.'S

FS = FLASH SENSE
 ST = STOP TIME

INPUT FILE CONNECTION & PROGRAMMING CHART

LOOP NO.	LOOP TERMINAL	INPUT FILE POS.	PIN NO.	DETECTOR NO.	NEMA PHASE	CALL	EXTEND TIME	DELAY TIME	ADDED INITIAL	DETECTOR TYPE
2A	TB2-5,6	I2U	39	2	2	YES				S
2B	TB2-7,8	I2L	43	12	2	YES				S
2C	TB2-9,10	I3U	63	32	2	YES				S
4A	TB4-9,10	I6U	41	4	4	YES		5		S
* S15	TB6-9,10	I9U	60	11	SYS	NO				N
* S16	TB6-11,12	I9L	62	13	SYS	NO				N
6A	TB3-5,6	J2U	40	6	6	YES				S
6B	TB3-7,8	J2L	44	16	6	YES				S
6C	TB3-9,10	J3U	64	36	6	YES				S
8A	TB5-9,10	J6U	42	8	8	YES		5		S
PED PUSH BUTTONS										
P21,P22	TB8-4,6	I12U	67	PED 2	2 PED					
P41,P42	TB8-5,6	I12L	69	PED 4	4 PED					
P61,P62	TB8-7,9	I13U	68	PED 6	6 PED					

NOTE:
 INSTALL DC ISOLATORS
 IN INPUT FILE SLOTS
 112 AND 113.

* System detector only. Remove any assigned vehicle phase.

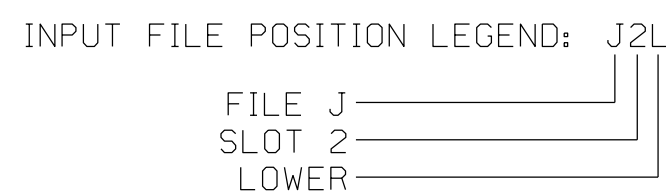

THIS ELECTRICAL DETAIL IS FOR
 THE SIGNAL DESIGN: 01-0002
 DESIGNED: FEBRUARY 2018
 SEALED: 08/21/2018
 REVISED: N/A

Electrical Detail - Sheet 1 of 2

ELECTRICAL AND PROGRAMMING DETAILS FOR:	SR 1268 (Ehringhaus Street) at S. McMorrine Street	DOCUMENT NOT CONSIDERED FINAL UNLESS ALL SIGNATURES COMPLETED
Prepared for the Offices of: 	Division 1 Pasquotank County Elizabeth City	SEAL
Plans Prepared By: DRMP <small>DRMP, Inc. 8000 Regency Parkway, Suite 175 Cary, NC 27519 NC License No. C-2213 (919) 650-1038</small>	PREPARED BY: JA Le REVIEWED BY: AJ Davis PREPARED BY: JA Le REVIEWED BY: LM Moon	Date Signed by: Lisa M. Moon 9/20/2018 <small>58CE88B03D0421</small> DATE
<small>750 N. Greenfield Pkwy, Garner, NC 27529</small>	REVISIONS INIT. DATE	SIG. INVENTORY NO. 01-0002

ECONOLITE ASC/3-2070 PED 4 PROGRAMMING ASSIGNMENT DETAIL

(program controller as shown)

1. From Main Menu select 6. DETECTORS
2. From DETECTOR Submenu select 3. PED DETECTOR INPUT ASSIGNMENT

PED DET PHASE ASSIGNMENT MODE: NTCIP								
PHASE	1	2	3	4	5	6	7	8
DETECTOR	0	2	0	4	0	6	0	4
PHASE	9	10	11	12	13	14	15	16
DETECTOR	0	0	0	0	0	0	0	0

← NOTICE PED DETECTOR 4
ASSIGNED TO PHASE 4 & 8

THIS ELECTRICAL DETAIL IS FOR
THE SIGNAL DESIGN: 01-0002
DESIGNED: FEBRUARY 2018
SEALED: 08/21/2018
REVISED: N/A

Electrical Detail - Sheet 2 of 2

DOCUMENT NOT CONSIDERED
FINAL UNLESS ALL
SIGNATURES COMPLETED

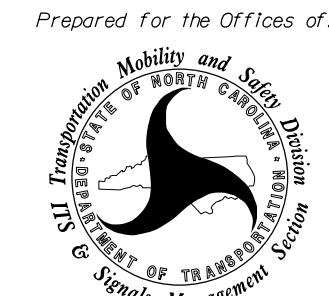
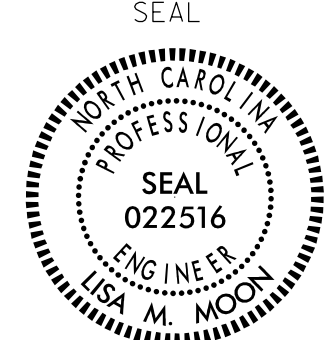
<p>ELECTRICAL AND PROGRAMMING DETAILS FOR:</p> <p style="font-size: small;">Prepared for the Offices of:</p> <div style="text-align: center;">  <p>Department of Transportation Signal Management Section</p> </div>	<p>SR 1268 (Ehringhaus Street) at S. McMorrine Street</p> <p>Division 1 Pasquotank County Elizabeth City</p> <p>PLAN DATE: February 2018 REVIEWED BY: AJ Davis</p> <p>PREPARED BY: DJ White REVIEWED BY: LM Moon</p> <table border="1" style="width: 100%; border-collapse: collapse;"> <thead> <tr> <th>REVISIONS</th> <th>INIT.</th> <th>DATE</th> </tr> </thead> <tbody> <tr><td> </td><td> </td><td> </td></tr> <tr><td> </td><td> </td><td> </td></tr> <tr><td> </td><td> </td><td> </td></tr> </tbody> </table>	REVISIONS	INIT.	DATE										<p style="text-align: center;">SEAL</p> <div style="text-align: center;">  <p>PROFESSIONAL ENGINEER LISA M. MOON</p> </div> <p style="font-size: small;">DocuSigned by: <i>Lisa M. Moon</i> 9/20/2018</p> <p style="font-size: x-small;">DATE: _____ SIG. INVENTORY NO. 01-0002</p>
REVISIONS	INIT.	DATE												

Plans Prepared By:



DRMP

DRMP, Inc.
8000 Regency Parkway, Suite 175
Cary, NC 27519
NC License No. C-2213 (919) 650-1038

750 N. Greenfield Pkwy, Garner, NC 27529

PHASING DIAGRAM

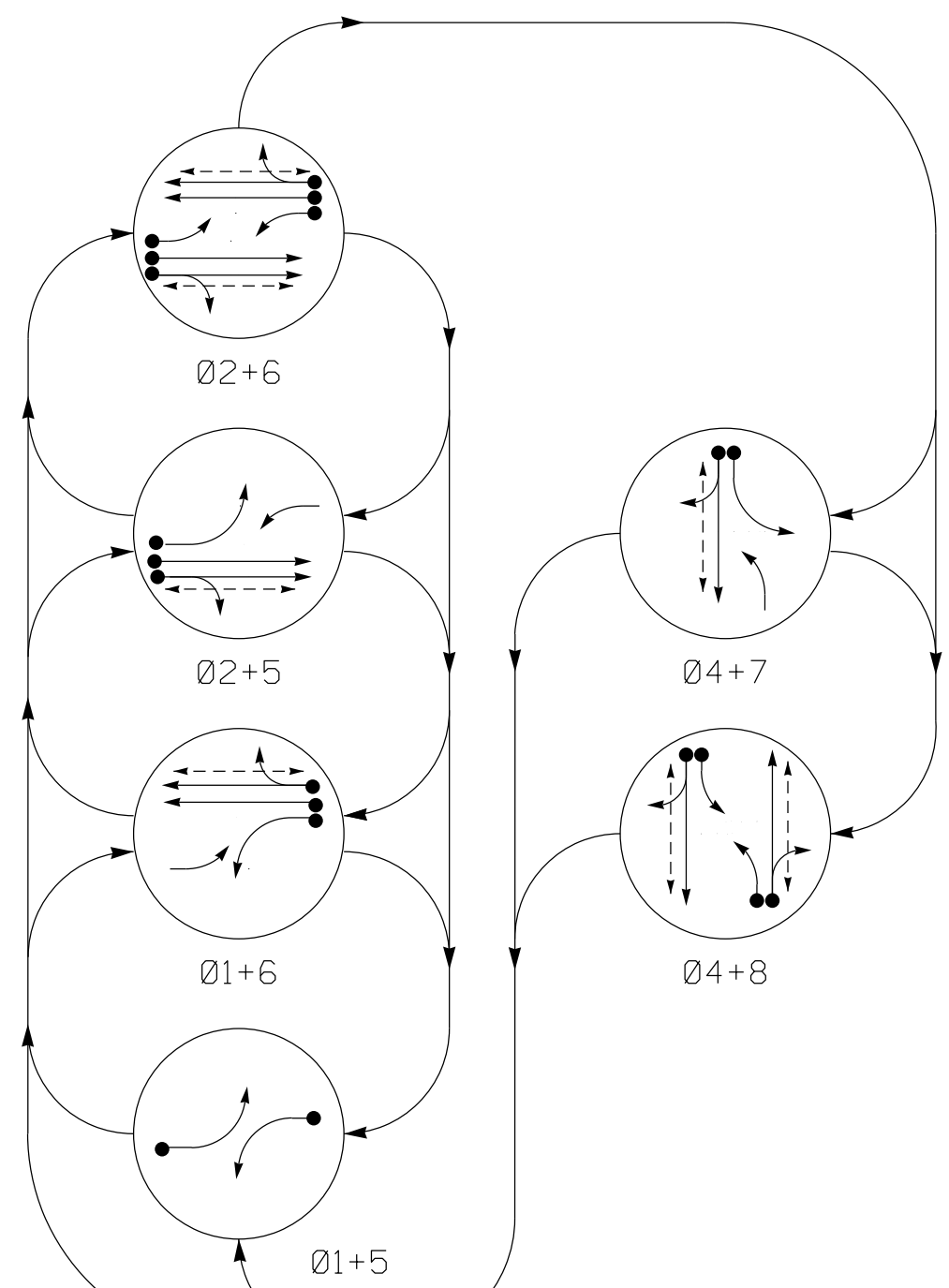

EV PREEMPT PHASES

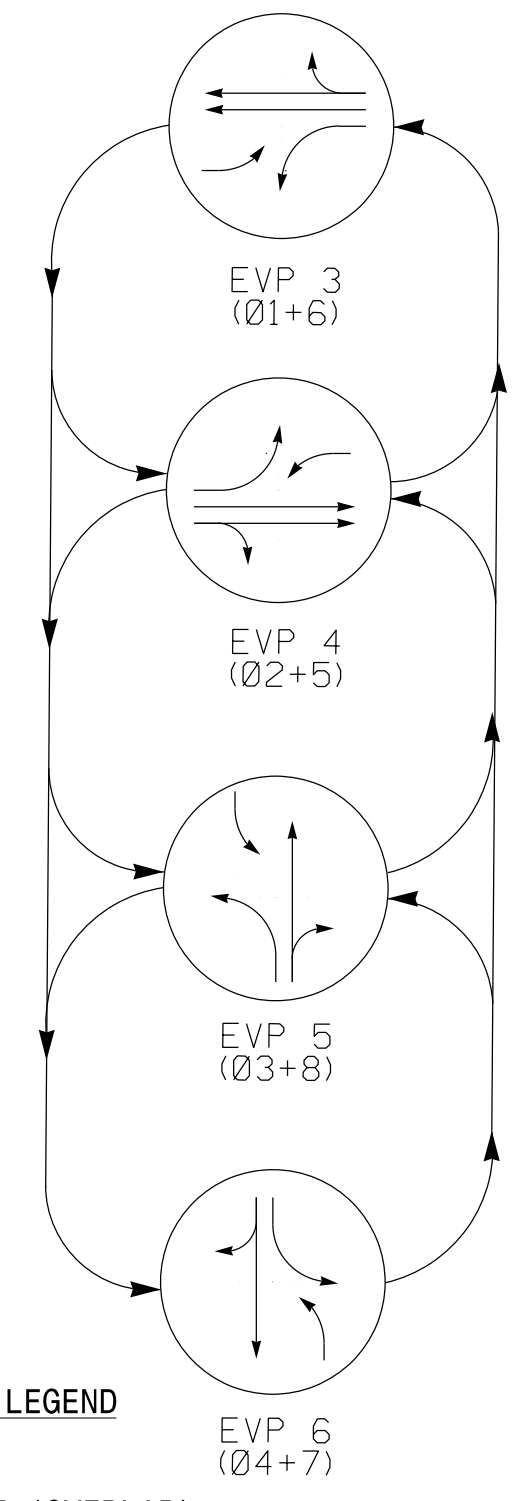

PHASING DIAGRAM DETECTION LEGEND

- DETECTED MOVEMENT
- UNDETECTED MOVEMENT (OVERLAP)
- UNSIGNALIZED MOVEMENT
- ⇄ PEDESTRIAN MOVEMENT

TABLE OF OPERATION

SIGNAL FACE	PHASE										
	01+5	01+6	02+5	02+6	04+7	04+8	EVP 3	EVP 4	EVP 5	EVP 6	FLASH
11	←	←	←	←	←	←	←	←	←	←	←
21, 22	R	R	G	G	R	R	R	G	R	R	Y
31	←	←	←	←	←	←	←	←	←	←	←
41, 42	R	R	R	R	G	G	R	R	R	G	R
51	←	←	←	←	←	←	←	←	←	←	←
61, 62	R	G	R	G	R	R	G	R	R	R	Y
71	←	←	←	←	←	←	←	←	←	←	←
81, 82	R	R	R	R	R	G	R	R	G	R	R
P21, P22	DW	DW	W	W	DW	DW	DW	DW	DW	DW	DRK
P41, P42	DW	DW	DW	W	W	DW	DW	DW	DW	DW	DRK
P61, P62	DW	W	DW	W	DW	DW	DW	DW	DW	DW	DRK
P81, P82	DW	DW	DW	DW	W	DW	DW	DW	DW	DW	DRK

SIGNAL FACE I.D.

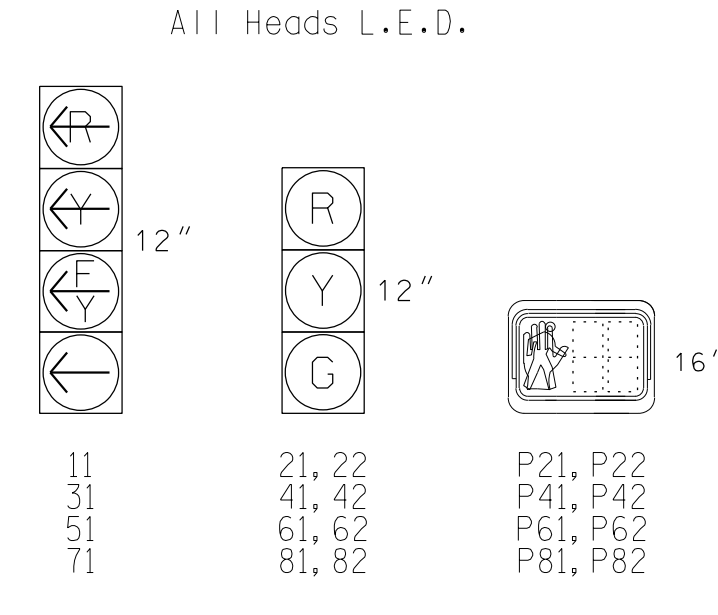

ASC/3 DETECTOR INSTALLATION CHART

LOOP	SIZE (FT)	DISTANCE FROM STOPBAR (FT)	TURNS	NEW LOOP	PROGRAMMING							
					PHASE	CALLING	EXTEND TIME	DELAY TIME	USE ADDED INITIAL	TYPE	LOOP SYSTEM	NEW CARD
1A	6X40	0	*	-	1	Yes	-	15	-	S	-	X
2A	6X6	70	*	-	2	Yes	-	3	-	S	-	X
2B	6X6	70	*	-	2	Yes	-	-	-	S	-	X
4A	6X40	0	*	-	4	Yes	-	10	-	S	-	X
5A	6X40	0	*	-	5	Yes	-	15	-	S	-	X
6A	6X6	70	*	-	6	Yes	-	-	-	S	-	X
6B	6X6	70	*	-	6	Yes	-	-	-	S	-	X
7A	6X40	0	*	-	7	Yes	-	15	-	S	-	X
8A	6X6	0	*	-	8	Yes	-	3	-	S	-	X
8B	6X6	0	*	-	8	Yes	-	10	-	S	-	X
S1	6X6	+95	*	-	-	-	-	-	-	N	X	X
S2	6X6	+95	*	-	-	-	-	-	-	N	X	X
S3	6X6	+165	*	-	-	-	-	-	-	N	X	X

* Wireless Detection Zone

ASC/3 EV PREEMPT

FUNCTION	PRE 3	PRE 4	PRE 5	PRE 6
Exit Phase(s)	2.6	2.6	2.6	2.6
Preempt Override	OFF	OFF	OFF	OFF
Delay Time	0	0	0	0
Ped Clear Through Yellow	Y	Y	Y	Y
Terminate Phases	N	N	N	N
Entrance Walk	255*	255*	255*	255*
Entrance Ped Clear	255*	255*	255*	255*
Entrance Min Green	1	1	1	1
Entrance Yellow Change	25.5*	25.5*	25.5*	25.5*
Entrance Red Clear	25.5*	25.5*	25.5*	25.5*
Minimum Dwell Time	10	10	7	7
Preempt Input Extension Time	2	2	2	2
Preempt Max Time	120	120	120	120
Exit Yellow Change	25.5*	25.5*	25.5*	25.5*
Exit Red Clear	25.5*	25.5*	25.5*	25.5*

* Allows normal phase times to be used.

ASC/3 TIMING CHART

FEATURE	PHASE							
	1	2	3	4	5	6	7	8
Min Green *	7	10	7	7	7	10	7	7
Delay Green	-	-	-	7	-	-	-	7
Walk *	0	7	-	7	0	7	0	7
Ped Clear	0	9	-	15	0	8	0	15
Veh. Extension *	2.0	3.0	-	2.0	2.0	3.0	2.0	2.0
Max 1 *	15	30	-	30	15	30	15	30
Yellow	3.0	3.8	3.0	3.3	3.0	3.8	3.0	3.3
Red Clear	2.3	1.6	2.4	2.8	2.4	1.6	2.6	2.8
Actuations B4 Add *	-	-	-	-	-	-	-	-
Seconds /Actuation *	-	-	-	-	-	-	-	-
Max Initial *	-	-	-	-	-	-	-	-
Time Before Reduction *	-	-	-	-	-	-	-	-
Time To Reduce *	-	-	-	-	-	-	-	-
Minimum Gap	-	-	-	-	-	-	-	-
Locking Detector	-	X	-	-	-	X	-	-
Recall Position	-	VEH. RECALL	-	-	-	VEH. RECALL	-	-
Dual Entry	-	-	-	X	-	-	-	X
Simultaneous Gap	X	X	X	X	X	X	X	X

* These values may be field adjusted. Do not adjust Min Green and Extension times for phases 2 and 6 lower than what is shown. Min Green for all other phases should not be lower than 4 seconds.

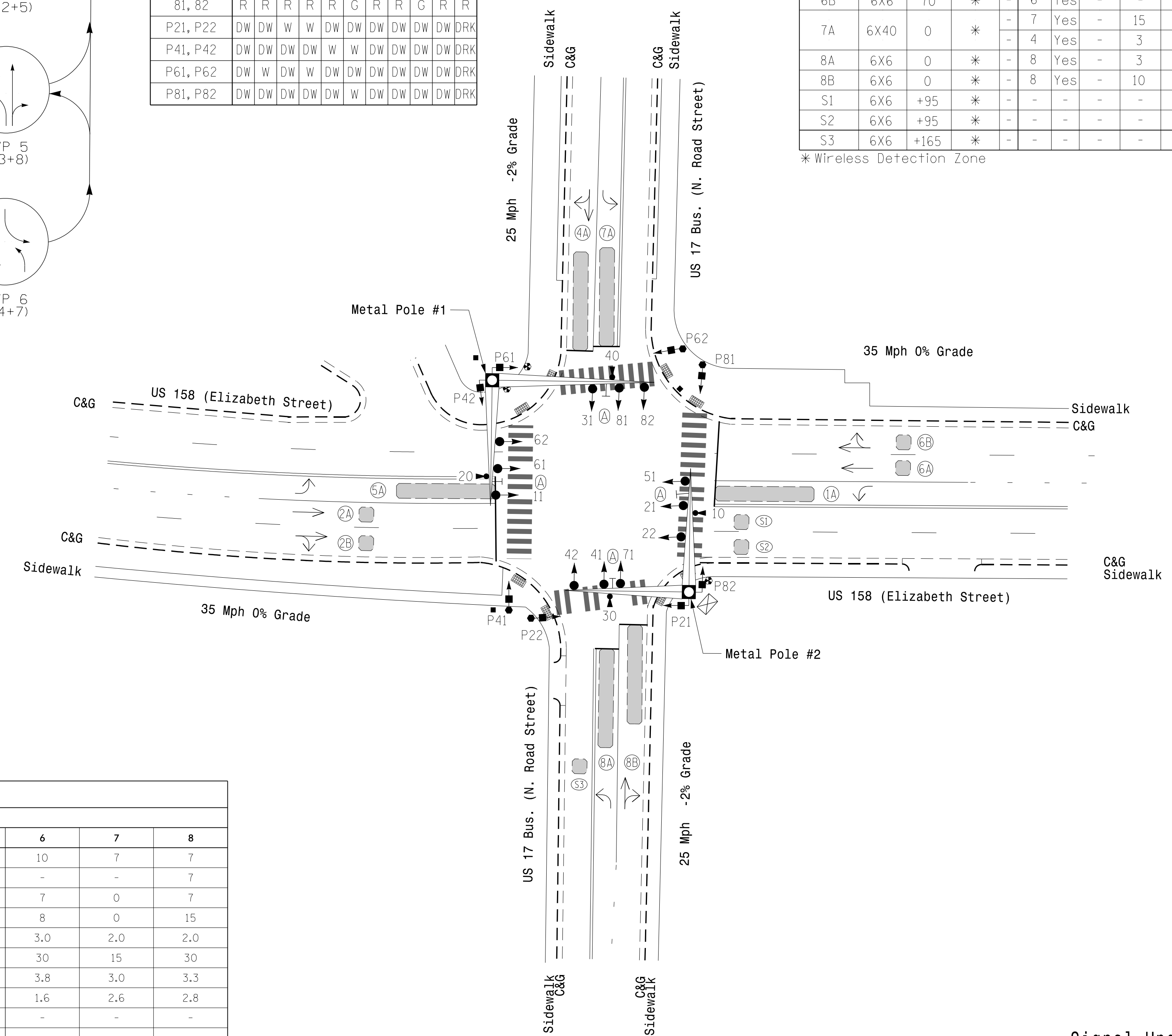

6 Phase Fully Actuated w/ EV Preemption (Elizabeth City Signal System)

NOTES

- Refer to "Roadway Standard Drawings NCDOT" dated January 2018 and "Standard Specifications for Roads and Structures" dated January 2018.
- Do not program signal for late night flashing operation unless otherwise directed by the Engineer.
- Phase 1 and/or phase 5 may be lagged.
- Phase 7 may be lagged.
- Renumber existing head 81 as 31. Renumber existing heads 82 & 83 as 81 & 82 respectively.
- Set all detector units to presence mode.
- Locate new cabinet so as not to obstruct sight distance of vehicles turning right on red.
- Omit "WALK" and flashing "DON'T WALK" with no pedestrian calls.
- Program pedestrian heads to countdown the flashing "Don't Walk" time only.
- Pavement markings are existing.
- This intersection features an optical preemption system. Shown locations of optical detectors are conceptual only.
- Relocate existing optical preemption equipment from existing cabinet to new cabinet.
- Relocate existing wireless detection equipment from existing cabinet to new cabinet.
- Optical detector 10 calls EVP 3; Optical detector 20 calls EVP 4; Optical detector 30 calls EVP 5; Optical detector 40 calls EVP 6.
- Maximum times shown in timing chart are for free-run operation only. Coordinated signal system timing values supersede these values.

LEGEND

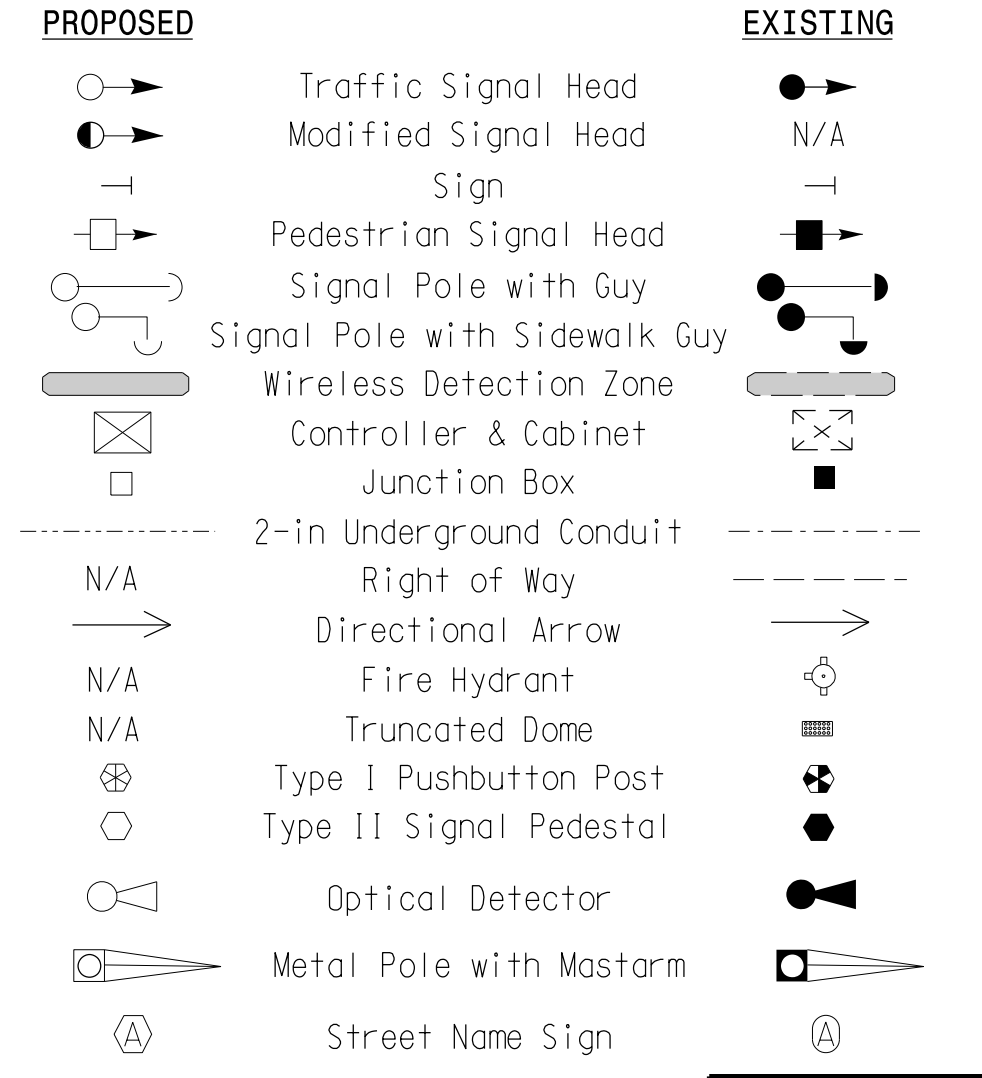

Signal Upgrade

Prepared for the Offices of:

 Department of Transportation and Safety
 STATE OF NORTH CAROLINA
 Signal Design Section
 750 N. Greenfield Pkwy, Garner, NC 27529

US 158 (Elizabeth Street) at US 17 Bus. (N. Road Street)

Divison 1 Pasquotank County Elizabeth City
 PLAN DATE: March 2018 REVIEWED BY: AJ Davis
 PREPARED BY: JA Le REVIEWED BY: LM Moon

REVISIONS: _____ INIT: _____ DATE: _____

SEAL

 Lisa M. Moon
 ENGINEER
 License No. 022516
 State of North Carolina
 DATE: 9/20/2018
 SIG. INVENTORY NO. 01-0004

Plans Prepared By:

DRMP
 DRMP, Inc.
 8000 Regency Parkway, Suite 175
 Cary, NC 27519
 NC License No. C-2213 (919) 650-1038

20-SEP-2018 16:34
 R:\415942\415942.dwg
 AT: CAR-L\MOON-LM
 20-SEP-2018 16:34
 R:\415942\415942.dwg
 AT: CAR-L\MOON-LM

DOCUMENT NOT CONSIDERED FINAL UNLESS ALL SIGNATURES COMPLETED

EDI MODEL 2018ECLip-NC CONFLICT MONITOR PROGRAMMING DETAIL

(remove jumpers and set switches as shown)

REMOVE DIODE JUMPERS 1-5, 1-6, 1-9, 1-11, 1-15, 2-5, 2-6, 2-9, 2-11, 2-13, 2-15, 3-8, 3-12, 4-7, 4-8, 4-10, 4-12, 4-14, 4-16, 5-9, 5-11, 5-13, 6-9, 6-11, 6-13, 6-15, 7-10, 7-12, 7-14, 8-10, 8-12, 8-14, 8-16, 9-11, 9-13, 9-15, 10-12, 10-14, 10-16, 11-13, 11-15, 12-14, 12-16, 13-15 and 14-16.

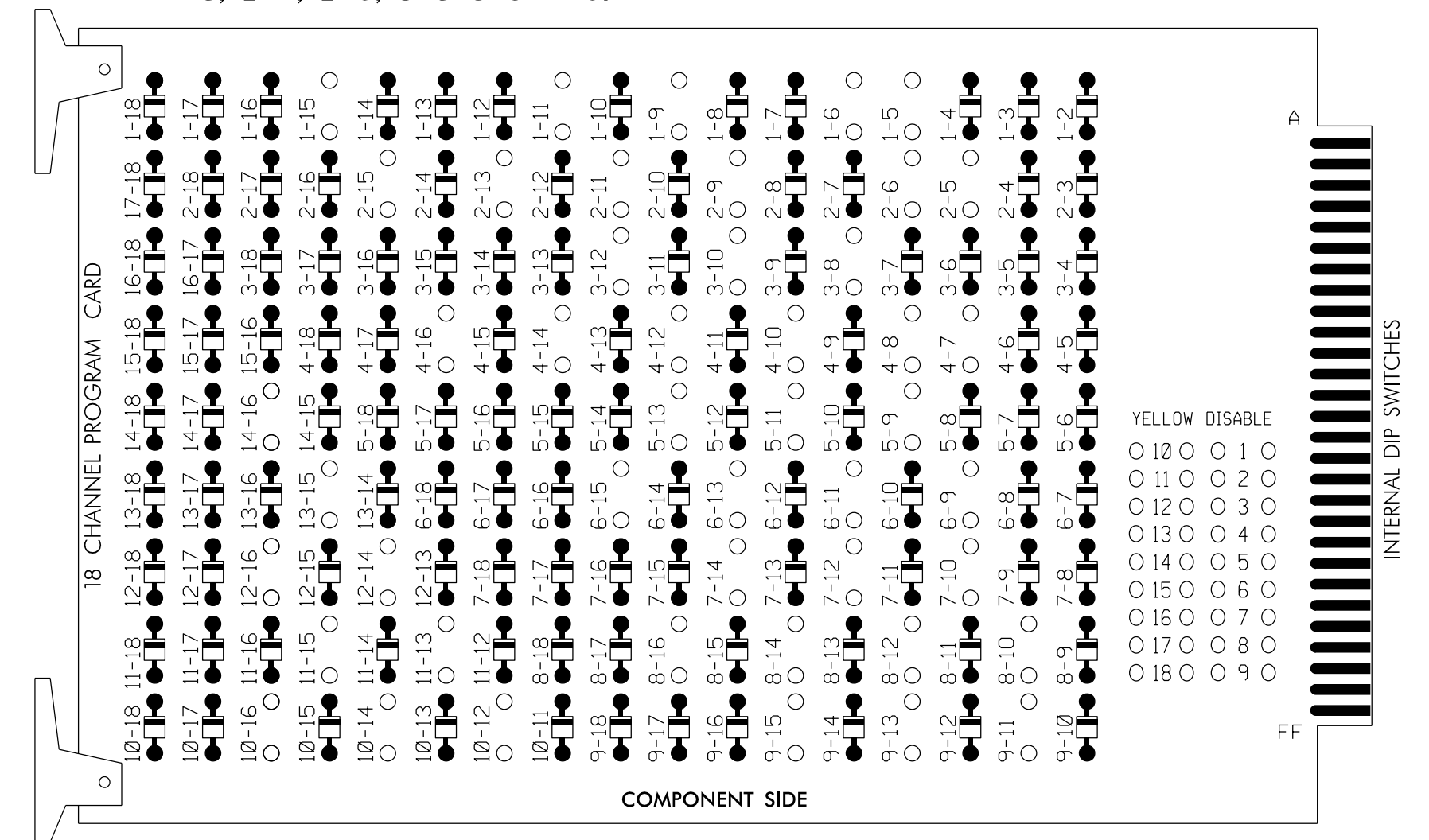

REMOVE JUMPERS AS SHOWN

NOTES:

- Card is provided with all diode jumpers in place. Removal of any jumper allows its channels to run concurrently.
- Ensure jumpers SEL2-SEL5 and SEL9 are present on the monitor board.
- Ensure that Red Enable is active at all times during normal operation.
- Integrate monitor with Ethernet network in cabinet.

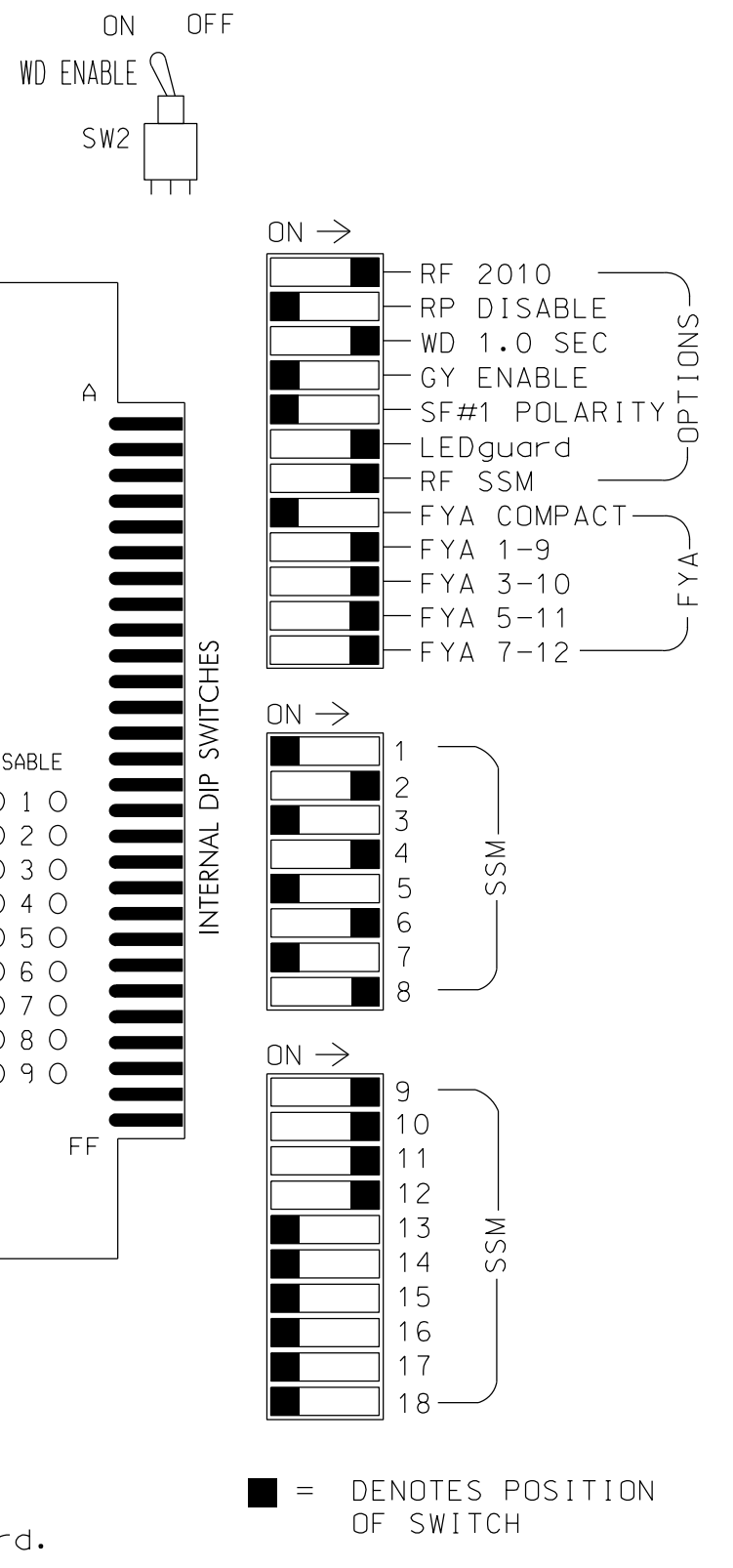

NOTES

- To prevent "flash-conflict" problems, insert red flash program blocks for all unused vehicle load switches in the output file. The installer shall verify that signal heads flash in accordance with the Signal Plans.
- Program phases 4 and 8 for Dual Entry.
- Program controller to start up in phase 2 WALK and 6 WALK.
- The cabinet and controller are part of the Elizabeth City Signal System.
- Ensure Delayed Green times shown in the Timing Chart on the signal design plan are accounted for to facilitate leading pedestrian interval.

EQUIPMENT INFORMATION

CONTROLLER.....2070LX
 CABINET.....332 W/AUX
 SOFTWARE.....ECONOLITE ASC/3-2070
 CABINET MOUNT.....BASE
 OUTPUT FILE POSITIONS...18 WITH AUX. OUTPUT FILE S11,S12,AUX S1,AUX S2,AUX S4,AUX S5
 LOAD SWITCHES USED.....S1,S2,S3,S4,S5,S6,S7,S8,S9,S10,S11,S12,AUX S1,AUX S2,AUX S4,AUX S5
 PHASES USED.....1,2,2PED,3**,4,4PED,5,6,6PED,7,8,8PED
 OVERLAP "A".....*
 OVERLAP "B".....*
 OVERLAP "C".....*
 OVERLAP "D".....*
 * See overlap programming detail on sheet 2
 ** Phase only used during preempt

SIGNAL HEAD HOOK-UP CHART

LOAD SWITCH NO.	S1	S2	S3	S4	S5	S6	S7	S8	S9	S10	S11	S12	AUX S1	AUX S2	AUX S3	AUX S4	AUX S5	AUX S6
CMU CHANNEL NO.	1	2	13	3	4	14	5	6	15	7	8	16	9	10	17	11	12	18
PHASE	1	2	2 PED	3	4	4 PED	5	6	6 PED	7	8	8 PED	OLA	OLB	SPARE	OLC	OLD	SPARE
SIGNAL HEAD NO.	11	21,22	P21, P22	31	41,42	P41, P42	51	61,62	P61, P62	71	81,82	P81, P82	11	31	NU	51	71	NU
RED		128		101			134			107								
YELLOW	*	129		102			135			108								
GREEN		130		103			136			109								
RED ARROW													A121	A124		A114	A101	
YELLOW ARROW													A122	A125		A115	A102	
FLASHING YELLOW ARROW													A123	A126		A116	A103	
GREEN ARROW	127		118		133		124											
Hand			113		104		119			110								
Walker			115		106		121			112								

NU = Not Used
 * Denotes install load resistor. See load resistor installation detail on sheet 2.
 ★ See pictorial of head wiring in detail on sheet 2.

COUNTDOWN PEDESTRIAN SIGNAL OPERATION

Countdown Ped Signals are required to display timing only during Ped Clearance Interval. Consult Ped Signal Module user's manual for instructions on selecting this feature.

FLASHER CIRCUIT MODIFICATION DETAIL

IN ORDER TO ENSURE THAT SIGNALS FLASH CONCURRENTLY ON THE SAME APPROACH, MAKE THE FOLLOWING FLASHER CIRCUIT CHANGES:

- ON REAR OF PDA - REMOVE WIRE FROM TERM. T2-4 AND TERMINATE ON T2-2.
- ON REAR OF PDA - REMOVE WIRE FROM TERM. T2-5 AND TERMINATE ON T2-3.
- REMOVE FLASHER UNIT 2.

THE CHANGES LISTED ABOVE TIES ALL PHASES AND OVERLAPS TO FLASHER UNIT 1.

INPUT FILE POSITION LAYOUT (front view)

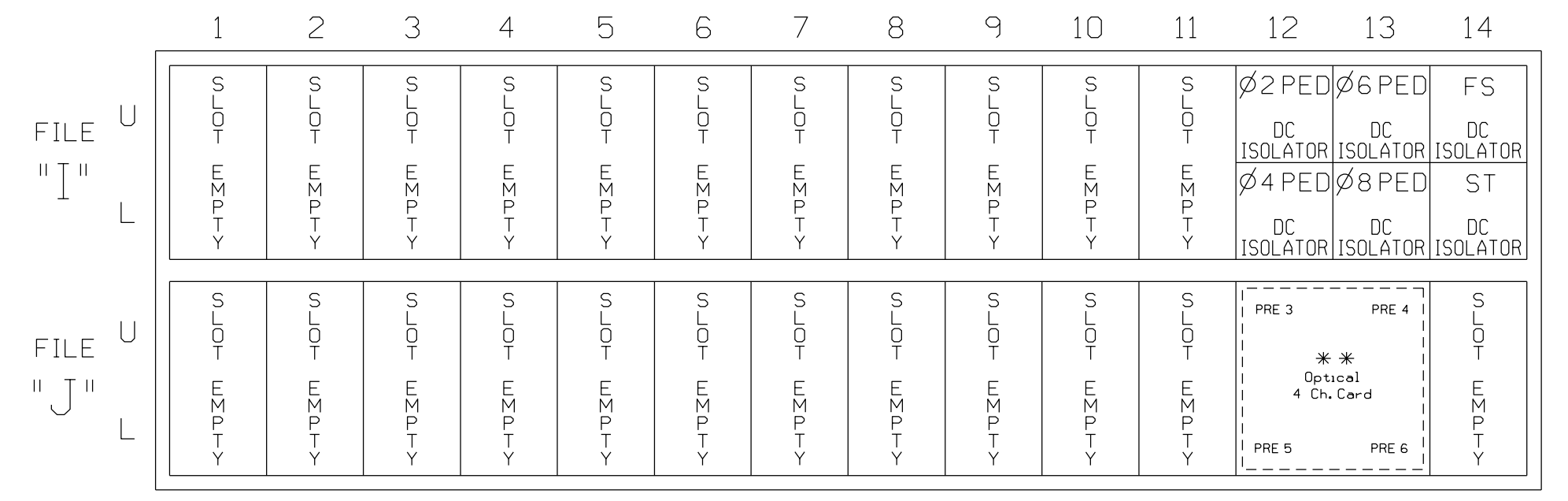

EX.: 1A, 2A, ETC. = LOOP NO.'S
 * See Sensys Access Box Wiring Detail this sheet.
 FS = FLASH SENSE
 ST = STOP TIME
 EV PREEMPT = PRE3, PRE4, PRE5 & PRE6

INPUT FILE CONNECTION & PROGRAMMING CHART

LOOP NO.	LOOP TERMINAL	INPUT FILE POS.	PIN NO.	DETECTOR NO.	NEMA PHASE	CALL	EXTEND TIME	DELAY TIME	ADDED INITIAL	DETECTOR TYPE
PED PUSH BUTTONS										
P21,P22	TB8-4,6	I12U	67	PED 2	2 PED					
P41,P42	TB8-5,6	I12L	69	PED 4	4 PED					
P61,P62	TB8-7,9	I13U	68	PED 6	6 PED					
P81,P82	TB8-8,9	I13L	70	PED 8	8 PED					

NOTE:
 INSTALL DC ISOLATORS IN INPUT FILE SLOTS 112 AND 113.

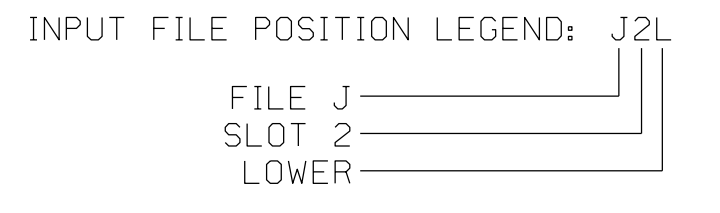

**OPTICAL PREEMPTION SYSTEM

- Install an optical preemption system for emergency vehicle preemption. Perform installation according to manufacturer's directions and NCDOT engineer-approved mounting locations to accomplish the preemption schemes shown on the Signal Design Plans.
- Ensure that the Optical Preemption System is fully compatible with equipment manufactured in accordance with the specification of the type 2070 controller.

WIRELESS DETECTION SYSTEM

- For all zones install a Wireless Vehicle Detection System for vehicle detection. Perform installation according to manufacturer's directions and NCDOT Engineer-approved mounting locations to accomplish the detection schemes shown on the signal design plans.
- Ensure that the Wireless Vehicle Detection System is fully compatible with equipment manufactured in accordance with the specifications for the type 2070 controller.

THIS ELECTRICAL DETAIL IS FOR THE SIGNAL DESIGN: 01-0004
 DESIGNED: MARCH 2018
 SEALED: 09/20/2018
 REVISED: N/A

Electrical Detail - Sheet 1 of 4

Electrical and Programming Details For:

Prepared for the Offices of:

DRMP, Inc.
 8000 Regency Parkway, Suite 175
 Cary, NC 27519
 NC License No. C-2215 (919) 650-1038

US 158 (Elizabeth Street) at US 17 Bus. (N. Road Street)	
Divison 1 Pasquotank County	Elizabeth City
PLAN DATE: March 2018	REVIEWED BY: AJ Davis
PREPARED BY: DJ White	REVIEWED BY: LM Moon
REVISIONS	INIT. DATE

DOCUMENT NOT CONSIDERED FINAL UNLESS ALL SIGNATURES COMPLETED

SEAL

LISA M. MOON
 ENGINEER

DocuSigned by: Lisa M. Moon
 9/20/2018
 DATE
 SIG. INVENTORY NO. 01-0004

20-SEP-2018 18:51
 R:\05942\51and\shades\gnw\l:\mg01-0004-20180821.e.dgn
 l:\mcon AT CAR-LMCDM-W7

ECONOLITE ASC/3-2070 LOGIC PROCESSOR PROGRAMMING DETAIL FOR LEADING PED INTERVAL (DELAYED GREEN) & PREEMPT ONLY PHASE OMIT

(program controller as shown)

The following logic processor configuration holds the FYA's on signal heads 31 and 71 red for the duration of the delayed green time (leading ped interval) when serving a ped call on the opposing through phase.

1. From Main Menu select 1. CONFIGURATION
2. From CONFIGURATION Submenu select 8. LOGIC PROCESSOR
3. From the LOGIC PROCESSOR Submenu select 2. LOGIC STATEMENTS

ENTER A "1" IN THE LP# FIELD, PRESS 'ENTER', AND PROGRAM AS SHOWN.

LP#:	1	COPY FROM:	1	ACTIVE:	M	(T/F)
IF	PED ON PH WALK		4	IS	ON	
AND	VEH GREEN ON PH		4	IS	OFF	
THEN	SIG SET OLP RED		2		ON	
	SIG SET OLP YELLOW		2		OFF	
	SIG SET OVLP GREEN		2		OFF	
ELSE						

HOLD SIGNAL HEAD 31 FYA RED DURING THE PHASE 4 DELAYED GREEN TIME (LEADING PED INTERVAL)

ENTER A "2" IN THE LP# FIELD, PRESS 'ENTER', AND PROGRAM AS SHOWN.

LP#:	2	COPY FROM:	2	ACTIVE:	M	(T/F)
IF	PED ON PH WALK		8	IS	ON	
AND	VEH GREEN ON PH		8	IS	OFF	
THEN	SIG SET OLP RED		4		ON	
	SIG SET OLP YELLOW		4		OFF	
	SIG SET OVLP GREEN		4		OFF	
ELSE						

HOLD SIGNAL HEAD 71 FYA RED DURING THE PHASE 8 DELAYED GREEN TIME (LEADING PED INTERVAL)

ENTER A "3" IN THE LP# FIELD, PRESS 'ENTER', AND PROGRAM AS SHOWN.

LP#:	3	COPY FROM:	3	ACTIVE:	M	(T/F)
IF	PMT PREEMPT ACTIVE		5	IS	OFF	
THEN	CTR OMIT PHASE		3		ON	
ELSE						

LOGIC FOR OMITTING PHASE 3 AT STARTUP AND/OR WHEN NOT IN PREEMPT

4. From the LOGIC PROCESSOR Submenu select 1. LOGIC STATEMENT CONTROL

ENABLE LOGIC PROCESSOR STATEMENTS 1-6 BY POSITIONING THE CURSOR OVER THE FIELDS SHOWN BELOW AND USING THE TOGGLE KEY TO ENABLE THEM .

LOGIC STATEMENT CONTROL												
	1	2	3	4	5	6	7	8	9	0	1	2
LP 1-15	E	E	E
LP 16-30
LP 31-45
LP 46-60
LP 61-75
LP 76-90

END PROGRAMMING

ECONOLITE ASC/3-2070 PREEMPT FILTERING PROGRAMMING DETAIL

(program controller as shown)

1. From Main Menu select 4. PREEMPTOR/TSP
2. From PREEMPT/TSP/SCP Submenu select 2. ENABLE PREEMPT FILTERING & TSP/SCP

ENABLE PREEMPT FILTERING & TSP/SCP		
FILTERED	SOLID	PULSING
INPUT	1 ...BYPASSED..	...BYPASSED..
	2 ...BYPASSED..	...BYPASSED..
	3 ..PREEMPT	3. ...BYPASSED..
	4 ..PREEMPT	4. ...BYPASSED..
	5 ..PREEMPT	5. ...BYPASSED..
	6 ..PREEMPT	6. ...BYPASSED..
	7 ...BYPASSED..	...BYPASSED..
	8 ...BYPASSED..	...BYPASSED..
	9 ...BYPASSED..	...BYPASSED..
	10 ...BYPASSED..	...BYPASSED..

THIS ELECTRICAL DETAIL IS FOR THE SIGNAL DESIGN: 01-0004
 DESIGNED: MARCH 2018
 SEALED: 09/20/2018
 REVISED: N/A

Electrical Detail - Sheet 3 of 4

DOCUMENT NOT CONSIDERED FINAL UNLESS ALL SIGNATURES COMPLETED

<p style="font-size: x-small;">ELECTRICAL AND PROGRAMMING DETAILS FOR:</p> <p style="font-size: x-small;">Prepared for the Offices of:</p> <p style="font-size: x-small;">DRMP, Inc. 8000 Regency Parkway, Suite 175 Cary, NC 27519 NC License No. C-2215 (019) 650-1038</p>	<p style="font-size: large; font-weight: bold;">US 158 (Elizabeth Street) at US 17 Bus. (N. Road Street)</p> <p style="font-size: small;">Divison 1 Pasquotank County Elizabeth City</p> <p style="font-size: x-small;">PLAN DATE: March 2018 REVIEWED BY: AJ Davis</p> <p style="font-size: x-small;">PREPARED BY: DJ White REVIEWED BY: LM Moon</p> <table border="1" style="width: 100%; border-collapse: collapse; font-size: x-small;"> <tr> <th>REVISIONS</th> <th>INIT.</th> <th>DATE</th> </tr> <tr> <td> </td> <td> </td> <td> </td> </tr> </table>	REVISIONS	INIT.	DATE				<p style="font-size: x-small;">SEAL</p> <p style="font-size: x-small;">DocuSigned by: <i>Lisa M. Moon</i> 9/20/2018</p> <p style="font-size: x-small;">SIG. INVENTORY NO. 01-0004</p>
REVISIONS	INIT.	DATE						

ECONOLITE ASC/3-2070 EMERGENCY VEHICLE PREEMPT PROGRAMMING DETAIL

(program controller as shown)

- 1. From Main Menu select 4. PREEMPTOR/TSP
- 2. From PREEMPTOR/TSP/SCP Submenu select 1. PREEMPT PLAN 1-10

Place cursor in [] next to Preempt Plan and press 3. Then press the right cursor arrow and toggle the controller to YES. Next cursor down. This will select Emergency Vehicle Preempt #3.

Place cursor in [] next to Preempt Plan and press 4. Then press the right cursor arrow and toggle the controller to YES. Next cursor down. This will select Emergency Vehicle Preempt #4.

Place cursor in [] next to Preempt Plan and press 5. Then press the right cursor arrow and toggle the controller to YES. Next cursor down. This will select Emergency Vehicle Preempt #5.

Place cursor in [] next to Preempt Plan and press 6. Then press the right cursor arrow and toggle the controller to YES. Next cursor down. This will select Emergency Vehicle Preempt #6.

```

PREEMPT PLAN [ 3]  ENABLE....YES
VEH/PED 1 2 3 4 5 6 7 8 9 0 1 2 3 4 5 6
OVERLAP A B C D E F G H I J K L M N O P
TRKCLR V . . . . .
TRKCLR O . . . . .
ENA TRL . . . . .
DWEL VEH X . . . . X . . . . .
DWEL PED . . . . .
DWEL OLPF1 .F1 . . . . .
CYC VEH . . . . .
CYC PED . . . . .
CYC OLP . . . . .
EXIT PH . X . . . X . . . . .
EXIT CAL . . . . .
SP FUNC . . . . .

ENABLE... YESIPMT OVRIDE..IINTERLOCK. NO
DET LOCK... XIDELAY.. 0IINHIBIT... 0
OVERRIDE FL. .IDURATION 0ICLR-GRN... NO
TERM OLP. NOIPC>YEL YESITERM PH NO
PED DARK.. NOITC RESRV NOIDWELL FL OFF
LINK PMT....0IX FLCOLR REDIEEXIT OPT. OFF
X TMG PLN...0IRE-SERV.. 0IFLT TYPE.HARD
FREE DUR PMTIR1 NOIR2 NOIR3 NOIR4 NO
--TIMING-----WALKIPED CLIMN GRI YELI RED
ENTRANCE TM. 255I 255I 1125.5125.5
-----MIN GRIEXT GRIMX GRI YELI RED
TRACK CLEAR 0I 0I 0I25.5125.5
-----MIN DLIPMTEXTIMX TMI YELI RED
DWL/CYC-EXIT 10I 2.0I 120I25.5125.5
PMT ACTIVE OUT..ON PMT ACT DWELL...NO
OTHER - PRI PMT.OFF NON-PRI PMT....OFF
INH EXT TIME... 0.0 PED PR RETURN...OFF
PRIORITY RETURN.OFF QUEUE DELAY.... OFF
COND DELAY.....OFF
PHASES 1 2 3 4 5 6 7 8
PR RTN% 0 0 0 0 0 0 0 0
PHASES 9 10 11 12 13 14 15 16
PR RTN% 0 0 0 0 0 0 0 0

```

```

PREEMPT PLAN [ 4]  ENABLE....YES
VEH/PED 1 2 3 4 5 6 7 8 9 0 1 2 3 4 5 6
OVERLAP A B C D E F G H I J K L M N O P
TRKCLR V . . . . .
TRKCLR O . . . . .
ENA TRL . . . . .
DWEL VEH . X . . . X . . . . .
DWEL PED . . . . .
DWEL OLPF1 .F1 . . . . .
CYC VEH . . . . .
CYC PED . . . . .
CYC OLP . . . . .
EXIT PH . X . . . X . . . . .
EXIT CAL . . . . .
SP FUNC . . . . .

ENABLE... YESIPMT OVRIDE..IINTERLOCK. NO
DET LOCK... XIDELAY.. 0IINHIBIT... 0
OVERRIDE FL. .IDURATION 0ICLR-GRN... NO
TERM OLP. NOIPC>YEL YESITERM PH NO
PED DARK.. NOITC RESRV NOIDWELL FL OFF
LINK PMT....0IX FLCOLR REDIEEXIT OPT. OFF
X TMG PLN...0IRE-SERV.. 0IFLT TYPE.HARD
FREE DUR PMTIR1 NOIR2 NOIR3 NOIR4 NO
--TIMING-----WALKIPED CLIMN GRI YELI RED
ENTRANCE TM. 255I 255I 1125.5125.5
-----MIN GRIEXT GRIMX GRI YELI RED
TRACK CLEAR 0I 0I 0I25.5125.5
-----MIN DLIPMTEXTIMX TMI YELI RED
DWL/CYC-EXIT 10I 2.0I 120I25.5125.5
PMT ACTIVE OUT..ON PMT ACT DWELL...NO
OTHER - PRI PMT.OFF NON-PRI PMT....OFF
INH EXT TIME... 0.0 PED PR RETURN...OFF
PRIORITY RETURN.OFF QUEUE DELAY.... OFF
COND DELAY.....OFF
PHASES 1 2 3 4 5 6 7 8
PR RTN% 0 0 0 0 0 0 0 0
PHASES 9 10 11 12 13 14 15 16
PR RTN% 0 0 0 0 0 0 0 0

```

```

PREEMPT PLAN [ 5]  ENABLE....YES
VEH/PED 1 2 3 4 5 6 7 8 9 0 1 2 3 4 5 6
OVERLAP A B C D E F G H I J K L M N O P
TRKCLR V . . . . .
TRKCLR O . . . . .
ENA TRL . . . . .
DWEL VEH . . X . . . . X . . . . .
DWEL PED . . . . .
DWEL OLP .F1 .F1 . . . . .
CYC VEH . . . . .
CYC PED . . . . .
CYC OLP . . . . .
EXIT PH . X . . . X . . . . .
EXIT CAL . . . . .
SP FUNC . . . . .

ENABLE... YESIPMT OVRIDE..IINTERLOCK. NO
DET LOCK... XIDELAY.. 0IINHIBIT... 0
OVERRIDE FL. .IDURATION 0ICLR-GRN... NO
TERM OLP. NOIPC>YEL YESITERM PH NO
PED DARK.. NOITC RESRV NOIDWELL FL OFF
LINK PMT....0IX FLCOLR REDIEEXIT OPT. OFF
X TMG PLN...0IRE-SERV.. 0IFLT TYPE.HARD
FREE DUR PMTIR1 NOIR2 NOIR3 NOIR4 NO
--TIMING-----WALKIPED CLIMN GRI YELI RED
ENTRANCE TM. 255I 255I 1125.5125.5
-----MIN GRIEXT GRIMX GRI YELI RED
TRACK CLEAR 0I 0I 0I25.5125.5
-----MIN DLIPMTEXTIMX TMI YELI RED
DWL/CYC-EXIT 7I 2.0I 120I25.5125.5
PMT ACTIVE OUT..ON PMT ACT DWELL...NO
OTHER - PRI PMT.OFF NON-PRI PMT....OFF
INH EXT TIME... 0.0 PED PR RETURN...OFF
PRIORITY RETURN.OFF QUEUE DELAY.... OFF
COND DELAY.....OFF
PHASES 1 2 3 4 5 6 7 8
PR RTN% 0 0 0 0 0 0 0 0
PHASES 9 10 11 12 13 14 15 16
PR RTN% 0 0 0 0 0 0 0 0

```

```

PREEMPT PLAN [ 6]  ENABLE....YES
VEH/PED 1 2 3 4 5 6 7 8 9 0 1 2 3 4 5 6
OVERLAP A B C D E F G H I J K L M N O P
TRKCLR V . . . . .
TRKCLR O . . . . .
ENA TRL . . . . .
DWEL VEH . . . X . . . X . . . . .
DWEL PED . . . . .
DWEL OLP .F1 .F1 . . . . .
CYC VEH . . . . .
CYC PED . . . . .
CYC OLP . . . . .
EXIT PH . X . . . X . . . . .
EXIT CAL . . . . .
SP FUNC . . . . .

ENABLE... YESIPMT OVRIDE..IINTERLOCK. NO
DET LOCK... XIDELAY.. 0IINHIBIT... 0
OVERRIDE FL. .IDURATION 0ICLR-GRN... NO
TERM OLP. NOIPC>YEL YESITERM PH NO
PED DARK.. NOITC RESRV NOIDWELL FL OFF
LINK PMT....0IX FLCOLR REDIEEXIT OPT. OFF
X TMG PLN...0IRE-SERV.. 0IFLT TYPE.HARD
FREE DUR PMTIR1 NOIR2 NOIR3 NOIR4 NO
--TIMING-----WALKIPED CLIMN GRI YELI RED
ENTRANCE TM. 255I 255I 1125.5125.5
-----MIN GRIEXT GRIMX GRI YELI RED
TRACK CLEAR 0I 0I 0I25.5125.5
-----MIN DLIPMTEXTIMX TMI YELI RED
DWL/CYC-EXIT 7I 2.0I 120I25.5125.5
PMT ACTIVE OUT..ON PMT ACT DWELL...NO
OTHER - PRI PMT.OFF NON-PRI PMT....OFF
INH EXT TIME... 0.0 PED PR RETURN...OFF
PRIORITY RETURN.OFF QUEUE DELAY.... OFF
COND DELAY.....OFF
PHASES 1 2 3 4 5 6 7 8
PR RTN% 0 0 0 0 0 0 0 0
PHASES 9 10 11 12 13 14 15 16
PR RTN% 0 0 0 0 0 0 0 0

```

THIS ELECTRICAL DETAIL IS FOR THE SIGNAL DESIGN: 01-0004
DESIGNED: MARCH 2018
SEALED: 09/20/2018
REVISED: N/A

Electrical Detail - Sheet 4 of 4

DOCUMENT NOT CONSIDERED FINAL UNLESS ALL SIGNATURES COMPLETED

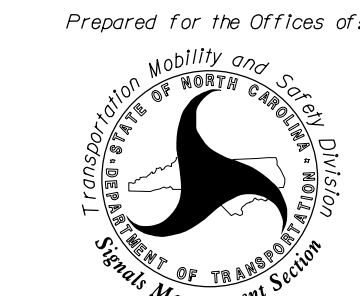
 <p>DRMP, Inc. 8000 Regency Parkway, Suite 175 Cary, NC 27519 NC License No. C-2215 (019) 650-1038</p>	<p>Electrical AND PROGRAMMING DETAILS FOR:</p> <p>Prepared for the Offices of:</p> 	<p>US 158 (Elizabeth Street) at US 17 Bus. (N. Road Street)</p>	<p>SEAL NORTH CAROLINA PROFESSIONAL ENGINEER LISA M. MOON 022516</p>					
	<p>Plans Prepared By:</p>	<p>Divison 1 Pasquotank County Elizabeth City</p>	<p>PLAN DATE: March 2018 REVIEWED BY: AJ Davis</p>	<p>DocuSigned by: Lisa M. Moon 9/20/2018</p>				
	<p>PREPARED BY: DJ White</p>	<p>REVIEWED BY: LM Moon</p>	<p>REVISIONS</p> <table border="1"> <tr> <th>INIT.</th> <th>DATE</th> </tr> <tr> <td> </td> <td> </td> </tr> </table>	INIT.	DATE			<p>SIG. INVENTORY NO. 01-0004</p>
	INIT.	DATE						
<p>750 N. Greenfield Pkwy, Garner, NC 27529</p>	<p>REVISIONS</p>	<p>DATE</p>	<p>DATE</p>					

ECONOLITE ASC/3-2070 OVERLAP PROGRAMMING DETAIL

(program controller as shown)

1. From Main Menu select 2. CONTROLLER
2. From CONTROLLER Submenu select 2. VEHICLE OVERLAPS

OVERLAP B

Select TMG VEH OVLP [B] and 'PPLT FYA'

TMG VEH OVLP...[B] TYPE:PPLT FYA

PROTECTED LEFT TURN.... PHASE 3

OPPOSING THROUGH..... PHASE 4

FLASHING ARROW OUTPUT.....CH10 ISOLATE

DELAY START OF: FYA..0.0 CLEARANCE..0.0

ACTION PLAN SF BIT DISABLE..... 0

Toggle Twice

↓

OVERLAP D

Select TMG VEH OVLP [D] and 'PPLT FYA'

TMG VEH OVLP...[D] TYPE:PPLT FYA

PROTECTED LEFT TURN.... PHASE 7

OPPOSING THROUGH..... PHASE 8

FLASHING ARROW OUTPUT.....CH12 ISOLATE

DELAY START OF: FYA..0.0 CLEARANCE..0.0

ACTION PLAN SF BIT DISABLE..... 0

END PROGRAMMING

FYA SIGNAL WIRING DETAIL

(wire signal heads as shown)

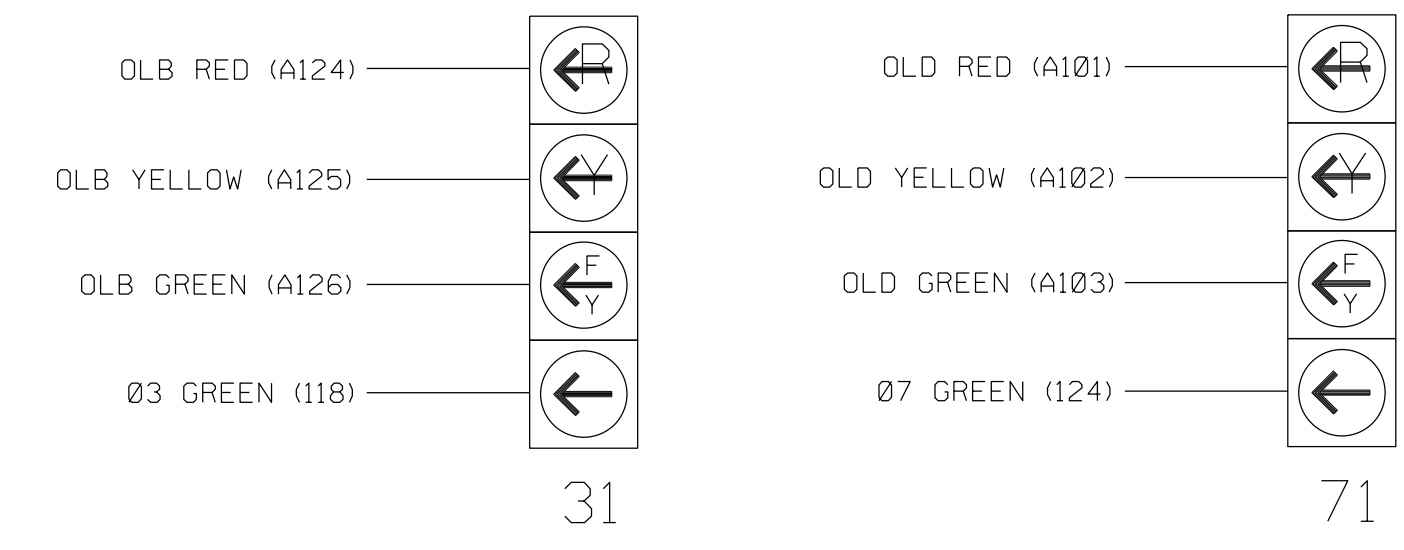

LOAD RESISTOR INSTALLATION DETAIL

(install resistors as shown)

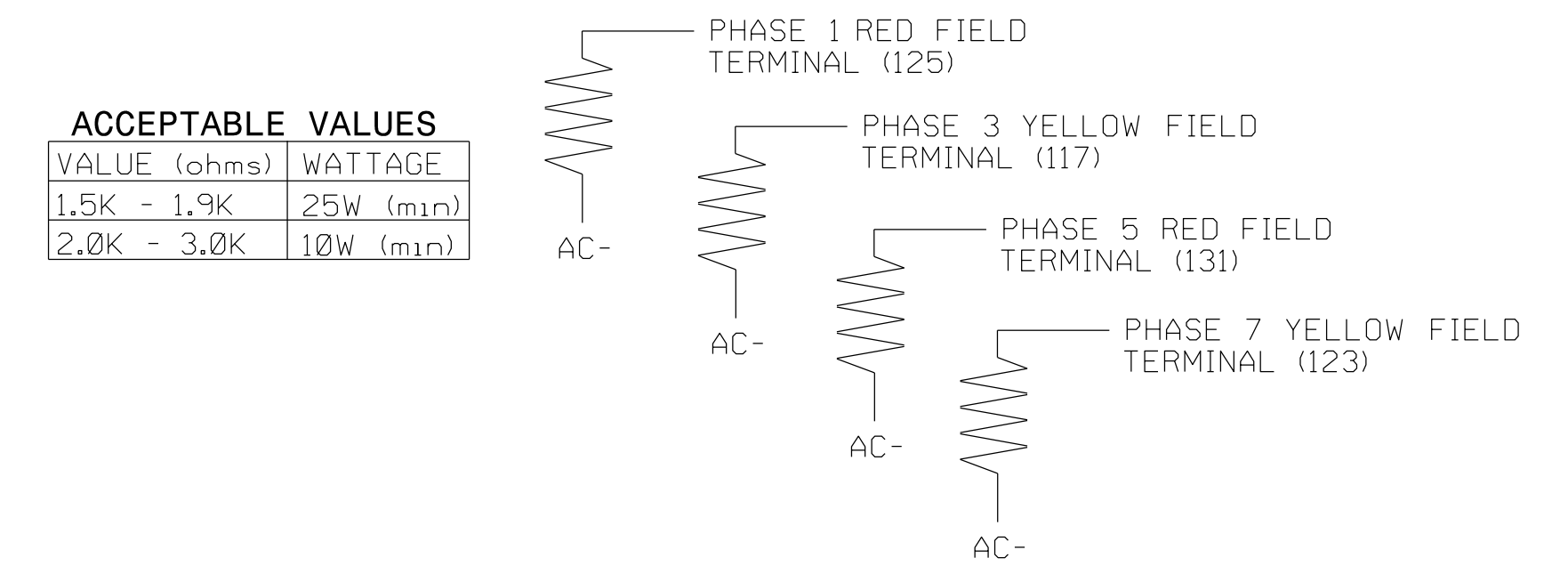

THIS ELECTRICAL DETAIL IS FOR
 THE SIGNAL DESIGN: 01-ØØ05
 DESIGNED: FEBRUARY 2018
 SEALED: 09/20/2018
 REVISED: N/A

Electrical Detail - Sheet 2 of 4

DOCUMENT NOT CONSIDERED FINAL UNLESS ALL SIGNATURES COMPLETED

<p>Plans Prepared By:</p> <p>DRMP, Inc. 8000 Regency Parkway, Suite 175 Cary, NC 27519 NC License No. C-2215 (Ø19) 650-1038</p>	<p>Division 1 Pasquotank County Elizabeth City</p> <p>US 17 Bus. (Road Street) at Main Street</p> <p>PLAN DATE: February 2018 REVIEWED BY: AJ Davis</p> <p>PREPARED BY: DJ White REVIEWED BY: LM Moon</p> <table border="1" style="width: 100%; border-collapse: collapse;"> <thead> <tr> <th>REVISIONS</th> <th>INIT.</th> <th>DATE</th> </tr> </thead> <tbody> <tr> <td> </td> <td> </td> <td> </td> </tr> </tbody> </table>	REVISIONS	INIT.	DATE				<p style="text-align: center;">SEAL</p> <p style="text-align: center;">DocuSigned by: <i>Lisa M. Moon</i> 9/20/2018</p> <p style="text-align: center;">DATE: _____</p> <p style="text-align: center;">SIG. INVENTORY NO. 01-0005</p>
REVISIONS	INIT.	DATE						

20-SEP-2018 18:51
 R:\415942\451\001\5\K051\001\1\mg01-0005-20180821.e.dgn
 Incon AT CAR-LMCDN1-W7

ECONOLITE ASC/3-2070 EMERGENCY VEHICLE PREEMPT PROGRAMMING DETAIL

(program controller as shown)

- 1. From Main Menu select **4. PREEMPTOR/TSP**
- 2. From PREEMPTOR/TSP/SCP Submenu select **1. PREEMPT PLAN 1-10**

Place cursor in [] next to Preempt Plan and press 3. Then press the right cursor arrow and toggle the controller to YES. Next cursor down. This will select Emergency Vehicle Preempt #3.

```

PREEMPT PLAN [ 3]  ENABLE....YES
VEH/PED 1 2 3 4 5 6 7 8 9 0 1 2 3 4 5 6
OVERLAP A B C D E F G H I J K L M N O P
TRKCLR V . . . . .
TRKCLR O . . . . .
ENA TRL . . . . .
DWEL VEH X . . . . X . . . . .
DWEL PED . . . . .
DWEL OLP . . . . .
CYC VEH . . . . .
CYC PED . . . . .
CYC OLP . . . . .
EXIT PH . X . . . X . . . . .
EXIT CAL . . . . .
SP FUNC . . . . .

```

```

ENABLE... YESIPMT OVRIDE..IINTERLOCK. NO
DET LOCK... XIDELAY.. 0IINHIBIT... 0
OVERIDE FL. .IDURATION 0ICLR-GRN... NO
TERM OLP. NOIPC>YEL YESITERM PH NO
PED DARK.. NOITC RESRV NOIDWELL FL OFF
LINK PMT....0IX FLCOLR REDIEEXIT OPT. OFF
X TMG PLN...0IRE-SERV.. 0IFLT TYPE.HARD
FREE DUR PMTIR1 NOIR2 NOIR3 NOIR4 NO
--TIMING-----WALKIPED CLIMN GRI YELI RED
ENTRANCE TM. 255I 255I 1125.5125.5
-----MIN GRIEXT GRIMX GRI YELI RED
TRACK CLEAR 0I 0I 0125.5125.5
-----MIN DLIPMTEXTIMX TMI YELI RED
DWL/CYC-EXIT 7I 2.0I 120125.5125.5
PMT ACTIVE OUT..ON PMT ACT DWELL...NO
OTHER - PRI PMT.OFF NON-PRI PMT....OFF
INH EXT TIME... 0.0 PED PR RETURN...OFF
PRIORITY RETURN.OFF QUEUE DELAY.... OFF
COND DELAY.....OFF
PHASES 1 2 3 4 5 6 7 8
PR RTN% 0 0 0 0 0 0 0 0
PHASES 9 10 11 12 13 14 15 16
PR RTN% 0 0 0 0 0 0 0 0

```

Place cursor in [] next to Preempt Plan and press 4. Then press the right cursor arrow and toggle the controller to YES. Next cursor down. This will select Emergency Vehicle Preempt #4.

```

PREEMPT PLAN [ 4]  ENABLE....YES
VEH/PED 1 2 3 4 5 6 7 8 9 0 1 2 3 4 5 6
OVERLAP A B C D E F G H I J K L M N O P
TRKCLR V . . . . .
TRKCLR O . . . . .
ENA TRL . . . . .
DWEL VEH . X . . . X . . . . .
DWEL PED . . . . .
DWEL OLP . . . . .
CYC VEH . . . . .
CYC PED . . . . .
CYC OLP . . . . .
EXIT PH . X . . . X . . . . .
EXIT CAL . . . . .
SP FUNC . . . . .

```

```

ENABLE... YESIPMT OVRIDE..IINTERLOCK. NO
DET LOCK... XIDELAY.. 0IINHIBIT... 0
OVERIDE FL. .IDURATION 0ICLR-GRN... NO
TERM OLP. NOIPC>YEL YESITERM PH NO
PED DARK.. NOITC RESRV NOIDWELL FL OFF
LINK PMT....0IX FLCOLR REDIEEXIT OPT. OFF
X TMG PLN...0IRE-SERV.. 0IFLT TYPE.HARD
FREE DUR PMTIR1 NOIR2 NOIR3 NOIR4 NO
--TIMING-----WALKIPED CLIMN GRI YELI RED
ENTRANCE TM. 255I 255I 1125.5125.5
-----MIN GRIEXT GRIMX GRI YELI RED
TRACK CLEAR 0I 0I 0125.5125.5
-----MIN DLIPMTEXTIMX TMI YELI RED
DWL/CYC-EXIT 7I 2.0I 120125.5125.5
PMT ACTIVE OUT..ON PMT ACT DWELL...NO
OTHER - PRI PMT.OFF NON-PRI PMT....OFF
INH EXT TIME... 0.0 PED PR RETURN...OFF
PRIORITY RETURN.OFF QUEUE DELAY.... OFF
COND DELAY.....OFF
PHASES 1 2 3 4 5 6 7 8
PR RTN% 0 0 0 0 0 0 0 0
PHASES 9 10 11 12 13 14 15 16
PR RTN% 0 0 0 0 0 0 0 0

```

Place cursor in [] next to Preempt Plan and press 5. Then press the right cursor arrow and toggle the controller to YES. Next cursor down. This will select Emergency Vehicle Preempt #5.

```

PREEMPT PLAN [ 5]  ENABLE....YES
VEH/PED 1 2 3 4 5 6 7 8 9 0 1 2 3 4 5 6
OVERLAP A B C D E F G H I J K L M N O P
TRKCLR V . . . . .
TRKCLR O . . . . .
ENA TRL . . . . .
DWEL VEH . . X . . . . X . . . . .
DWEL PED . . . . .
DWEL OLP .F1 .F1 . . . . .
CYC VEH . . . . .
CYC PED . . . . .
CYC OLP . . . . .
EXIT PH . . . X . . . X . . . . .
EXIT CAL . . . . .
SP FUNC . . . . .

```

```

ENABLE... YESIPMT OVRIDE..IINTERLOCK. NO
DET LOCK... XIDELAY.. 0IINHIBIT... 0
OVERIDE FL. .IDURATION 0ICLR-GRN... NO
TERM OLP. NOIPC>YEL YESITERM PH NO
PED DARK.. NOITC RESRV NOIDWELL FL OFF
LINK PMT....0IX FLCOLR REDIEEXIT OPT. OFF
X TMG PLN...0IRE-SERV.. 0IFLT TYPE.HARD
FREE DUR PMTIR1 NOIR2 NOIR3 NOIR4 NO
--TIMING-----WALKIPED CLIMN GRI YELI RED
ENTRANCE TM. 255I 255I 1125.5125.5
-----MIN GRIEXT GRIMX GRI YELI RED
TRACK CLEAR 0I 0I 0125.5125.5
-----MIN DLIPMTEXTIMX TMI YELI RED
DWL/CYC-EXIT 7I 2.0I 120125.5125.5
PMT ACTIVE OUT..ON PMT ACT DWELL...NO
OTHER - PRI PMT.OFF NON-PRI PMT....OFF
INH EXT TIME... 0.0 PED PR RETURN...OFF
PRIORITY RETURN.OFF QUEUE DELAY.... OFF
COND DELAY.....OFF
PHASES 1 2 3 4 5 6 7 8
PR RTN% 0 0 0 0 0 0 0 0
PHASES 9 10 11 12 13 14 15 16
PR RTN% 0 0 0 0 0 0 0 0

```

Place cursor in [] next to Preempt Plan and press 6. Then press the right cursor arrow and toggle the controller to YES. Next cursor down. This will select Emergency Vehicle Preempt #6.

```

PREEMPT PLAN [ 6]  ENABLE....YES
VEH/PED 1 2 3 4 5 6 7 8 9 0 1 2 3 4 5 6
OVERLAP A B C D E F G H I J K L M N O P
TRKCLR V . . . . .
TRKCLR O . . . . .
ENA TRL . . . . .
DWEL VEH . . . . X . . . . X . . . . .
DWEL PED . . . . .
DWEL OLP .F1 .F1 . . . . .
CYC VEH . . . . .
CYC PED . . . . .
CYC OLP . . . . .
EXIT PH . . . X . . . X . . . . .
EXIT CAL . . . . .
SP FUNC . . . . .

```

```

ENABLE... YESIPMT OVRIDE..IINTERLOCK. NO
DET LOCK... XIDELAY.. 0IINHIBIT... 0
OVERIDE FL. .IDURATION 0ICLR-GRN... NO
TERM OLP. NOIPC>YEL YESITERM PH NO
PED DARK.. NOITC RESRV NOIDWELL FL OFF
LINK PMT....0IX FLCOLR REDIEEXIT OPT. OFF
X TMG PLN...0IRE-SERV.. 0IFLT TYPE.HARD
FREE DUR PMTIR1 NOIR2 NOIR3 NOIR4 NO
--TIMING-----WALKIPED CLIMN GRI YELI RED
ENTRANCE TM. 255I 255I 1125.5125.5
-----MIN GRIEXT GRIMX GRI YELI RED
TRACK CLEAR 0I 0I 0125.5125.5
-----MIN DLIPMTEXTIMX TMI YELI RED
DWL/CYC-EXIT 7I 2.0I 120125.5125.5
PMT ACTIVE OUT..ON PMT ACT DWELL...NO
OTHER - PRI PMT.OFF NON-PRI PMT....OFF
INH EXT TIME... 0.0 PED PR RETURN...OFF
PRIORITY RETURN.OFF QUEUE DELAY.... OFF
COND DELAY.....OFF
PHASES 1 2 3 4 5 6 7 8
PR RTN% 0 0 0 0 0 0 0 0
PHASES 9 10 11 12 13 14 15 16
PR RTN% 0 0 0 0 0 0 0 0

```

20-SEP-2018 18:51 R:\415942\51\001\415942.dgn AT CAR-LMD\DMT-WT

THIS ELECTRICAL DETAIL IS FOR THE SIGNAL DESIGN: 01-0005 DESIGNED: FEBRUARY 2018 SEALED: 09/20/2018 REVISED: N/A



Electrical Detail - Sheet 3 of 4

ELECTRICAL AND PROGRAMMING DETAILS FOR:

Prepared for the Offices of:

750 N. Greenfield Pkwy, Garner, NC 27529

US 17 Bus. (Road Street) at Main Street	
Division 1 Pasquotank County Elizabeth City	PLAN DATE: February 2018
PREPARED BY: DJ White	REVIEWED BY: AJ Davis
REVISIONS	INIT. DATE

DOCUMENT NOT CONSIDERED FINAL UNLESS ALL SIGNATURES COMPLETED

SEAL

DocuSigned by: Lisa M. Moon 9/20/2018

SIG. INVENTORY NO. 01-0005

ECONOLITE ASC/3-2070 LOGIC PROCESSOR PROGRAMMING DETAIL FOR PREEMPT ONLY PHASE OMIT

(program controller as shown)

The following logic processor configuration holds the FYA's on signal heads 31 and 71 red for the duration of the delayed green time (leading ped interval) when serving a ped call on the opposing through phase.

- From Main Menu select **1. CONFIGURATION**
- From CONFIGURATION Submenu select **8. LOGIC PROCESSOR**
- From the LOGIC PROCESSOR Submenu select **2. LOGIC STATEMENTS**

ENTER A "1" IN THE LP# FIELD, PRESS 'ENTER', AND PROGRAM AS SHOWN.

```

LP#: 3 COPY FROM: 3 ACTIVE: M (T/F)
IF PMT PREEMPT ACTIVE 3 IS OFF

THEN CTR OMIT PHASE 1 ON

ELSE

```

LOGIC FOR OMITTING PHASE 1 AT STARTUP AND/OR WHEN NOT IN PREEMPT

ENTER A "2" IN THE LP# FIELD, PRESS 'ENTER', AND PROGRAM AS SHOWN.

```

LP#: 4 COPY FROM: 4 ACTIVE: M (T/F)
IF PMT PREEMPT ACTIVE 4 IS OFF

THEN CTR OMIT PHASE 5 ON

ELSE

```

LOGIC FOR OMITTING PHASE 3 AT STARTUP AND/OR WHEN NOT IN PREEMPT

ENTER A "3" IN THE LP# FIELD, PRESS 'ENTER', AND PROGRAM AS SHOWN.

```

LP#: 5 COPY FROM: 5 ACTIVE: M (T/F)
IF PMT PREEMPT ACTIVE 5 IS OFF

THEN CTR OMIT PHASE 3 ON

ELSE

```

LOGIC FOR OMITTING PHASE 5 AT STARTUP AND/OR WHEN NOT IN PREEMPT

ENTER A "4" IN THE LP# FIELD, PRESS 'ENTER', AND PROGRAM AS SHOWN.

```

LP#: 6 COPY FROM: 6 ACTIVE: M (T/F)
IF PMT PREEMPT ACTIVE 6 IS OFF

THEN CTR OMIT PHASE 7 ON

ELSE

```

LOGIC FOR OMITTING PHASE 7 AT STARTUP AND/OR WHEN NOT IN PREEMPT

- From the LOGIC PROCESSOR Submenu select **1. LOGIC STATEMENT CONTROL**

ENABLE LOGIC PROCESSOR STATEMENTS 1-6 BY POSITIONING THE CURSOR OVER THE FIELDS SHOWN BELOW AND USING THE TOGGLE KEY TO ENABLE THEM .

LOGIC STATEMENT CONTROL	1	2	3	4	5	6	7	8	9	0	1	2	3	4	5	6
LP 1-15	E	E	E	E
LP 16-30
LP 31-45
LP 46-60
LP 61-75
LP 76-90

END PROGRAMMING

ECONOLITE ASC/3-2070 PREEMPT FILTERING PROGRAMMING DETAIL

(program controller as shown)

- From Main Menu select **4. PREEMPTOR/TSP**
- From PREEMPT/TSP/SCP Submenu select **2. ENABLE PREEMPT FILTERING & TSP/SCP**

ENABLE PREEMPT FILTERING & TSP/SCP	SOLID	PULSING
INPUT 1	...BYPASSED..	...BYPASSED..
2	...BYPASSED..	...BYPASSED..
3	..PREEMPT	3. ...BYPASSED..
4	..PREEMPT	4. ...BYPASSED..
5	..PREEMPT	5. ...BYPASSED..
6	..PREEMPT	6. ...BYPASSED..
7	..BYPASSED..	...BYPASSED..
8	...BYPASSED..	...BYPASSED..
9	...BYPASSED..	...BYPASSED..
10	...BYPASSED..	...BYPASSED..

THIS ELECTRICAL DETAIL IS FOR THE SIGNAL DESIGN: 01-0005 DESIGNED: FEBRUARY 2018 SEALED: 09/20/2018 REVISED: N/A

DOCUMENT NOT CONSIDERED FINAL UNLESS ALL SIGNATURES COMPLETED

ELECTRICAL AND PROGRAMMING DETAILS FOR:

Prepared for the Offices of:

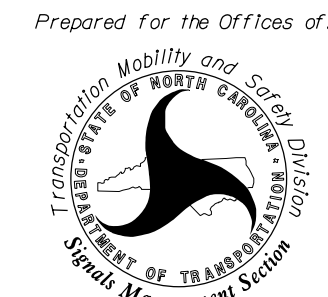

Plans Prepared By:



DRMP, Inc.
8000 Regency Parkway, Suite 175
Cary, NC 27519
NC License No. C-2215 (019) 650-1038

US 17 Bus. (Road Street) at Main Street	
Division 1 Pasquotank County	Elizabeth City
PLAN DATE: February 2018	REVIEWED BY: AJ Davis
PREPARED BY: DJ White	REVIEWED BY: LM Moon
REVISIONS	INIT. DATE

SEAL



DocuSigned by: Lisa M. Moon 9/20/2018

SIG. INVENTORY NO. 01-0005

PHASING DIAGRAM

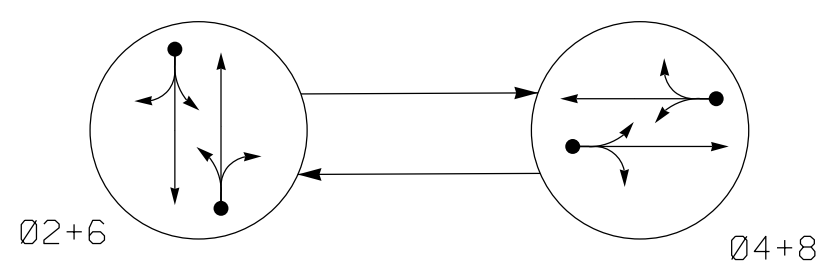

EV PREEMPT PHASES

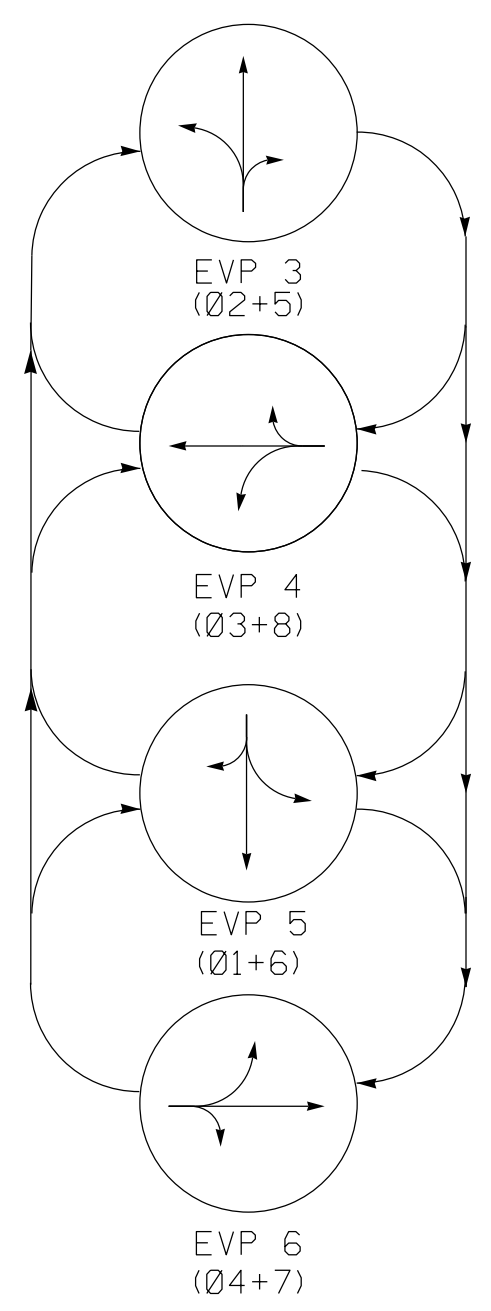

PHASING DIAGRAM DETECTION LEGEND

- DETECTED MOVEMENT
- UNDETECTED MOVEMENT (OVERLAP)
- UNSIGNALIZED MOVEMENT
- PEDESTRIAN MOVEMENT

ASC/3 EV PREEMPT				
FUNCTION	PRE 3	PRE 4	PRE 5	PRE 6
Exit Phase(s)	2,6	2,6	2,6	2,6
Preempt Override	OFF	OFF	OFF	OFF
Delay Time	0	0	0	0
Ped Clear Through Yellow	N	N	N	N
Terminate Phases	N	N	N	N
Entrance Walk	255*	255*	255*	255*
Entrance Ped Clear	255*	255*	255*	255*
Entrance Min Green	1	1	1	1
Entrance Yellow Change	25.5*	25.5*	25.5*	25.5*
Entrance Red Clear	25.5*	25.5*	25.5*	25.5*
Minimum Dwell Time	7	7	7	7
Preempt Input Extension Time	2	2	2	2
Preempt Max Time	120	120	120	120
Exit Yellow Change	25.5*	25.5*	25.5*	25.5*
Exit Red Clear	25.5*	25.5*	25.5*	25.5*

* Allows normal phase times to be used.

SIGNAL FACE I.D.

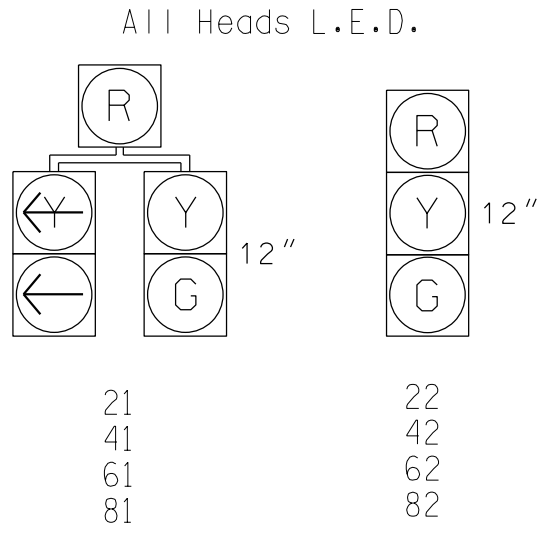

ASC/3 DETECTOR INSTALLATION CHART												
DETECTOR				PROGRAMMING								
LOOP	SIZE (FT)	DISTANCE FROM STOPBAR (FT)	URNS	NEW LOOP	PHASE	CALLING	EXTEND TIME	DELAY TIME	USE ADDED INITIAL	TYPE	LOOP SYSTEM	NEW CARD
2A	6X40	0	2-4-2	X	2	Yes	-	-	-	S	-	X
4A	6X40	0	2-4-2	X	4	Yes	-	-	-	S	-	X
6A	6X40	0	2-4-2	X	6	Yes	-	-	-	S	-	X
8A	6X40	0	2-4-2	X	8	Yes	-	5	-	S	-	X

TABLE OF OPERATION

SIGNAL FACE	PHASE						FLASH
	Ø 2 + 6	Ø 4 + 8	EVP 3	EVP 4	EVP 5	EVP 6	
21	G	R	G	R	R	Y	
22	G	R	G	R	R	Y	
41	R	G	R	R	R	G	
42	R	G	R	R	R	G	
61	G	R	R	R	G	R	
62	G	R	R	R	G	R	
81	R	G	R	G	R	R	
82	R	G	R	G	R	R	

2 Phase Fully Actuated W/ EV Preemption (Elizabeth City Signal System)

NOTES

- Refer to "Roadway Standard Drawings NCDOT" dated January 2018 and "Standard Specifications for Roads and Structures" dated January 2018.
- Do not program signal for late night flashing operation unless otherwise directed by the Engineer.
- Set all detector units to presence mode.
- Locate new cabinet so as not to obstruct sight distance of vehicles turning right on red.
- Pavement markings are existing. Repaint stop bars, crosswalks and 50' of double yellow lane lines in same locations on eastbound and westbound approaches.
- Relocate existing optical detector system to integrate into new controller cabinet and signal installation.
- This intersection features an optical preemption system. Shown location of optical detectors are conceptual only.
- Optical detector 10 calls EVP3; Optical detector 20 calls EVP5; Optical detector 30 calls EVP6; Optical detector 40 calls EVP4.
- Maximum times shown in timing chart are for free-run operation only. Coordinated signal system timing values supersede these values.

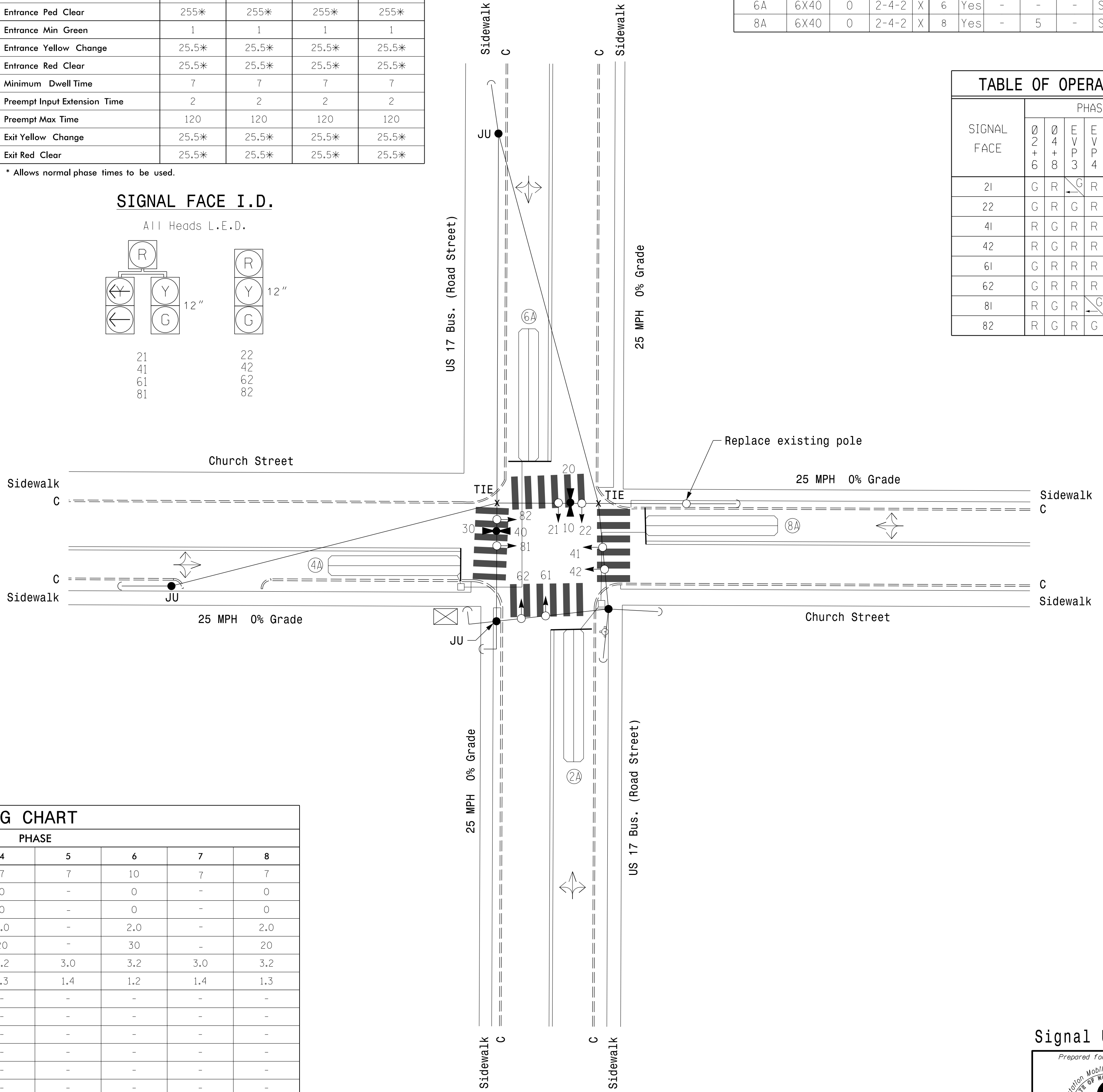

ASC/3 TIMING CHART

FEATURE	PHASE							
	1	2	3	4	5	6	7	8
Min Green *	7	10	7	7	7	10	7	7
Walk *	-	0	-	0	-	0	-	0
Ped Clear	-	0	-	0	-	0	-	0
Veh. Extension *	-	2.0	-	2.0	-	2.0	-	2.0
Max 1 *	-	30	-	20	-	30	-	20
Yellow	3.0	3.2	3.0	3.2	3.0	3.2	3.0	3.2
Red Clear	1.4	1.2	1.2	1.3	1.4	1.2	1.4	1.3
Actuations B4 Add *	-	-	-	-	-	-	-	-
Seconds / Actuation *	-	-	-	-	-	-	-	-
Max Initial *	-	-	-	-	-	-	-	-
Time Before Reduction *	-	-	-	-	-	-	-	-
Time To Reduce *	-	-	-	-	-	-	-	-
Minimum Gap	-	-	-	-	-	-	-	-
Locking Detector	-	X	-	-	-	X	-	-
Recall Position	-	VEH. RECALL	-	-	-	VEH. RECALL	-	-
Dual Entry	-	-	-	X	-	-	-	X
Simultaneous Gap	X	X	X	X	X	X	X	X

* These values may be field adjusted. Do not adjust Min Green and Extension times for phases 2 and 6 lower than what is shown. Min Green for all other phases should not be lower than 4 seconds.

LEGEND

- | PROPOSED | EXISTING |
|--|--|
| ○ Traffic Signal Head | ● Traffic Signal Head |
| ○ Modified Signal Head | N/A |
| — Sign | — Sign |
| ○ Pedestrian Signal Head With Push Button & Sign | ○ Pedestrian Signal Head With Push Button & Sign |
| — Signal Pole with Guy | — Signal Pole with Guy |
| — Signal Pole with Sidewalk Guy | — Signal Pole with Sidewalk Guy |
| □ Inductive Loop Detector | □ Inductive Loop Detector |
| □ Controller & Cabinet | □ Controller & Cabinet |
| □ Junction Box | □ Junction Box |
| — 2-in Underground Conduit | — 2-in Underground Conduit |
| N/A Right of Way | — Right of Way |
| N/A Directional Arrow | → Directional Arrow |
| N/A Fire Hydrant | ⊕ Fire Hydrant |
| ○ Optical Detector | ⊕ Optical Detector |

Signal Upgrade

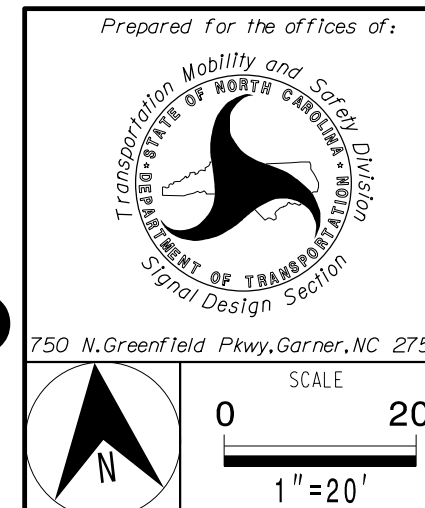

US 17 Bus. (Road Street) at Church Street

Division 1 Pasquotank County Elizabeth City

PLAN DATE: February 2018 REVIEWED BY: AJ Davis

PREPARED BY: JA Le REVIEWED BY: LM Moon

REVISIONS	INIT.	DATE

DOCUMENT NOT CONSIDERED FINAL UNLESS ALL SIGNATURES COMPLETED

SEAL

STATE OF NORTH CAROLINA PROFESSIONAL ENGINEER

SEAL 022516

LISA M. MOON

DocuSigned by: Lisa M. Moon 8/21/2018

SIG. INVENTORY NO. 01-0006

21-AUG-2018 16:54 R:\05942\51001\0005\0005\Signal\001-0006.dgn lmoon AT CAR-LMOON-WT

ECONOLITE ASC/3-2070 EMERGENCY VEHICLE PREEMPT PROGRAMMING DETAIL

(program controller as shown)

- 1. From Main Menu select 4. PREEMPTOR/TSP
- 2. From PREEMPTOR/TSP/SCP Submenu select 1. PREEMPT PLAN 1-10

Place cursor in [] next to Preempt Plan and press 3. Then press the right cursor arrow and toggle the controller to YES. Next cursor down. This will select Emergency Vehicle Preempt #3.

```

PREEMPT PLAN [ 3]  ENABLE....YES
VEH/PED 1 2 3 4 5 6 7 8 9 0 1 2 3 4 5 6
OVERLAP A B C D E F G H I J K L M N O P
TRKCLR V . . . . .
TRKCLR O . . . . .
ENA TRL . . . . .
DWEL VEH . X . . X . . . . .
DWEL PED . . . . .
DWEL OLP . . . . .
CYC VEH . . . . .
CYC PED . . . . .
CYC OLP . . . . .
EXIT PH . X . . . X . . . . .
EXIT CAL . . . . .
SP FUNC . . . . .

```

```

ENABLE... YESIPMT OVRIDE..IINTERLOCK. NO
DET LOCK... XIDELAY.. 0IINHIBIT... 0
OVERIDE FL. .IDURATION 0ICLR-GRN... NO
TERM OLP. NOIPC>YEL NOITERM PH NO
PED DARK.. NOITC RESRV NOIDWELL FL OFF
LINK PMT....0IX FLCOLR REDIEEXIT OPT. OFF
X TMG PLN...0IRE-SERV.. 0IFLT TYPE.HARD
FREE DUR PMTIR1 NOIR2 NOIR3 NOIR4 NO
--TIMING-----WALKIPED CLIMN GRI YELI RED
ENTRANCE TM. 255I 255I 1125.5125.5
-----MIN GRIEXT GRIMX GRI YELI RED
TRACK CLEAR 0I 0I 0I25.5125.5
-----MIN DLIPMTEXTIMX TMI YELI RED
DWL/CYC-EXIT 7I 2.0I 120I25.5125.5
PMT ACTIVE OUT..ON PMT ACT DWELL...NO
OTHER - PRI PMT.OFF NON-PRI PMT....OFF
INH EXT TIME... 0.0 PED PR RETURN...OFF
PRIORITY RETURN.OFF QUEUE DELAY.... OFF
COND DELAY.....OFF
PHASES 1 2 3 4 5 6 7 8
PR RTN% 0 0 0 0 0 0 0 0
PHASES 9 10 11 12 13 14 15 16
PR RTN% 0 0 0 0 0 0 0 0

```

Place cursor in [] next to Preempt Plan and press 4. Then press the right cursor arrow and toggle the controller to YES. Next cursor down. This will select Emergency Vehicle Preempt #4.

```

PREEMPT PLAN [ 4]  ENABLE....YES
VEH/PED 1 2 3 4 5 6 7 8 9 0 1 2 3 4 5 6
OVERLAP A B C D E F G H I J K L M N O P
TRKCLR V . . . . .
TRKCLR O . . . . .
ENA TRL . . . . .
DWEL VEH . . X . . . . X . . . . .
DWEL PED . . . . .
DWEL OLP . . . . .
CYC VEH . . . . .
CYC PED . . . . .
CYC OLP . . . . .
EXIT PH . X . . . X . . . . .
EXIT CAL . . . . .
SP FUNC . . . . .

```

```

ENABLE... YESIPMT OVRIDE..IINTERLOCK. NO
DET LOCK... XIDELAY.. 0IINHIBIT... 0
OVERIDE FL. .IDURATION 0ICLR-GRN... NO
TERM OLP. NOIPC>YEL NOITERM PH NO
PED DARK.. NOITC RESRV NOIDWELL FL OFF
LINK PMT....0IX FLCOLR REDIEEXIT OPT. OFF
X TMG PLN...0IRE-SERV.. 0IFLT TYPE.HARD
FREE DUR PMTIR1 NOIR2 NOIR3 NOIR4 NO
--TIMING-----WALKIPED CLIMN GRI YELI RED
ENTRANCE TM. 255I 255I 1125.5125.5
-----MIN GRIEXT GRIMX GRI YELI RED
TRACK CLEAR 0I 0I 0I25.5125.5
-----MIN DLIPMTEXTIMX TMI YELI RED
DWL/CYC-EXIT 7I 2.0I 120I25.5125.5
PMT ACTIVE OUT..ON PMT ACT DWELL...NO
OTHER - PRI PMT.OFF NON-PRI PMT....OFF
INH EXT TIME... 0.0 PED PR RETURN...OFF
PRIORITY RETURN.OFF QUEUE DELAY.... OFF
COND DELAY.....OFF
PHASES 1 2 3 4 5 6 7 8
PR RTN% 0 0 0 0 0 0 0 0
PHASES 9 10 11 12 13 14 15 16
PR RTN% 0 0 0 0 0 0 0 0

```

Place cursor in [] next to Preempt Plan and press 5. Then press the right cursor arrow and toggle the controller to YES. Next cursor down. This will select Emergency Vehicle Preempt #5.

```

PREEMPT PLAN [ 5]  ENABLE....YES
VEH/PED 1 2 3 4 5 6 7 8 9 0 1 2 3 4 5 6
OVERLAP A B C D E F G H I J K L M N O P
TRKCLR V . . . . .
TRKCLR O . . . . .
ENA TRL . . . . .
DWEL VEH X . . . . X . . . . .
DWEL PED . . . . .
DWEL OLP . . . . .
CYC VEH . . . . .
CYC PED . . . . .
CYC OLP . . . . .
EXIT PH . X . . . X . . . . .
EXIT CAL . . . . .
SP FUNC . . . . .

```

```

ENABLE... YESIPMT OVRIDE..IINTERLOCK. NO
DET LOCK... XIDELAY.. 0IINHIBIT... 0
OVERIDE FL. .IDURATION 0ICLR-GRN... NO
TERM OLP. NOIPC>YEL NOITERM PH NO
PED DARK.. NOITC RESRV NOIDWELL FL OFF
LINK PMT....0IX FLCOLR REDIEEXIT OPT. OFF
X TMG PLN...0IRE-SERV.. 0IFLT TYPE.HARD
FREE DUR PMTIR1 NOIR2 NOIR3 NOIR4 NO
--TIMING-----WALKIPED CLIMN GRI YELI RED
ENTRANCE TM. 255I 255I 1125.5125.5
-----MIN GRIEXT GRIMX GRI YELI RED
TRACK CLEAR 0I 0I 0I25.5125.5
-----MIN DLIPMTEXTIMX TMI YELI RED
DWL/CYC-EXIT 7I 2.0I 120I25.5125.5
PMT ACTIVE OUT..ON PMT ACT DWELL...NO
OTHER - PRI PMT.OFF NON-PRI PMT....OFF
INH EXT TIME... 0.0 PED PR RETURN...OFF
PRIORITY RETURN.OFF QUEUE DELAY.... OFF
COND DELAY.....OFF
PHASES 1 2 3 4 5 6 7 8
PR RTN% 0 0 0 0 0 0 0 0
PHASES 9 10 11 12 13 14 15 16
PR RTN% 0 0 0 0 0 0 0 0

```

Place cursor in [] next to Preempt Plan and press 6. Then press the right cursor arrow and toggle the controller to YES. Next cursor down. This will select Emergency Vehicle Preempt #6.

```

PREEMPT PLAN [ 6]  ENABLE....YES
VEH/PED 1 2 3 4 5 6 7 8 9 0 1 2 3 4 5 6
OVERLAP A B C D E F G H I J K L M N O P
TRKCLR V . . . . .
TRKCLR O . . . . .
ENA TRL . . . . .
DWEL VEH . . . X . . X . . . . .
DWEL PED . . . . .
DWEL OLP . . . . .
CYC VEH . . . . .
CYC PED . . . . .
CYC OLP . . . . .
EXIT PH . X . . . X . . . . .
EXIT CAL . . . . .
SP FUNC . . . . .

```

```

ENABLE... YESIPMT OVRIDE..IINTERLOCK. NO
DET LOCK... XIDELAY.. 0IINHIBIT... 0
OVERIDE FL. .IDURATION 0ICLR-GRN... NO
TERM OLP. NOIPC>YEL NOITERM PH NO
PED DARK.. NOITC RESRV NOIDWELL FL OFF
LINK PMT....0IX FLCOLR REDIEEXIT OPT. OFF
X TMG PLN...0IRE-SERV.. 0IFLT TYPE.HARD
FREE DUR PMTIR1 NOIR2 NOIR3 NOIR4 NO
--TIMING-----WALKIPED CLIMN GRI YELI RED
ENTRANCE TM. 255I 255I 1125.5125.5
-----MIN GRIEXT GRIMX GRI YELI RED
TRACK CLEAR 0I 0I 0I25.5125.5
-----MIN DLIPMTEXTIMX TMI YELI RED
DWL/CYC-EXIT 7I 2.0I 120I25.5125.5
PMT ACTIVE OUT..ON PMT ACT DWELL...NO
OTHER - PRI PMT.OFF NON-PRI PMT....OFF
INH EXT TIME... 0.0 PED PR RETURN...OFF
PRIORITY RETURN.OFF QUEUE DELAY.... OFF
COND DELAY.....OFF
PHASES 1 2 3 4 5 6 7 8
PR RTN% 0 0 0 0 0 0 0 0
PHASES 9 10 11 12 13 14 15 16
PR RTN% 0 0 0 0 0 0 0 0

```

20-SEP-2018 19:49 R:\415942\51and\shades\gnw\1r\mg401-0006-20180821.e.dgn lmoon AT CAR-LMOON-WT

THIS ELECTRICAL DETAIL IS FOR THE SIGNAL DESIGN: 01-0006 DESIGNED: FEBRUARY 2018 SEALED: 08/21/2018 REVISED: N/A

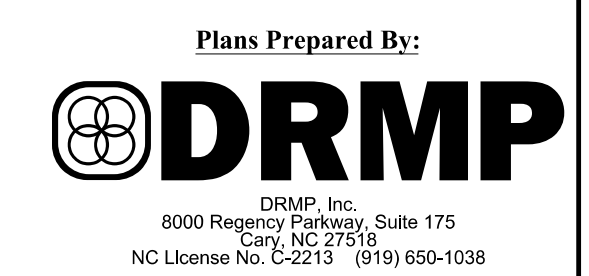

Electrical Detail - Sheet 2 of 3

DOCUMENT NOT CONSIDERED FINAL UNLESS ALL SIGNATURES COMPLETED

ELECTRICAL AND PROGRAMMING DETAILS FOR:

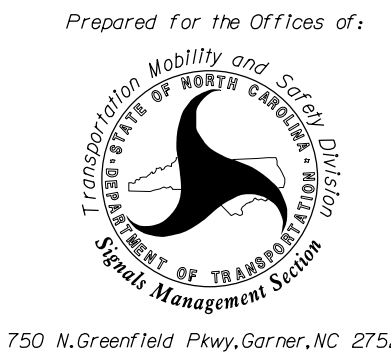
Prepared for the Offices of:

US 17 Bus. (Road Street) at Church Street

Division 1 Pasquotank County Elizabeth City

PLAN DATE: February 2018 REVIEWED BY: AJ Davis

PREPARED BY: DJ White REVIEWED BY: LM Moon

REVISIONS	INIT.	DATE

DocuSigned by: Lisa M. Moon 9/20/2018
 SEAL 022516
 LISA M. MOON
 ENGINEER
 STATE OF NORTH CAROLINA
 SIG. INVENTORY NO. 01-0006

ECONOLITE ASC/3-2070 LOGIC PROCESSOR PROGRAMMING DETAIL FOR PREEMPT ONLY PHASE OMIT

(program controller as shown)

The following logic processor configuration holds the FYA's on signal heads 11, 31, 51, and 71 red for the duration of the delayed green time (leading ped interval) when serving a ped call on the opposing through phase.

1. From Main Menu select 1. CONFIGURATION
2. From CONFIGURATION Submenu select 8. LOGIC PROCESSOR
3. From the LOGIC PROCESSOR Submenu select 2. LOGIC STATEMENTS

ENTER A "1" IN THE LP# FIELD, PRESS 'ENTER', AND PROGRAM AS SHOWN.

LP#:	1	COPY FROM:	1	ACTIVE:	M	(T/F)	
IF	PMT PREEMPT ACTIVE		3	IS		OFF	
THEN	CTR OMIT PHASE		5			ON	
ELSE							

LOGIC FOR OMITTING PHASE 1 AT STARTUP AND/OR WHEN NOT IN PREEMPT

ENTER A "2" IN THE LP# FIELD, PRESS 'ENTER', AND PROGRAM AS SHOWN.

LP#:	2	COPY FROM:	2	ACTIVE:	M	(T/F)	
IF	PMT PREEMPT ACTIVE		4	IS		OFF	
THEN	CTR OMIT PHASE		3			ON	
ELSE							

LOGIC FOR OMITTING PHASE 3 AT STARTUP AND/OR WHEN NOT IN PREEMPT

ENTER A "3" IN THE LP# FIELD, PRESS 'ENTER', AND PROGRAM AS SHOWN.

LP#:	3	COPY FROM:	3	ACTIVE:	M	(T/F)	
IF	PMT PREEMPT ACTIVE		5	IS		OFF	
THEN	CTR OMIT PHASE		1			ON	
ELSE							

LOGIC FOR OMITTING PHASE 5 AT STARTUP AND/OR WHEN NOT IN PREEMPT

ENTER A "4" IN THE LP# FIELD, PRESS 'ENTER', AND PROGRAM AS SHOWN.

LP#:	4	COPY FROM:	4	ACTIVE:	M	(T/F)	
IF	PMT PREEMPT ACTIVE		6	IS		OFF	
THEN	CTR OMIT PHASE		7			ON	
ELSE							

LOGIC FOR OMITTING PHASE 7 AT STARTUP AND/OR WHEN NOT IN PREEMPT

1. From Main Menu select 1. CONFIGURATION
2. From CONFIGURATION Submenu select 8. LOGIC PROCESSOR
3. From the LOGIC PROCESSOR Submenu select 1. LOGIC STATEMENT CONTROL

ENABLE LOGIC PROCESSOR STATEMENTS 1-4 BY POSITIONING THE CURSOR OVER THE FIELDS SHOWN BELOW AND USING THE TOGGLE KEY TO ENABLE THEM .

LOGIC STATEMENT CONTROL	1	2	3	4	5	6	7	8	9	0	1	2	3	4	5	6	
LP 1-15	E	E	E	E
LP 16-30
LP 31-45
LP 46-60
LP 61-75
LP 76-90

END PROGRAMMING

ECONOLITE ASC/3-2070 PREEMPT FILTERING PROGRAMMING DETAIL

(program controller as shown)

1. From Main Menu select 4. PREEMPTOR/TSP
2. From PREEMPT/TSP/SCP Submenu select 2. ENABLE PREEMPT FILTERING & TSP/SCP

ENABLE PREEMPT FILTERING & TSP/SCP	
FILTERED SOLID	PULSING
INPUT 1	...BYPASSED... ..BYPASSED..
2	...BYPASSED... ..BYPASSED..
3	..PREEMPT 3. ...BYPASSED..
4	..PREEMPT 4. ...BYPASSED..
5	..PREEMPT 5. ...BYPASSED..
6	..PREEMPT 6. ...BYPASSED..
7	...BYPASSED... ..BYPASSED..
8	...BYPASSED... ..BYPASSED..
9	...BYPASSED... ..BYPASSED..
10	...BYPASSED... ..BYPASSED..

THIS ELECTRICAL DETAIL IS FOR THE SIGNAL DESIGN: 01-0006
DESIGNED: FEBRUARY 2018
SEALED: 08/21/2018
REVISED: N/A

20-SEP-2018 10:49
R:\15942\51\001\5\K\ess\gn\w\1\1\mg\01-0006-20180821.e.dgn
lmoon AT CAR-LMOON-W7

Electrical Detail - Sheet 3 of 3

**DOCUMENT NOT CONSIDERED FINAL
UNLESS ALL SIGNATURES COMPLETED**

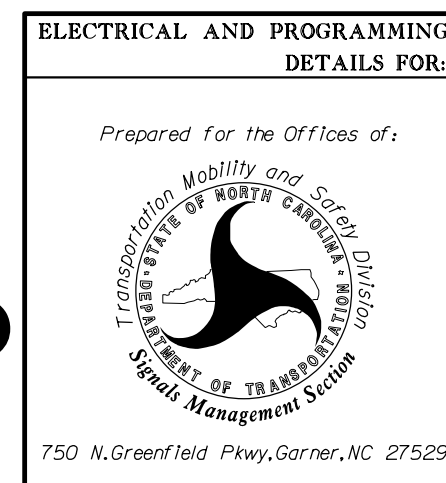

US 17 Bus. (Road Street) at Church Street	
Division 1 Pasquotank County Elizabeth City	
PLAN DATE: February 2018	REVIEWED BY: AJ Davis
PREPARED BY: DJ White	REVIEWED BY: LM Moon
REVISIONS	INIT. DATE

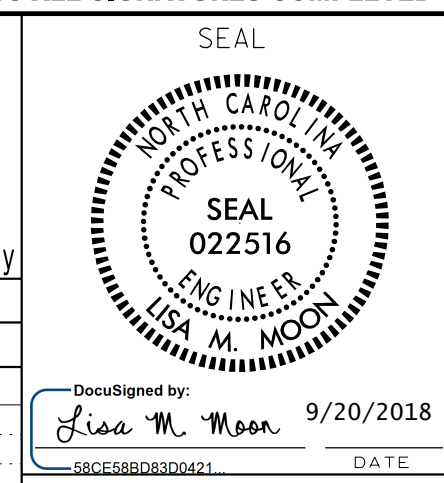

SIG. INVENTORY NO. 01-0006

PHASING DIAGRAM

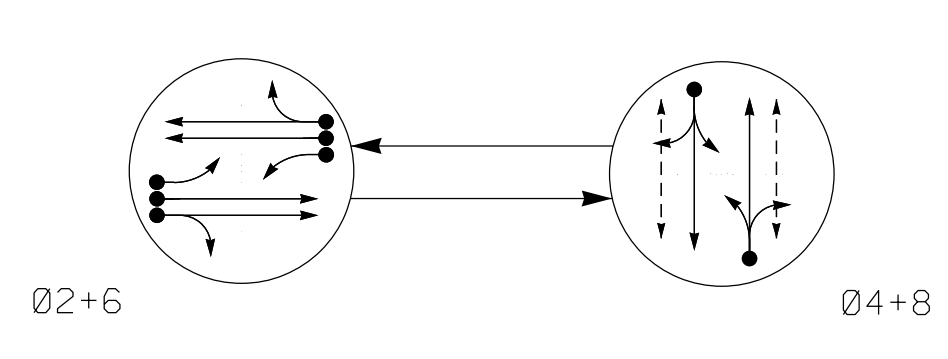

EV PREEMPT PHASES

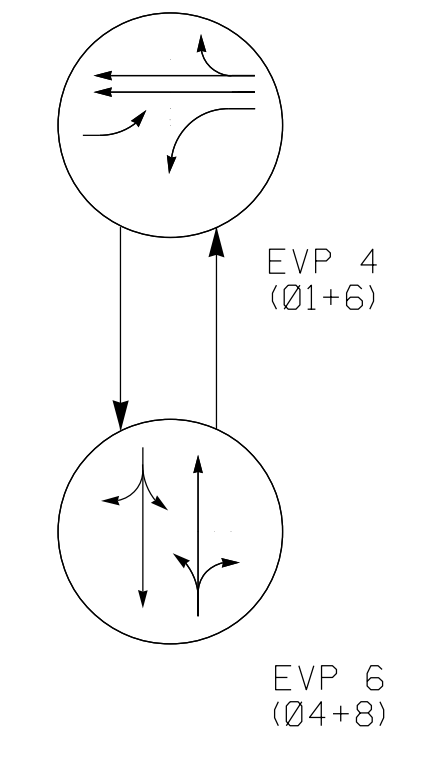

BRIDGE PREEMPT (PRE 3)

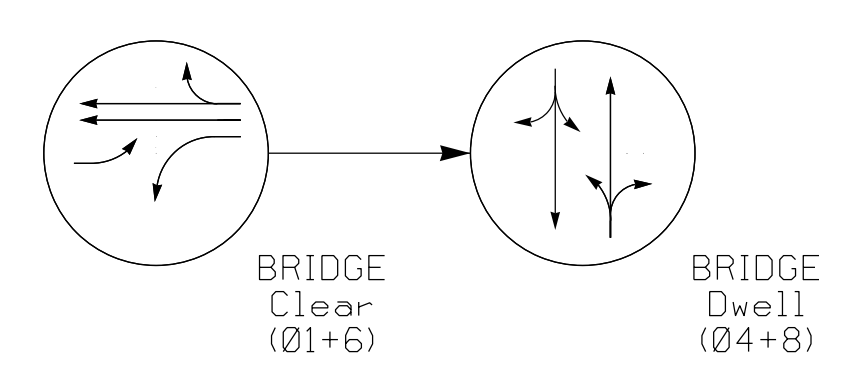

PHASING DIAGRAM DETECTION LEGEND

- ←●→ DETECTED MOVEMENT
- ←○→ UNDETECTED MOVEMENT (OVERLAP)
- ←○→ UNSIGNALIZED MOVEMENT
- ←○→ PEDESTRIAN MOVEMENT

TABLE OF OPERATION

SIGNAL FACE	PHASE							
	02+6	04+8	01+6	04+8	01+6	04+8	01+6	04+8
11	F	R	R	R	R	R	Y	Y
21	F	R	R	R	R	R	Y	Y
22, 23	G	R	R	R	R	R	Y	Y
41, 42	R	G	R	G	R	G	R	R
61, 62	G	R	G	R	G	R	Y	Y
81, 82	R	G	R	G	R	G	R	R
P41, P42	DW	W	DW	DW	DW	DW	DRK	DRK
P81, P82	DW	W	DW	DW	DW	DW	DRK	DRK

SIGNAL FACE I.D.

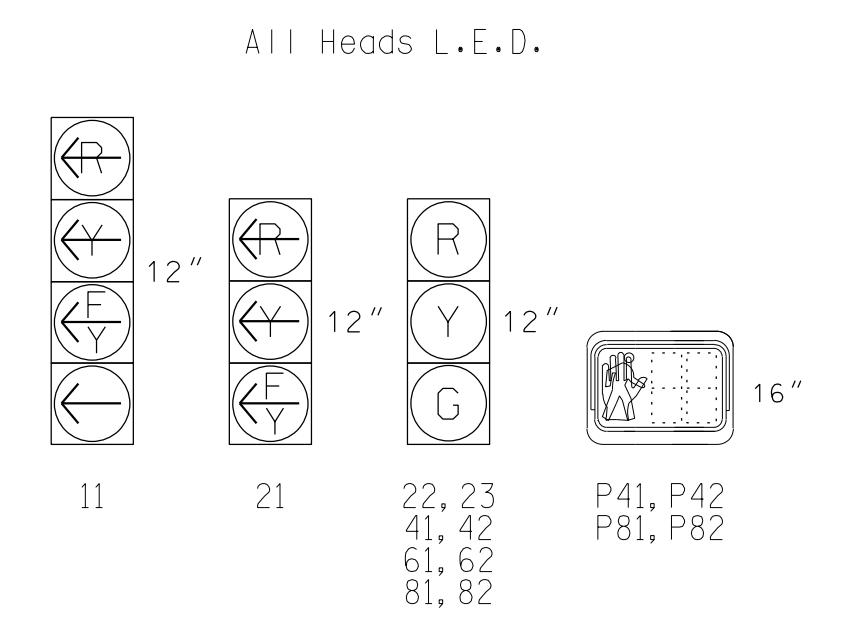

ASC/3 DETECTOR INSTALLATION CHART

LOOP	SIZE (FT)	DISTANCE FROM STOPBAR (FT)	TURNS	NEW LOOP	PROGRAMMING							
					PHASE	CALLING	EXTEND TIME	DELAY TIME	USE ADDED INITIAL	SYSTEM LOOP	NEW CARD	
2A	6x6	70	*	-	2	Yes	-	-	-	S	-	X
2B	6x6	70	*	-	2	Yes	-	-	-	S	-	X
2C	6x40	0	*	-	2	Yes	-	-	-	S	-	X
4A	6x40	0	*	-	4	Yes	-	5	-	S	-	X
6A	6x6	70	*	-	6	Yes	-	-	-	S	-	X
6B	6x6	70	*	-	6	Yes	-	-	-	S	-	X
6C	6x40	0	*	-	6	Yes	-	-	-	S	-	X
8A	6x40	0	*	-	8	Yes	-	5	-	S	-	X
S05	6x6	+80	*	-	-	-	-	-	-	N	X	X
S06	6x6	+80	*	-	-	-	-	-	-	N	X	X

ASC/3 EV PREEMPT

FUNCTION	PRE 4	PRE 6
Exit Phase(s)	2,6	2,6
Preempt Override	OFF	OFF
Delay Time	0	0
Ped Clear Through Yellow	Y	Y
Terminate Phases	N	N
Entrance Walk	255*	255*
Entrance Ped Clear	255*	255*
Entrance Min Green	1	1
Entrance Yellow Change	25.5*	25.5*
Entrance Red Clear	25.5*	25.5*
Minimum Dwell Time	10	7
Preempt Input Extension Time	2	2
Preempt Max Time	120	120
Exit Yellow Change	25.5*	25.5*
Exit Red Clear	25.5*	25.5*

* Allows normal phase times to be used.

ASC/3 TIMING CHART

FEATURE	PHASE				
	1	2	4	6	8
Min Green *	7	10	7	10	7
Delayed Green *	-	-	7	-	7
Walk *	0	0	7	0	7
Ped Clear	0	0	14	0	13
Veh. Extension *	2.0	3.0	2.0	3.0	2.0
Max 1 *	15	30	15	30	15
Yellow	3.0	3.8	3.3	3.8	3.3
Red Clear	2.1	1.3	2.2	1.3	2.1
Actuations B4 Add *	-	-	-	-	-
Seconds / Actuation *	-	-	-	-	-
Max Initial *	-	-	-	-	-
Time Before Reduction *	-	-	-	-	-
Time To Reduce *	-	-	-	-	-
Minimum Gap	-	-	-	-	-
Locking Detector	-	X	-	X	-
Recall Position	-	VEH. RECALL	-	VEH. RECALL	-
Dual Entry	-	-	X	-	X
Simultaneous Gap	X	X	X	X	X

* These values may be field adjusted. Do not adjust Min Green and Extension times for phases 2 and 6 lower than what is shown. Min Green for all other phases should not be lower than 4 seconds.

ASC/3 BRIDGE PREEMPT

FUNCTION	PRE 3
Exit Phase(s)	2,6
Preempt Override	ON
Delay Time	0
Ped Clear Through Yellow	N
Terminate Phases	N
Bridge Clear Reserve	Y
Entrance Walk	255*
Entrance Ped Clear	255*
Entrance Min Green	10
Entrance Yellow Change	25.5*
Entrance Red Clear	25.5*
Bridge Clear Min Green	25
Bridge Clear Yellow Change	3.8
Bridge Clear Red Clear	1.3
Min Dwell Time	10*
Exit Yellow Change	25.5*
Exit Red Clear	25.5*

* Time defaults to time used for phase during normal operation.

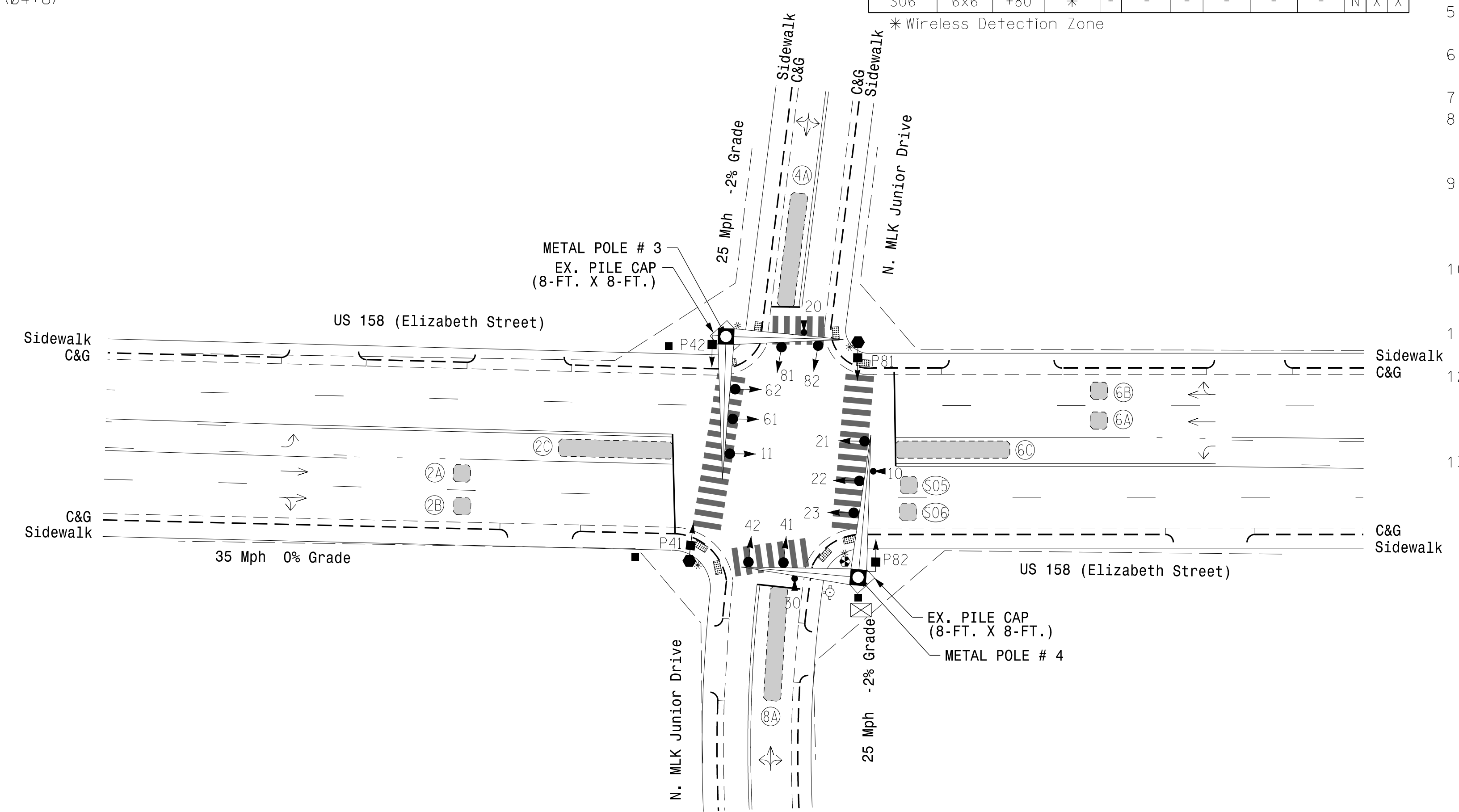

2 Phase Fully Actuated W/ EV and Bridge Preemption (Elizabeth City Signal System)

NOTES

- Refer to "Roadway Standard Drawings NCDOT" dated January 2018 and "Standard Specifications for Roads and Structures" dated January 2018.
- Do not program signal for late night flashing operation unless otherwise directed by the Engineer.
- Set all detector units to presence mode.
- Locate new cabinet so as not to obstruct sight distance of vehicles turning right on red.
- Omit "WALK" and flashing "DON'T WALK" with no pedestrian calls.
- Program pedestrian heads to countdown the flashing "Don't Walk" time only.
- Pavement markings are existing.
- This intersection features an optical preemption system. Shown locations of optical detectors are conceptual only.
- Relocate existing Optical detection equipment from existing cabinet to new cabinet. Install a new 2-channel phase selector and return 4-channel phase selector to the Department.
- Optical detector 10 calls EVP 4. Optical detector 20 calls EVP 6. Optical detector 30 calls EVP 6.
- Relocate existing wireless detection equipment from existing cabinet to new cabinet.
- Relocate existing FO transceivers and contact closures with all associated equipment for bridge preemption at this location and 01-0009 and 01-0010 from existing cabinet to new cabinet.
- Maximum times shown in timing chart are for free-run operation only. Coordinated signal system timing values supersede these values.

LEGEND

- | PROPOSED | EXISTING |
|---------------------------------|---------------------------------|
| ○→ Traffic Signal Head | ●→ Traffic Signal Head |
| ○→ Modified Signal Head | N/A |
| ○→ Pedestrian Signal Head | ○→ Pedestrian Signal Head |
| * With Push Button & Sign | * With Push Button & Sign |
| ○ Type II Signal Pedestal | ○ Type II Signal Pedestal |
| ○ Type I Pushbutton Post | ○ Type I Pushbutton Post |
| ○ Signal Pole with Guy | ○ Signal Pole with Guy |
| ○ Signal Pole with Sidewalk Guy | ○ Signal Pole with Sidewalk Guy |
| ⊠ Wireless Detection Zone | ⊠ Wireless Detection Zone |
| ⊠ Controller & Cabinet | ⊠ Controller & Cabinet |
| ⊠ Junction Box | ⊠ Junction Box |
| --- 2-in Underground Conduit | --- 2-in Underground Conduit |
| N/A Right of Way | N/A Right of Way |
| → Directional Arrow | → Directional Arrow |
| N/A Fire Hydrant | N/A Fire Hydrant |
| ○ Metal Pole with Mastarm | ○ Metal Pole with Mastarm |
| ○ Optical Detector | ○ Optical Detector |
| N/A Truncated Dome | N/A Truncated Dome |

Signal Upgrade

Prepared for the Offices of:

 Plans Prepared By:

 DRMP, Inc.
 8000 Regency Parkway, Suite 175
 Cary, NC 27519
 NC License No. C-2213 (919) 650-1038

US 158 (Elizabeth Street) at N. MLK Junior Drive

Division 1 Pasquotank County Elizabeth City

PLAN DATE: February 2018 REVIEWED BY: AJ Davis

PREPARED BY: JA Le REVIEWED BY: LM Moon

REVISIONS: INIT. DATE

SCALE: 1"=30'

DOCUMENT NOT CONSIDERED FINAL UNLESS ALL SIGNATURES COMPLETED

SEAL
 NORTH CAROLINA PROFESSIONAL ENGINEER
 SEAL 022516
 LISA M. MOON
 DATE: 9/20/2018
 SIG. INVENTORY NO. 01-0008

20-SEP-2018 16:34
 R:\05942\51\001\DWG\Signal\01-0008-08212018.dgn
 LMOON AT CAR-LMOON-W

EDI MODEL 2018EClip-NC CONFLICT MONITOR PROGRAMMING DETAIL

(remove jumpers and set switches as shown)

REMOVE DIODE JUMPERS 1-6, 1-9, 1-11, 2-6, 2-9, 2-11, 4-8, 4-14, 4-16, 6-9, 6-11, 8-14, 8-16, 9-11 and 14-16.

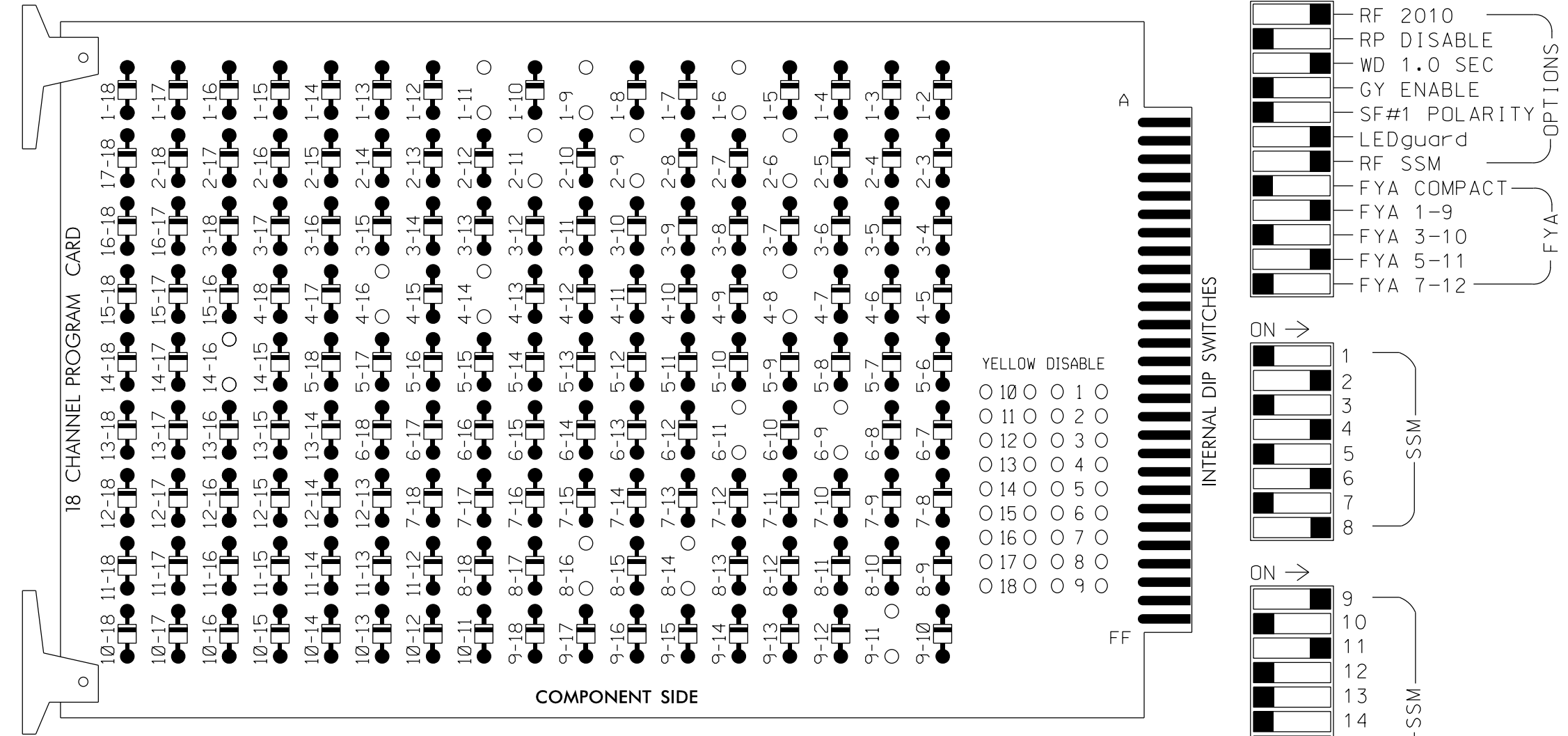

REMOVE JUMPERS AS SHOWN

NOTES:

- Card is provided with all diode jumpers in place. Removal of any jumper allows its channels to run concurrently.
- Ensure jumpers SEL2-SEL5 and SEL9 are present on the monitor board.
- Ensure that Red Enable is active at all times during normal operation.
- Integrate monitor with Ethernet network in cabinet.

NOTES

- To prevent "flash-conflict" problems, insert red flash program blocks for all unused vehicle load switches in the output file. The installer shall verify that signal heads flash in accordance with the Signal Plans.
- Program phases 4 and 8 for Dual Entry.
- Program controller to start up in phase 2 Green and 6 Green.
- The cabinet and controller are part of the Elizabeth City Signal System.
- Ensure Delayed Green times shown in the Timing Chart on the signal design plan are accounted for to facilitate leading pedestrian interval.

EQUIPMENT INFORMATION

CONTROLLER.....2070LX
 CABINET.....332 W/AUX
 SOFTWARE.....ECONOLITE ASC/3-2070
 CABINET MOUNT.....BASE
 OUTPUT FILE POSITIONS...18 WITH AUX. OUTPUT FILE
 LOAD SWITCHES USED.....S1,S2,S5,S6,S8,S11,S12,
 AUX S1,AUX S4
 PHASES USED.....1**,2,4,4PED,6,8,8PED
 OVERLAP "A".....*
 OVERLAP "B".....NOT USED
 OVERLAP "C".....*
 OVERLAP "D".....NOT USED
 * See overlap programming detail on sheet 3
 ** Phase 1 used only during preemption.

SIGNAL HEAD HOOK-UP CHART

LOAD SWITCH NO.	S1	S2	S3	S4	S5	S6	S7	S8	S9	S10	S11	S12	AUX S1	AUX S2	AUX S3	AUX S4	AUX S5	AUX S6
CMU CHANNEL NO.	1	2	13	3	4	14	5	6	15	7	8	16	9	10	17	11	12	18
PHASE	1	2	2 PED	3	4	4 PED	5	6	6 PED	7	8	8 PED	OLA	OLB	SPARE	OLC	OLD	SPARE
SIGNAL HEAD NO.	11	22,23	NU	NU	41,42	P41, P42	NU	61,62	NU	NU	81,82	P81, P82	11	NU	NU	21	NU	NU
RED		128			101			134			107							
YELLOW	*	129			102			135			108							
GREEN		130			103			136			109							
RED ARROW													A121			A114		
YELLOW ARROW													A122			A115		
FLASHING YELLOW ARROW													A123			A116		
GREEN ARROW	127																	
Hand icon						104						110						
Person icon						106						112						

NU = Not Used

* Denotes install load resistor. See load resistor installation detail this sheet.

★ See pictorial of head wiring in detail this sheet.

COUNTDOWN PEDESTRIAN SIGNAL OPERATION

Countdown Ped Signals are required to display timing only during Ped Clearance Interval. Consult Ped Signal Module user's manual for instructions on selecting this feature.

INPUT FILE POSITION LAYOUT

(front view)

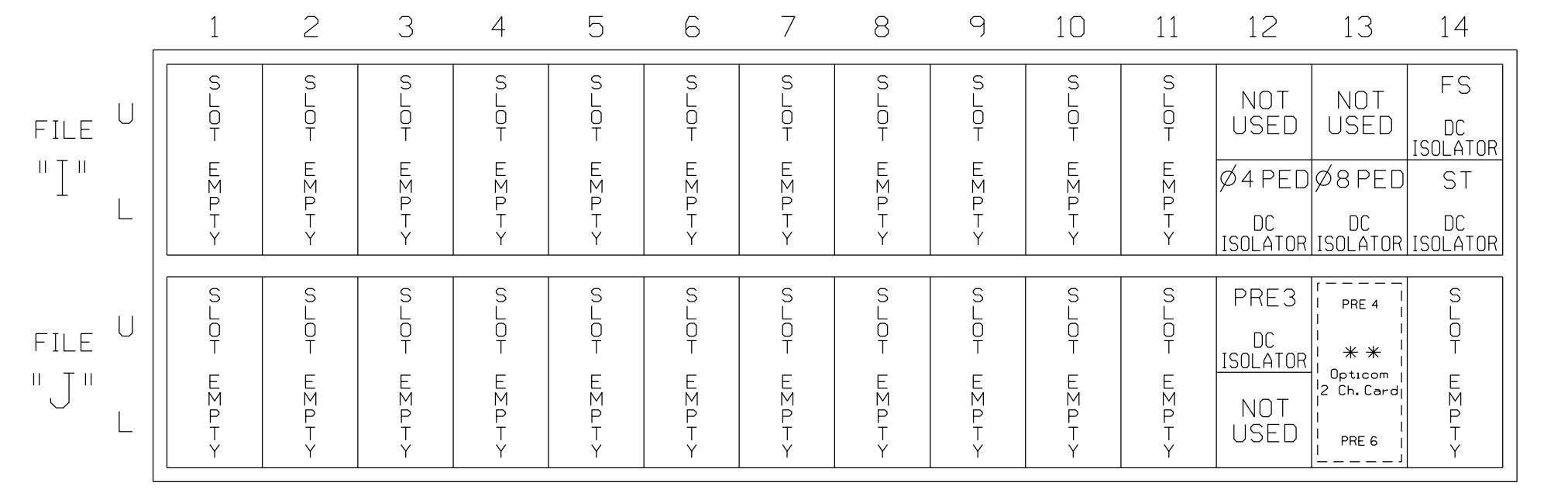

EX.: 1A, 2A, ETC. = LOOP NO.'S
 NU = CHANNEL NOT USED
 * See Sensys Access Box Wiring Detail the sheet.

FS = FLASH SENSE
 ST = STOP TIME
 EV PREEMPT = PRE4 & PRE6
 BRIDGE PREEMPT = PRE3

INPUT FILE CONNECTION & PROGRAMMING CHART

LOOP NO.	LOOP TERMINAL	INPUT FILE POS.	PIN NO.	DETECTOR NO.	NEMA PHASE	CALL	EXTEND TIME	DELAY TIME	ADDED INITIAL	DETECTOR TYPE
PED PUSH BUTTONS										
P41,P42	T88-5,6	I12L	69	PED 4	4 PED					
P81,P82	T88-8,9	I13L	70	PED 8	8 PED					

NOTE:
 INSTALL DC ISOLATORS IN INPUT FILE SLOTS 112 AND 113.

* System detector only. Remove any assigned vehicle phase.

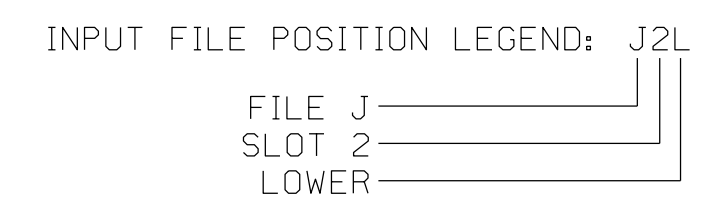

FYA SIGNAL WIRING DETAIL

(wire signal heads as shown)

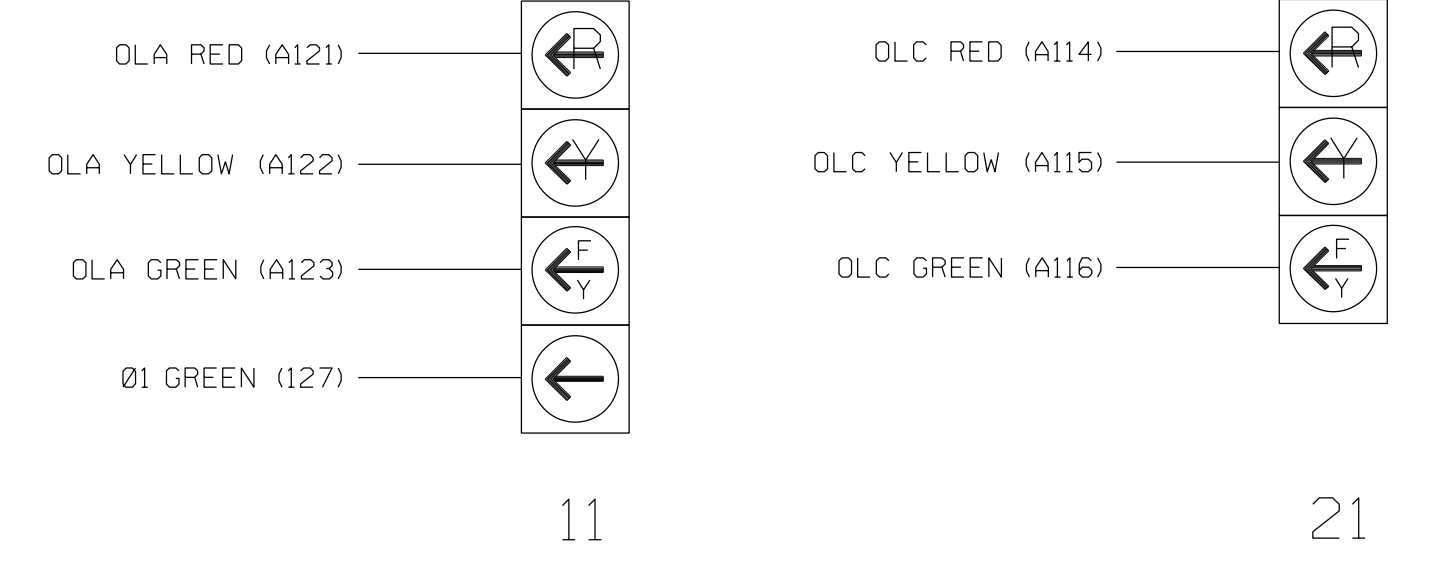

NOTE
 See overlap programming instructions on sheet 3 of 5

**OPTICAL PREEMPTION SYSTEM

- Install an optical preemption system for emergency vehicle preemption. Perform installation according to manufacturer's directions and NCDOT engineer-approved mounting locations to accomplish the preemption schemes shown on the Signal Design Plans.
- Ensure that the Optical Preemption System is fully compatible with equipment manufactured in accordance with the specification of the type 2070 controller.

WIRELESS DETECTION SYSTEM

- For all loops install a Wireless Vehicle Detection System for vehicle detection. Perform installation according to manufacturer's directions and NCDOT Engineer-approved mounting locations to accomplish the detection schemes shown on the signal design plans.
- Ensure that the Wireless Vehicle Detection System is fully compatible with equipment manufactured in accordance with the specifications for the type 2070 controller.

Electrical Detail - Sheet 1 of 5

Electrical and Programming Details For:

DRMP, Inc.
 8000 Regency Parkway, Suite 175
 Cary, NC 27519
 NC License No. C-2215 (919) 650-1038

US 158 (Elizabeth Street) at N. MLK Junior Drive

Division 1 Pasquotank County Elizabeth City

PLAN DATE: February 2018 REVIEWED BY: AJ Davis

PREPARED BY: DJ White REVIEWED BY: LM Moon

REVISIONS INIT. DATE

DOCUMENT NOT CONSIDERED FINAL UNLESS ALL SIGNATURES COMPLETED

SEAL

DocuSigned by: Lisa M. Moon 9/20/2018

SIG. INVENTORY NO. 01-0008

ECONOLITE ASC/3-2070 LOGIC PROCESSOR PROGRAMMING DETAIL TO PRODUCE SPECIAL FYA-PPLT SIGNAL SEQUENCE

(program controller as shown)

1. From Main Menu select 1. CONFIGURATION
2. From CONFIGURATION Submenu select 8. LOGIC PROCESSOR
3. From the LOGIC PROCESSOR Submenu select 2. LOGIC STATEMENTS

ENTER A "1" IN THE LP# FIELD, PRESS 'ENTER', AND PROGRAM AS SHOWN.

LP#:	1	COPY FROM:	1	ACTIVE:	M	(T/F)	
IF	PMT PREEMPT ACTIVE	3	IS	OFF			
AND	PMT PREEMPT ACTIVE	4	IS	OFF			
THEN	CTR OMIT PHASE	1	ON				
ELSE							

LOGIC FOR OMITTING PHASE 1 AT START UP AND/OR WHEN NOT IN PREEMPT

4. From the LOGIC PROCESSOR Submenu select 1. LOGIC STATEMENT CONTROL

ENABLE LOGIC PROCESSOR STATEMENT 1 BY POSITIONING THE CURSOR OVER THE FIELDS SHOWN BELOW AND USING THE TOGGLE KEY TO ENABLE THEM .

LOGIC STATEMENT CONTROL																
	1	2	3	4	5	6	7	8	9	0	1	2	3	4	5	6
LP 1-15	E
LP 16-30
LP 31-45
LP 46-60
LP 61-75
LP 76-90

END PROGRAMMING

ECONOLITE ASC/3-2070 OVERLAP PROGRAMMING DETAIL

(program controller as shown)

1. From Main Menu select 2. CONTROLLER
2. From CONTROLLER Submenu select 2. VEHICLE OVERLAPS

OVERLAP A

Select TMG VEH OVLP [A] and 'PPLT FYA'

TMG VEH OVLP...[A] TYPE:	PPLT FYA
PROTECTED LEFT TURN....	PHASE	1
OPPOSING THROUGH.....	PHASE	2
FLASHING ARROW OUTPUT.....	CH9	ISOLATE
DELAY START OF: FYA..0.0	CLEARANCE..0.0	
ACTION PLAN SF BIT DISABLE.....	0	

Toggle Twice

OVERLAP C

Select TMG VEH OVLP [C] and 'OTHER/ECONOLITE'

TMG VEH OVLP...[C] TYPE:	OTHER/ECONOLITE
PHASES 1 2 3 4 5 6 7 8 9 0 1 2 3 4 5 6	
INCLUDED	X
PROTECT
PED PRTC
NOT OVLP
FLSH GRN	1
LAG X PH
LAG 2 PH
LAG GRN 0.0 YEL 0.0 RED 0.0 ADV GRN 0.0	

END PROGRAMMING

THIS ELECTRICAL DETAIL IS FOR THE SIGNAL DESIGN: 01-0008
DESIGNED: FEBRUARY 2018
SEALED: 09/20/2018
REVISED: N/A

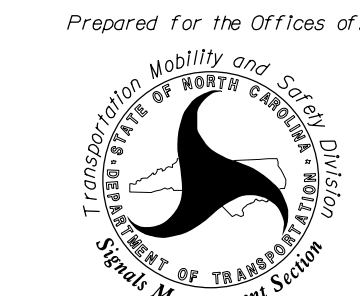
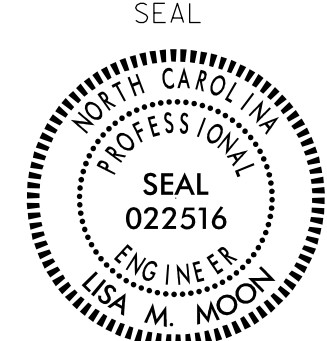
<p style="font-size: x-small;">ELECTRICAL AND PROGRAMMING DETAILS FOR:</p> <p style="font-size: x-small;">Prepared for the Offices of:</p> <div style="text-align: center;">  </div>	<p>US 158 (Elizabeth Street) at N. MLK Junior Drive</p> <p>Division 1 Pasquotank County Elizabeth City</p> <p>PLAN DATE: February 2018 REVIEWED BY: AJ Davis</p> <p>PREPARED BY: DJ White REVIEWED BY: LM Moon</p> <table border="1" style="width: 100%; border-collapse: collapse; font-size: x-small;"> <tr> <th>REVISIONS</th> <th>INIT.</th> <th>DATE</th> </tr> <tr> <td> </td> <td> </td> <td> </td> </tr> <tr> <td> </td> <td> </td> <td> </td> </tr> </table>	REVISIONS	INIT.	DATE							<p>SEAL</p> <div style="text-align: center;">  </div> <p>DocuSigned by: <i>Lisa M. Moon</i> 9/20/2018</p> <p style="font-size: x-small;">SIC INVENTORY NO. 01-0008</p>
REVISIONS	INIT.	DATE									



ECONOLITE ASC/3-2070 EMERGENCY VEHICLE PREEMPT PROGRAMMING DETAIL

(program controller as shown)

- From Main Menu select **4. PREEMPTOR/TSP**
- From PREEMPTOR/TSP/SCP Submenu select **1. PREEMPT PLAN 1-10**

Place cursor in [] next to Preempt Plan and press 4. Then press the right cursor arrow and toggle the controller to YES. Next cursor down. This will select Emergency Vehicle Preempt #4.

```

PREEMPT PLAN [ 4]  ENABLE....YES
VEH/PED 1 2 3 4 5 6 7 8 9 0 1 2 3 4 5 6
OVERLAP A B C D E F G H I J K L M N O P
TRKCLR V . . . . .
TRKCLR O . . . . .
ENA TRL . . . . .
DWEL VEH X . . . . X . . . . .
DWEL PED . . . . .
DWEL OLPF1 .F1 . . . . .
CYC VEH . . . . .
CYC PED . . . . .
CYC OLP . . . . .
EXIT PH . X . . . . X . . . . .
EXIT CAL . . . . .
SP FUNC . . . . .

```

```

ENABLE... YESIPMT OVRIDE..INTERLOCK. NO
DET LOCK... XIDELAY.. 0IINHIBIT... 0
OVERIDE FL. .IDURATION 0ICLR-GRN... NO
TERM OLP. NOIPC>YEL YESITERM PH NO
PED DARK.. NOITC RESRV NOIDWELL FL OFF
LINK PMT....0IX FLCOLR REDIEXIT OPT. OFF
X TMG PLN...0IRE-SERV.. 0IFLT TYPE.HARD
FREE DUR PMTIR1 NOIR2 NOIR3 NOIR4 NO
--TIMING----WALKIPED CLIMN GRI YELI RED
ENTRANCE TM. 255I 255I 1125.5125.5
-----MIN GRIEXT GRIMX GRI YELI RED
TRACK CLEAR 0I 0I 0125.5125.5
-----MIN DLIPMTEXTIMX TMI YELI RED
DWL/CYC-EXIT 10I 2.0I 120125.5125.5
PMT ACTIVE OUT..ON PMT ACT DWELL...NO
OTHER - PRI PMT.OFF NON-PRI PMT....OFF
INH EXT TIME... 0.0 PED PR RETURN...OFF
PRIORITY RETURN.OFF QUEUE DELAY.... OFF
COND DELAY.....OFF

```

```

PHASES 1 2 3 4 5 6 7 8
PR RTN% 0 0 0 0 0 0 0 0
PHASES 9 10 11 12 13 14 15 16
PR RTN% 0 0 0 0 0 0 0 0

```

Place cursor in [] next to Preempt Plan and press 6. Then press the right cursor arrow and toggle the controller to YES. Next cursor down. This will select Emergency Vehicle Preempt #6.

```

PREEMPT PLAN [ 6]  ENABLE....YES
VEH/PED 1 2 3 4 5 6 7 8 9 0 1 2 3 4 5 6
OVERLAP A B C D E F G H I J K L M N O P
TRKCLR V . . . . .
TRKCLR O . . . . .
ENA TRL . . . . .
DWEL VEH . . . . X . . . . X . . . . .
DWEL PED . . . . .
DWEL OLP . . . . .
CYC VEH . . . . .
CYC PED . . . . .
CYC OLP . . . . .
EXIT PH . X . . . . X . . . . .
EXIT CAL . . . . .
SP FUNC . . . . .

```

```

ENABLE... YESIPMT OVRIDE..INTERLOCK. NO
DET LOCK... XIDELAY.. 0IINHIBIT... 0
OVERIDE FL. .IDURATION 0ICLR-GRN... NO
TERM OLP. NOIPC>YEL YESITERM PH NO
PED DARK.. NOITC RESRV NOIDWELL FL OFF
LINK PMT....0IX FLCOLR REDIEXIT OPT. OFF
X TMG PLN...0IRE-SERV.. 0IFLT TYPE.HARD
FREE DUR PMTIR1 NOIR2 NOIR3 NOIR4 NO
--TIMING----WALKIPED CLIMN GRI YELI RED
ENTRANCE TM. 255I 255I 1125.5125.5
-----MIN GRIEXT GRIMX GRI YELI RED
TRACK CLEAR 0I 0I 0125.5125.5
-----MIN DLIPMTEXTIMX TMI YELI RED
DWL/CYC-EXIT 7I 2.0I 120125.5125.5
PMT ACTIVE OUT..ON PMT ACT DWELL...NO
OTHER - PRI PMT.OFF NON-PRI PMT....OFF
INH EXT TIME... 0.0 PED PR RETURN...OFF
PRIORITY RETURN.OFF QUEUE DELAY.... OFF
COND DELAY.....OFF

```

```

PHASES 1 2 3 4 5 6 7 8
PR RTN% 0 0 0 0 0 0 0 0
PHASES 9 10 11 12 13 14 15 16
PR RTN% 0 0 0 0 0 0 0 0

```

ECONOLITE ASC/3-2070 PREEMPT FILTERING PROGRAMMING DETAIL

(program controller as shown)

- From Main Menu select **4. PREEMPTOR/TSP**
- From PREEMPT/TSP/SCP Submenu select **2. ENABLE PREEMPT FILTERING & TSP/SCP**

```

ENABLE PREEMPT FILTERING & TSP/SCP
FILTERED SOLID PULSING
INPUT 1 ...BYPASSED... ...BYPASSED..
2 ...BYPASSED... ...BYPASSED..
3 ..PREEMPT 3. ...BYPASSED..
4 ..PREEMPT 4. ...BYPASSED..
5 ..PREEMPT 5. ...BYPASSED..
6 ..PREEMPT 6. ...BYPASSED..
7 ...BYPASSED... ...BYPASSED..
8 ...BYPASSED... ...BYPASSED..
9 ...BYPASSED... ...BYPASSED..
10 ...BYPASSED... ...BYPASSED..

```

THIS ELECTRICAL DETAIL IS FOR THE SIGNAL DESIGN: 01-0008
DESIGNED: FEBRUARY 2018
SEALED: 09/20/2018
REVISED: N/A

20-SEP-2018 18:51 R:\415942\51\001\415942.dgn AT: CAR-L\MOON-M

Electrical Detail - Sheet 4 of 5

DOCUMENT NOT CONSIDERED FINAL UNLESS ALL SIGNATURES COMPLETED



ELECTRICAL AND PROGRAMMING DETAILS FOR:

Prepared for the Offices of:

DRMP, Inc.
8000 Regency Parkway, Suite 175
Cary, NC 27519
NC License No. C-2215 (919) 650-1038

US 158 (Elizabeth Street) at N. MLK Junior Drive

Division 1 Pasquotank County Elizabeth City

PLAN DATE: February 2018 REVIEWED BY: AJ Davis

PREPARED BY: DJ White REVIEWED BY: LM Moon

REVISIONS	INIT.	DATE

SEAL

DocuSigned by: Lisa M. Moon 9/20/2018

SIG. INVENTORY NO. 01-0008

EDI MODEL 2018EClip-NC CONFLICT MONITOR PROGRAMMING DETAIL

(remove jumpers and set switches as shown)

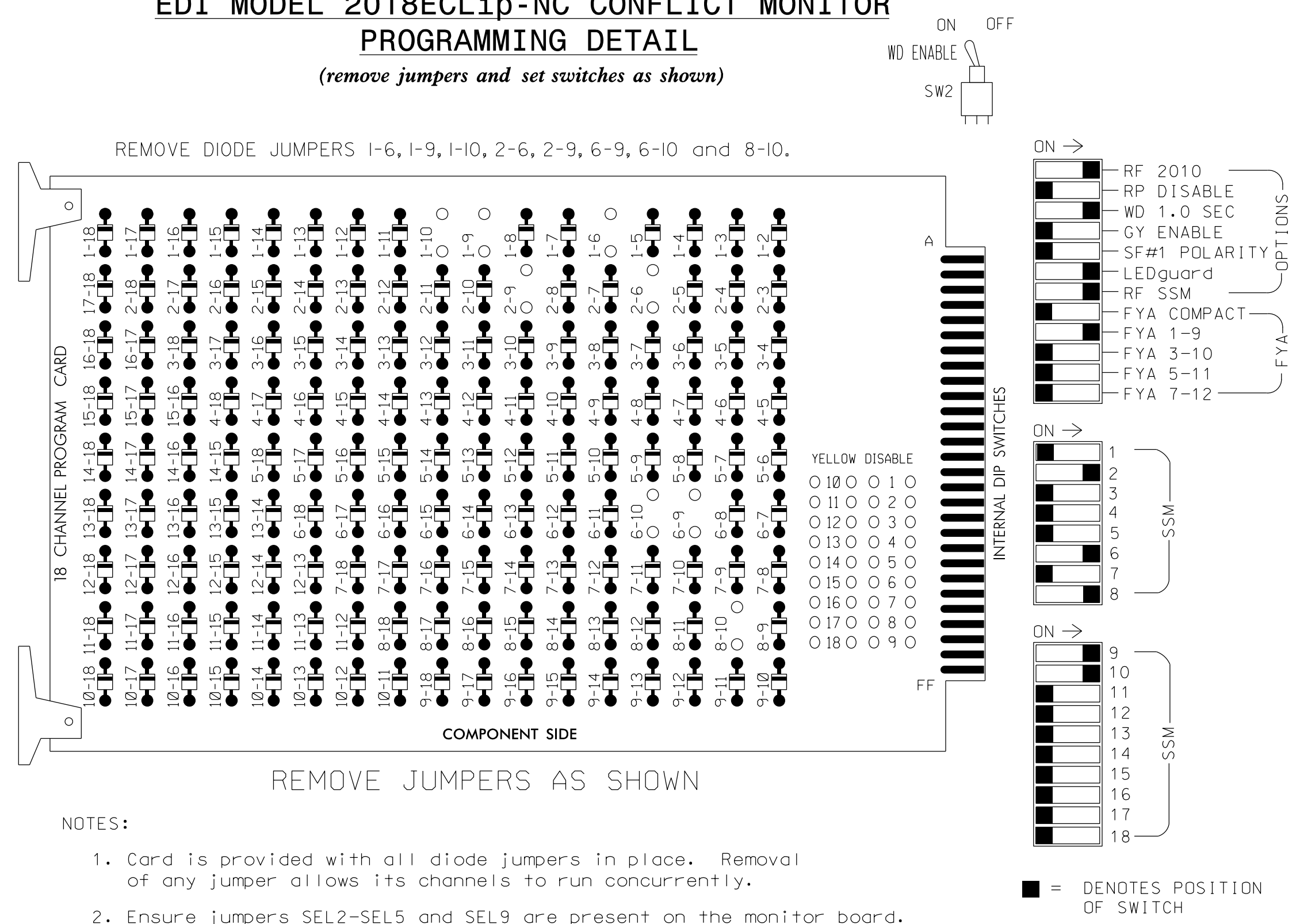

NOTES

- To prevent "flash-conflict" problems, insert red flash program blocks for all unused vehicle load switches in the output file. The installer shall verify that signal heads flash in accordance with the Signal Plans.
- Program controller to start up in phase 2 Green and 6 Green.
- The cabinet and controller are part of the Elizabeth City Signal System.
- Ensure Delayed Green times shown in the Timing Chart on the signal design plan are accounted for to facilitate leading pedestrian interval.

EQUIPMENT INFORMATION

CONTROLLER.....2070LX
 CABINET.....332 W/AUX
 SOFTWARE.....ECONOLITE ASC/3-2070
 CABINET MOUNT.....BASE
 OUTPUT FILE POSITIONS...18 WITH AUX. OUTPUT FILE
 LOAD SWITCHES USED.....S1,S2,**S3,S8,S11,AUX S1,AUX S2
 PHASES USED.....1,2,6,8
 OVERLAP "A".....*
 OVERLAP "B".....*
 OVERLAP "C".....NOT USED
 OVERLAP "D".....NOT USED

* See overlap programming detail on sheet 3
 ** Used for preempt status control

SIGNAL HEAD HOOK-UP CHART

LOAD SWITCH NO.	S1	S2	S3	S4	S5	S6	S7	S8	S9	S10	S11	S12	AUX S1	AUX S2	AUX S3	AUX S4	AUX S5	AUX S6
CNU CHANNEL NO.	1	2	13	3	4	14	5	6	15	7	8	16	9	10	17	11	12	18
PHASE	1	2	2 PED	3	4	4 PED	5	6	6 PED	7	8	8 PED	OLA	OLB	SPARE	OLC	OLD	SPARE
SIGNAL HEAD NO.	11	21,22	NU	NU	NU	NU	NU	61,62	NU	NU	81,82	NU	11	82	NU	NU	NU	NU
RED		128						134			107			*				
YELLOW	*	129						135			108							
GREEN		130						136			109							
RED ARROW														A121				
YELLOW ARROW														A122	A125			
FLASHING YELLOW ARROW														A123				
GREEN ARROW	127																	A126

NU = Not Used
 * Denotes install load resistor. See load resistor installation detail this sheet.
 ★ See pictorial of head wiring in detail this sheet.

INPUT FILE POSITION LAYOUT

(front view)

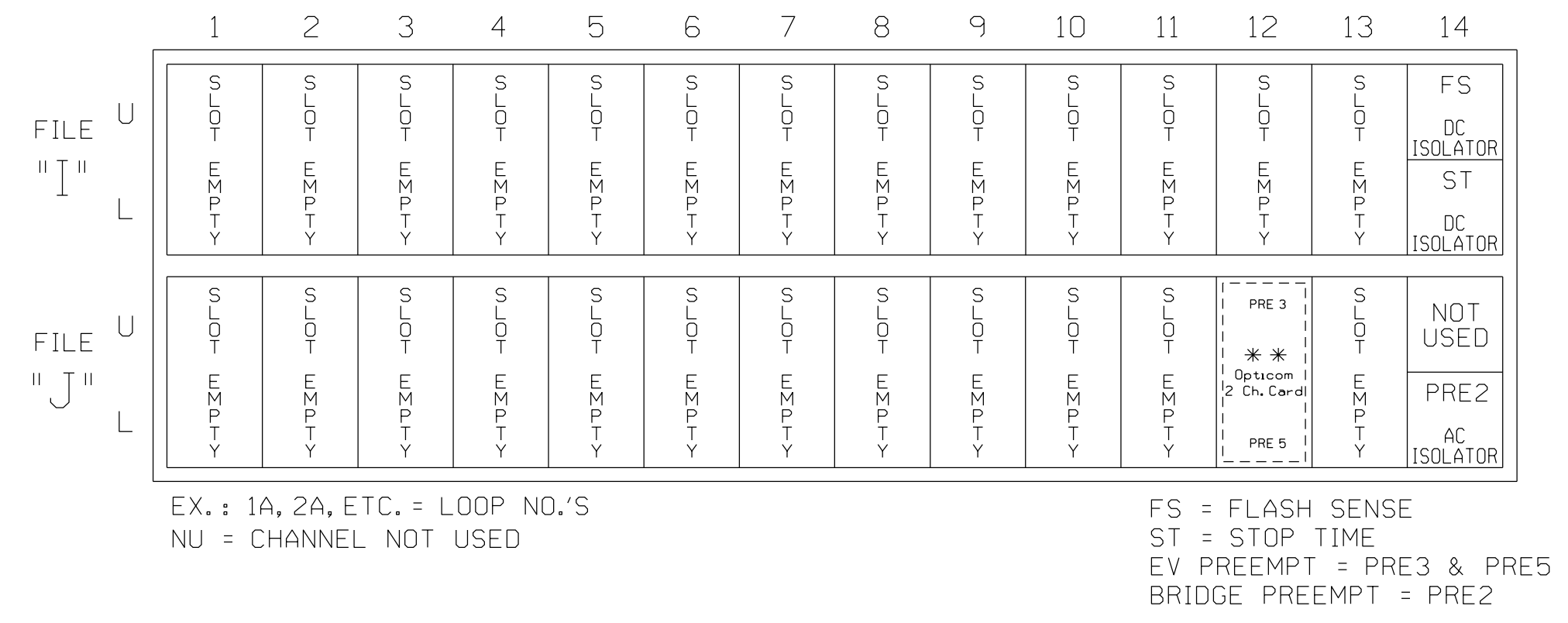

FYA SIGNAL WIRING DETAIL

(wire signal heads as shown)

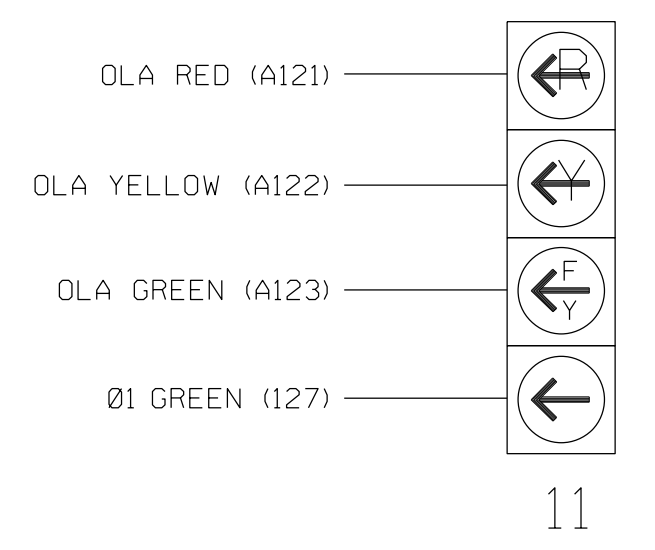

LOAD RESISTOR INSTALLATION DETAIL

(install resistors as shown)

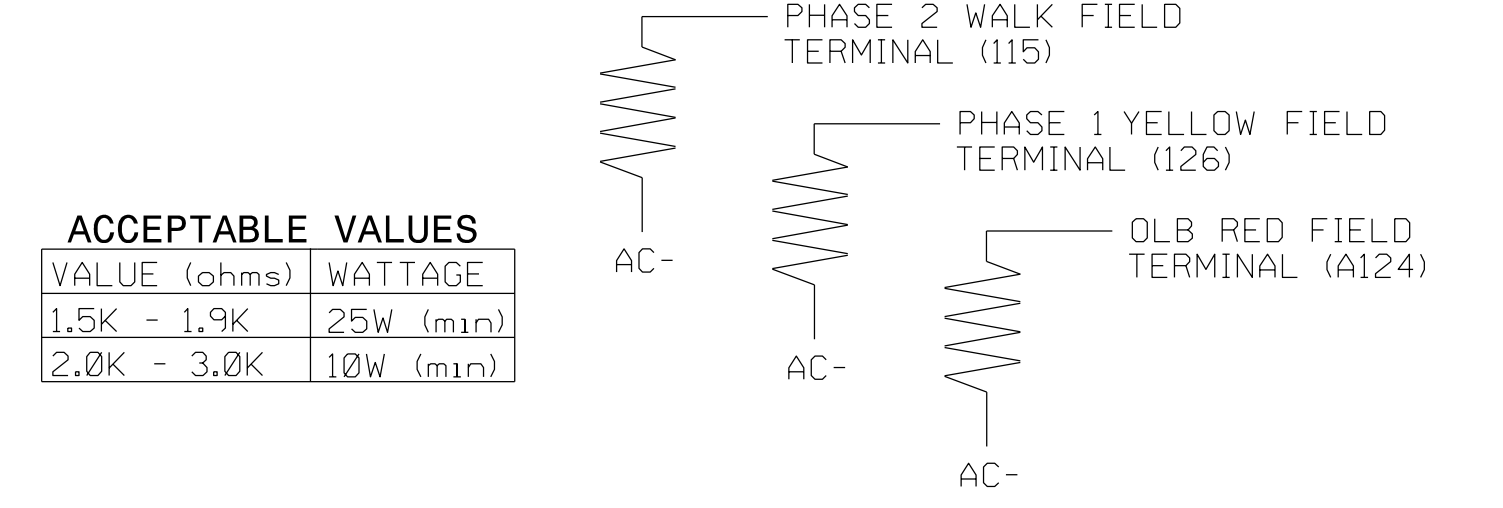

**OPTICAL PREEMPTION SYSTEM

- Install an optical preemption system for emergency vehicle preemption. Perform installation according to manufacturer's directions and NCDOT engineer-approved mounting locations to accomplish the preemption schemes shown on the Signal Design Plans.
- Ensure that the Optical Preemption System is fully compatible with equipment manufactured in accordance with the specification of the type 2070 controller.

WIRELESS DETECTION SYSTEM

- For all loops install a Wireless Vehicle Detection System for vehicle detection. Perform installation according to manufacturer's directions and NCDOT Engineer-approved mounting locations to accomplish the detection schemes shown on the signal design plans.
- Ensure that the Wireless Vehicle Detection System is fully compatible with equipment manufactured in accordance with the specifications of the type 2070 controller.

THIS ELECTRICAL DETAIL IS FOR THE SIGNAL DESIGN: 01-0010
 DESIGNED: FEBRUARY 2018
 SEALED: 08/22/2018
 REVISED: N/A

Electrical Detail - Sheet 1 of 4

DRMP, Inc.
 8000 Regency Parkway, Suite 175
 Cary, NC 27519
 NC License No. C-2415 (019) 650-1038

US 158 (Elizabeth Street) at Water Street

Division 1 Pasquotank County Elizabeth City

PLAN DATE: February 2018 REVIEWED BY: AJ Davis
 PREPARED BY: DJ White REVIEWED BY: LM Moon

DOCUMENT NOT CONSIDERED FINAL UNLESS ALL SIGNATURES COMPLETED

SEAL

SEAL 022516

ENGINEER LISA M. MOON

DocuSigned by: Lisa M. Moon 9/20/2018

SIG. INVENTORY NO. 01-0010

ECONOLITE ASC/3-2070 BRIDGE PREEMPT PROGRAMMING DETAIL

1. From Main Menu select 4. PREEMPTOR/TSP
2. From PREEMPTOR/TSP/SCP Submenu select 1. PREEMPT PLAN 1-10

Place cursor in [] next to Preempt Plan and press 3. Then press the right cursor arrow and toggle the controller to YES. Next cursor down. This will select Emergency Vehicle Preempt #3.

PREEMPT PLAN [3]	ENABLE....YES
VEH/PED 1 2 3 4 5 6 7 8 9 0 1 2 3 4 5 6	
OVERLAP A B C D E F G H I J K L M N O P	
TRKCLR V X X	
TRKCLR OF1	
ENA TRL	
DWEL VEH X	
DWEL PED	
DWEL OLP	
CYC VEH	
CYC PED	
CYC OLP	
EXIT PH . X . . . X	
EXIT CAL	
SP FUNC	

ENABLE... YES	IPMT	OVRIDE	X	INTERLOCK	NO
DET LOCK... X	IDELAY..	O	INHIBIT...	0	
OVERIDE FL. .	IDURATION	O	ICLR-GRN...	NO	
TERM OLP. NO	IPC>YEL	NO	TERM PH	NO	
PED DARK.. NO	ITC RESRV	YES	IDWELL FL	OFF	
LINK PMT....O	IX FLCOLR	RED	EXIT OPT.	OFF	
X TMG PLN...O	IRE-SERV..	O	FLT TYPE	HARD	
FREE DUR PMT	IR1 NOIR2	NOIR3	NOIR4	NO	
--TIMING----	WALKIPED	CLIMN	GRI YELI	RED	
ENTRANCE TM.	255I 255I	1125.5	125.5		
-----MIN	GRIEXT	GRIMX	GRI YELI	RED	
TRACK CLEAR	25I 0I	0125.5	125.5		
-----MIN	DLIPMTEXT	IMX TMI	YELI	RED	
DWL/CYC-EXIT	10I 0.0I	225125.5	125.5		
PMT ACTIVE	OUT..ON	PMT ACT	DWELL...	NO	
OTHER - PRI	PMT.OFF	NON-PRI	PMT.....	OFF	
INH EXT	TIME... 0.0	PED PR	RETURN...	OFF	
PRIORITY	RETURN.OFF	QUEUE	DELAY....	OFF	
COND	DELAY.....	OFF			
PHASES	1 2 3 4 5 6 7 8				
PR RTN%	0 0 0 0 0 0 0 0				
PHASES	9 10 11 12 13 14 15 16				
PR RTN%	0 0 0 0 0 0 0 0				

BRIDGE PREEMPTION WIRING DETAIL

(wire as shown below)

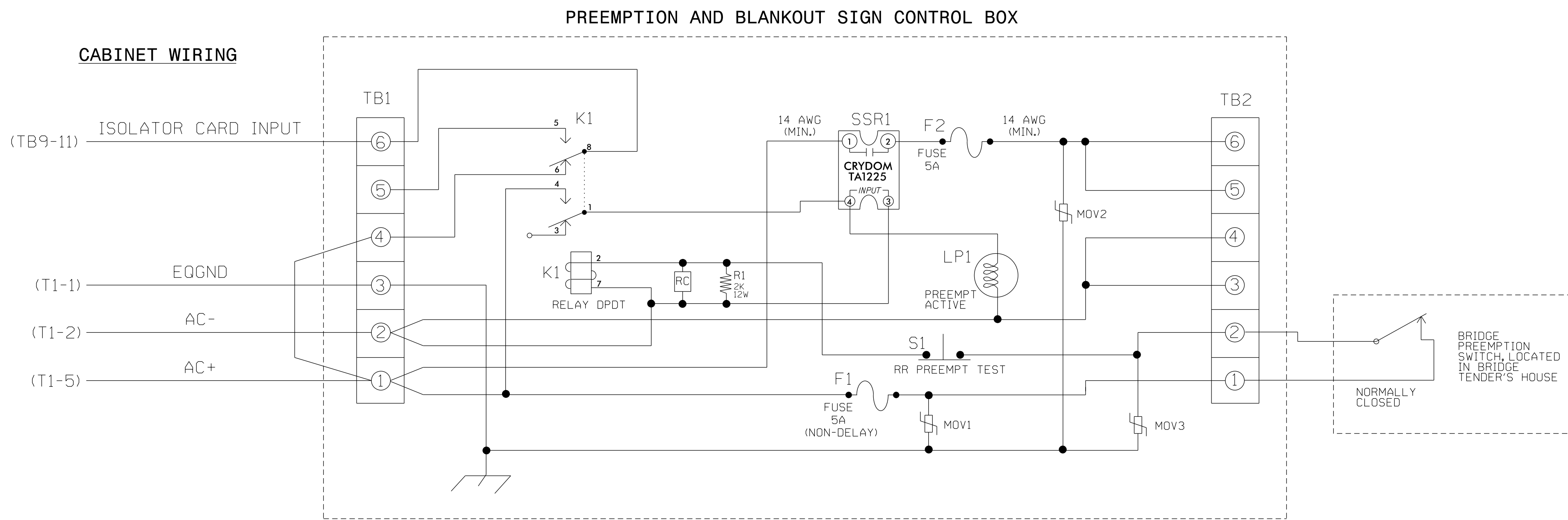

NOTES

1. Relay K1 is shown in the energized (Preempt not active) normal operation state.
2. Relay K1 is a DPDT with 120VAC coil with actual base.
3. Relay SSR1 is a SPST (normally open) Solid State Relay with AC input and AC (25 amp) output.
4. AC Isolator Card shall activate preemption upon removal of AC+ from the input (as shown above). To accomplish this set invert dip switch on AC Isolator Card.
5. IMPORTANT!! Terminal TB9-12 (on input panel) shall be connected to AC neutral (jumper may have to be added).

FRONT VIEW

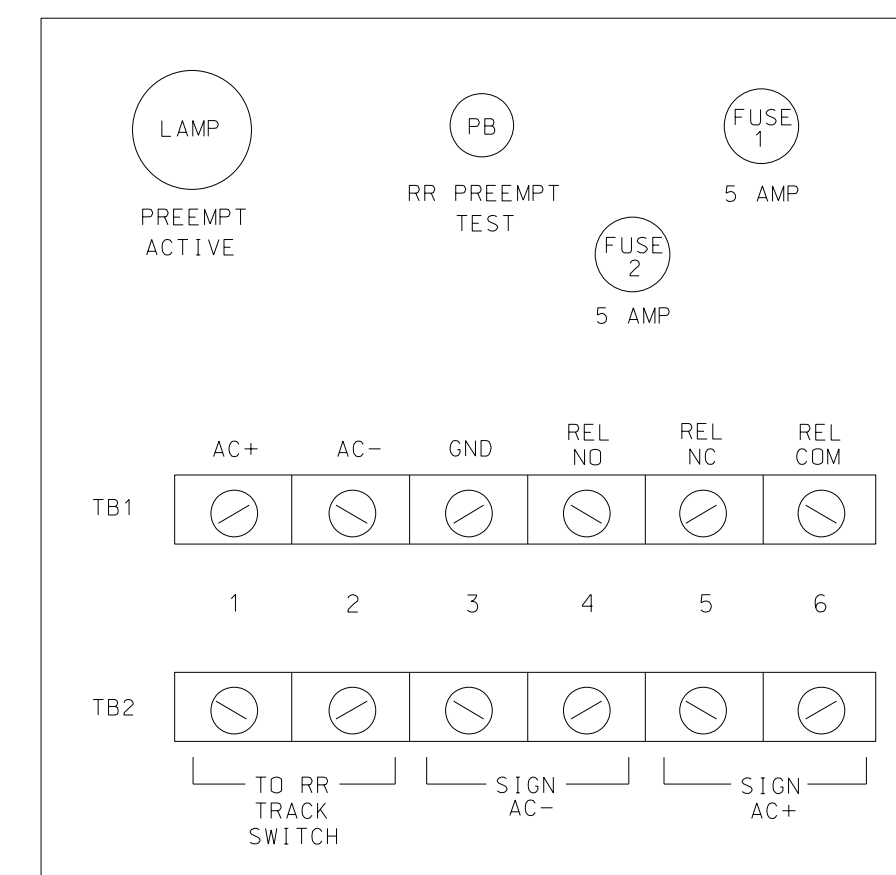

PREEMPT 2 AC ISOLATOR (MODEL 252) OUTPUT PROGRAMMING DETAIL

(set DIP switches as shown below)

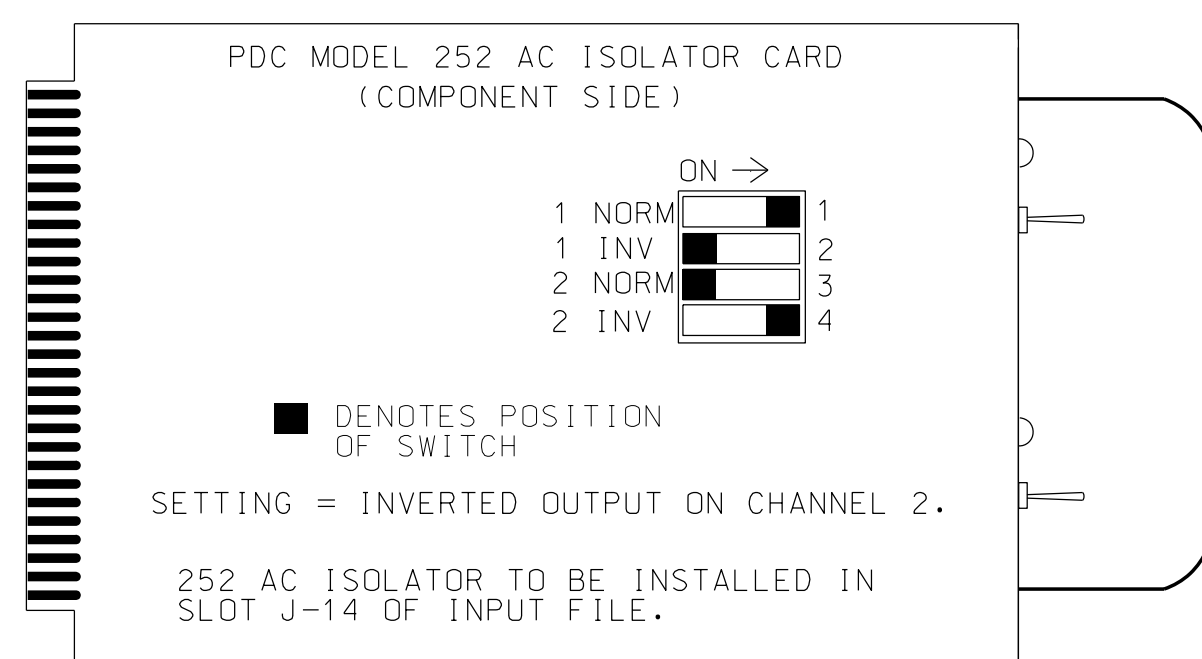

NOTE: IF ANOTHER MANUFACTURER TYPE OF AC ISOLATOR IS USED, OUTPUT PROGRAMMING IS LIKELY NOT TO EQUATE TO THAT SHOWN ABOVE.

THIS ELECTRICAL DETAIL IS FOR THE SIGNAL DESIGN: 01-0010
DESIGNED: FEBRUARY 2018
SEALED: 08/22/2018
REVISED: N/A

Electrical Detail - Sheet 2 of 4

ELECTRICAL AND PROGRAMMING DETAILS FOR:

Prepared for the Offices of:

DRMP
DRMP, Inc.
8000 Regency Parkway, Suite 175
Cary, NC 27519
NC License No. C-2215 (019) 650-1038

US 158 (Elizabeth Street) at Water Street	
Division 1 Pasquotank County Elizabeth City	
PLAN DATE: February 2018	REVIEWED BY: AJ Davis
PREPARED BY: DJ White	REVIEWED BY: LM Moon
REVISIONS	INIT. DATE

DOCUMENT NOT CONSIDERED FINAL UNLESS ALL SIGNATURES COMPLETED

SEAL

DocuSigned by:
Lisa M. Moon 9/20/2018
SIC#5882300421 DATE
SIC INVENTORY NO. 01-0010

ECONOLITE ASC/3-2070 EMERGENCY VEHICLE PREEMPT

PROGRAMMING DETAIL

(program controller as shown)

1. From Main Menu select 4. PREEMPTOR/TSP
2. From PREEMPTOR/TSP/SCP Submenu select 1. PREEMPT PLAN 1-10

Place cursor in [] next to Preempt Plan and press 4. Then press the right cursor arrow and toggle the controller to YES. Next cursor down. This will select Emergency Vehicle Preempt #4.

Place cursor in [] next to Preempt Plan and press 6. Then press the right cursor arrow and toggle the controller to YES. Next cursor down. This will select Emergency Vehicle Preempt #6.

```

PREEMPT PLAN [ 4 ]  ENABLE...YES
VEH/PED 1 2 3 4 5 6 7 8 9 0 1 2 3 4 5 6
OVERLAP A B C D E F G H I J K L M N O P
TRKCLR V . . . . .
TRKCLR O . . . . .
ENA TRL . . . . .
DWEL VEH X . . . . X . . . . .
DWEL PED . . . . .
DWEL OLPF1 . . . . .
CYC VEH . . . . .
CYC PED . . . . .
CYC OLP . . . . .
EXIT PH . X . . . X . . . . .
EXIT CAL . . . . .
SP FUNC . . . . .

ENABLE... YES|PMT OVRIDE..|INTERLOCK. NO
DET LOCK... XIDELAY.. 0|INHIBIT... 0
OVERIDE FL. |DURATION 0|CLR-GRN... NO
TERM OLP. NOIPC>YEL NO|TERM PH NO
PED DARK.. NO|TC RESRV NO|DWELL FL OFF
LINK PMT....O|X FLCOLR REDI|EXIT OPT. OFF
X TMG PLN...O|IRE-SERV.. 0|FLT TYPE.HARD
FREE DUR PMT|R1 NO|R2 NO|R3 NO|R4 NO
--TIMING----WALK|PED CLIMN GRI YELI RED
ENTRANCE TM. 255| 255| 1|25.5|25.5
-----MIN GRI|EXT GRIMX GRI YELI RED
TRACK CLEAR 0| 0| 0|25.5|25.5
-----MIN DL|PMTTEXTIMX TMI YELI RED
DWL/CYC-EXIT 10| 2.0| 120|25.5|25.5
PMT ACTIVE OUT..ON PMT ACT DWELL...NO
OTHER - PRI PMT.OFF NON-PRI PMT....OFF
INH EXT TIME... 0.0 PED PR RETURN...OFF
PRIORITY RETURN.OFF QUEUE DELAY.... OFF
COND DELAY.....OFF

PHASES 1 2 3 4 5 6 7 8
PR RTN% 0 0 0 0 0 0 0 0
PHASES 9 10 11 12 13 14 15 16
PR RTN% 0 0 0 0 0 0 0 0
    
```

```

PREEMPT PLAN [ 6 ]  ENABLE...YES
VEH/PED 1 2 3 4 5 6 7 8 9 0 1 2 3 4 5 6
OVERLAP A B C D E F G H I J K L M N O P
TRKCLR V . . . . .
TRKCLR O . . . . .
ENA TRL . . . . .
DWEL VEH . . . . . X . . . . .
DWEL PED . . . . .
DWEL OLP . . . . .
CYC VEH . . . . .
CYC PED . . . . .
CYC OLP . . . . .
EXIT PH . X . . . X . . . . .
EXIT CAL . . . . .
SP FUNC . . . . .

ENABLE... YES|PMT OVRIDE..|INTERLOCK. NO
DET LOCK... XIDELAY.. 0|INHIBIT... 0
OVERIDE FL. |DURATION 0|CLR-GRN... NO
TERM OLP. NOIPC>YEL NO|TERM PH NO
PED DARK.. NO|TC RESRV NO|DWELL FL OFF
LINK PMT....O|X FLCOLR REDI|EXIT OPT. OFF
X TMG PLN...O|IRE-SERV.. 0|FLT TYPE.HARD
FREE DUR PMT|R1 NO|R2 NO|R3 NO|R4 NO
--TIMING----WALK|PED CLIMN GRI YELI RED
ENTRANCE TM. 255| 255| 1|25.5|25.5
-----MIN GRI|EXT GRIMX GRI YELI RED
TRACK CLEAR 0| 0| 0|25.5|25.5
-----MIN DL|PMTTEXTIMX TMI YELI RED
DWL/CYC-EXIT 10| 2.0| 120|25.5|25.5
PMT ACTIVE OUT..ON PMT ACT DWELL...NO
OTHER - PRI PMT.OFF NON-PRI PMT....OFF
INH EXT TIME... 0.0 PED PR RETURN...OFF
PRIORITY RETURN.OFF QUEUE DELAY.... OFF
COND DELAY.....OFF

PHASES 1 2 3 4 5 6 7 8
PR RTN% 0 0 0 0 0 0 0 0
PHASES 9 10 11 12 13 14 15 16
PR RTN% 0 0 0 0 0 0 0 0
    
```

ECONOLITE ASC/3-2070 PREEMPT FILTERING PROGRAMMING DETAIL

(program controller as shown)

1. From Main Menu select 4. PREEMPTOR/TSP
2. From PREEMPT/TSP/SCP Submenu select 2. ENABLE PREEMPT FILTERING & TSP/SCP

```

ENABLE PREEMPT FILTERING & TSP/SCP
FILTERED SOLID PULSING
INPUT 1 ...BYPASSED...BYPASSED..
2 ..PREEMPT 2. ...BYPASSED..
3 ..PREEMPT 3. ...BYPASSED..
4 ...BYPASSED...BYPASSED..
5 ..PREEMPT 5. ...BYPASSED..
6 ...BYPASSED...BYPASSED..
7 ..BYPASSED...BYPASSED..
8 ...BYPASSED...BYPASSED..
9 ..BYPASSED...BYPASSED..
10 ...BYPASSED...BYPASSED..
    
```

THIS ELECTRICAL DETAIL IS FOR THE SIGNAL DESIGN: 01-0010
DESIGNED: FEBRUARY 2018
SEALED: 08/22/2018
REVISED: N/A

ECONOLITE ASC/3-2070 OVERLAP PROGRAMMING DETAIL

(program controller as shown)

1. From Main Menu select 2. CONTROLLER
2. From CONTROLLER Submenu select 2. VEHICLE OVERLAPS

OVERLAP A

Select TMG VEH OVLP [A] and 'PPLT FYA'

```

TMG VEH OVLP...[A] TYPE: .....PPLT FYA
PROTECTED LEFT TURN.... PHASE 1
OPPOSING THROUGH..... PHASE 2

FLASHING ARROW OUTPUT.....CH9 ISOLATE
DELAY START OF: FYA..0.0 CLEARANCE..0.0
ACTION PLAN SF BIT DISABLE..... 0

Toggle Once
    
```

↓

OVERLAP B

Select TMG VEH OVLP [B] and 'NORMAL'

```

TMG VEH OVLP...[B] TYPE: .....NORMAL
PHASES 1 2 3 4 5 6 7 8 9 0 1 2 3 4 5 6
INCLUDED X . . . . .

LAG GRN 0.0 YEL 0.0 RED 0.0

END PROGRAMMING
    
```

Electrical Detail - Sheet 3 of 4

<p>ELECTRICAL AND PROGRAMMING DETAILS FOR:</p> <p style="font-size: small;">Prepared for the Offices of:</p> <p style="font-size: x-small;">DRMP, Inc. 8000 Regency Parkway, Suite 175 Cary, NC 27519 NC License No. C-2215 (019) 650-1038</p>	<p>US 158 (Elizabeth Street) at Water Street</p> <p>Division 1 Pasquotank County Elizabeth City</p> <table border="1" style="width: 100%; border-collapse: collapse;"> <tr> <td>PLAN DATE: February 2018</td> <td>REVIEWED BY: AJ Davis</td> </tr> <tr> <td>PREPARED BY: DJ White</td> <td>REVIEWED BY: LM Moon</td> </tr> </table> <table border="1" style="width: 100%; border-collapse: collapse;"> <tr> <th>REVISIONS</th> <th>INIT.</th> <th>DATE</th> </tr> <tr> <td> </td> <td> </td> <td> </td> </tr> </table>	PLAN DATE: February 2018	REVIEWED BY: AJ Davis	PREPARED BY: DJ White	REVIEWED BY: LM Moon	REVISIONS	INIT.	DATE				<p style="text-align: center; font-weight: bold;">DOCUMENT NOT CONSIDERED FINAL UNLESS ALL SIGNATURES COMPLETED</p> <p style="text-align: center; font-size: x-small;">SEAL</p> <p style="font-size: x-small;">DocuSigned by: <i>Lisa M. Moon</i> 9/20/2018 sccs888030421 DATE</p> <p style="font-size: x-small;">SIG. INVENTORY NO. 01-0010</p>
PLAN DATE: February 2018	REVIEWED BY: AJ Davis											
PREPARED BY: DJ White	REVIEWED BY: LM Moon											
REVISIONS	INIT.	DATE										

NOTES

- The International Fiber Systems DT1825 is an 8-channel contact mapping transmitter capable of transmitting up to eight contact closures over an optical fiber.
- * Power connections are with the supplied 12 Volt DC Plug-in Power Supply.
- Relay 'K1' is a SPDT with a 120VAC coil. (DOT Material No. 625028600) (P&B# KRP5AG)
- RCN is valued at .1 microFarad, 100 Ohm. (DOT Material No. 106018075)
- Relocate existing equipment from existing cabinet to new cabinet.

**PREEMPT STATUS OUTPUT PROGRAMMING
NOTES FOR 01-0010 I/O PIN REMAPPING**

In order for the bridge preempt call to be relayed to 01-0008 and 01-0009 make the following programming changes to Output No. 33 in the controller for 01-0010:

- Change the function of C1 pin 35 to be an output for the bridge preempt. This is accomplished by the following:
 - Run the Configurator utility. Load a file as the Current DB.
 - Choose either the C1-out tab or C1-in tab to change the I/O mapping as needed. Use the drop down list within the program to select the assigned function for the pins shown below.
 - Save the database file and download it to the controller.

C1 PIN #	DEFAULT FUNCTION	ASSIGNED FUNCTION
----------	------------------	-------------------

PIN 35-PED 2 YELLOW → PREEMPT 2 STATUS

NOTE: TO RELAY BRIDGE PREEMPT TO CABINETS 01-0008 & 01-0009

NOTE: The steps below can be used to view changes to I/O pins within the controller. Any I/O pins that have been remapped will display and show their default function in addition to the current assigned function.

- From Main Menu select **7. STATUS DISPLAY**
- From STATUS DISPLAY Submenu select **8. INPUTS/OUTPUTS**
- From INPUT/OUTPUT Submenu select **9. I/O DIFFERENCES**

- If field terminal 114 has a conflict monitor wire attached, remove, tape, and label wire.
- To prevent a 'phantom' (or false) conflict, install a load resistor on field terminal 115 (Ped 2 Walk) as shown on sheet 1.
- Install a loadswitch in Output File Slot S3.

PHASE 2 PED YELLOW = PREEMPT 2 STATUS OUTPUT (OUTPUT 33)

**FIBER OPTIC CONTACT CLOSURE
TRANSMITTER #1 WIRING FOR 01-0010**

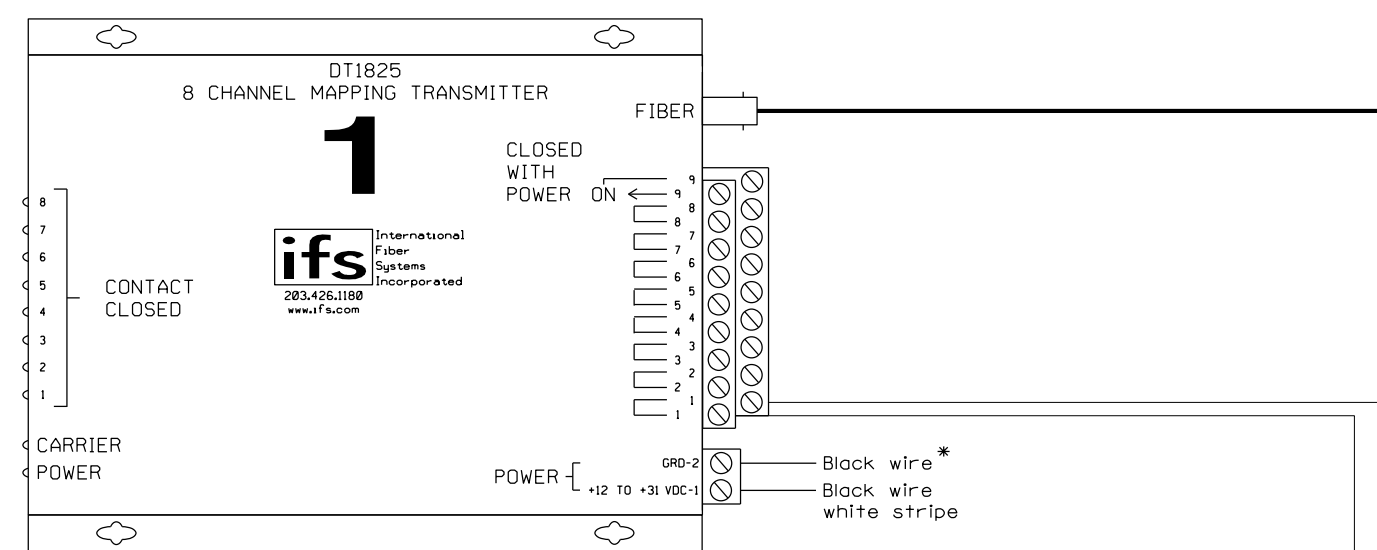

NOTE: WHEN CONTACTS CLOSE ON RELAY K1, BRIDGE PREEMPT CALL WILL BE GENERATED AT 01-0008 AND 01-0009.

**FIBER OPTIC CONTACT CLOSURE
TRANSMITTER #2 WIRING FOR 01-0010**

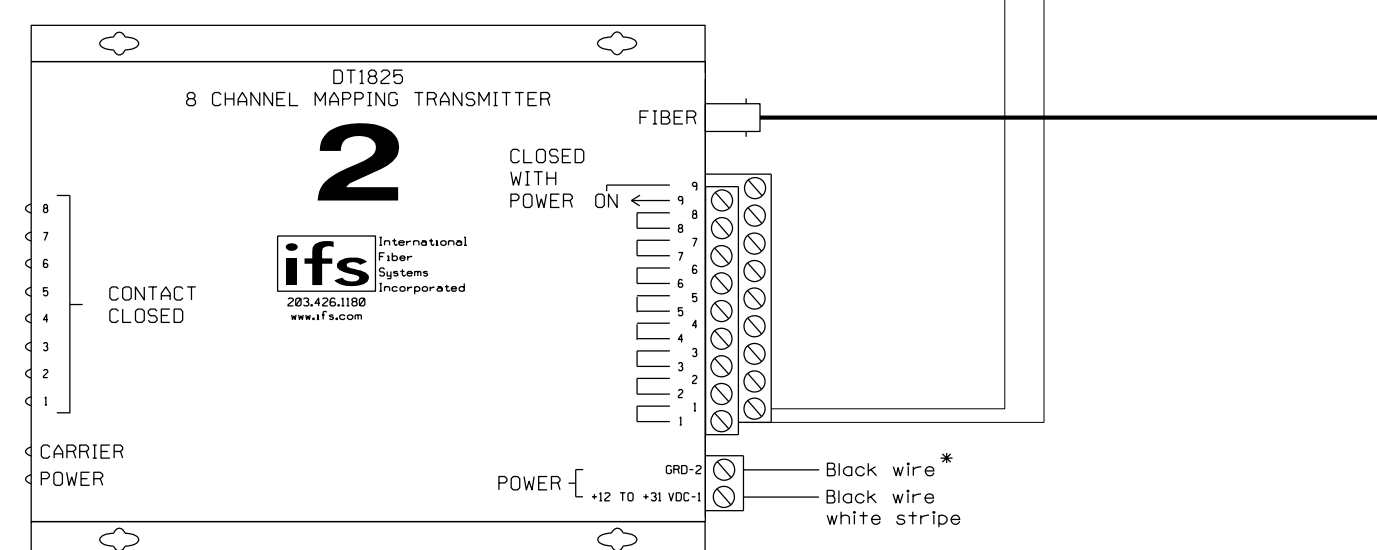

THIS ELECTRICAL DETAIL IS FOR THE SIGNAL DESIGN: 01-0010
DESIGNED: FEBRUARY 2018
SEALED: 08/22/2018
REVISED: N/A

FIBER OPTIC RECEIVER WIRING LOCATED AT 01-0008

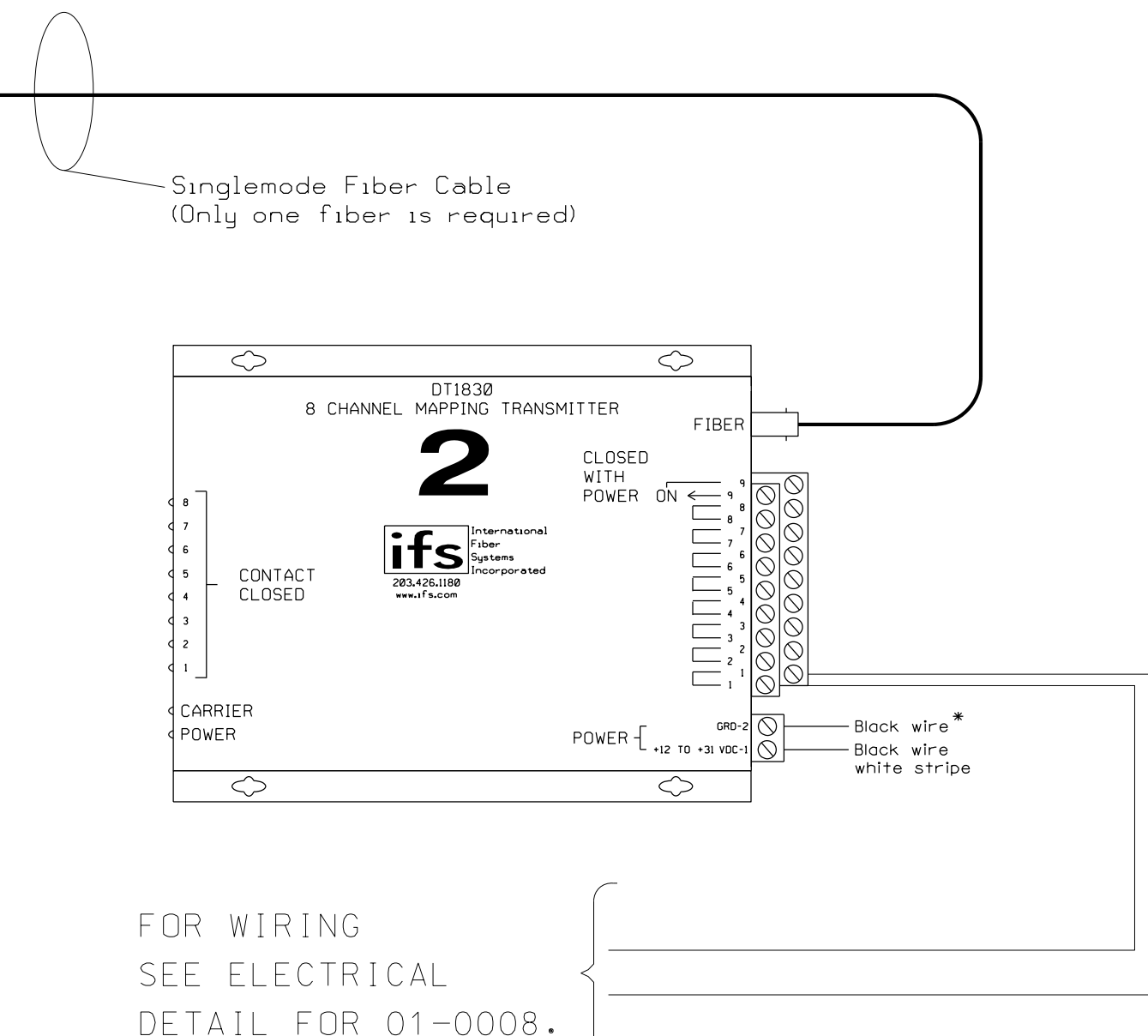

FIBER OPTIC RECEIVER WIRING LOCATED AT 01-0009

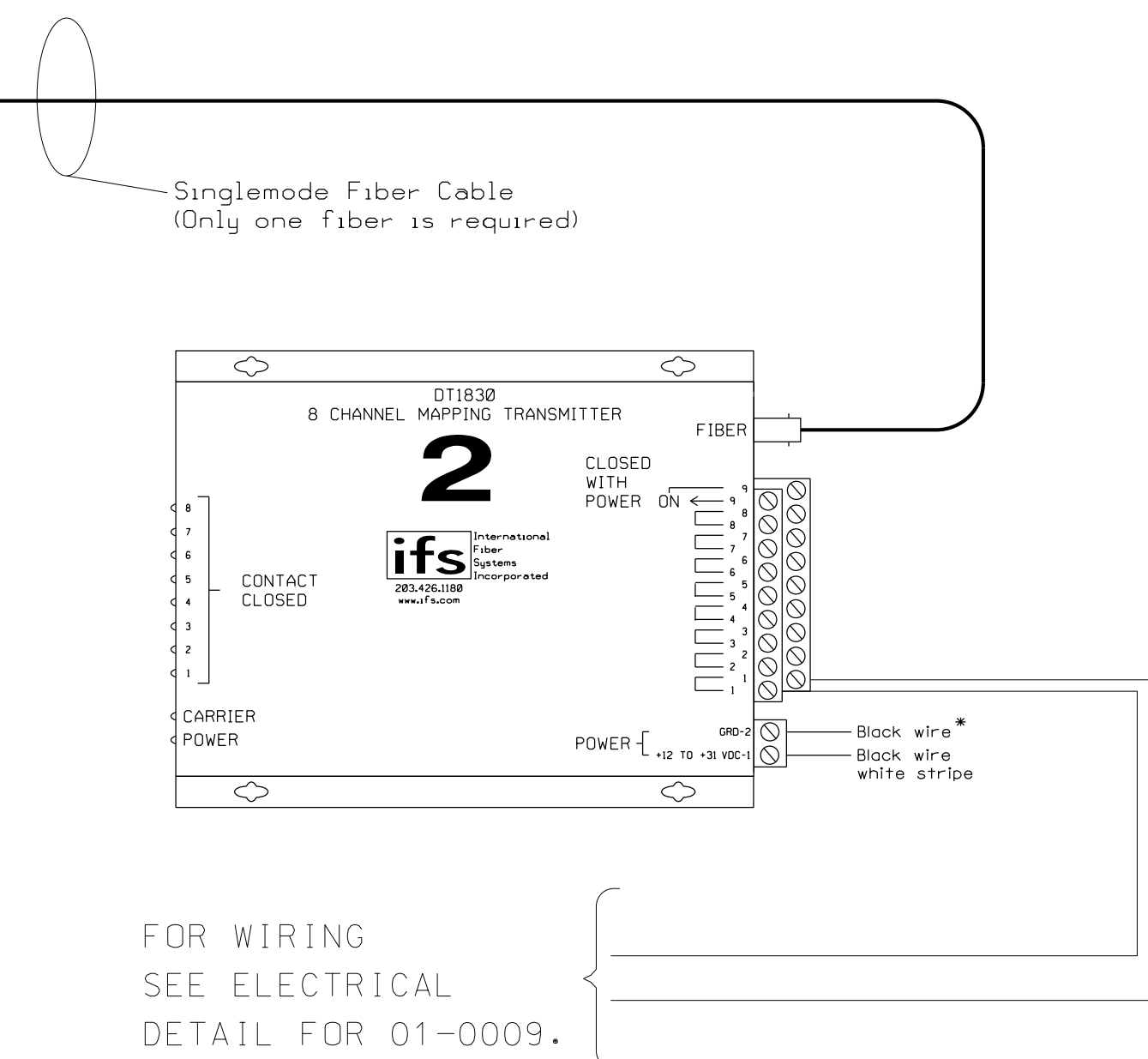

Electrical Detail - Sheet 4 of 4

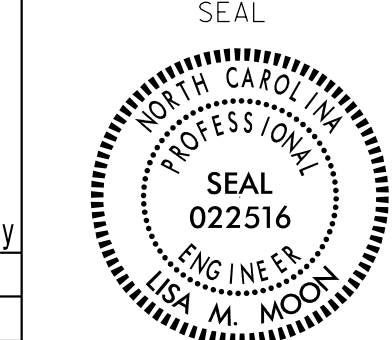
<p>Electrical and Programming Details For:</p> <p>Prepared for the Offices of:</p>  <p>DRMP, Inc. 8000 Regency Parkway, Suite 175 Charlotte, NC 27518 NC License No. C-2215 (019) 650-1038</p>	<p>US 158 (Elizabeth Street) at Water Street</p> <p>Division 1 Pasquotank County Elizabeth City</p> <p>PLAN DATE: February 2018 REVIEWED BY: AJ Davis</p> <p>PREPARED BY: DJ White REVIEWED BY: LM Moon</p>	<p>DOCUMENT NOT CONSIDERED FINAL UNLESS ALL SIGNATURES COMPLETED</p> <p>SEAL</p>  <p>SEAL 022516</p> <p>DocuSigned by: Lisa M. Moon 9/20/2018</p> <p>SIG. INVENTORY NO. 01-0010</p>								
	<p>REVISIONS</p> <table border="1"> <tr> <th>NO.</th> <th>DESCRIPTION</th> <th>INIT.</th> <th>DATE</th> </tr> <tr> <td> </td> <td> </td> <td> </td> <td> </td> </tr> </table>	NO.	DESCRIPTION	INIT.	DATE					<p>DATE</p>
NO.	DESCRIPTION	INIT.	DATE							

20-SEP-2018 10:49 R:\05942\51001\5\K\51001\5\K\51001-0010-20180823e.dgn Jmoon AT CAR-LMCDN1-W7

ECONOLITE ASC/3-2070 PEDESTRIAN DETECTOR PHASE ASSIGNMENT PROGRAMMING DETAIL

(program controller as shown)

- From Main Menu select **6. DETECTORS**
- From DETECTOR Submenu select **3. PED DETECTOR INPUT ASSIGNMENT**
- Press the TOGGLE key to select **ECONOLITE MODE** and press ENTER.

PED DET PHASE	ASSIGNMENT MODE	ECONOLITE v
PHASE	1 2 3 4 5 6 7 8 9 0 1 2 3 4 5 6	
D	1 X	
E	2 . X	
T	3 . . X	
E	4 . . . X	
C	5 X	
T	6 X	
D	7 X	
R	8 . . . X . . . X	
	9 X	
	10 X	
	11 X	
	12 X	
	13 X	
	14 X	
	15 X	
	16 X	

“.” = No assignment, disabled
 X = Assigns Pedestrian Push Button (PPB) to call the phase or phases
 2 = Call for Ped timing 2
 B = Allows for the PPB to call for Min Green 2 (BIKE GREEN)

COUNTDOWN PEDESTRIAN SIGNAL OPERATION

Countdown Ped Signals are required to display timing only during Ped Clearance Interval. Consult Ped Signal Module user's manual for instructions on selecting this feature.

ECONOLITE ASC/3-2070 OVERLAP PROGRAMMING DETAIL

(program controller as shown)

- From Main Menu select **2. CONTROLLER**
- From CONTROLLER Submenu select **2. VEHICLE OVERLAPS**

OVERLAP A

Select TMG VEH OVLP [A] and 'OTHER/ECONOLITE'

TMG VEH OVLP... [A] TYPE:	OTHER/ECONOLITE
PHASES	1 2 3 4 5 6 7 8 9 0 1 2 3 4 5 6
INCLUDED	. X
PROTECT
PED PRTC
NOT OVLP
FLSH GRN	. 1
LAG X PH
LAG 2 PH
LAG GRN 0.0 YEL 0.0 RED 0.0 ADV GRN 0.0	

Toggle Twice

OVERLAP C

Select TMG VEH OVLP [C] and 'PPLT FYA'

TMG VEH OVLP... [C] TYPE: PPLT FYA
PROTECTED LEFT TURN....	PHASE 5
OPPOSING THROUGH.....	PHASE 6
FLASHING ARROW OUTPUT.....	CH11 ISOLATE
DELAY START OF: FYA..0.0 CLEARANCE..0.0	
ACTION PLAN SF BIT DISABLE.....	0

END PROGRAMMING

THIS ELECTRICAL DETAIL IS FOR
 THE SIGNAL DESIGN: 01-0011
 DESIGNED: MARCH 2018
 SEALED: 08/22/2018
 REVISED: N/A

Electrical Detail - Sheet 2 of 2

DOCUMENT NOT CONSIDERED FINAL UNLESS ALL SIGNATURES COMPLETED

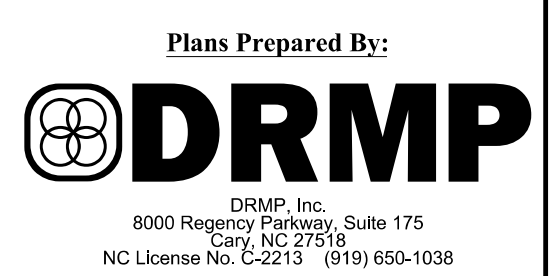

ELECTRICAL AND PROGRAMMING DETAILS FOR:	
SR 1268 (Water Street) at Main Street	
Division 1 Pasquotank County Elizabeth City	
PLAN DATE: March 2018	REVIEWED BY: AJ Davis
PREPARED BY: DJ White	REVIEWED BY: LM Moon
REVISIONS	INIT. DATE

SEAL

STATE OF NORTH CAROLINA PROFESSIONAL ENGINEER

SEAL 022516

LISA M. MOON

DocuSigned by: Lisa M. Moon 9/20/2018

SIG. INVENTORY NO. 01-0011

20-SEP-2018 10:49
 R:\415942\51\001\5\Kees\gnw\1r\mg401-0011-20180822e.dgn
 lmoon AT CAR-LMCDM-W7

PHASING DIAGRAM

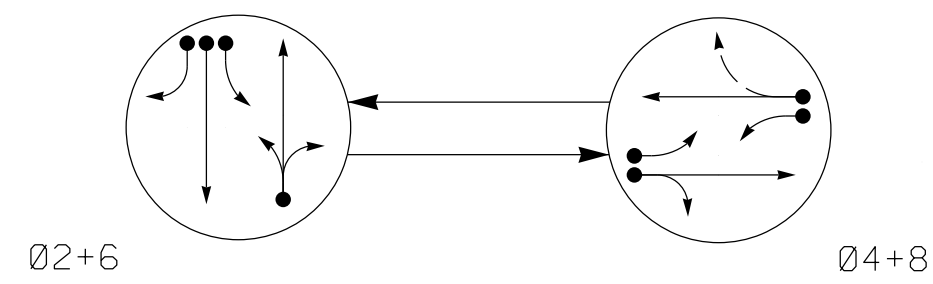

PHASING DIAGRAM DETECTION LEGEND

- ← DETECTED MOVEMENT
- ← UNDETECTED MOVEMENT (OVERLAP)
- ← UNSIGNALIZED MOVEMENT
- ← --- → PEDESTRIAN MOVEMENT

SIGNAL FACE	PHASE		
	02+6	04+8	FLASH
21, 22	G	R	Y
41, 42	R	G	R
61, 62	G	R	Y
81, 82	R	G	R

SIGNAL FACE I.D.

All Heads L.E.D.

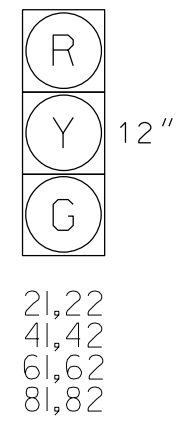

ASC/3 DETECTOR INSTALLATION CHART											
DETECTOR				PROGRAMMING							
LOOP	SIZE (FT)	DISTANCE FROM STOPBAR (FT)	TURNS	NEW LOOP	PHASE	CALLING	EXTEND TIME	DELAY TIME	USE ADDED INITIAL	TYPE	LOOP NEW CARD
2A	6X40	0	2-4-2	-	2	Yes	-	-	-	S	- X
4A	6X40	0	2-4-2	-	4	Yes	-	-	-	S	- X
4B	6X40	0	2-4-2	-	4	Yes	-	10	-	S	- X
6A	6X40	0	2-4-2	-	6	Yes	-	3	-	S	- X
6B	6X40	0	2-4-2	-	6	Yes	-	-	-	S	- X
6C	6X40	0	2-4-2	-	6	Yes	-	-	-	S	- X
8A	6X40	0	2-4-2	-	8	Yes	-	-	-	S	- X
8B	6X40	0	2-4-2	-	8	Yes	-	-	-	S	- X
S1	6X6	+165	4	X	-	Yes	-	-	-	N	X X
S2	6X6	+165	4	X	-	Yes	-	-	-	N	X X

2 Phase Fully Actuated (Elizabeth City Signal System)

NOTES

- Refer to "Roadway Standard Drawings NCDOT" dated January 2018 and "Standard Specifications for Roads and Structures" dated January 2018.
- Do not program signal for late night flashing operation unless otherwise directed by the Engineer.
- Set all detector units to presence mode.
- Locate new cabinet so as not to obstruct sight distance of vehicles turning right on red.
- Pavement markings are existing.
- Maximum times shown in timing chart are for free-run operations only. Coordinated signal system timing values supersede these values.

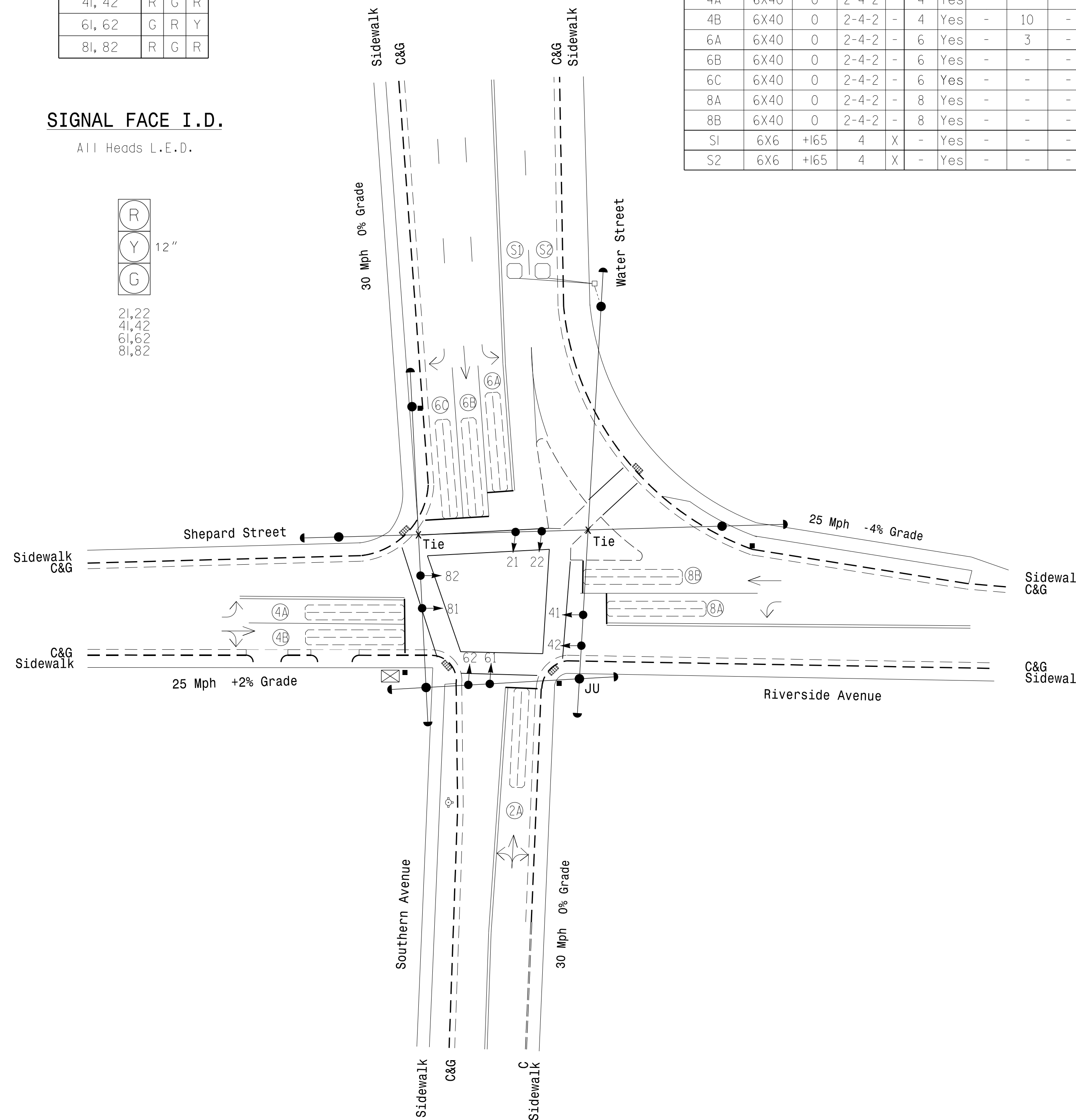

FEATURE	PHASE			
	2	4	6	8
Min Green *	10	7	10	7
Walk *	0	0	0	0
Ped Clear	0	0	0	0
Veh. Extension *	2.0	2.0	2.0	2.0
Max 1 *	60	30	60	30
Yellow	3.5	3.1	3.5	3.4
Red Clear	1.4	1.8	1.6	1.5
Actuations B4 Add *	-	-	-	-
Seconds /Actuation *	-	-	-	-
Max Initial *	-	-	-	-
Time Before Reduction *	-	-	-	-
Time To Reduce *	-	-	-	-
Minimum Gap	-	-	-	-
Locking Detector	-	-	-	-
Recall Position	VEH. RECALL	-	VEH. RECALL	-
Dual Entry	-	X	-	X
Simultaneous Gap	X	X	X	X

* These values may be field adjusted. Do not adjust Min Green and Extension times for phases 2 and 6 lower than what is shown. Min Green for all other phases should not be lower than 4 seconds.

LEGEND	
PROPOSED	EXISTING
○ → Traffic Signal Head	● → N/A
○ → Modified Signal Head	○ → N/A
○ → Sign	○ → N/A
○ → Pedestrian Signal Head With Push Button & Sign	○ → N/A
○ → Signal Pole with Guy	○ → N/A
○ → Signal Pole with Sidewalk Guy	○ → N/A
□ → Inductive Loop Detector	□ → N/A
□ → Controller & Cabinet	□ → N/A
□ → Junction Box	□ → N/A
--- 2-in Underground Conduit	--- 2-in Underground Conduit
N/A Right of Way	N/A Right of Way
→ Directional Arrow	→ Directional Arrow
N/A Fire Hydrant	⊕ Fire Hydrant
N/A Curb Ramp	▤ Curb Ramp

Signal Upgrade

DOCUMENT NOT CONSIDERED FINAL UNLESS ALL SIGNATURES COMPLETED

Plans Prepared By:

DRMP, Inc.
8000 Regency Parkway, Suite 175
Cary, NC 27519
NC License No. C-2213 (919) 650-1038

SR 1164 (Southern Ave.) / SR 1164 (Water St.) at Shepard St./Riverside Ave.	
Division 1 Pasquotank County Elizabeth City	
PLAN DATE: February 2018	REVIEWED BY: AJ Davis
PREPARED BY: JA Le	REVIEWED BY: LM Moon
REVISIONS	INIT. DATE

DocuSigned by:
Lisa M. Moon
9/20/2018
SIC68803D0421
DATE
SIG. INVENTORY NO. 01-0012

20-SEP-2018 16:34 R:\415942\415942.dwg User: jlemon AT: CAR-LMCDN1-W7

