

*COVER WHEN DETOUR IS ACTIVE
 **PREVIOUSLY ERRECTED

MATCHLINE -Y- STA 47+00 SEE TMP-24

USE RDWY STD 1101.03 SHEET 1 FOR SIGNING AND DEVICES

-Y5- SR 2790
 ECKERSON RD

APPROVED: *Kevin W. Bisby*
 DATE: 3/31/2020

SEAL

DOCUMENT NOT CONSIDERED FINAL
 UNLESS ALL SIGNATURES COMPLETED

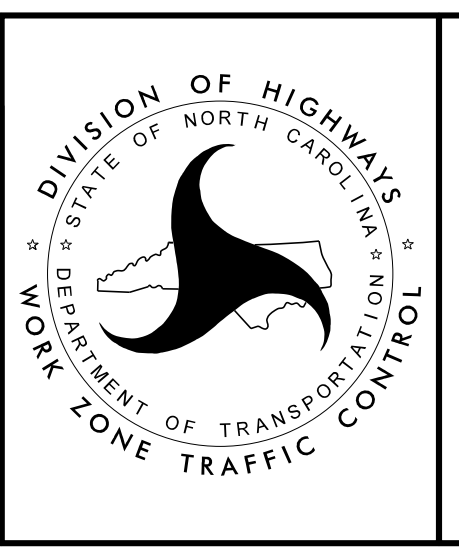

PHASE III - STEP 4

PROJ. REFERENCE NO. R - 4707	SHEET NO. TMP - 25
---------------------------------	-----------------------

RK&K
 P: (919) 578-8560
 8601 Six Forks Road, Forum 1, Suite 700
 Raleigh, North Carolina 27615-3960
 NC License No. F-0112
 Engineers | Construction Managers | Planners | Scientists
 www.rkk.com
 Responsive People | Creative Solutions

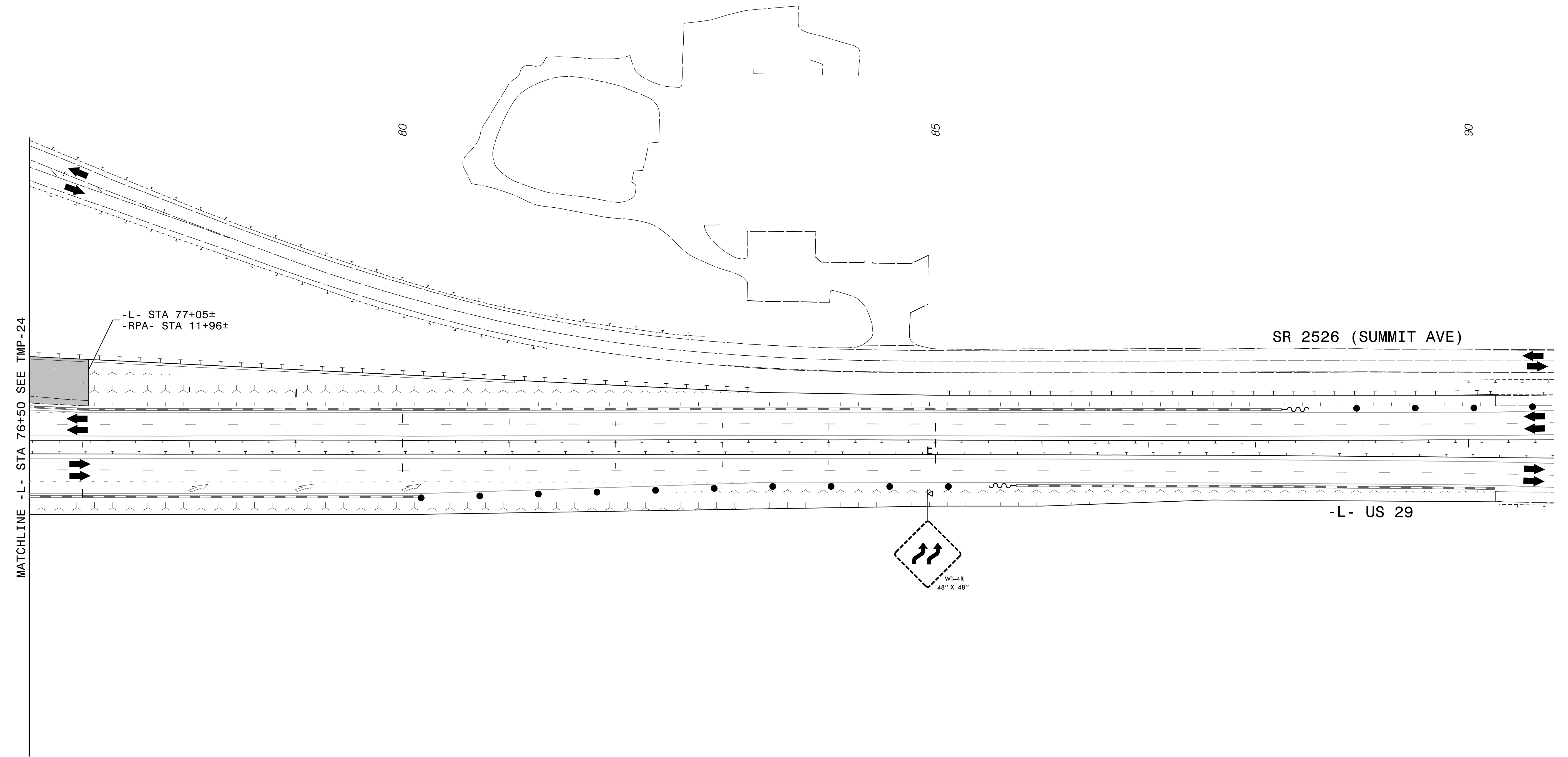
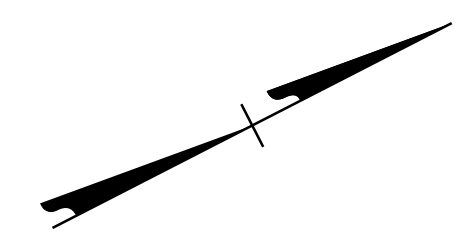

APPROVED: *Kevin W. Bisby*
DocuSigned by:
Kevin W. Bisby
3CE5C9A80F464B1...

DATE: 3/31/2020

SEAL

PROFESSIONAL ENGINEER
 KEVIN W. BISBY
 SEAL 21047
 NORTH CAROLINA

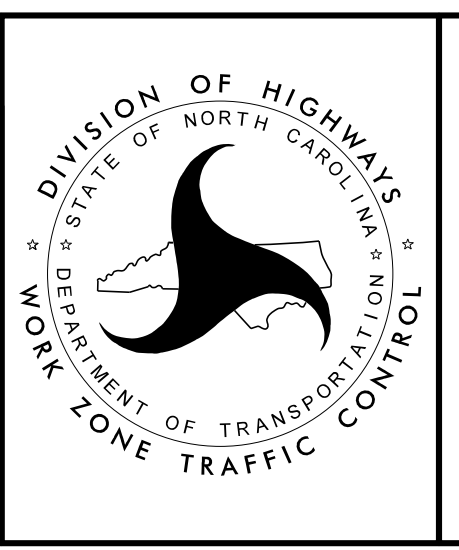

PHASE III - STEP 4

**DOCUMENT NOT CONSIDERED FINAL
UNLESS ALL SIGNATURES COMPLETED**

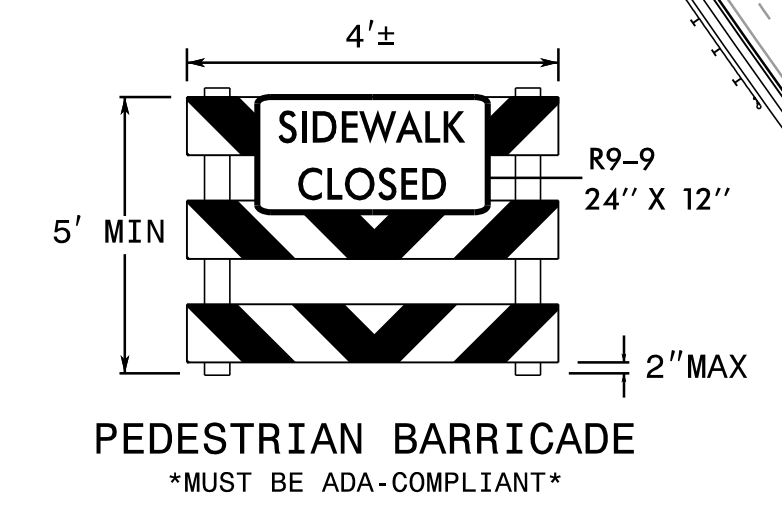
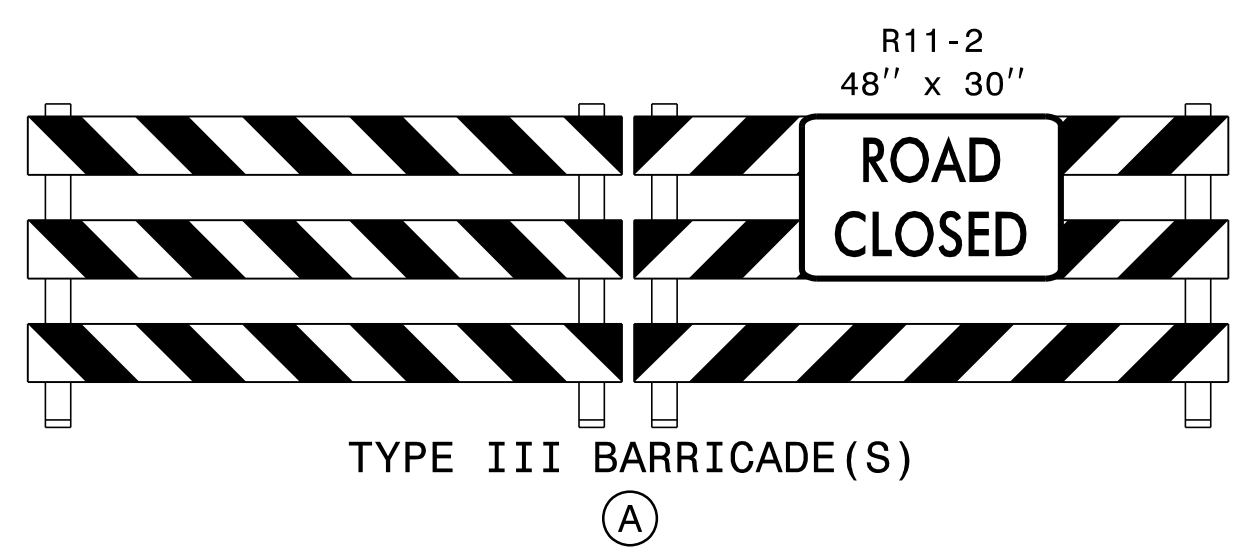

POSITIVE PROTECTION LOCATIONS	
①	-L- STA 64+28± 2' OFFSET FROM TRAVEL LANE
②	-L- STA 72+46± 2' OFFSET FROM TRAVEL LANE
③	-L- STA 72+94± 6' OFFSET FROM TRAVEL LANE
④	-L- STA 62+39± 10' OFFSET FROM TRAVEL LANE
⑤	-L- STA 63+35± 2' OFFSET FROM TRAVEL LANE
⑥	-L- STA 72+80± 2' OFFSET FROM TRAVEL LANE

ERECT SIGNS W23-2 (NEW TRAFFIC PATTERN) ON -L- US 29 AND -Y- REEDY FORK PKWY 500± IN ADVANCE OF THE PROJECT LIMIT OR AS DIRECTED BY THE ENGINEER. CHANGEABLE MESSAGE SIGNS SHALL BE DEPLOYED ON -L- US 29 INDICATING THE NEW TRAFFIC PATTERN AS DIRECTED BY THE ENGINEER.

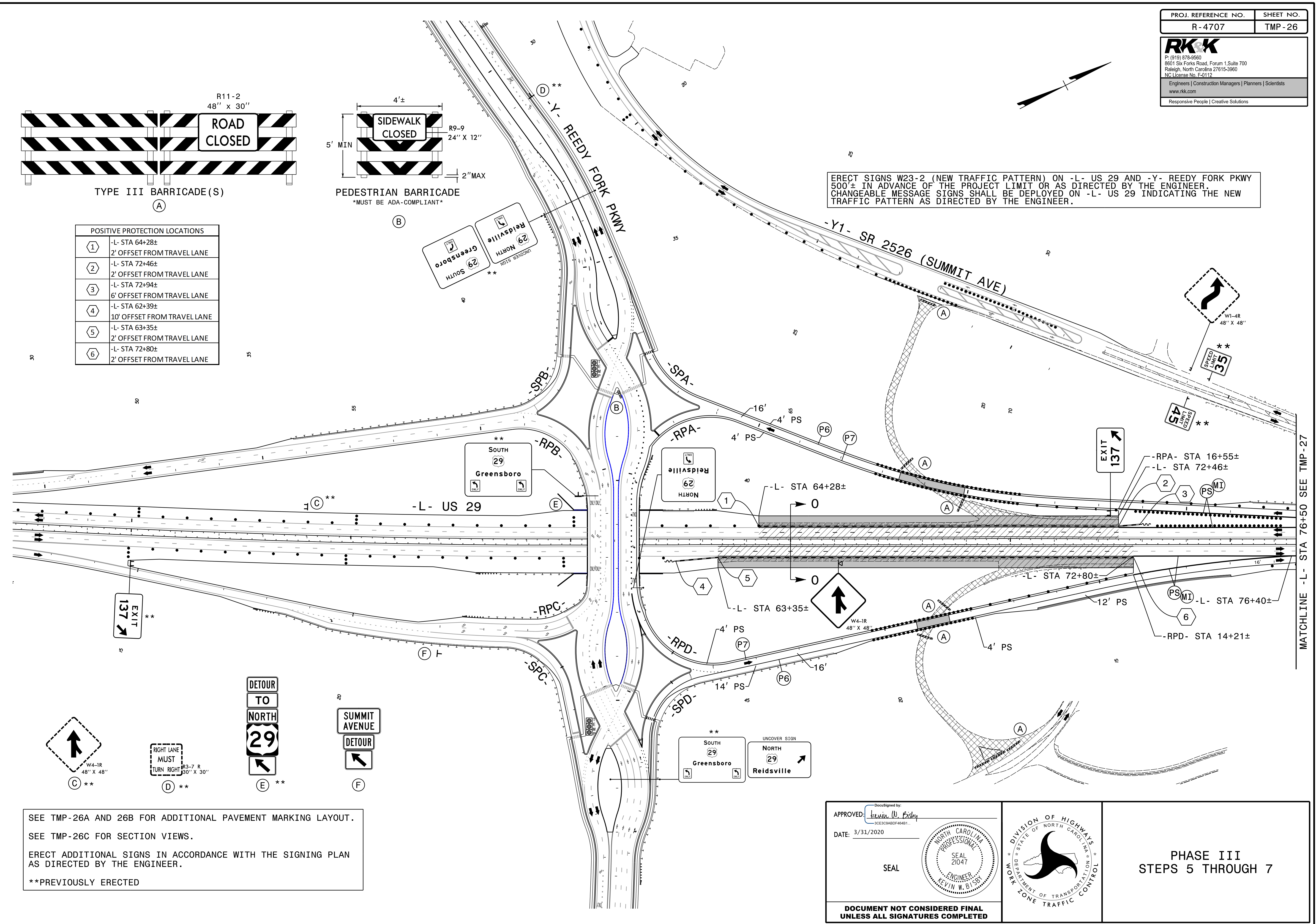

SEE TMP-26A AND 26B FOR ADDITIONAL PAVEMENT MARKING LAYOUT.
 SEE TMP-26C FOR SECTION VIEWS.
 ERECT ADDITIONAL SIGNS IN ACCORDANCE WITH THE SIGNING PLAN AS DIRECTED BY THE ENGINEER.
 **PREVIOUSLY ERECTED

APPROVED: *Kevin W. Bisby*
 DATE: 3/31/2020
 SEAL
 NORTH CAROLINA PROFESSIONAL ENGINEER
 SEAL 21047
 KEVIN W. BISBY

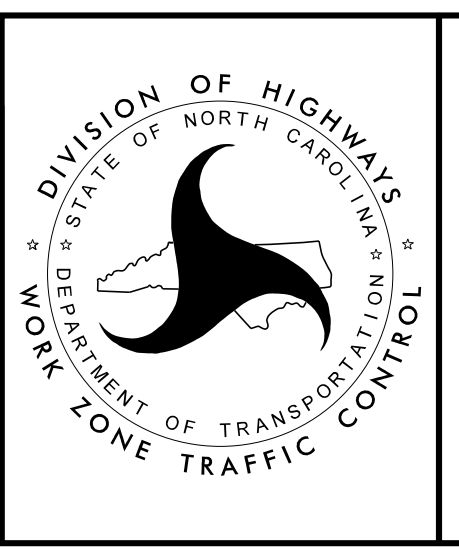

PHASE III
 STEPS 5 THROUGH 7

MATCHLINE -L- STA 76+50 SEE TMP-27

RKK
 P: (919) 878-8560
 8601 Six Forks Road, Forum 1, Suite 700
 Raleigh, North Carolina 27615-3960
 NC License No. F-0112
 Engineers | Construction Managers | Planners | Scientists
 www.rkk.com
 Responsive People | Creative Solutions

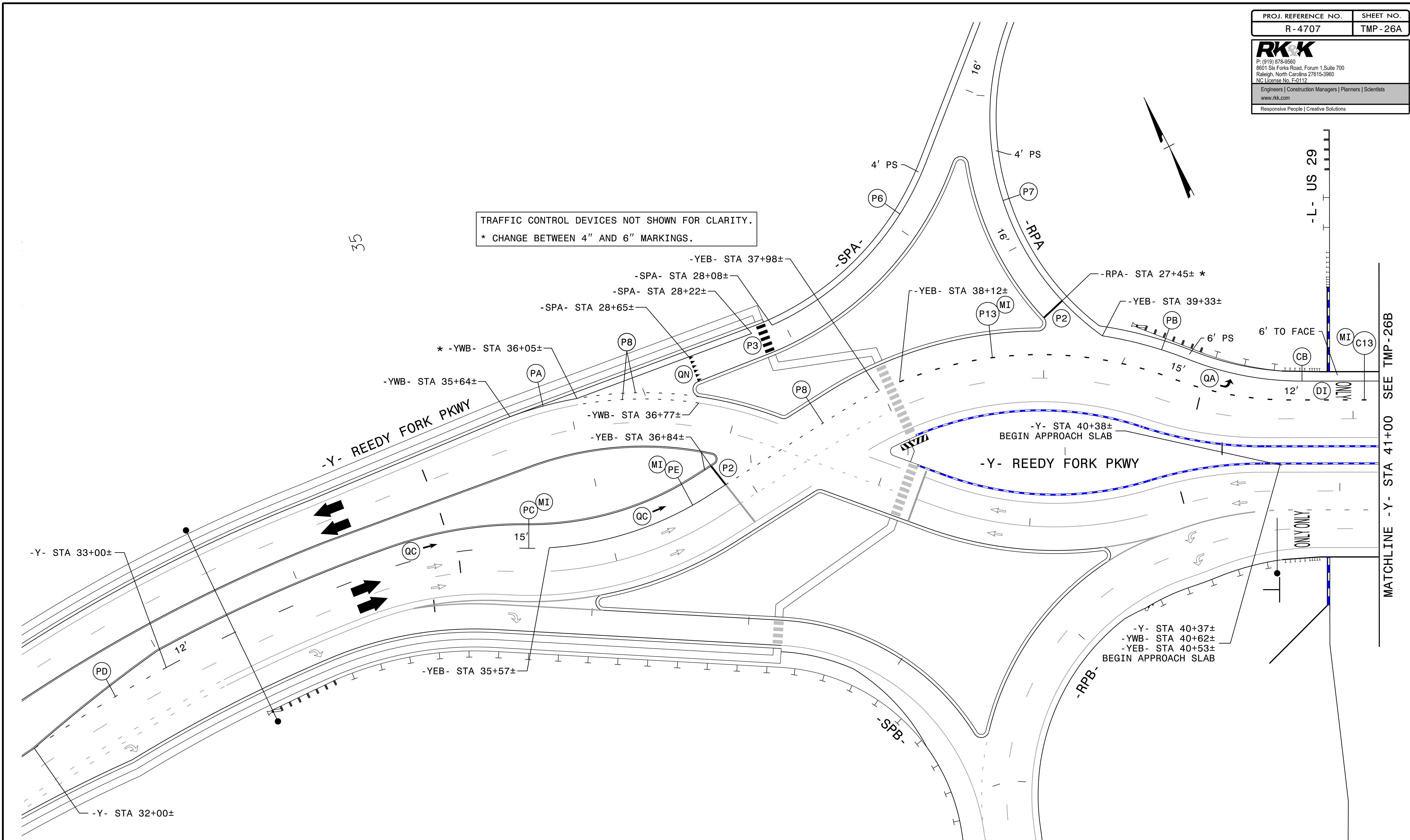

TRAFFIC CONTROL DEVICES NOT SHOWN FOR CLARITY.
 * CHANGE BETWEEN 4" AND 6" MARKINGS.

-L- US 29

MATCHLINE -Y- STA 41+00 SEE TMP-26B

APPROVED: *Kevin W. Bisby*
 DATE: 3/31/2020

SEAL

DOCUMENT NOT CONSIDERED FINAL
 UNLESS ALL SIGNATURES COMPLETED

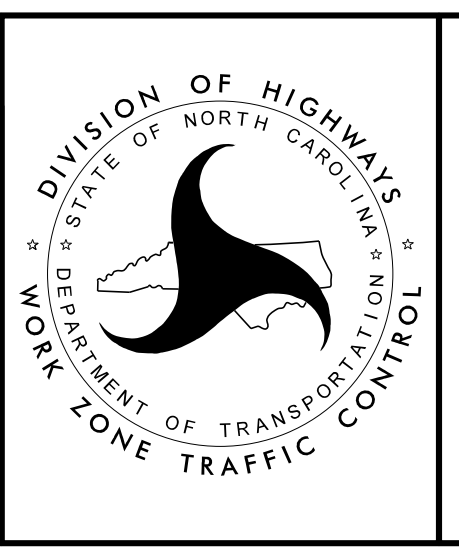

DIVISION OF HIGHWAYS
 STATE OF NORTH CAROLINA
 DEPARTMENT OF TRANSPORTATION
 WORK ZONE TRAFFIC CONTROL

PHASE III - STEP 5
 PAVEMENT MARKINGS

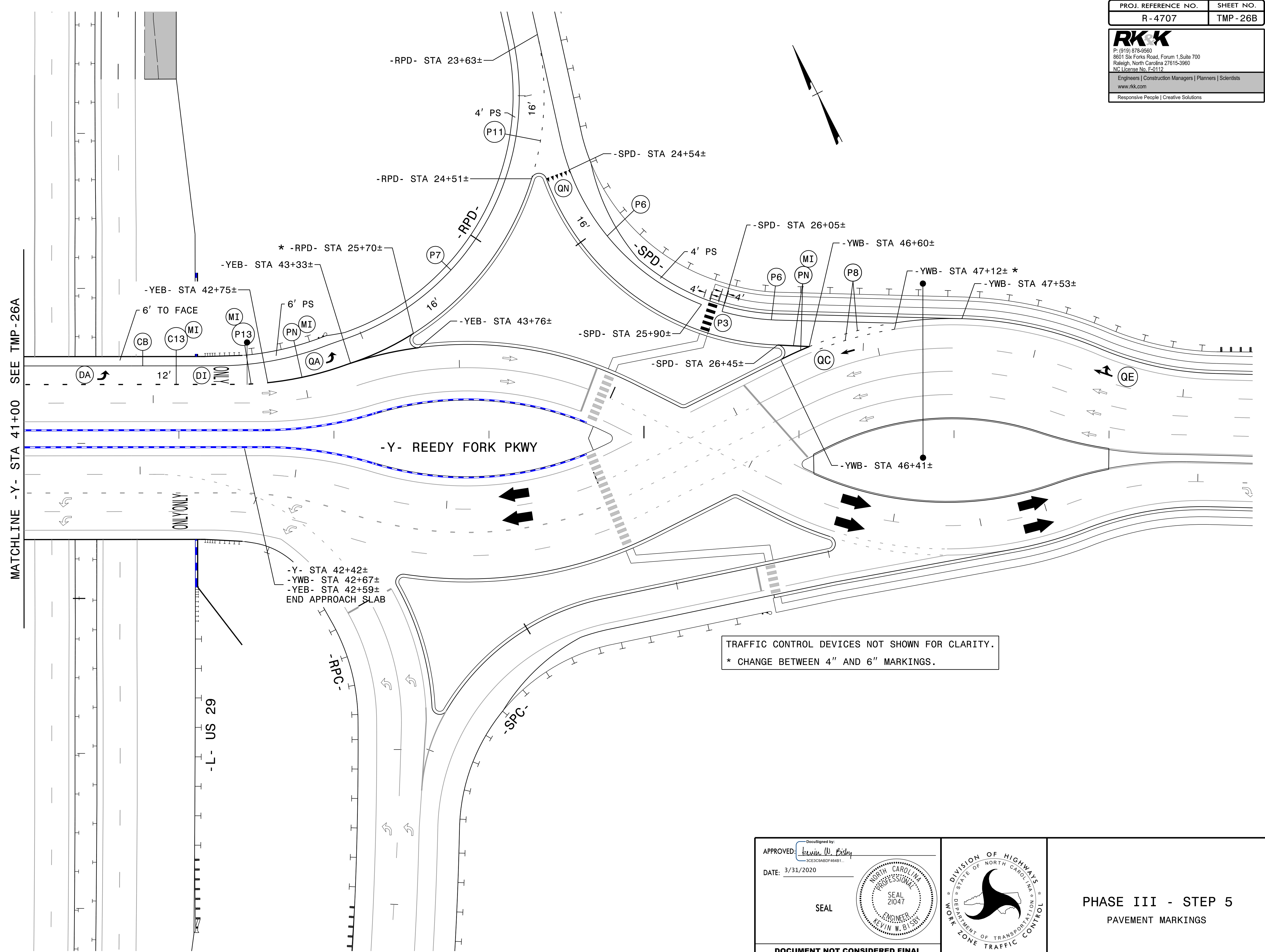

MATCHLINE -Y- STA 41+00 SEE TMP-26A

ONLY

-L- US 29

-Y- STA 42+42±
 -YWB- STA 42+67±
 -YEB- STA 42+59±
 END APPROACH SLAB

TRAFFIC CONTROL DEVICES NOT SHOWN FOR CLARITY.
 * CHANGE BETWEEN 4" AND 6" MARKINGS.

APPROVED: *Kevin W. Bisby*
 DATE: 3/31/2020

SEAL

SEAL 21047
 ENGINEER
 KEVIN W. BISBY

DOCUMENT NOT CONSIDERED FINAL
 UNLESS ALL SIGNATURES COMPLETED

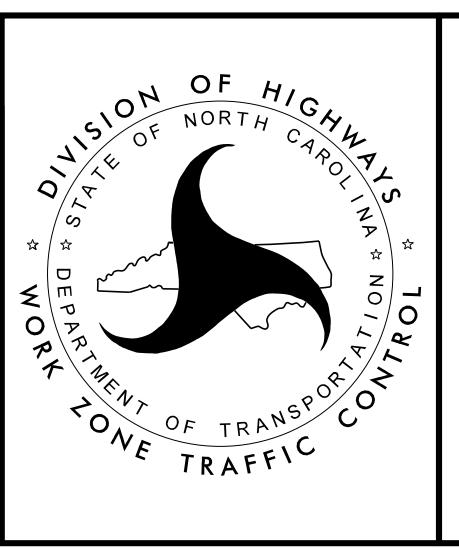

DIVISION OF HIGHWAYS
 STATE OF NORTH CAROLINA
 DEPARTMENT OF TRANSPORTATION
 WORK ZONE TRAFFIC CONTROL

PHASE III - STEP 5
 PAVEMENT MARKINGS

PROJ. REFERENCE NO. R - 4707	SHEET NO. TMP - 26C
---------------------------------	------------------------

RKK
 P: (919) 878-8560
 8601 Six Forks Road, Forum 1, Suite 700
 Raleigh, North Carolina 27615-3960
 NC License No. F-0112
 Engineers | Construction Managers | Planners | Scientists
 www.rkk.com
 Responsive People | Creative Solutions

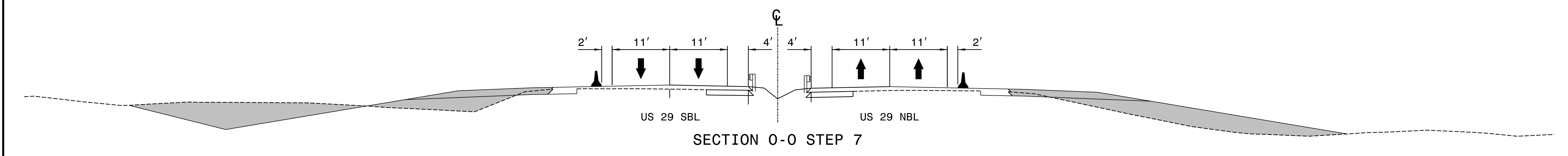
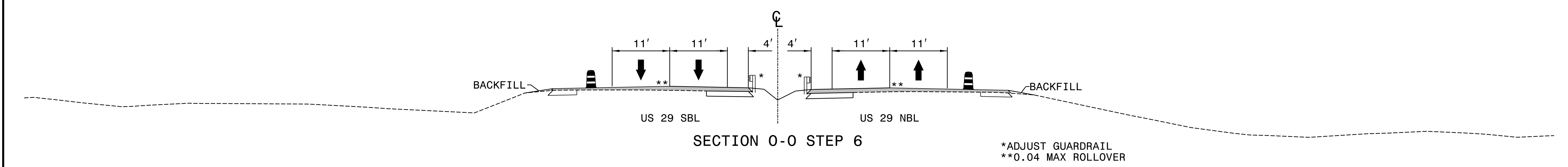

APPROVED: *Kevin W. Bisby*
 DATE: 3/31/2020

SEAL

SEAL 21047
 ENGINEER
 KEVIN W. BISBY

DOCUMENT NOT CONSIDERED FINAL
 UNLESS ALL SIGNATURES COMPLETED

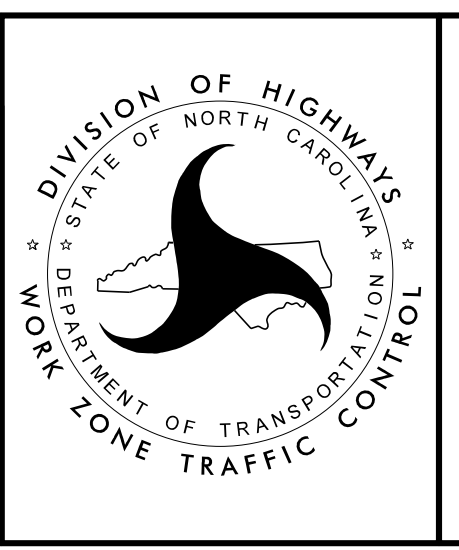

PHASE III
 STEPS 6 AND 7
 SECTION VIEWS

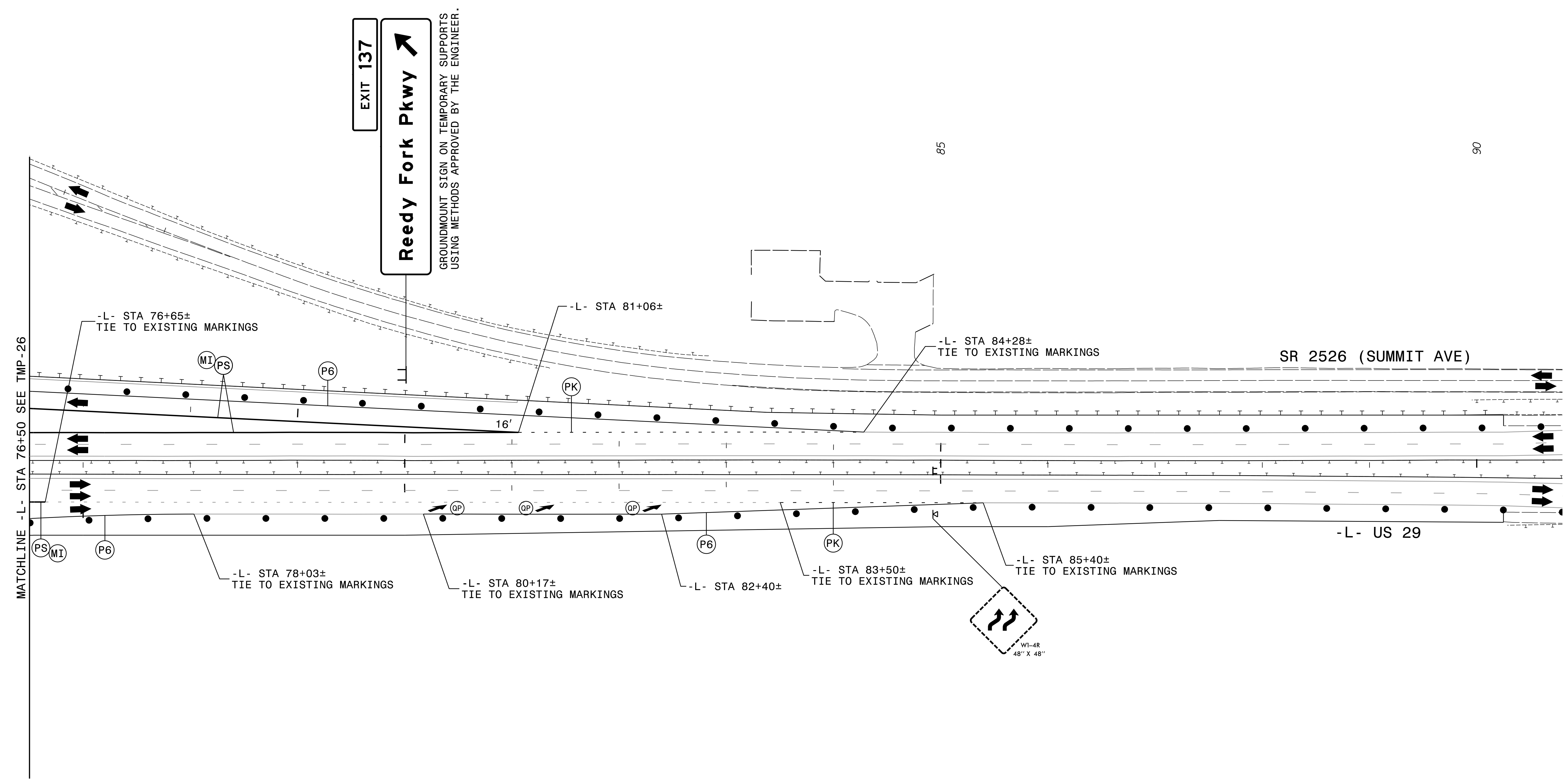
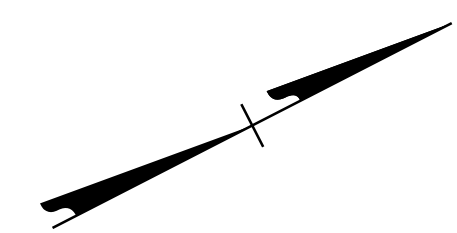

APPROVED: *Kevin W. Bisby*
 DATE: 3/31/2020
 SEAL
 NORTH CAROLINA
 PROFESSIONAL
 SEAL
 21047
 ENGINEER
 KEVIN W. BISBY

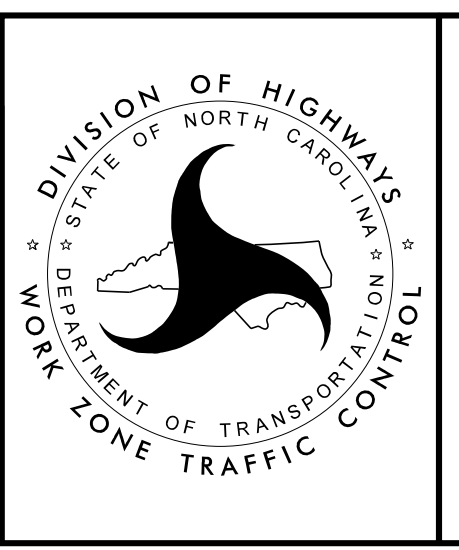

PHASE III - STEP 6

DOCUMENT NOT CONSIDERED FINAL
 UNLESS ALL SIGNATURES COMPLETED

RKK
 P: (919) 878-8560
 8601 Six Forks Road, Forum 1, Suite 700
 Raleigh, North Carolina 27615-3960
 NC License No. F-0112
 Engineers | Construction Managers | Planners | Scientists
 www.rkk.com
 Responsive People | Creative Solutions

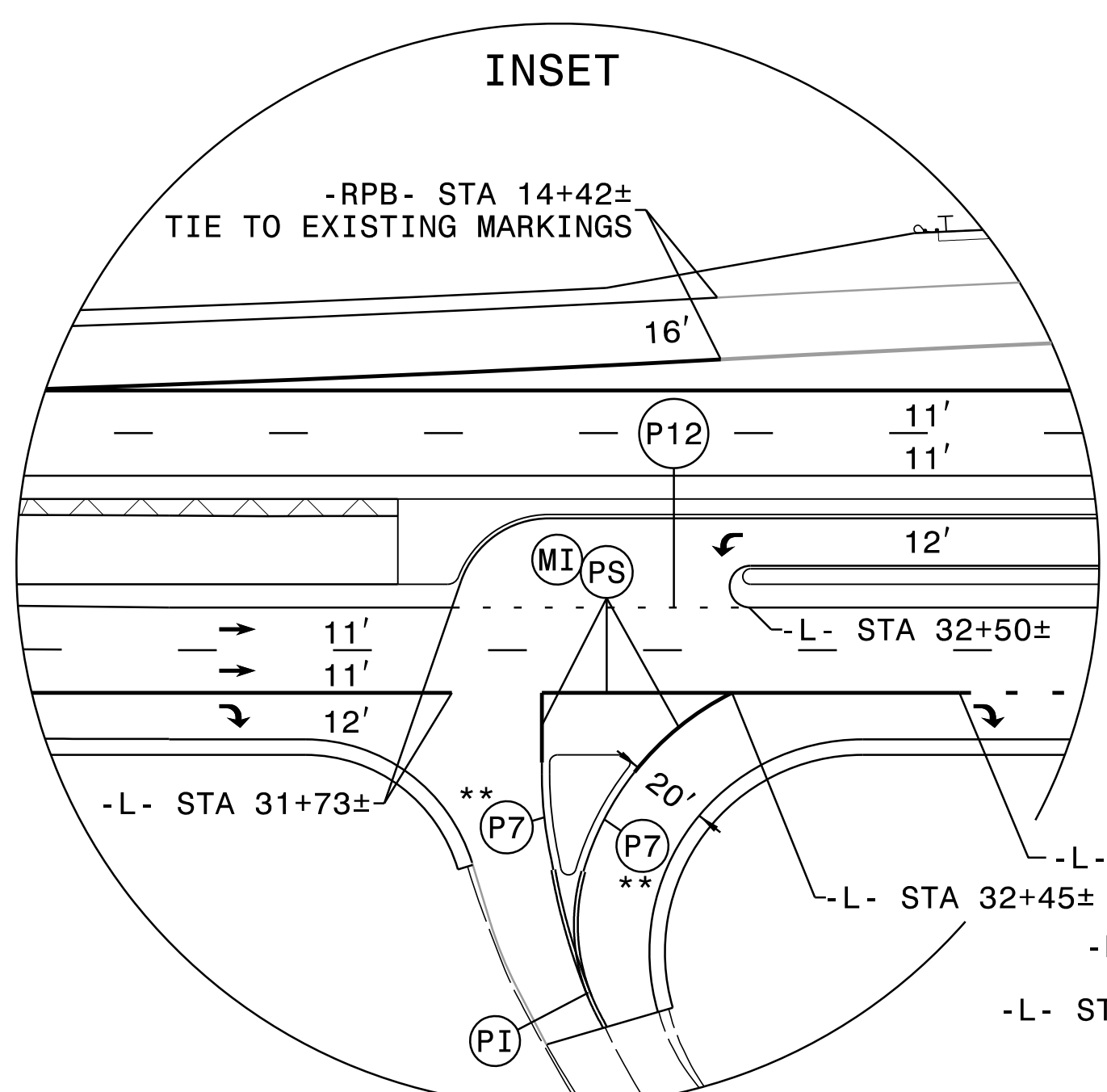
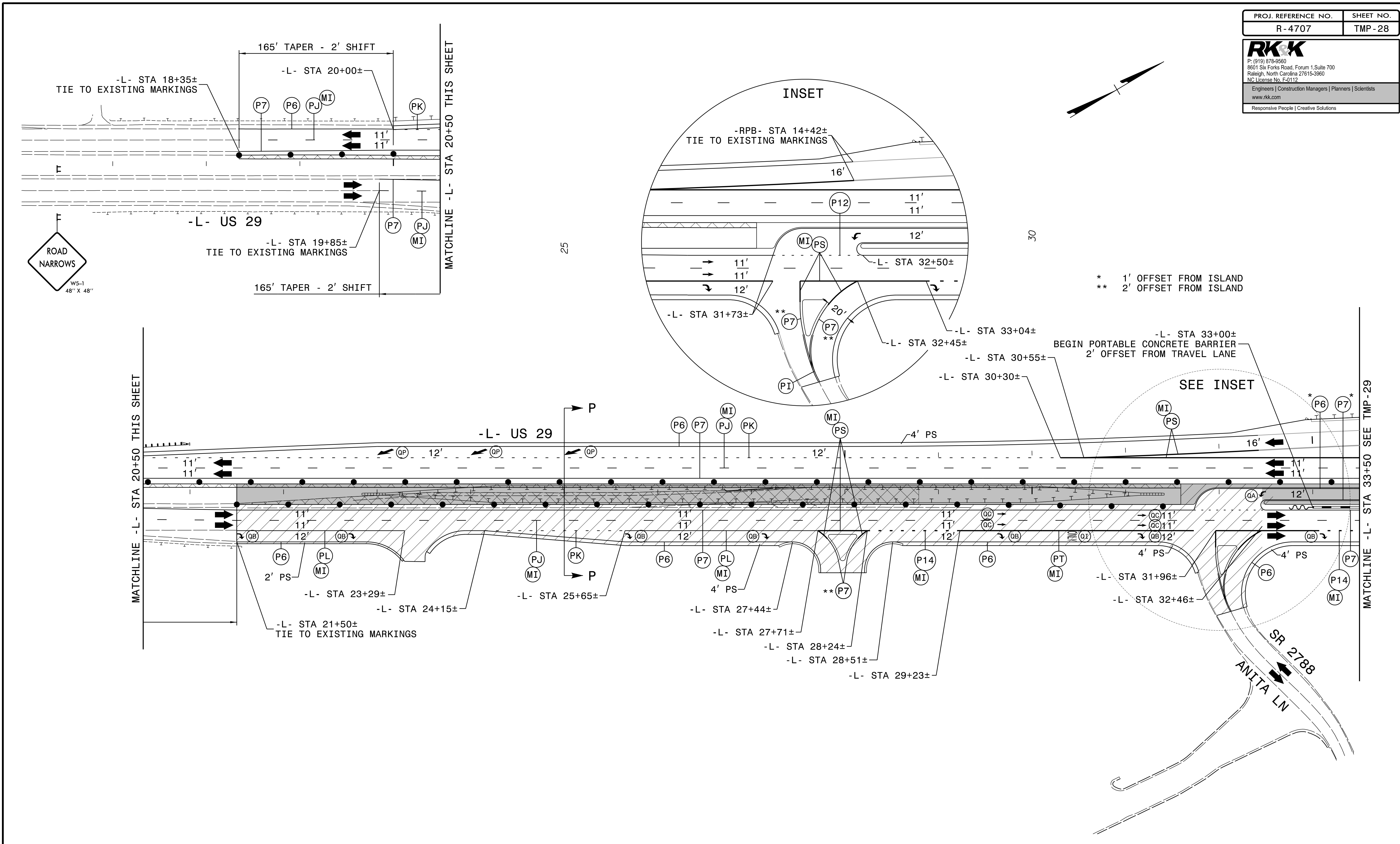
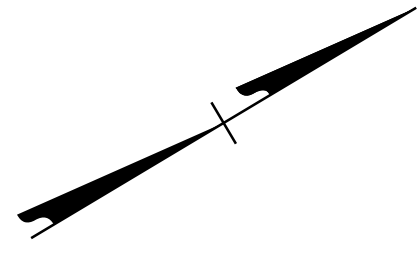

* 1' OFFSET FROM ISLAND
 ** 2' OFFSET FROM ISLAND

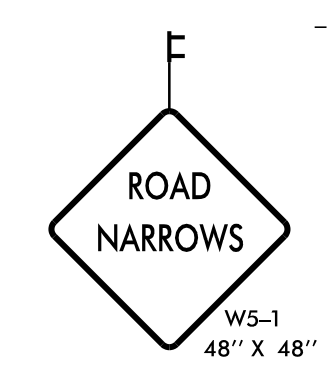

WEDGING

ERECT SIGNING PER SIGNING PLAN AS DIRECTED BY THE ENGINEER.
 SEE TMP-28A FOR SECTION VIEW.

APPROVED:
 DATE: 3/31/2020
 SEAL

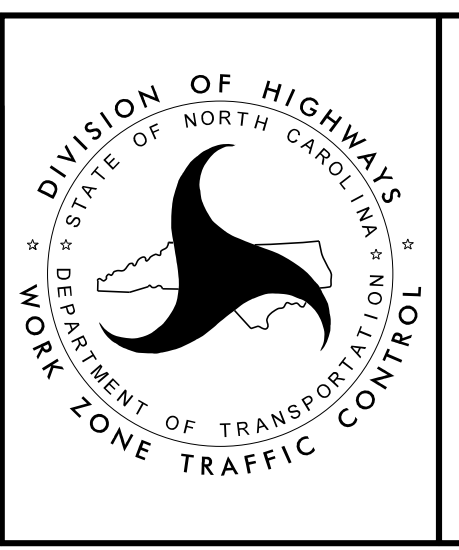

PHASE IV
 STEPS 1 THROUGH 3

PROJ. REFERENCE NO.	SHEET NO.
R - 4707	TMP - 28A

RKK
 P: (919) 878-8560
 8601 Six Forks Road, Forum 1, Suite 700
 Raleigh, North Carolina 27615-3960
 NC License No. F-0112
 Engineers | Construction Managers | Planners | Scientists
 www.rkk.com
 Responsive People | Creative Solutions

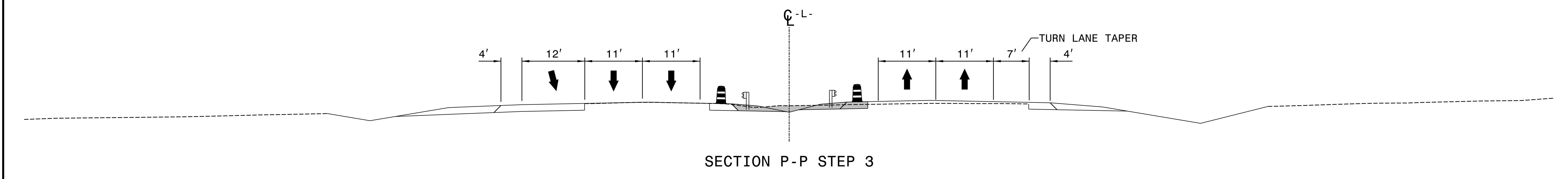
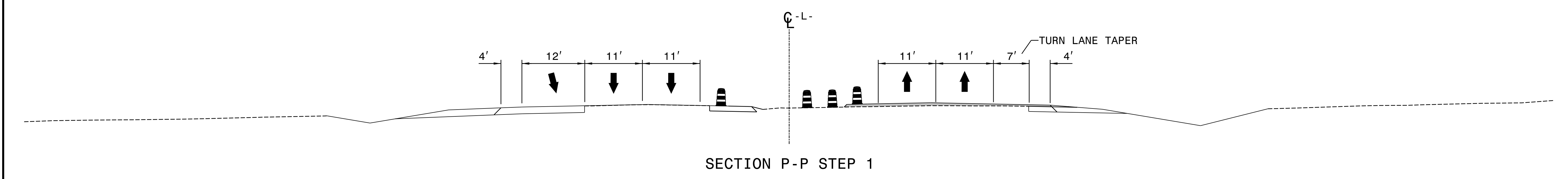

APPROVED: *Kevin W. Bisby*
 DATE: 3/31/2020

SEAL

PROFESSIONAL ENGINEER
 KEVIN W. BISBY
 SEAL 21047
 NORTH CAROLINA

**DOCUMENT NOT CONSIDERED FINAL
 UNLESS ALL SIGNATURES COMPLETED**

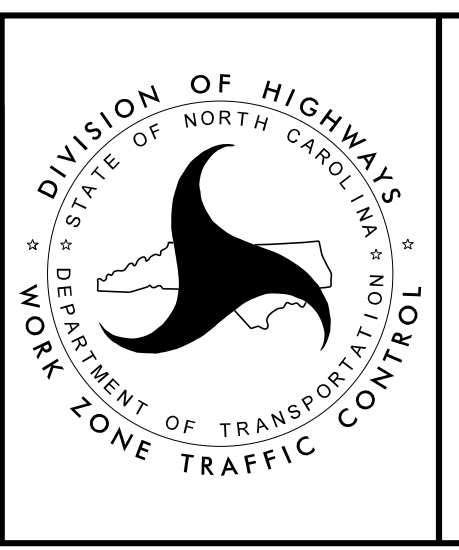

PHASE IV
 STEPS 1 AND 3
 SECTION VIEWS

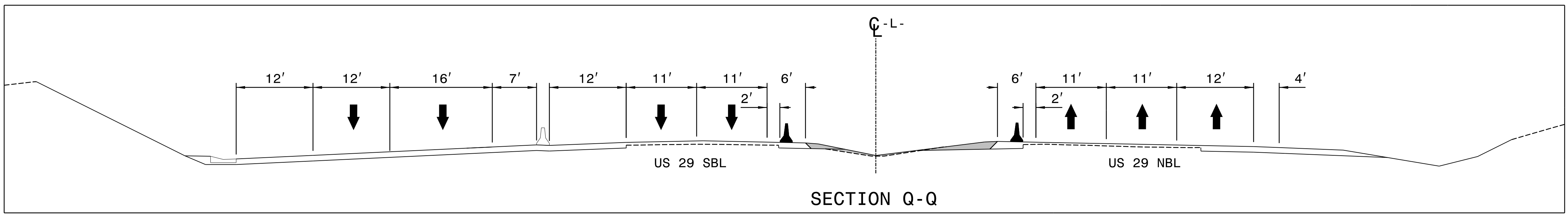
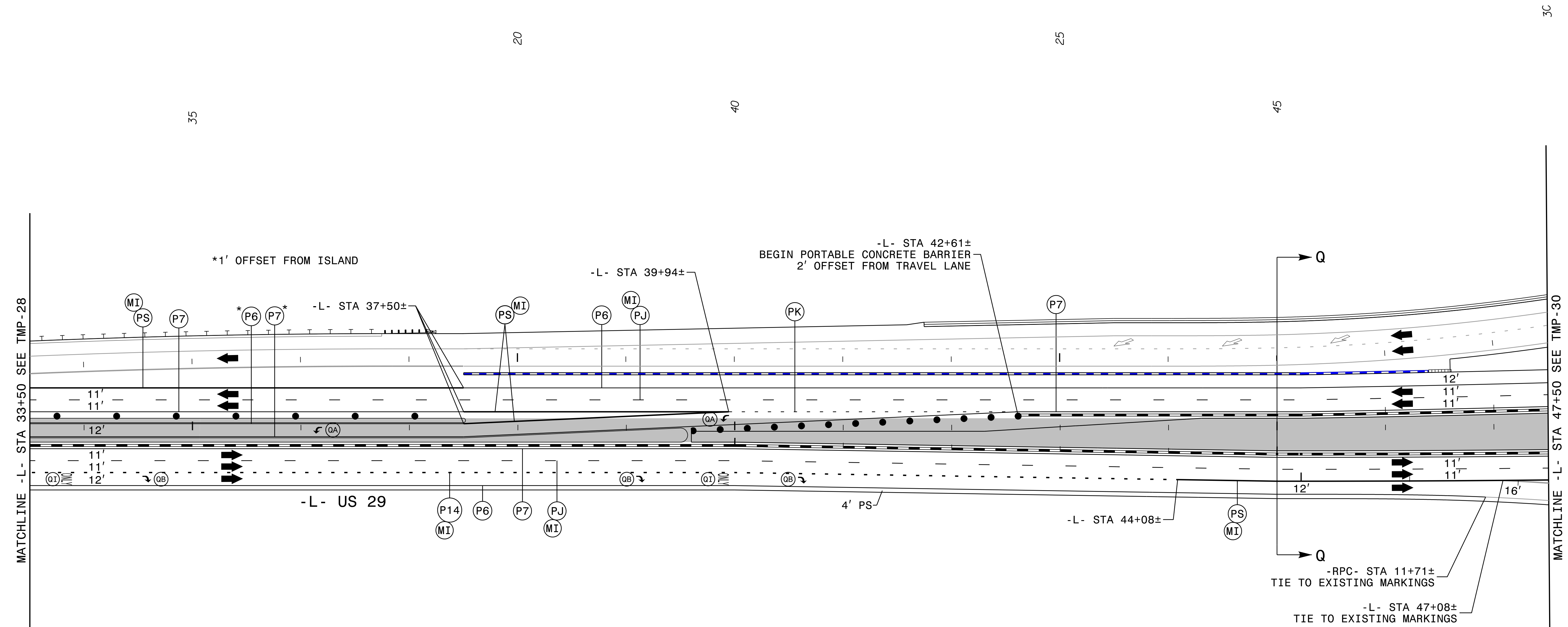
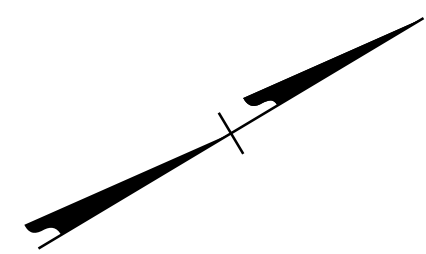

ERECT SIGNING PER SIGNING PLAN AS DIRECTED BY THE ENGINEER.

APPROVED: *Kevin W. Bisby*
 DATE: 3/31/2020
 SEAL
 NORTH CAROLINA PROFESSIONAL ENGINEER
 SEAL 21047
 KEVIN W. BISBY

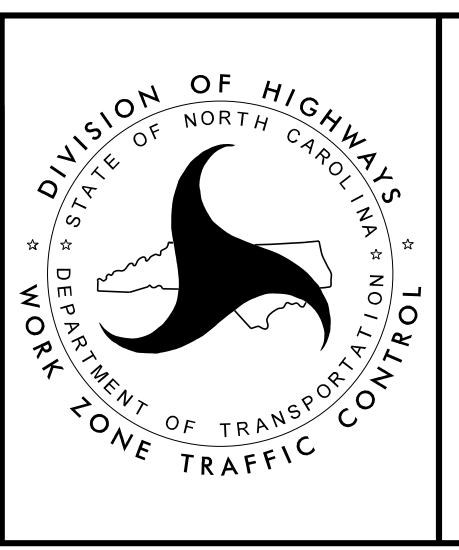

PHASE IV
 STEPS 1 THROUGH 3

DOCUMENT NOT CONSIDERED FINAL
 UNLESS ALL SIGNATURES COMPLETED

RKK
 P: (919) 578-8560
 8601 Six Forks Road, Forum 1, Suite 700
 Raleigh, North Carolina 27615-3960
 NC License No. F-0112
 Engineers | Construction Managers | Planners | Scientists
 www.rkk.com
 Responsive People | Creative Solutions

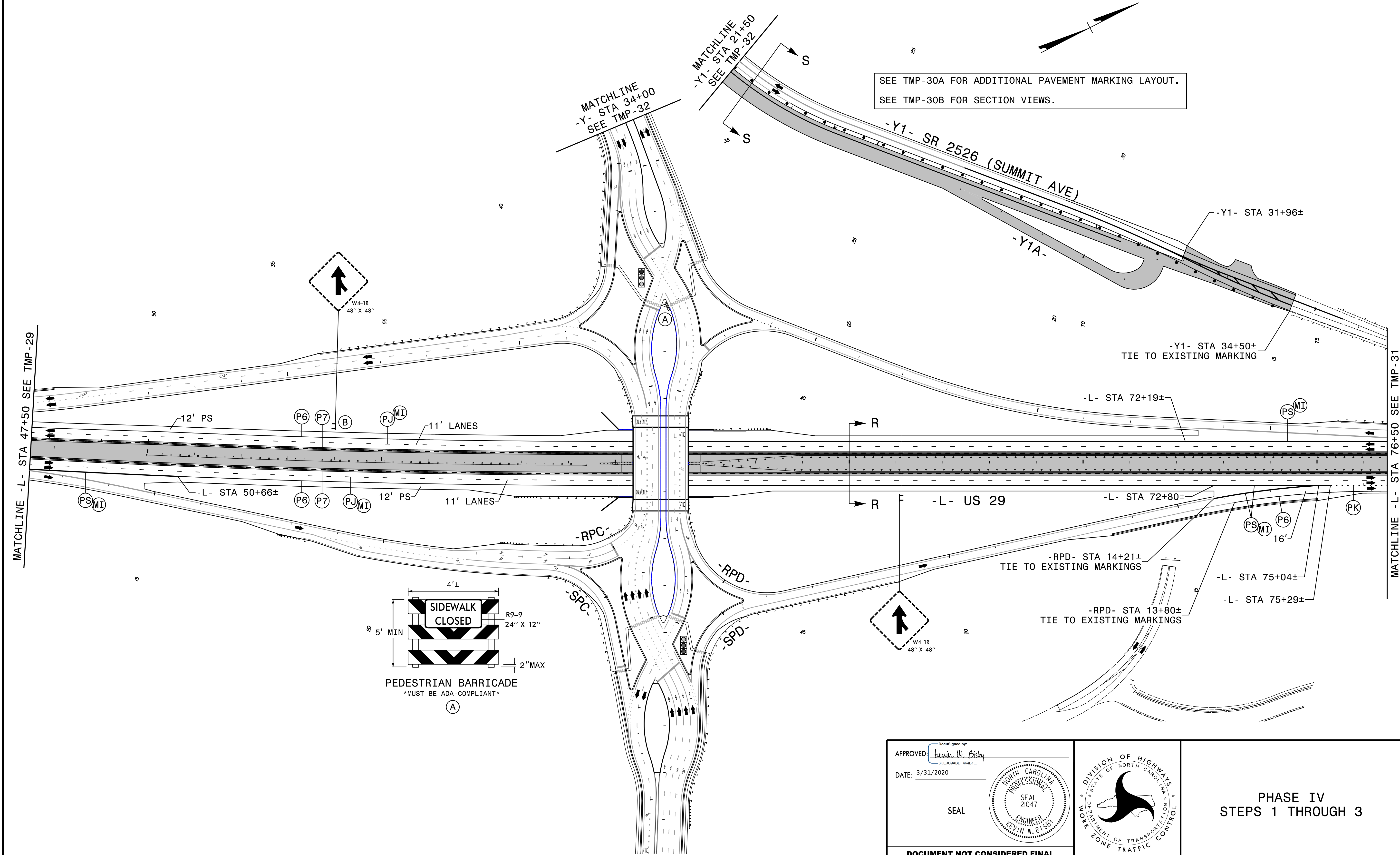

SEE TMP-30A FOR ADDITIONAL PAVEMENT MARKING LAYOUT.
 SEE TMP-30B FOR SECTION VIEWS.

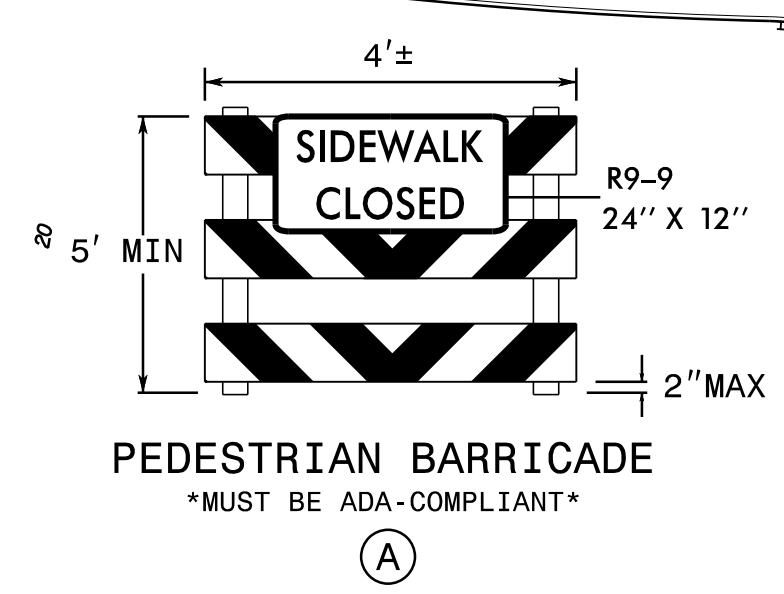

APPROVED: *Kevin W. Bisby*
 DATE: 3/31/2020
 SEAL
 NORTH CAROLINA PROFESSIONAL ENGINEER
 SEAL 21047
 KEVIN W. BISBY

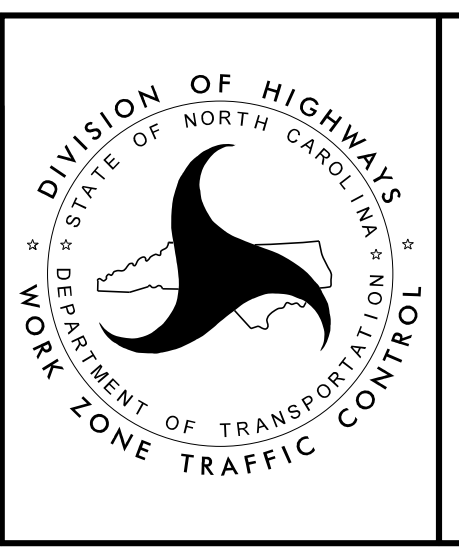

PHASE IV
 STEPS 1 THROUGH 3

3/31/2020
 R:\DOT\TMP_PSH30.dgn
 gbfault

DOCUMENT NOT CONSIDERED FINAL
 UNLESS ALL SIGNATURES COMPLETED

PROJ. REFERENCE NO.	SHEET NO.
R-4707	TMP-30A

RKK
 P: (919) 878-8560
 8601 Six Forks Road, Forum 1, Suite 700
 Raleigh, North Carolina 27615-3960
 NC License No. F-0112
 Engineers | Construction Managers | Planners | Scientists
 www.rkk.com
 Responsive People | Creative Solutions

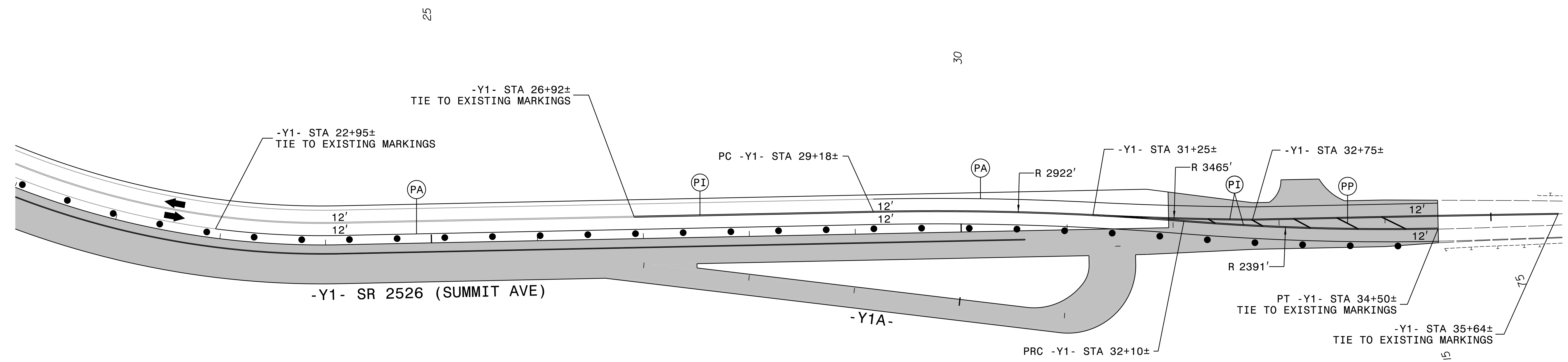
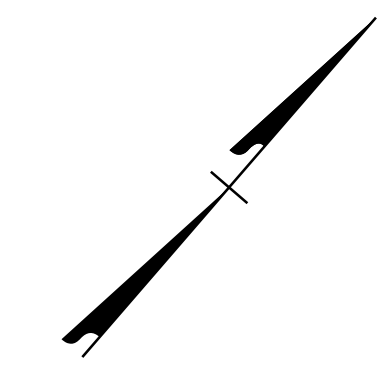

APPROVED: *Kevin W. Bisby*
 DATE: 3/31/2020

SEAL

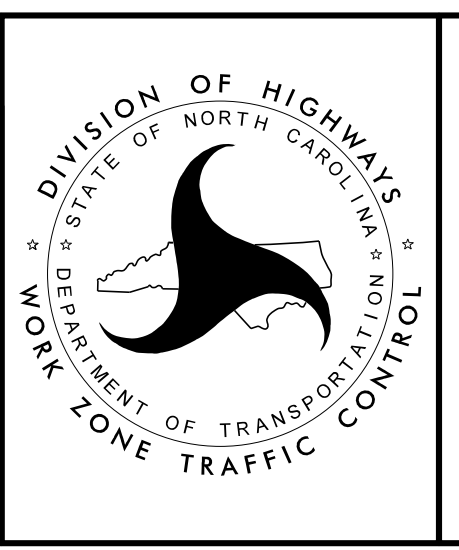

PHASE IV - STEP 3
 PAVEMENT MARKINGS

**DOCUMENT NOT CONSIDERED FINAL
 UNLESS ALL SIGNATURES COMPLETED**

PROJ. REFERENCE NO.	SHEET NO.
R - 4707	TMP - 30B

RKK
 P: (919) 878-8560
 8601 Six Forks Road, Forum 1, Suite 700
 Raleigh, North Carolina 27615-3960
 NC License No. F-0112
 Engineers | Construction Managers | Planners | Scientists
 www.rkk.com
 Responsive People | Creative Solutions

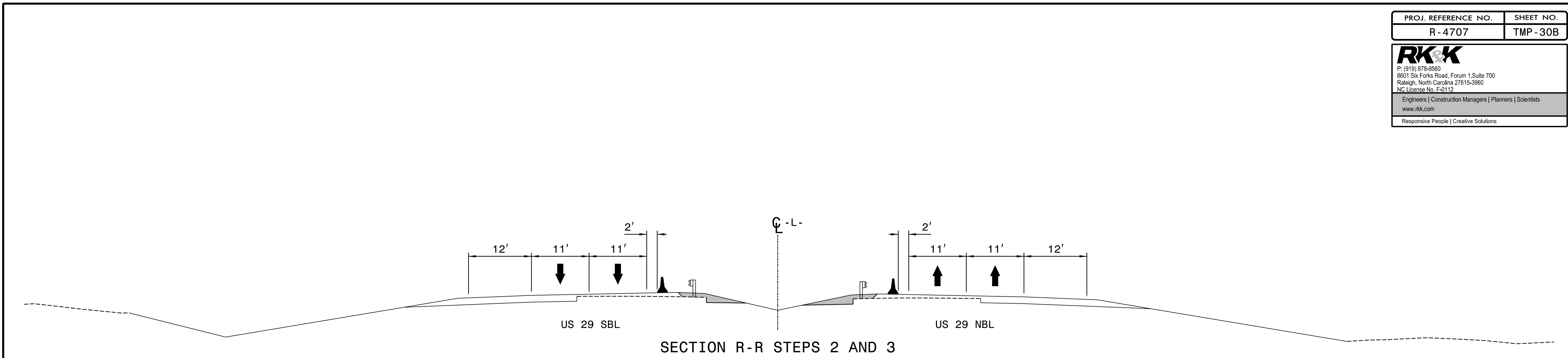

SECTION R-R STEPS 2 AND 3

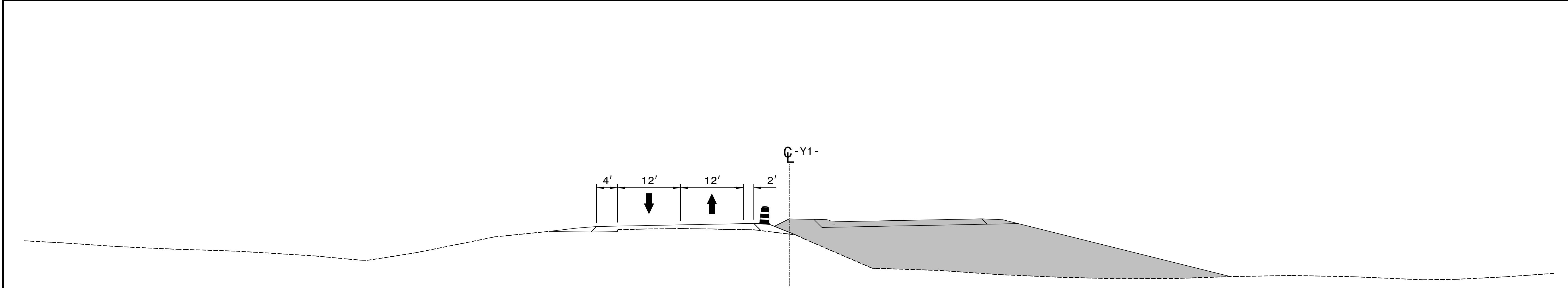

SECTION S-S STEP 3

APPROVED: *Kevin W. Bisby*
 DATE: 3/31/2020

SEAL

PROFESSIONAL ENGINEER
 KEVIN W. BISBY
 SEAL 21047

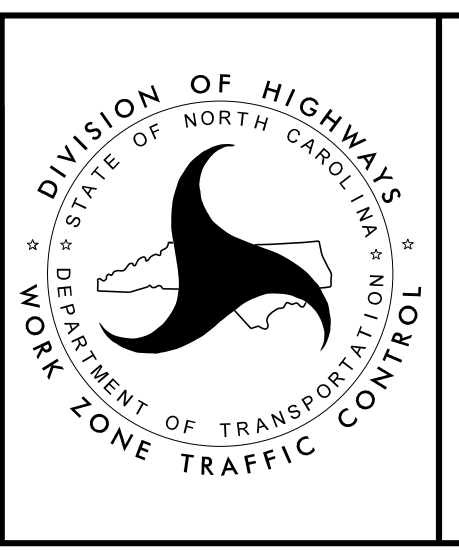

PHASE IV - STEP 3
 SECTION VIEWS

DOCUMENT NOT CONSIDERED FINAL
 UNLESS ALL SIGNATURES COMPLETED

RKK
 P: (919) 878-8560
 8601 Six Forks Road, Forum 1, Suite 700
 Raleigh, North Carolina 27615-3960
 NC License No. F-0112
 Engineers | Construction Managers | Planners | Scientists
 www.rkk.com
 Responsive People | Creative Solutions

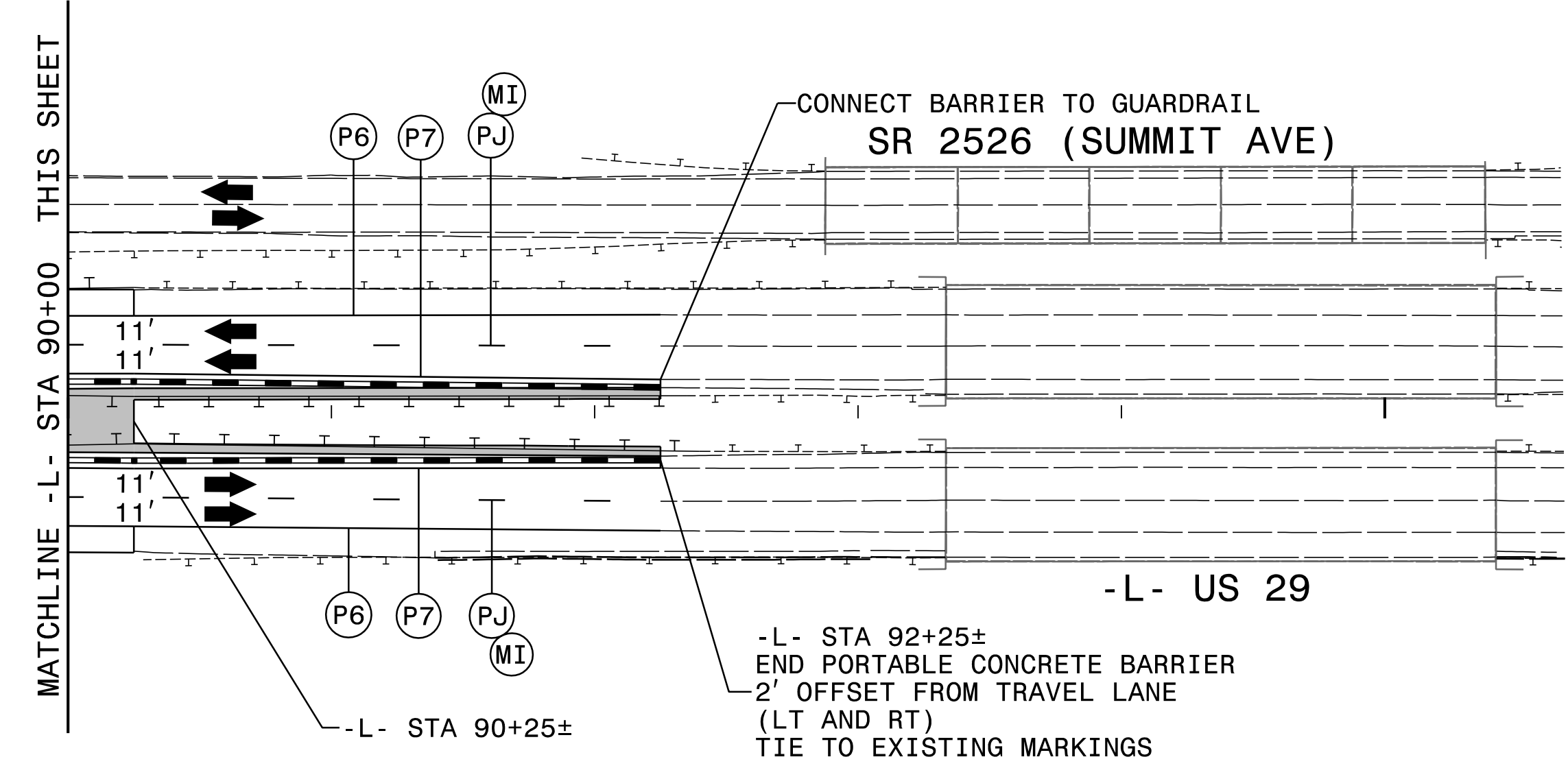
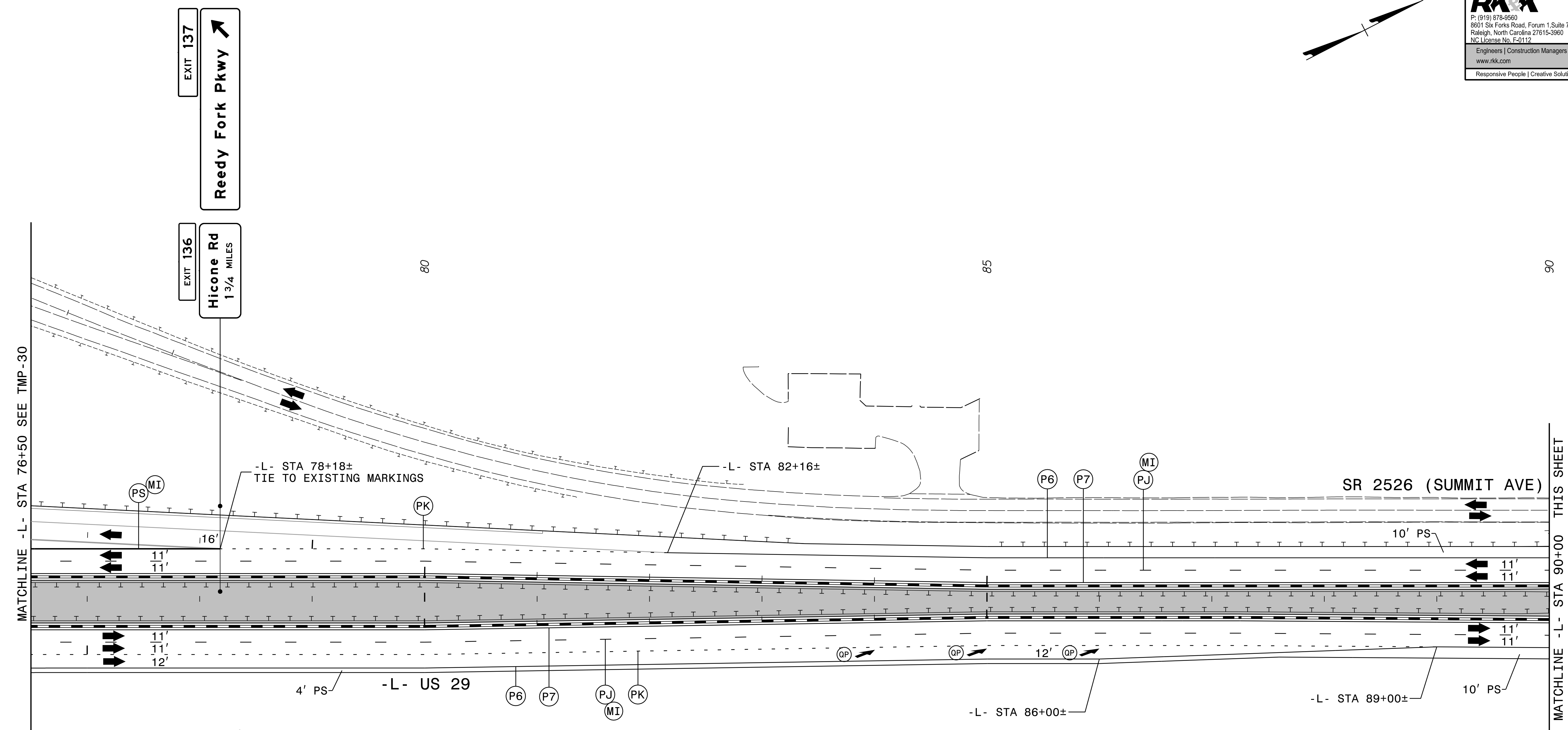
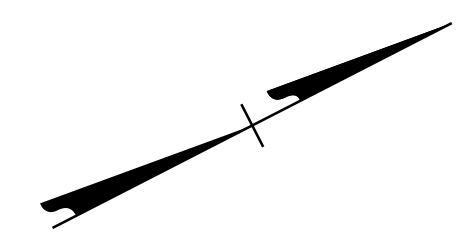

APPROVED: *Kevin W. Bisby*
 DATE: 3/31/2020

SEAL

SEAL 21047
 ENGINEER
 KEVIN W. BISBY

DOCUMENT NOT CONSIDERED FINAL
 UNLESS ALL SIGNATURES COMPLETED

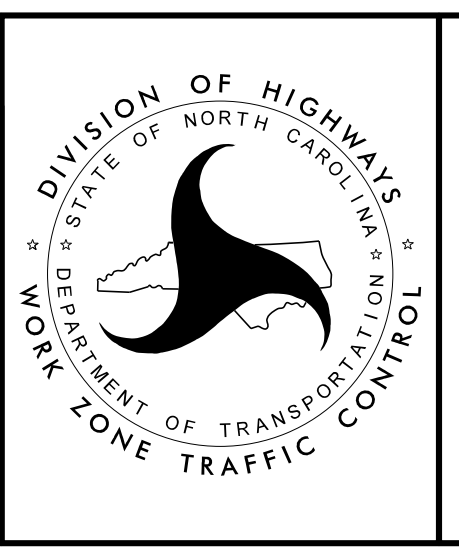

PHASE IV
 STEPS 1 THROUGH 3

RKK
 P: (919) 878-8560
 8601 Six Forks Road, Forum 1, Suite 700
 Raleigh, North Carolina 27615-3960
 NC License No. F-0112
 Engineers | Construction Managers | Planners | Scientists
 www.rkk.com
 Responsive People | Creative Solutions

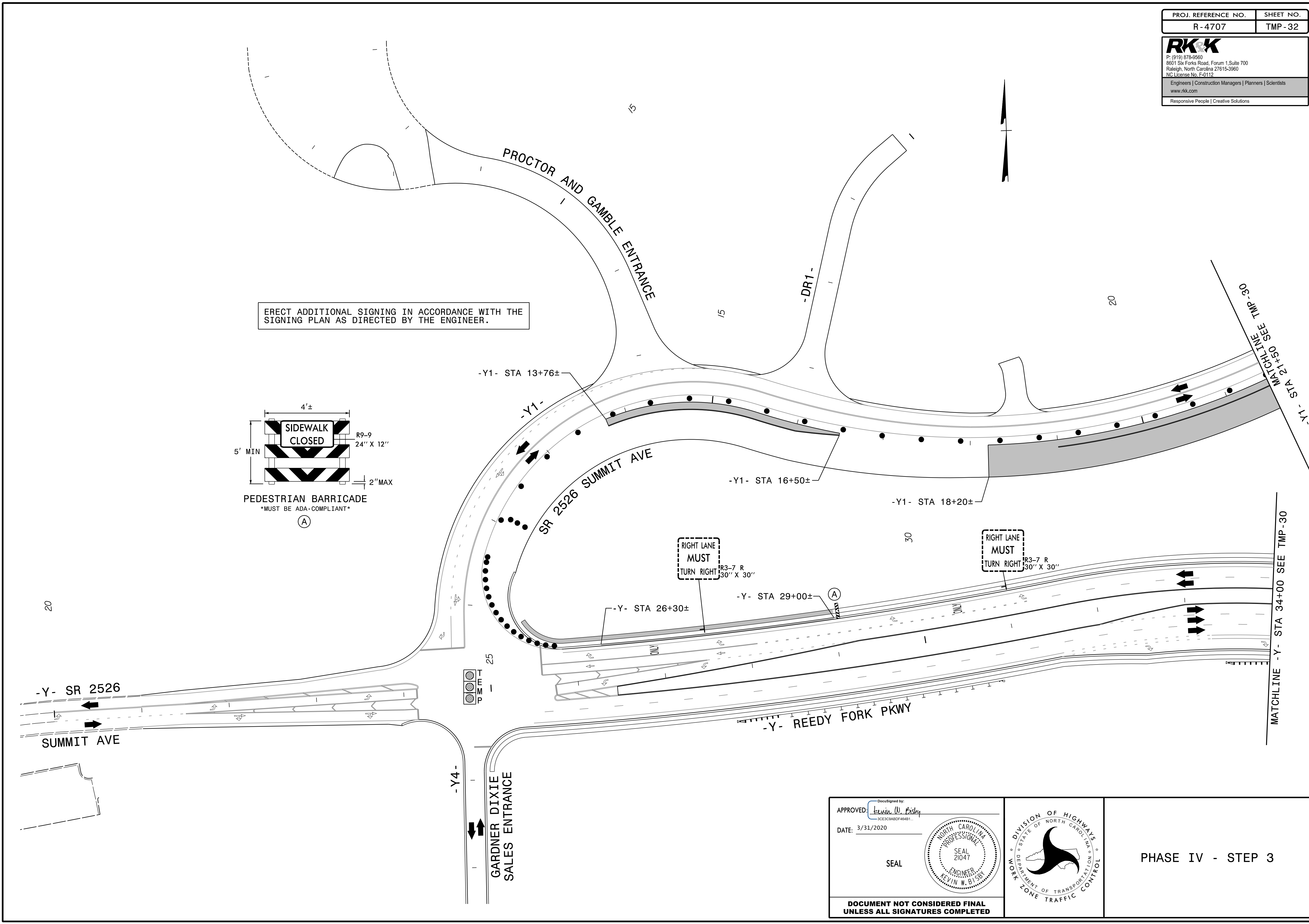

ERECT ADDITIONAL SIGNING IN ACCORDANCE WITH THE SIGNING PLAN AS DIRECTED BY THE ENGINEER.

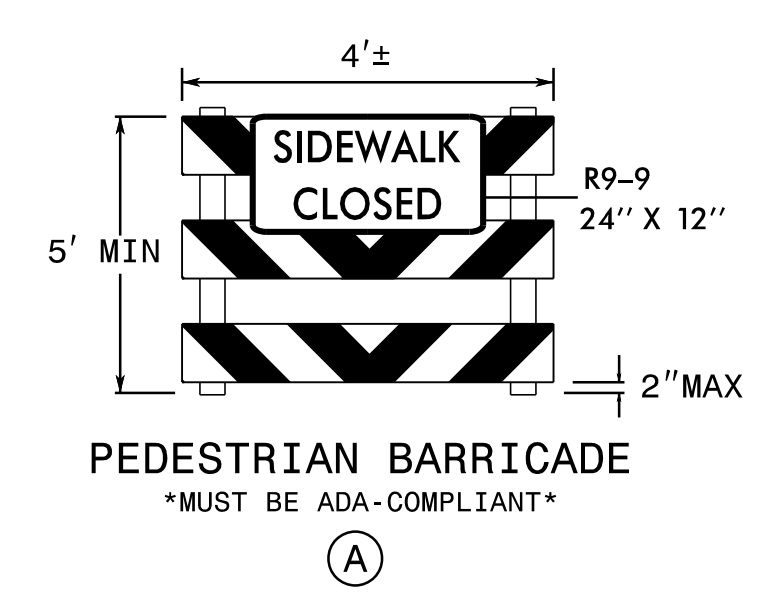

RIGHT LANE MUST TURN RIGHT
 R3-7 R
 30" X 30"

RIGHT LANE MUST TURN RIGHT
 R3-7 R
 30" X 30"

APPROVED: *Kevin W. Bisby*
 DATE: 3/31/2020

SEAL

SEAL
 21047
 ENGINEER
 KEVIN W. BISBY

DOCUMENT NOT CONSIDERED FINAL UNLESS ALL SIGNATURES COMPLETED

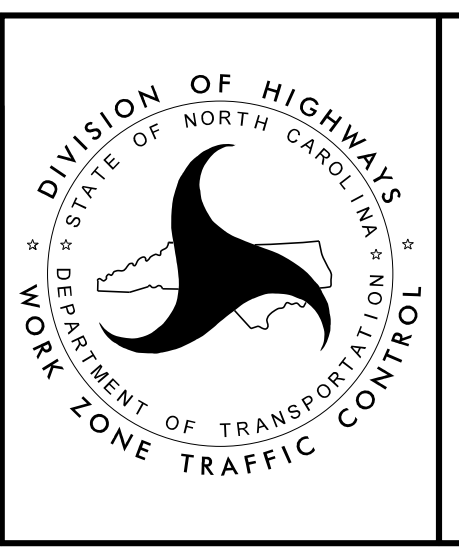

DIVISION OF HIGHWAYS
 STATE OF NORTH CAROLINA
 DEPARTMENT OF TRANSPORTATION
 WORK ZONE TRAFFIC CONTROL

PHASE IV - STEP 3

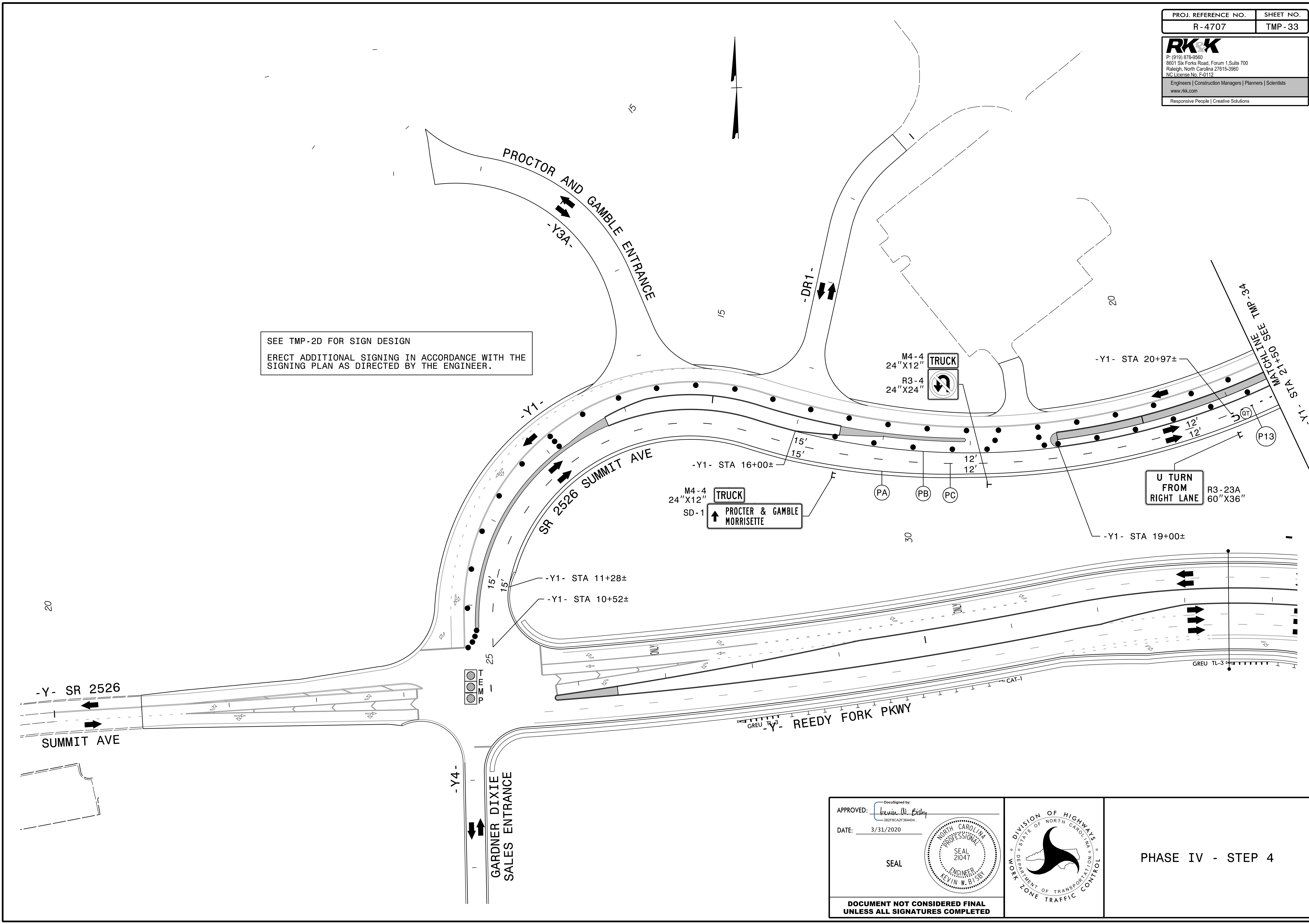

SEE TMP-2D FOR SIGN DESIGN
 ERECT ADDITIONAL SIGNING IN ACCORDANCE WITH THE
 SIGNING PLAN AS DIRECTED BY THE ENGINEER.

APPROVED: *Kevin W. Bisby*
 DATE: 3/31/2020
 SEAL

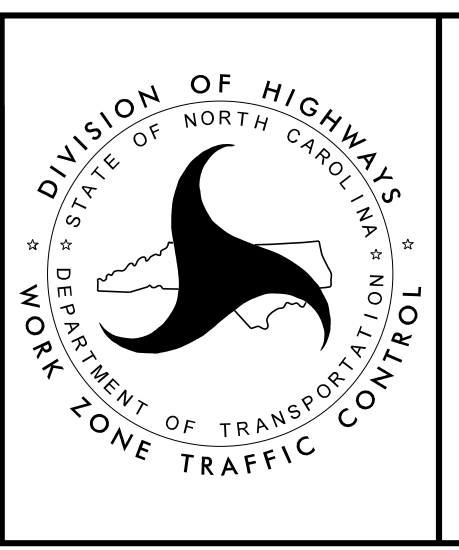

PHASE IV - STEP 4

DOCUMENT NOT CONSIDERED FINAL
 UNLESS ALL SIGNATURES COMPLETED

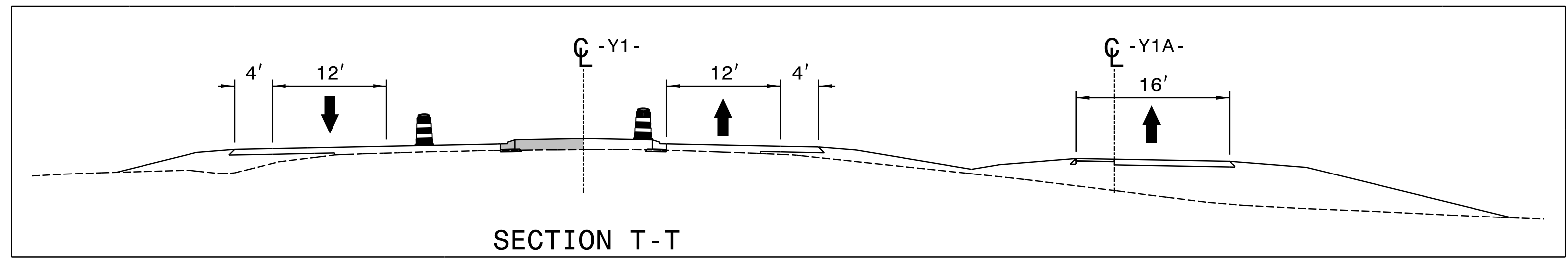
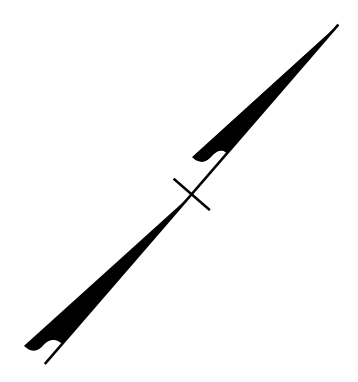

25

30

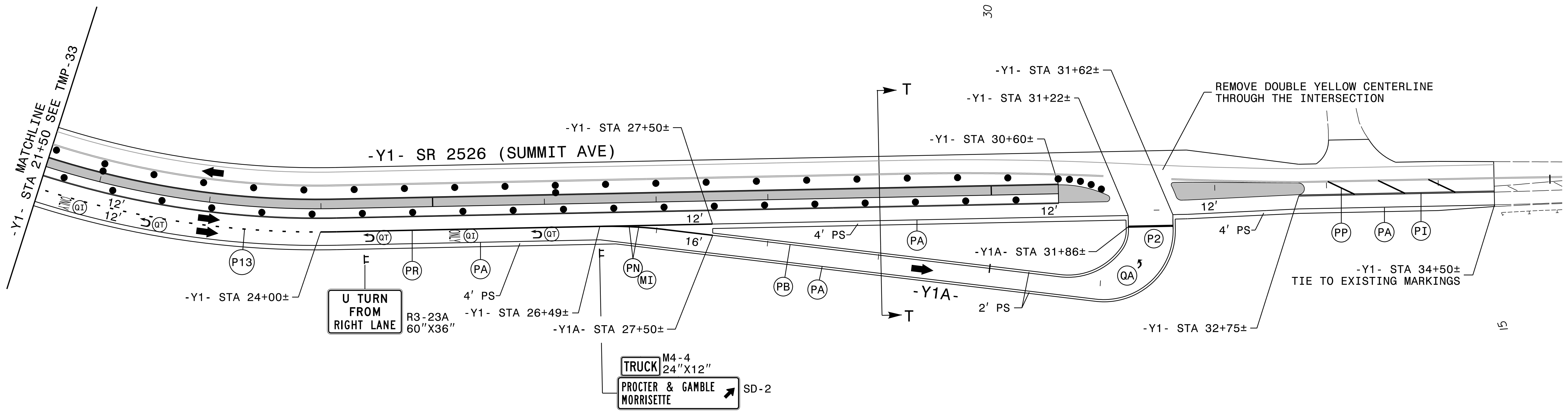

SEE TMP-2D FOR SIGN DESIGN
 ERECT ADDITIONAL SIGNING IN ACCORDANCE WITH THE
 SIGNING PLAN AS DIRECTED BY THE ENGINEER.

APPROVED: *Kevin W. Bisby*
 DATE: 3/31/2020

SEAL

DOCUMENT NOT CONSIDERED FINAL
 UNLESS ALL SIGNATURES COMPLETED

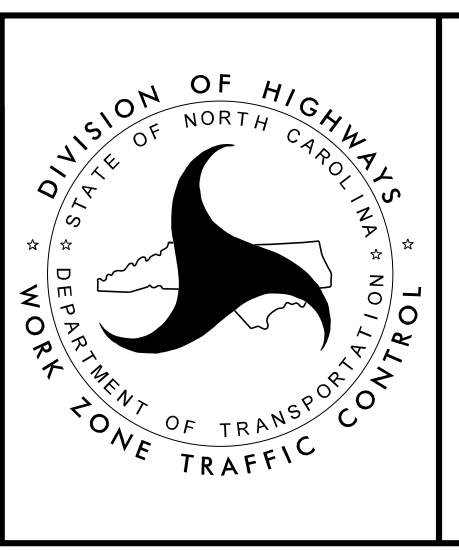

PHASE IV - STEP 4