

UTILITY CONSTRUCTION

DOCUMENT NOT CONSIDERED FINAL UNLESS ALL SIGNATURES COMPLETED

FINAL DESIGN RELEASE FOR CONSTRUCTION

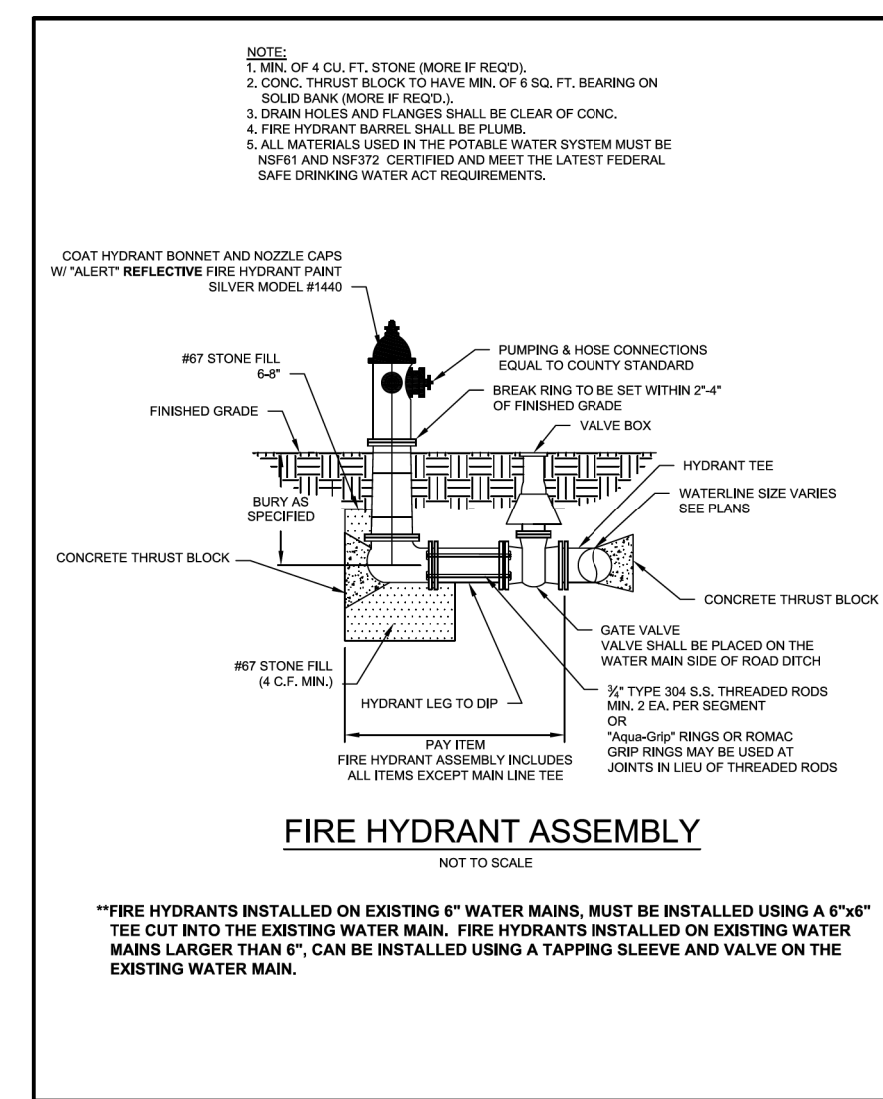

Drawn By:	Name:	Date:	JOHNSTON COUNTY Department of Public Utilities P.O. Box 2303 SHEPHERD, NC 27577	WATER STANDARD DETAIL Fire Hydrant Assembly	PAGE 4
-----------	-------	-------	--	--	--------

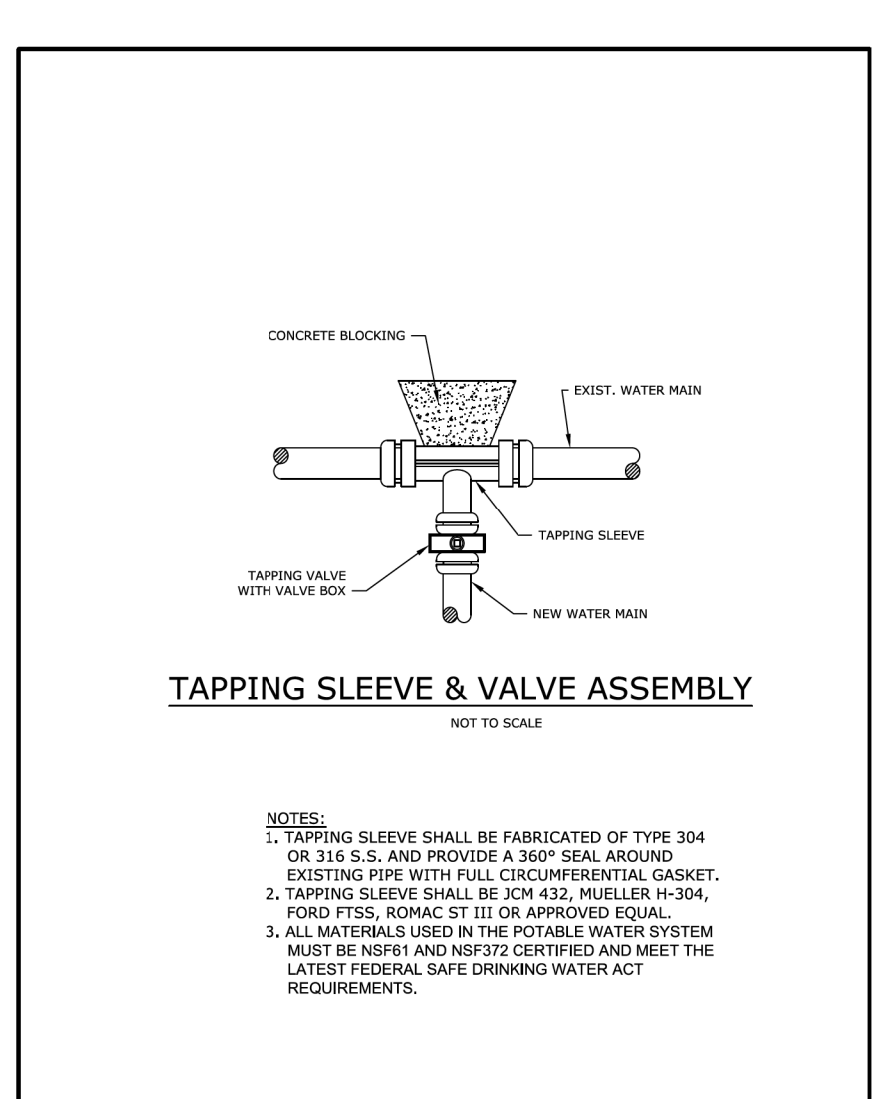

Drawn By:	Name:	Date:	JOHNSTON COUNTY Department of Public Utilities P.O. Box 2303 SHEPHERD, NC 27577	WATER STANDARD DETAIL Tapping Sleeve and Valve Assembly	PAGE 5
-----------	-------	-------	--	--	--------

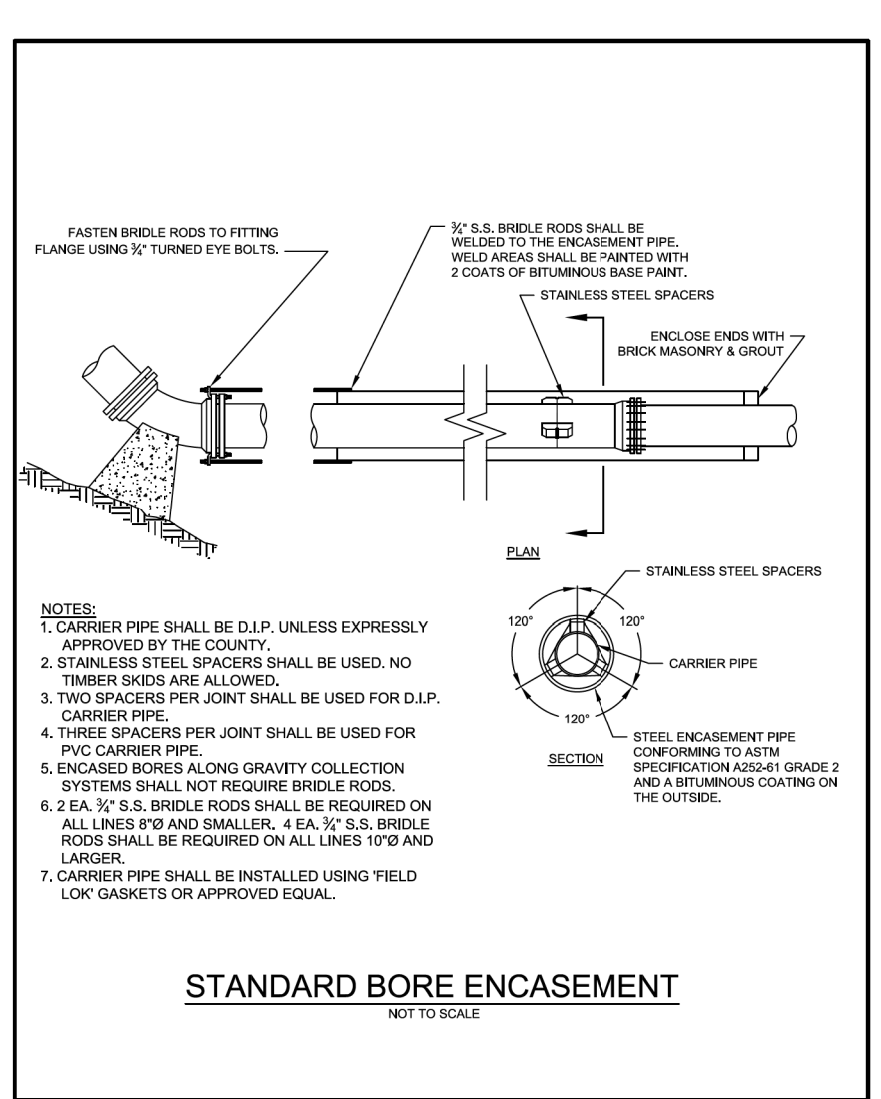

Drawn By:	Name:	Date:	JOHNSTON COUNTY Department of Public Utilities P.O. Box 2303 SHEPHERD, NC 27577	WATER STANDARD DETAIL Standard Bore Encasement	PAGE 6
-----------	-------	-------	--	---	--------

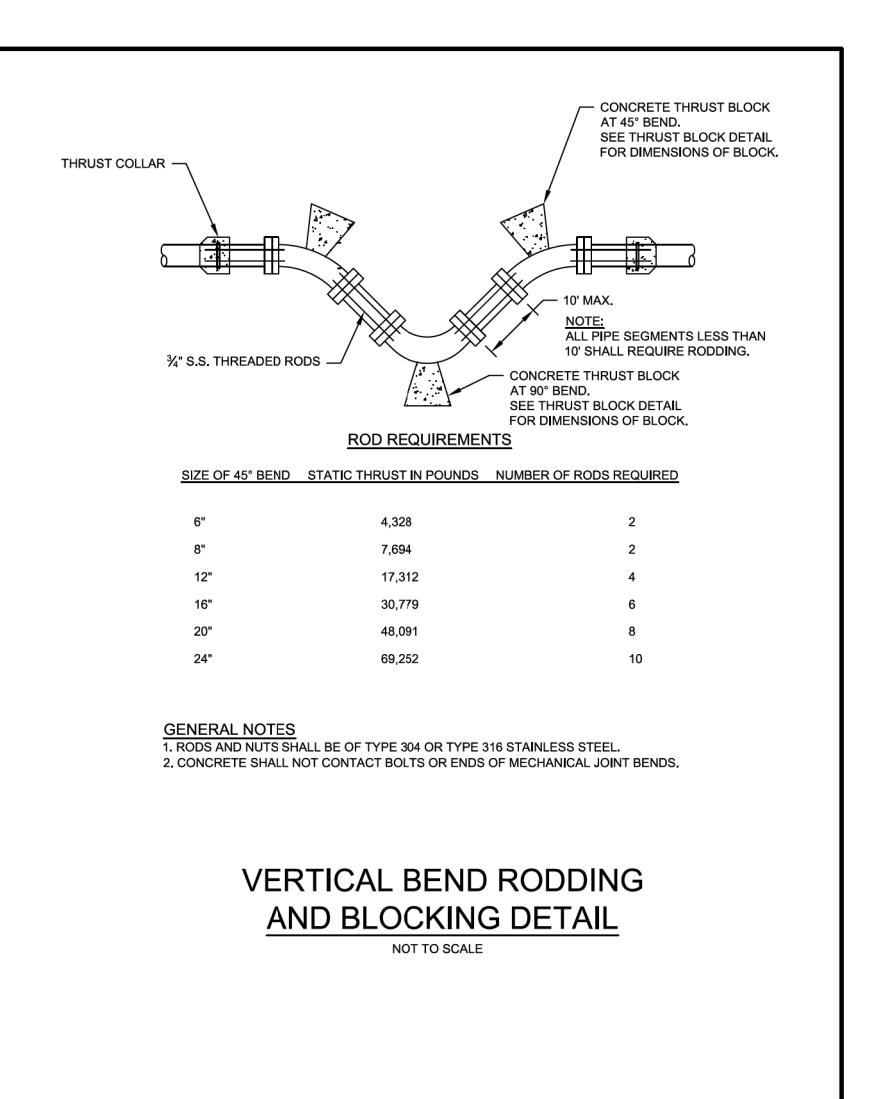

Drawn By:	Name:	Date:	JOHNSTON COUNTY Department of Public Utilities P.O. Box 2303 SHEPHERD, NC 27577	WATER STANDARD DETAIL Vertical Bend Rodding and Blocking Details	PAGE 7
-----------	-------	-------	--	---	--------

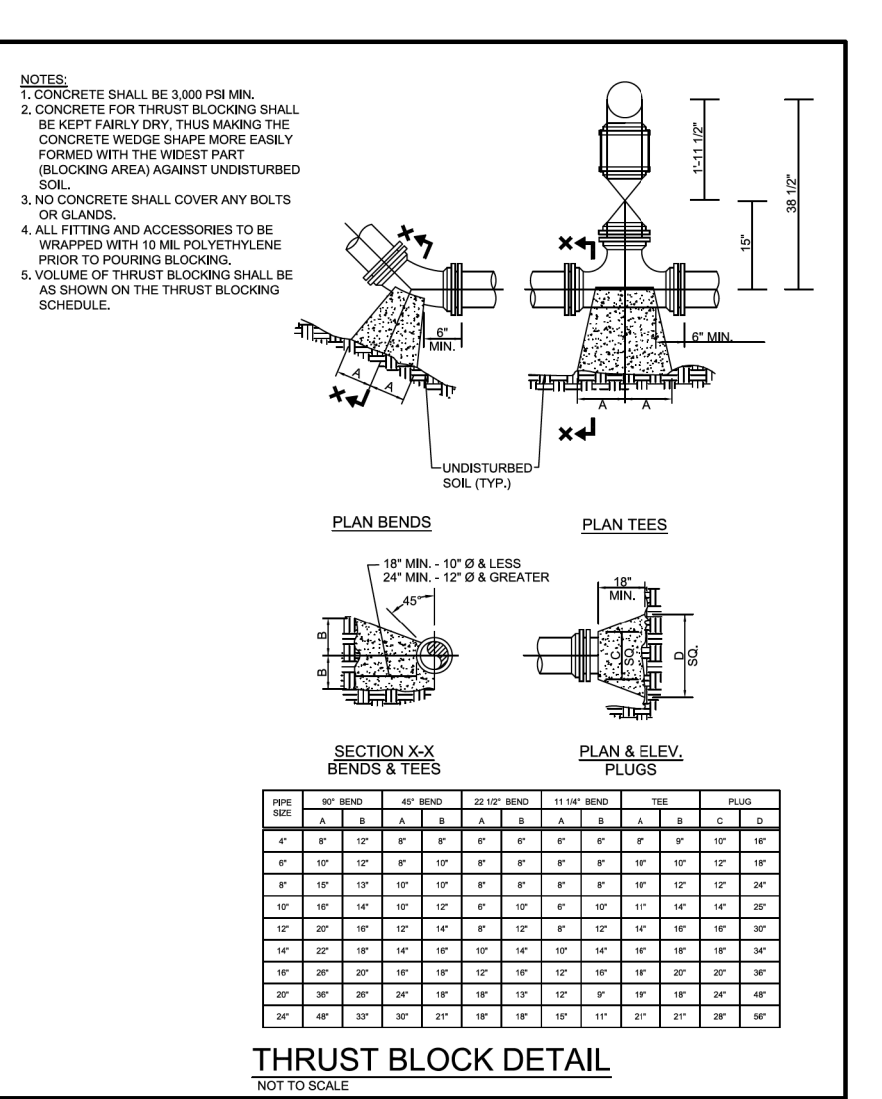

Drawn By:	Name:	Date:	JOHNSTON COUNTY Department of Public Utilities P.O. Box 2303 SHEPHERD, NC 27577	WATER STANDARD DETAIL Thrust Block	PAGE 8
-----------	-------	-------	--	---------------------------------------	--------

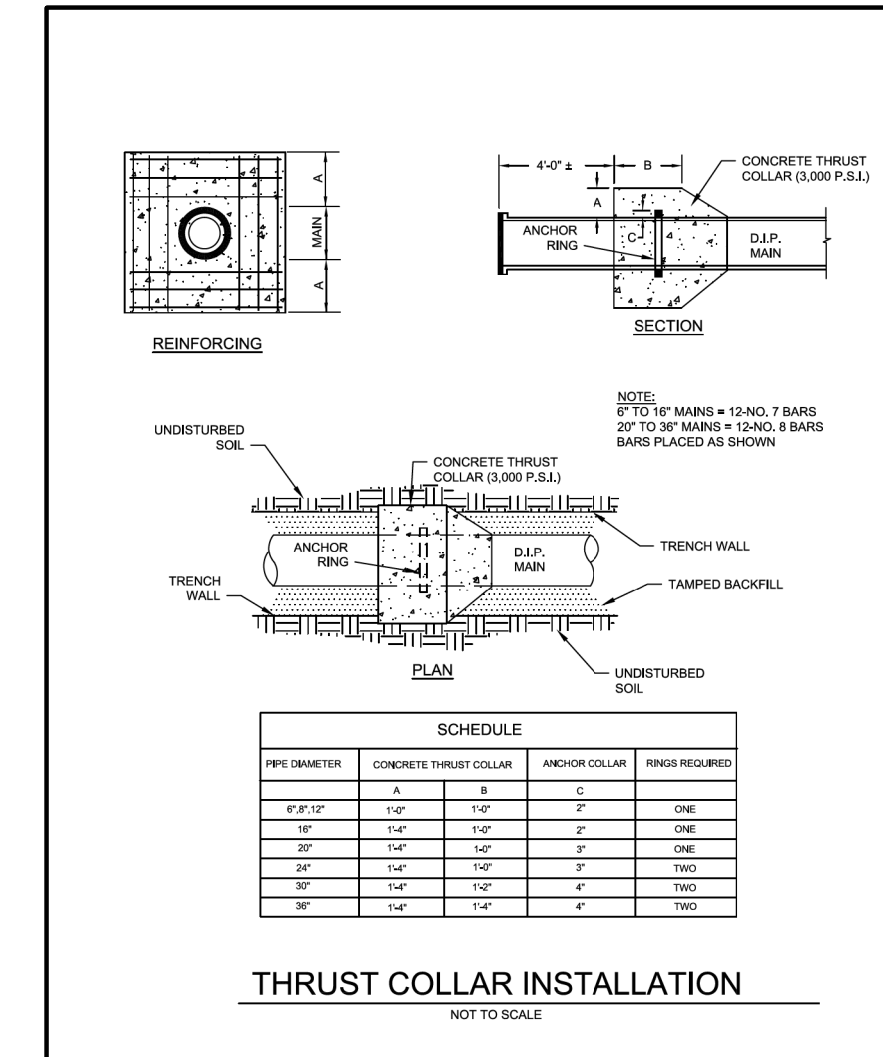

Drawn By:	Name:	Date:	JOHNSTON COUNTY Department of Public Utilities P.O. Box 2303 SHEPHERD, NC 27577	WATER STANDARD DETAIL Thrust Collar Installation	PAGE 9
-----------	-------	-------	--	---	--------

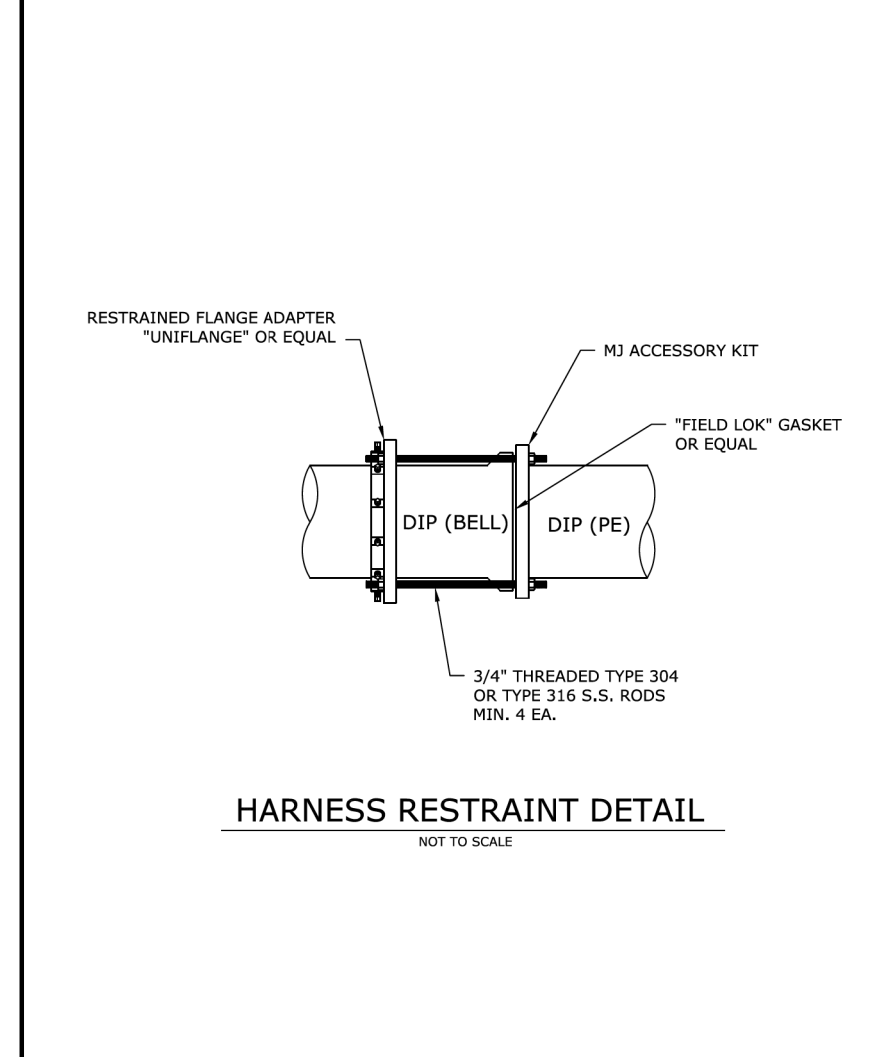

Drawn By:	Name:	Date:	JOHNSTON COUNTY Department of Public Utilities P.O. Box 2303 SHEPHERD, NC 27577	WATER STANDARD DETAIL Harness Restraint	PAGE 10
-----------	-------	-------	--	--	---------

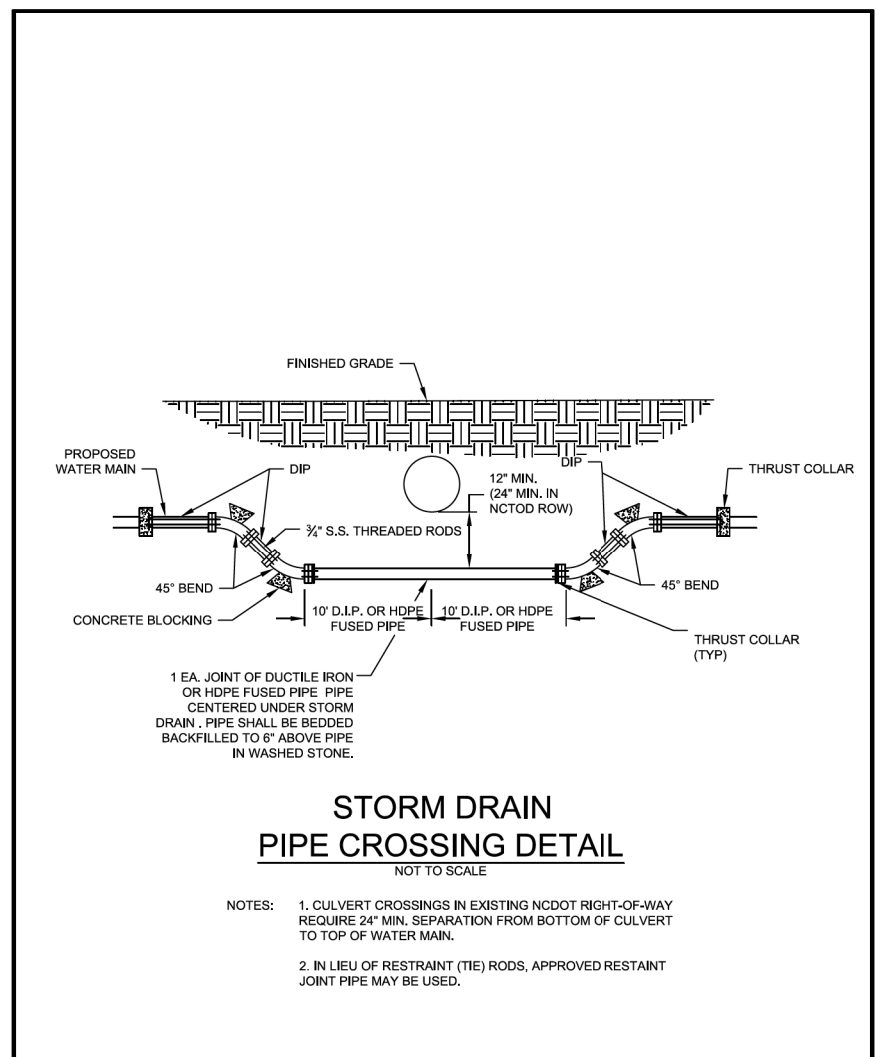

Drawn By:	Name:	Date:	JOHNSTON COUNTY Department of Public Utilities P.O. Box 2303 SHEPHERD, NC 27577	WATER STANDARD DETAIL Storm Pipe Crossing	PAGE 11
-----------	-------	-------	--	--	---------

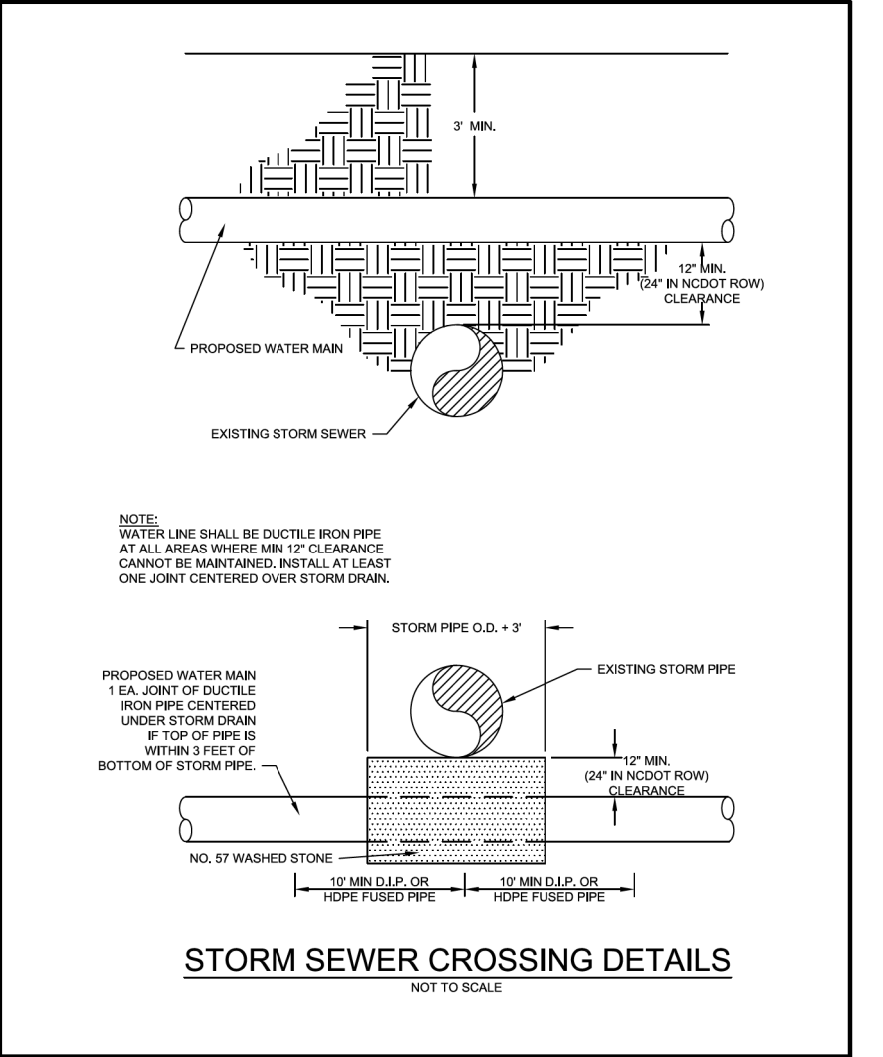

Drawn By:	Name:	Date:	JOHNSTON COUNTY Department of Public Utilities P.O. Box 2303 SHEPHERD, NC 27577	WATER STANDARD DETAIL Storm Sewer Crossing	PAGE 12
-----------	-------	-------	--	---	---------

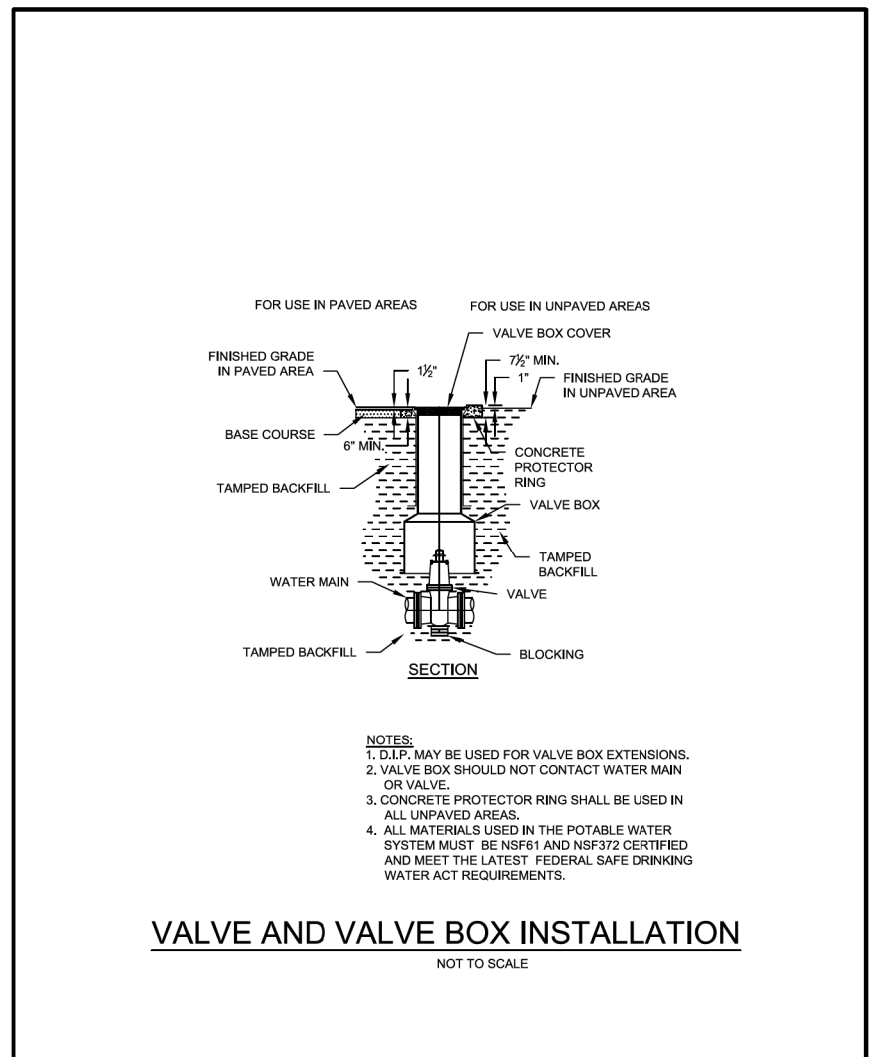

Drawn By:	Name:	Date:	JOHNSTON COUNTY Department of Public Utilities P.O. Box 2303 SHEPHERD, NC 27577	WATER STANDARD DETAIL Valve and Valve Box Installation	PAGE 13
-----------	-------	-------	--	---	---------

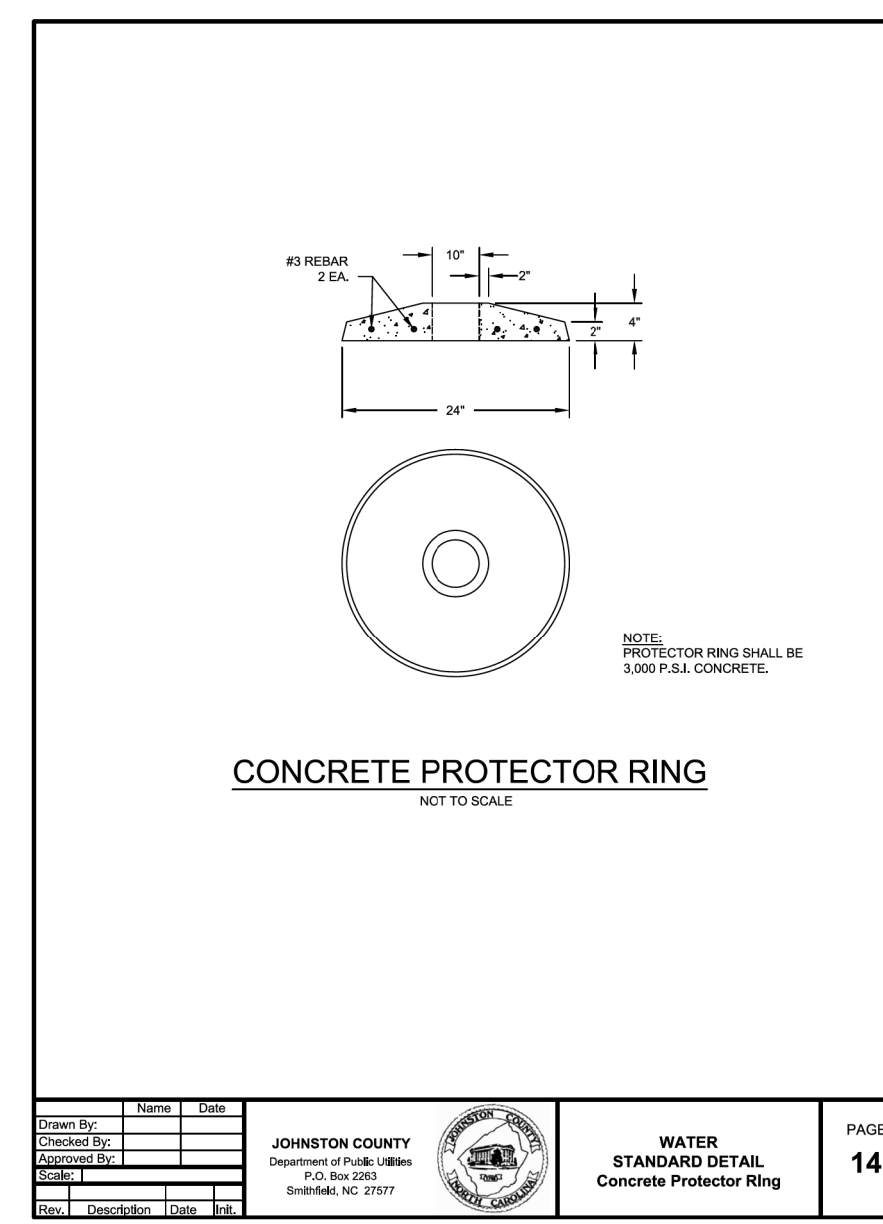

Drawn By:	Name:	Date:	JOHNSTON COUNTY Department of Public Utilities P.O. Box 2303 SHEPHERD, NC 27577	WATER STANDARD DETAIL Concrete Protector Ring	PAGE 14
-----------	-------	-------	--	--	---------

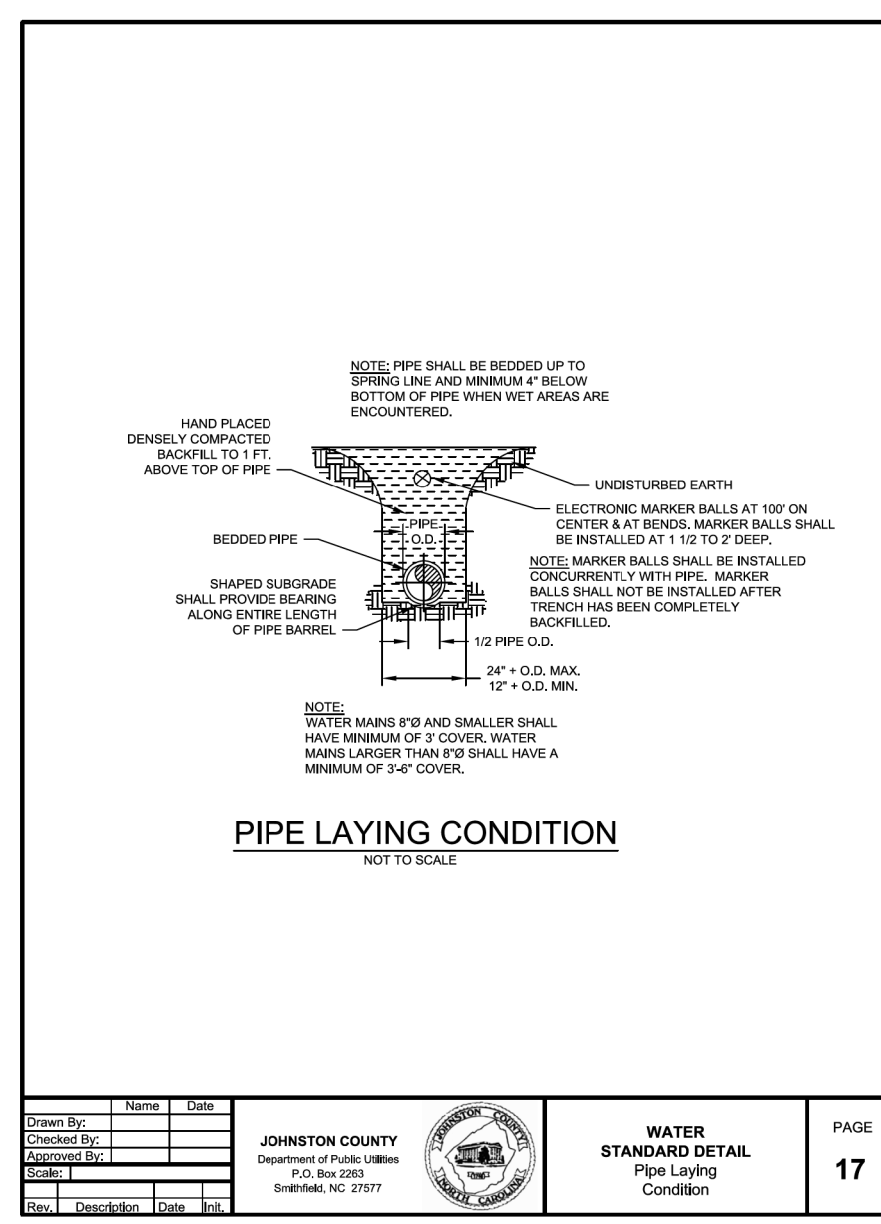

Drawn By:	Name:	Date:	JOHNSTON COUNTY Department of Public Utilities P.O. Box 2303 SHEPHERD, NC 27577	WATER STANDARD DETAIL Pipe Laying Condition	PAGE 17
-----------	-------	-------	--	--	---------

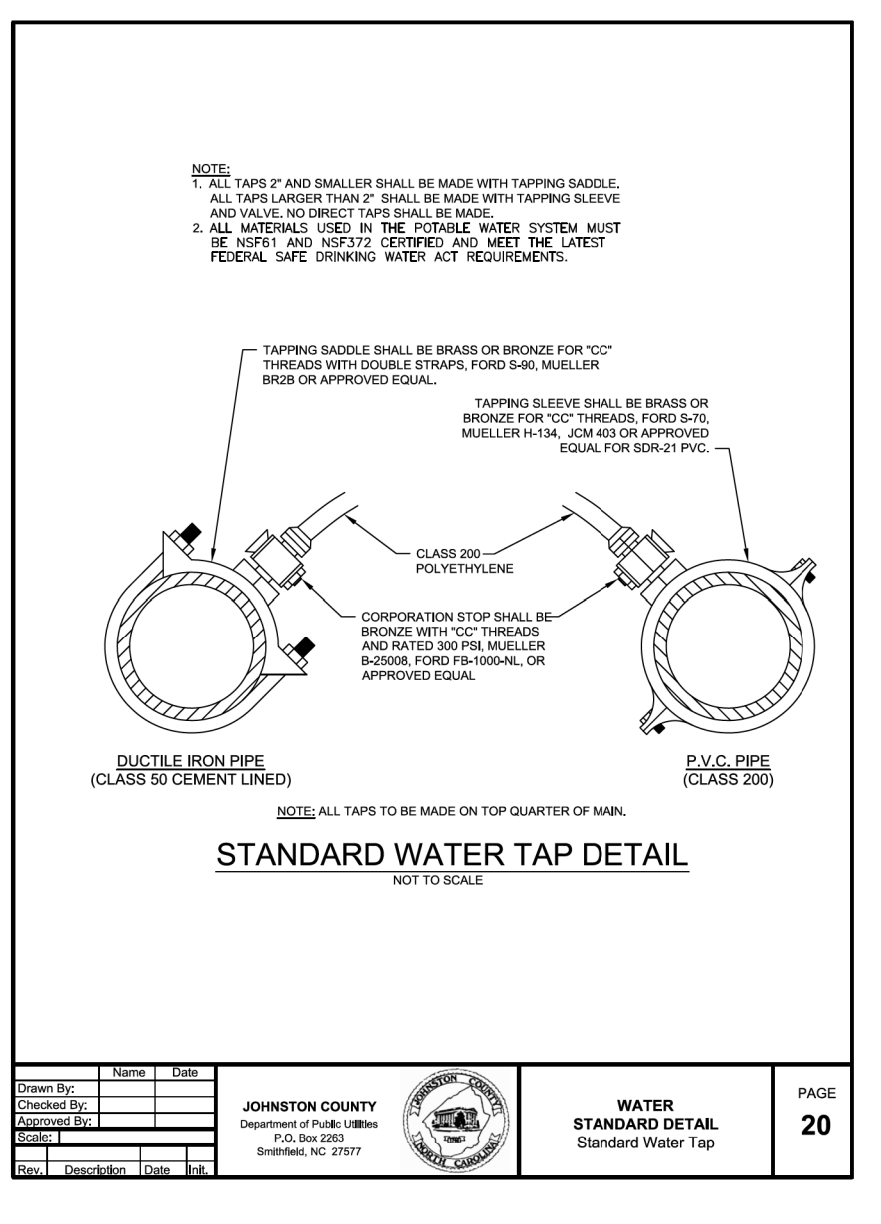

Drawn By:	Name:	Date:	JOHNSTON COUNTY Department of Public Utilities P.O. Box 2303 SHEPHERD, NC 27577	WATER STANDARD DETAIL Standard Water Tap	PAGE 20
-----------	-------	-------	--	---	---------

REVISIONS

11/20/2019 UC3A.dgn
PLOT DRIVER: \$PLOTDRVL\$\$
PEN TABLE: \$PENLBLE\$\$