

Project: 15BPR.20

STATE OF NORTH CAROLINA
DIVISION OF HIGHWAYS

HENDERSON AND POLK COUNTIES

LOCATION: I-26 /US 74 FROM US 25 TO SOUTH CAROLINA STATE LINE

TYPE OF WORK: FIBER, CCTV CAMERA AND DYNAMIC MESSAGE SIGN INSTALLATIONS

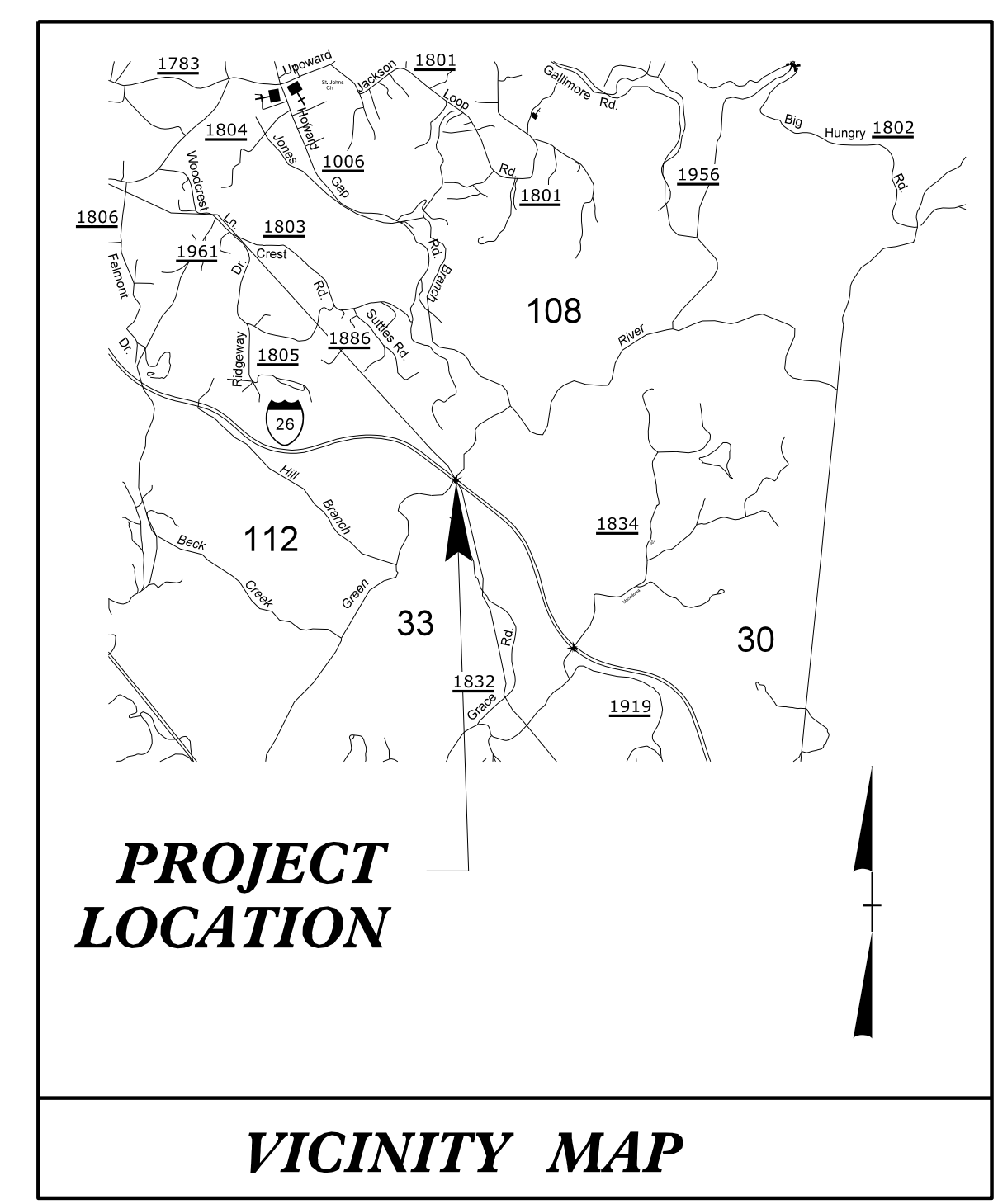

VICINITY MAP

NOT TO SCALE

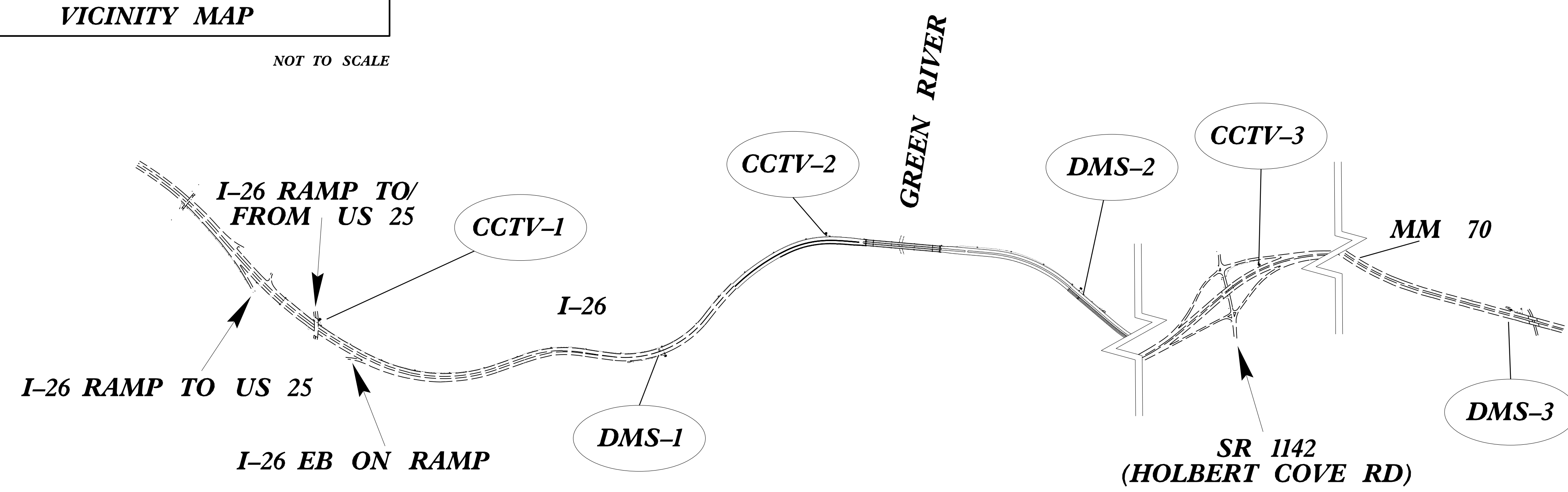
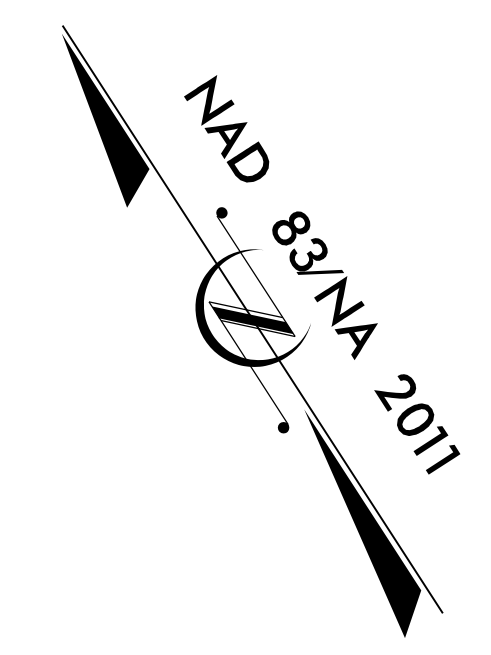
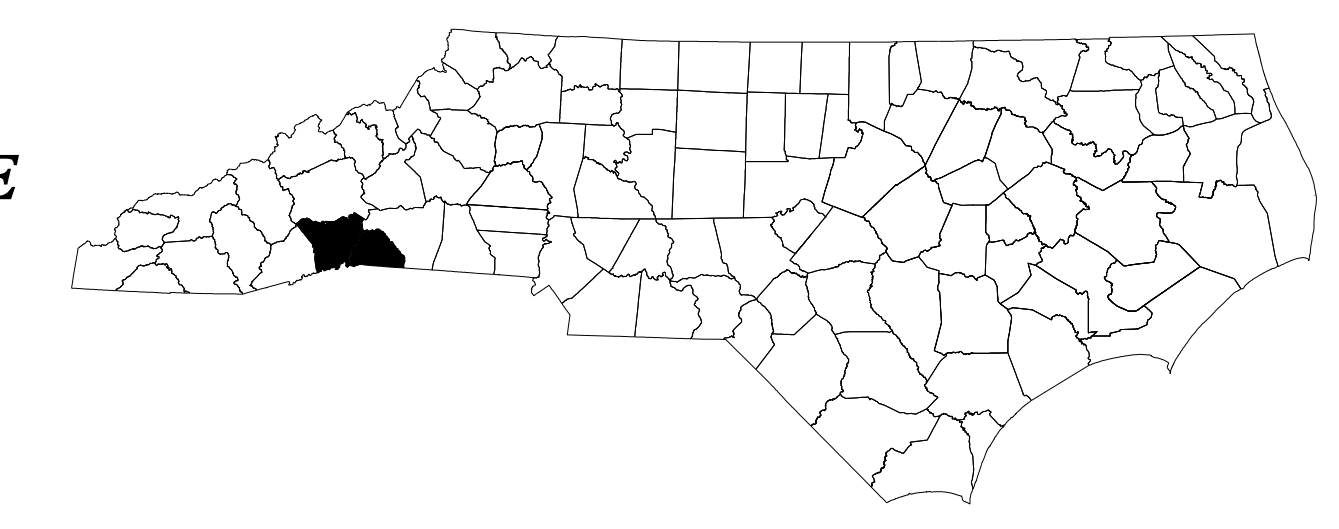

AECOM
NC Firm License No.: F-0342
701 Corporate Center Drive
Suite 475 Raleigh, NC 27607
Phone: 919-854-6200

Refer to "Roadway Standard Drawings NCDOT" dated January 2018 and "Standard Specifications for Roads and Structures" dated January 2018.

Sheet #	Index of Plans	Location/Description
ITS-1	Title Sheet	
ITS-2	Construction Notes	
ITS-3 to ITS-15	Communications Cable and Conduit Routing Plans	
ITS-16 to ITS-19	Splice Plans	
ITS-20 to ITS-25	Elevation Views	
ITS-26 to ITS-31	Typical Details	

NCDOT ITS & SIGNALS UNIT
Contacts:
Neil Avery - ITS Engineer
Andrew Skuce - ITS Design Engineer

HIGHWAY DIVISION 14
Contacts:
Brian Burch, PE - Division Engineer
Steve Buchanan - Division Traffic Engineer

Prepared for the Office of:
DIVISION OF HIGHWAYS
TRANSPORTATION MOBILITY AND SAFETY DIVISION

750 N. Greenfield Parkway, Garner, NC 27529

I:\2018\170-1-26-GreenRiver-T02\900-CAD-GIS\910-CAD\70-NCDDOT-TIP\Traffic\Signals\Design\Signals\ITS\ITS Title Sheet.dgn
1/2/2020
1:56:58 PM
michael.lcavanagh

- 1 INSTALL 3-WIRE COPPER SERVICE ENTRANCE CONDUCTORS
- 2 INSTALL 4-WIRE COPPER FEEDER CONDUCTORS
- 3 INSTALL 3-WIRE COPPER FEEDER CONDUCTORS
- 4 INSTALL SMFO CABLE
- 5 INSTALL ETHERNET CABLE
- 6 INSTALL FIBER OPTIC DROP CABLE
- 7 INSTALL TRACER WIRE
- 8 TRENCH
- 9 INSTALL FIBERGLASS CONDUIT
- 10 INSTALL RIGID, GALVANIZED STEEL CONDUIT
- 11 INSTALL RIGID, GALVANIZED STEEL RISER WITH WEATHERHEAD
- 12 INSTALL RIGID, GALVANIZED STEEL RISER WITH FIBER OPTIC CABLE SEAL
- 13 INSTALL OUTER-DUCT POLYETHYLENE CONDUIT
- 14 INSTALL POLYETHYLENE CONDUIT
- 15 DIRECTIONAL DRILL CONDUIT
- 16 BORE AND JACK CONDUIT
- 17 INSTALL CABLE(S) IN EXISTING CONDUIT
- 18 INSTALL CABLE(S) IN NEW CONDUIT
- 19 INSTALL CABLE(S) IN EXISTING RISER
- 20 INSTALL CABLE(S) IN NEW RISER
- 21 INSTALL CABLE(S) IN EXISTING CONDUIT STUB-OUTS
- 22 INSTALL NEW CONDUIT INTO EXISTING CABINET BASE (USE EXISTING CONDUIT STUB-OUTS WHEN AVAILABLE)
- 23 INSTALL NEW RISER INTO EXISTING CABINET BASE (USE EXISTING CONDUIT STUB-OUTS WHEN AVAILABLE)
- 24 INSTALL NEW CONDUIT INTO EXISTING POLE MOUNTED CABINET
- 25 INSTALL NEW RISER INTO EXISTING POLE MOUNTED CABINET
- 26 MODIFY EXISTING INTERCONNECT CENTER /SPLICE ENCLOSURE
- 27 INSTALL NEW FIBER OPTIC TRANSCEIVER
- 28 INSTALL INTERCONNECT CENTER, PATCH PANEL, JUMPERS AND FUSION SPLICE CABLE IN CABINET
- 29 INSTALL UNDERGROUND SPLICE ENCLOSURE
- 30 INSTALL AERIAL SPLICE ENCLOSURE
- 31 INSTALL POLE MOUNTED SPLICE CABINET
- 32 INSTALL BASE MOUNTED SPLICE CABINET
- 33 REMOVE EXISTING SPLICE CABINET

- 34 INSTALL CABINET FOUNDATION
- 35 INSTALL CCTV CAMERA POLE MOUNTED CABINET
- 36 INSTALL CCTV CAMERA ASSEMBLY
- 37 INSTALL CCTV CAMERA WOOD POLE (60 FOOT)
- 38 INSTALL CCTV CAMERA METAL POLE AND FOUNDATION
- 39 INSTALL LIMITED ACCESS FACILITIES - JUNCTION BOX (STANDARD SIZE 16" x 10" x 10") WITH CONCRETE COLLAR
- 40A INSTALL LIMITED ACCESS FACILITIES - JUNCTION BOX (OVERSIZED 28" x 15" x 22") WITH CONCRETE COLLAR
- 40B INSTALL LIMITED ACCESS FACILITIES - JUNCTION BOX (SPECIAL OVERSIZED 33" x 22" x 22") WITH CONCRETE COLLAR
- 40C BRIDGE MOUNTED JUNCTION BOX
- 40D ELECTRONIC MARKER BALL
- 41 REMOVE EXISTING JUNCTION BOX
- 42 INSTALL WOOD POLE
- 43 REMOVE EXISTING WOOD POLE
- 44 INSTALL AERIAL GUY ASSEMBLY
- 45 INSTALL STANDARD GUY ASSEMBLY
- 46 INSTALL SIDEWALK GUY ASSEMBLY
- 47 INSTALL MESSENGER CABLE
- 48A REMOVE EXISTING COMMUNICATIONS AND MESSENGER CABLE
- 48B REMOVE EXISTING COMMUNICATIONS CABLE
- 49 BACK PULL EXISTING COMMUNICATIONS CABLE
- 50 INSTALL TELEPHONE SERVICE
- 51 INSTALL CABLE STORAGE RACKS (SNOW SHOES) AND STORE 100 FEET OF CABLE
- 52A INSTALL DELINEATOR MARKER
- 52B INSTALL JUNCTION BOX MARKER
- 53 STORE 50 FEET OF COMMUNICATIONS CABLE
- 54 LASH CABLE(S) TO EXISTING COMMUNICATIONS CABLE
- 55 LASH CABLE(S) TO EXISTING MESSENGER CABLE
- 56 LASH CABLE(S) TO NEW MESSENGER CABLE
- 57 MODIFY EXISTING ELECTRICAL SERVICE
- 58A INSTALL NEW ELECTRICAL SERVICE
- 58B INSTALL EQUIPMENT CABINET DISCONNECT
- 59 INSTALL NEW ETHERNET EDGE SWITCH
- 60 BOND TRACER WIRE TO EQUIPMENT GROUND BUS
- 61 DO NOT BOND TRACER WIRE TO EQUIPMENT GROUND BUS
- 62 BOND RISER AND MESSENGER CABLE TO POLE GROUND
- 63 BOND RISER TO POLE GROUND
- 64 BOND MESSENGER CABLE TO POLE GROUND
- 65 INSTALL HEAT SHRINK TUBING RETROFIT KIT

- 66 INSTALL MOLDABLE DUCT SEAL
- 67 SLACK SPAN
- 68 INSTALL DMS
- 69 INSTALL DMS PEDESTAL STRUCTURE
- 70 INSTALL CELL MODEM (FURNISHED BY OTHERS)

LEGEND

- NEW FIBER OPTIC COMMUNICATIONS CABLE
- NEW TWISTED PAIR COMMUNICATIONS CABLE
- EXISTING COMMUNICATIONS CABLE
- EXISTING COMMUNICATIONS CABLE TO BE REMOVED
- NEW AERIAL GUY ASSEMBLY
- NEW CONDUIT
- EXISTING CONDUIT
- NEW DIRECTIONAL DRILLED CONDUIT
- NEW JUNCTION BOX
- EXISTING JUNCTION BOX
- PROPOSED DMS
- NEW WOOD POLE
- PORTABLE CHANGABLE MESSAGE SIGN FOR INCIDENT MANAGEMENT
- EXISTING WOOD POLE
- AERIAL SPLICE ENCLOSURE
- UNDERGROUND SPLICE ENCLOSURE
- PORTABLE CCTV CAMERA AND TRAILER
- NEW METAL POLE
- EXISTING HIGHWAY ADVISORY RADIO
- EXISTING METAL POLE
- ELECTRICAL SERVICE
- NEW CCTV ASSEMBLY
- EXISTING CCTV ASSEMBLY
- NEW STANDARD GUY ASSEMBLY
- 6" x 6" WOOD POST
- EXISTING GUY ASSEMBLY
- EXISTING TRANSFORMER
- NEW SIDEWALK GUY ASSEMBLY
- NEW SUPPLEMENTAL EQUIPMENT CABINET DISCONNECT
- SIGNAL INVENTORY NUMBER
- NEW EQUIPMENT CABINET

CONSTRUCTION NOTE SYMBOLOGY KEY

- INDICATES NUMBER OF CABLES, LOOPS, ETC.
- INDICATES NUMBER OF FIBERS PER CABLE, TWISTED PAIRS PER CABLE, ETC.
- INDICATES NUMBER OF RISER(S)/CONDUIT(S)
- INDICATES DIAMETER OF RISER(S)/CONDUIT(S) (INCH)

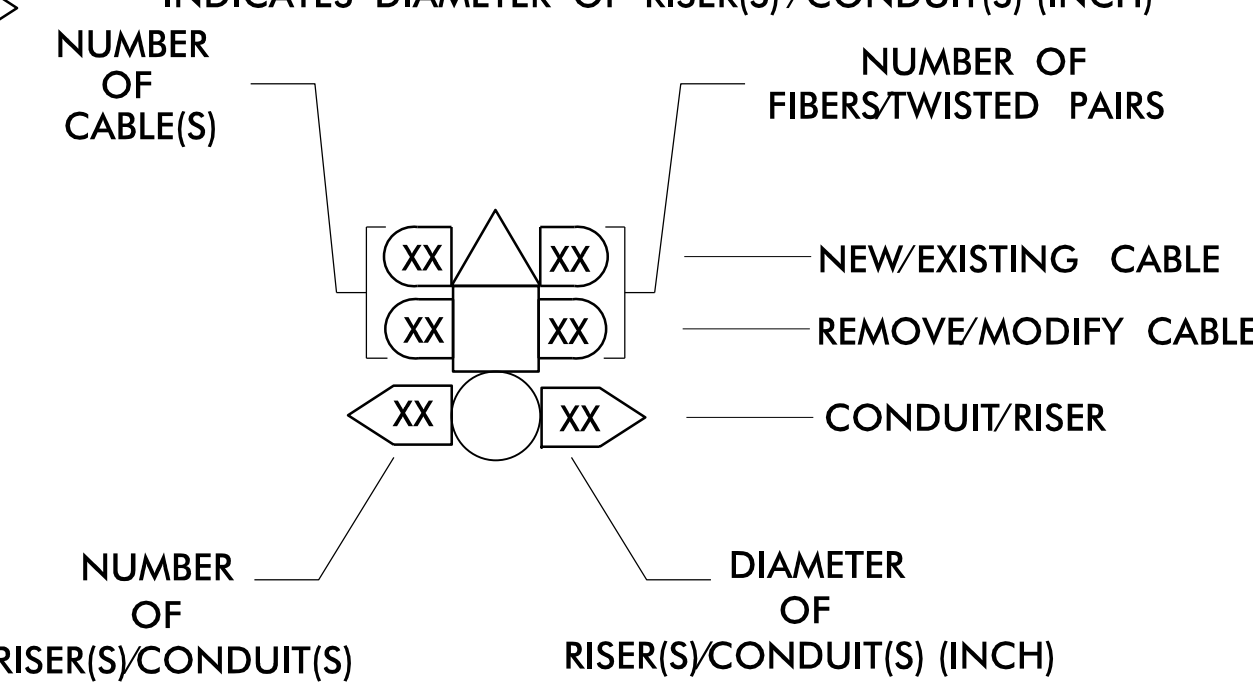

DOCUMENT NOT CONSIDERED FINAL UNLESS ALL SIGNATURES COMPLETED

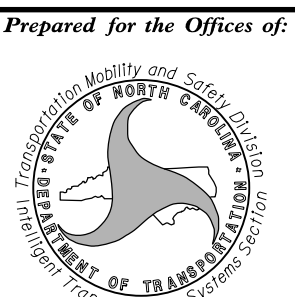
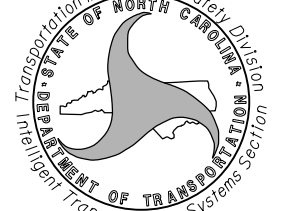
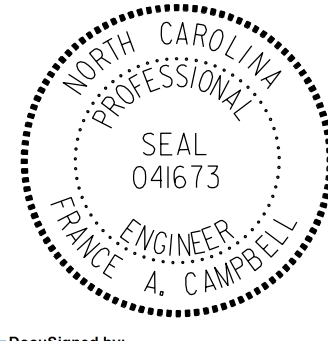
 <p>Prepared for the Offices of: <div style="display: flex; justify-content: center; align-items: center;">  </div> </p>	<p>Construction Notes</p> <p>Division 14 Henderson Co.</p>										
<p>750 N. Greenfield Pkwy., Garner, NC 27529</p>	<p>PLAN DATE: December 2020 REVIEWED BY: S. W. Cox</p> <p>PREPARED BY: M. P. Cavanaugh REVIEWED BY: F. A. Campbell</p>	<p>DocuSigned by: Frances Campbell 12/8/2020</p> <p style="font-size: small;">110048E200847C CADD Filename:</p>									
<p>SCALE</p> <p>0 NA</p> <p style="font-size: small;">N.T.S.</p>	<table border="1" style="width: 100%; border-collapse: collapse; font-size: x-small;"> <tr> <th>REVISIONS</th> <th>INIT.</th> <th>DATE</th> </tr> <tr> <td> </td> <td> </td> <td> </td> </tr> <tr> <td> </td> <td> </td> <td> </td> </tr> </table>		REVISIONS	INIT.	DATE						
REVISIONS	INIT.		DATE								
<p>NC Firm License No.: F-0342 701 Corporate Center Drive Suite 475 Raleigh, NC 27607 Phone: 919-854-6200</p>											

12/17/2020 P:\460581710-126_Greenfield-CAD_01\S4910-CAD\WTO_NCDOT-11P\Traffic\cables\cables.dwg 1/26_11S_P5H2.dgn michael.cavanaugh

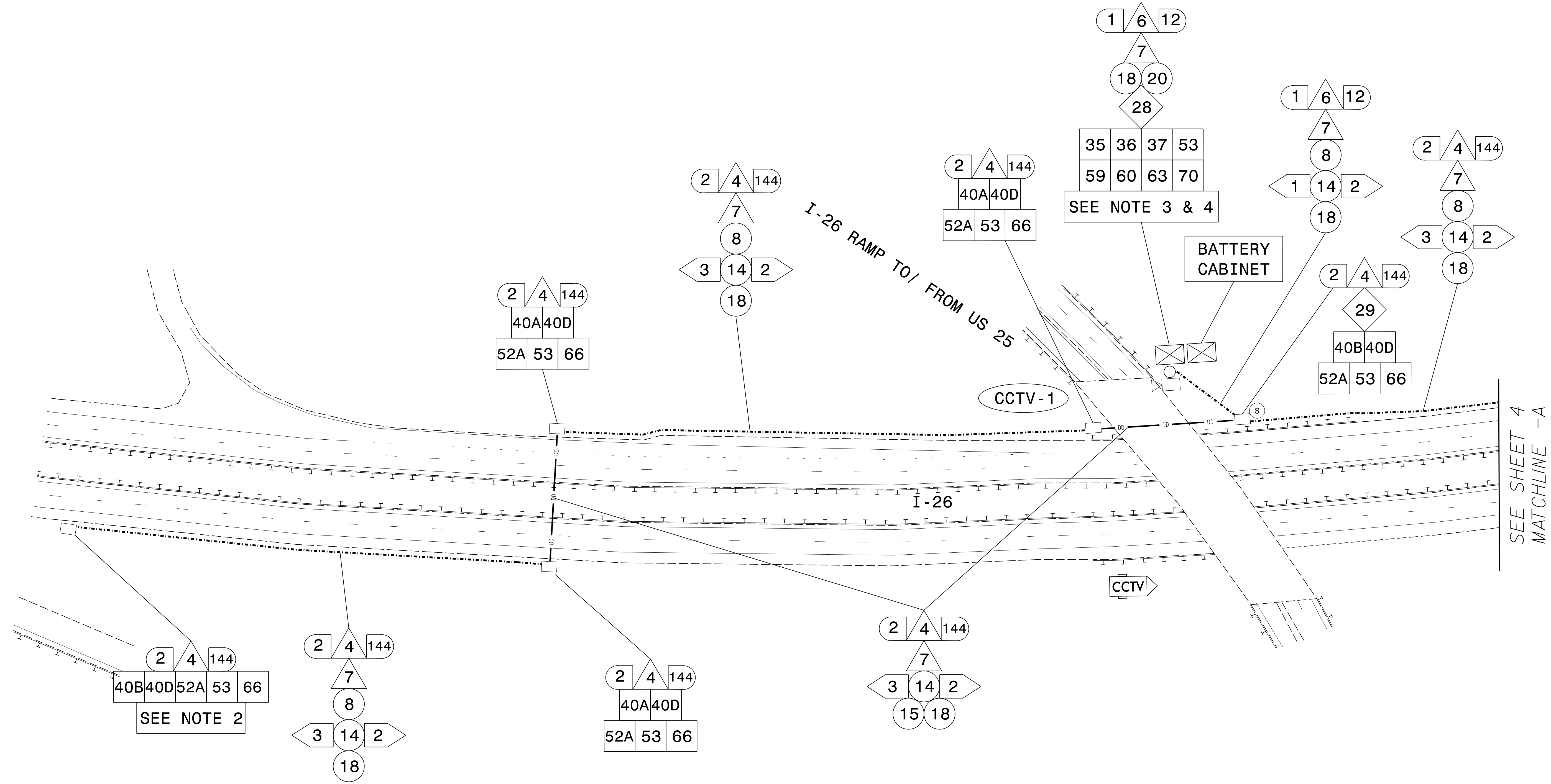

CONDUIT LAYOUT
 BLUE = 144 FO (SPARE)
 ORANGE = 144 FO (ACTIVE)
 GREEN = SPARE
 RED = POWER

NOTES:

1. USE 144 FIBER IN ORANGE DUCT FOR ALL DEVICES ON THIS PROJECT.
2. CAP AND SEAL FIBER IN JUNCTION BOX. COIL 50 FEET OF FIBER.
3. INSTALL SOLAR POWERED ELECTRICAL SERVICE.
4. TERMINATE FIBER TO ETHERNET SWITCH, BUT DO NOT CONNECT ETHERNET SWITCH TO FIELD DEVICE. CONNECT FIELD DEVICE TO THE CELLULAR MODEM.

12/7/2020 P:\60587170-1-26_Greenfield_Pkwy_750-26_Greenfield_1-26_CAD\WTO_NCDOT_TIP\Traffic\c45\c45\c45\c45\c45\ITS\1-26_ITS_P5H5.dgn michael.covernaugh



Communication Cable and Conduit Routing Plans	
Division 14 Henderson Co.	PLAN DATE: December 2020
PREPARED BY: M. P. Cavanaugh	REVIEWED BY: S. W. Cox
REVISIONS	INIT. DATE

DOCUMENT NOT CONSIDERED FINAL UNLESS ALL SIGNATURES COMPLETED

DocuSigned by: France Campbell 12/8/2020
 119D84E20887C
 CADD File name: _____

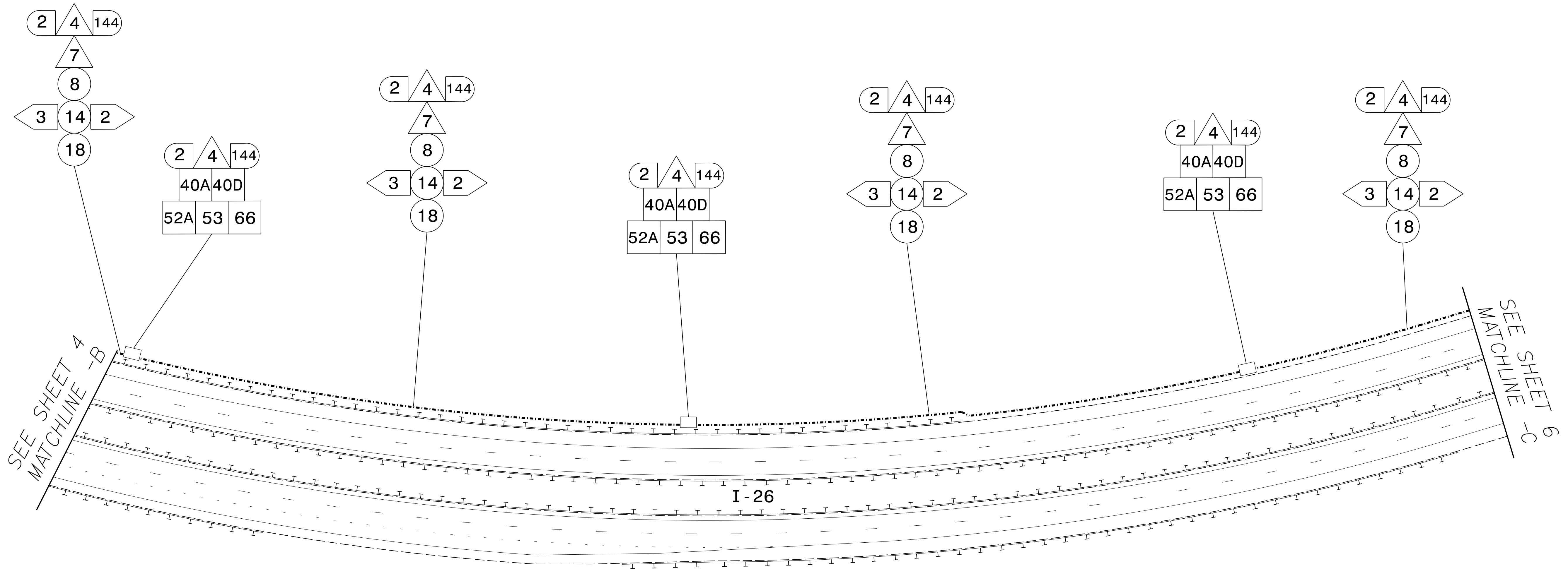

SEE SHEET 4
MATCHLINE -B

SEE SHEET 6
MATCHLINE -C

CONDUIT LAYOUT
 BLUE = 144 FO (SPARE)
 ORANGE = 144 FO (ACTIVE)
 GREEN = SPARE
 RED = POWER

NOTES:
 1. USE 144 FIBER IN ORANGE DUCT FOR ALL DEVICES ON THIS PROJECT.

DOCUMENT NOT CONSIDERED FINAL UNLESS ALL SIGNATURES COMPLETED

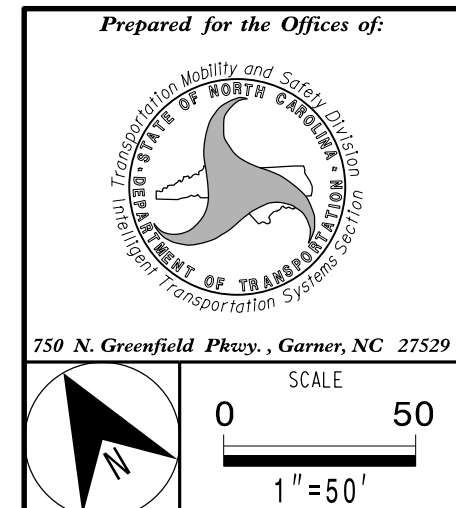

Prepared for the Offices of:

Communication Cable and Conduit Routing Plans

Division 14 Henderson Co.

PLAN DATE: December 2020 REVIEWED BY: S. W. Cox

PREPARED BY: M. P. Cavanaugh REVIEWED BY: F. A. Campbell

REVISIONS	INIT.	DATE

DocuSigned by:
 France Campbell 12/8/2020
 119D84E208847C
 CADD Filename:

AECOM
 NC Firm License No.: F-0342
 701 Corporate Center Drive
 Suite 475 Raleigh, NC 27607
 Phone: 919-854-6200

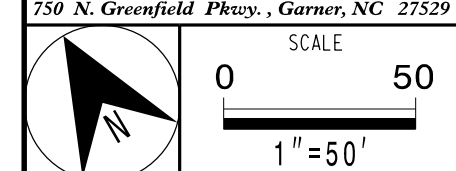

12/17/2020
P:\460587170-1-26_Greenfield_Pkwy-126_Greenfield_CAD\MTO_NCDOT_TIP\Traffic\cns\cns\p1s\p1s\1-26_ITS_P5H7.dgn
michael.cavanaugh

DRAWING 1

DRAWING 2

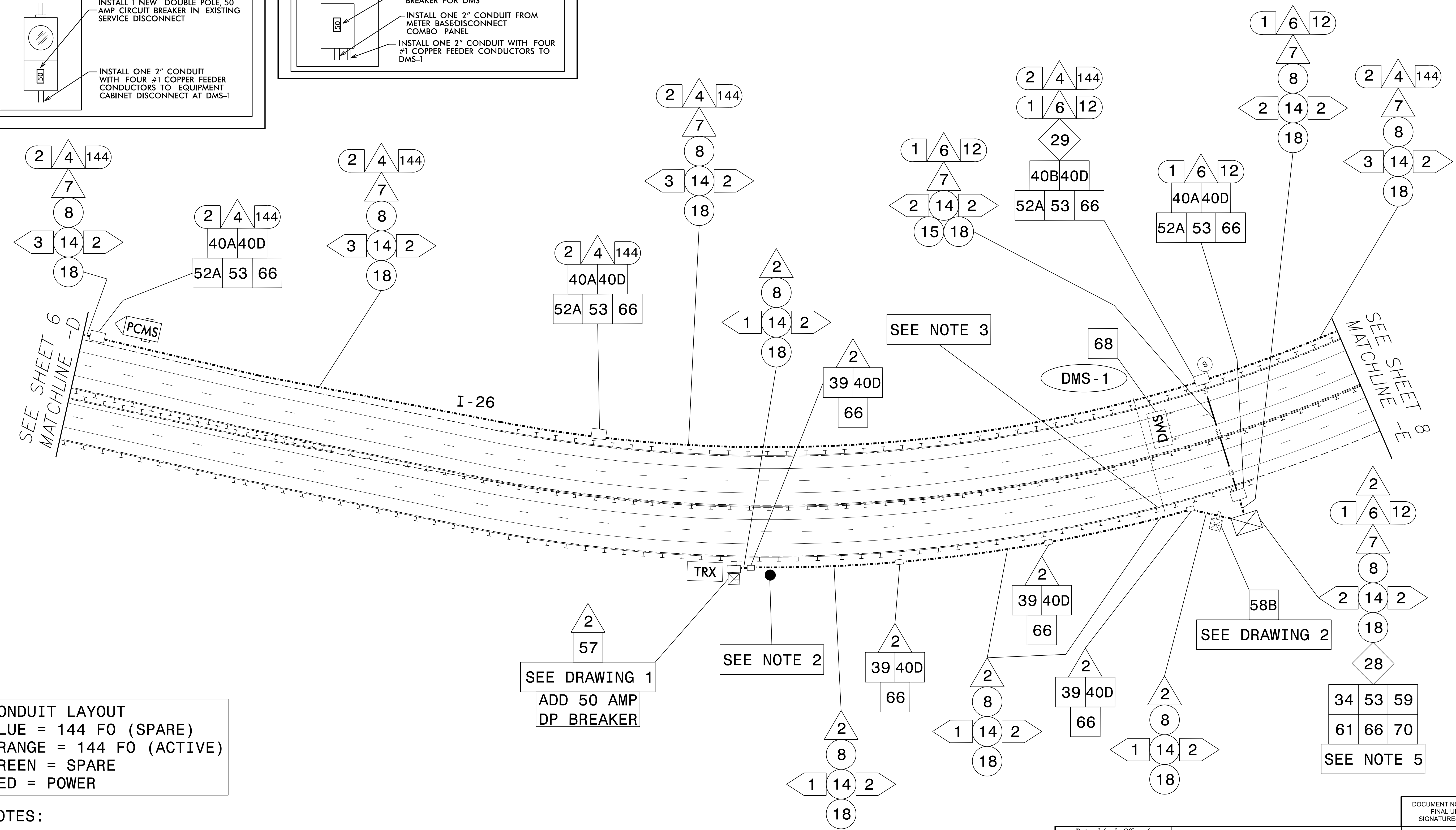
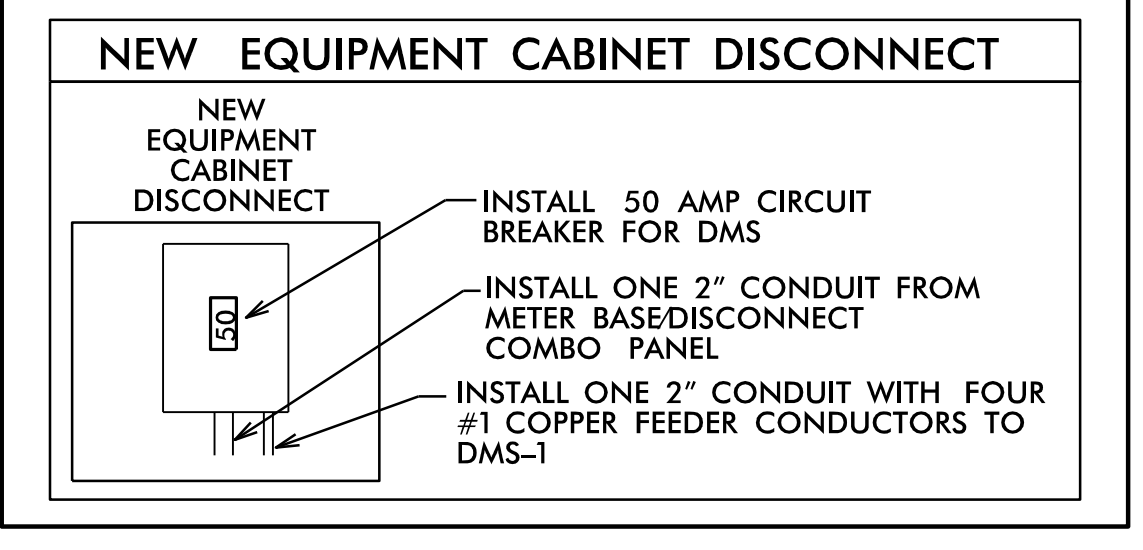
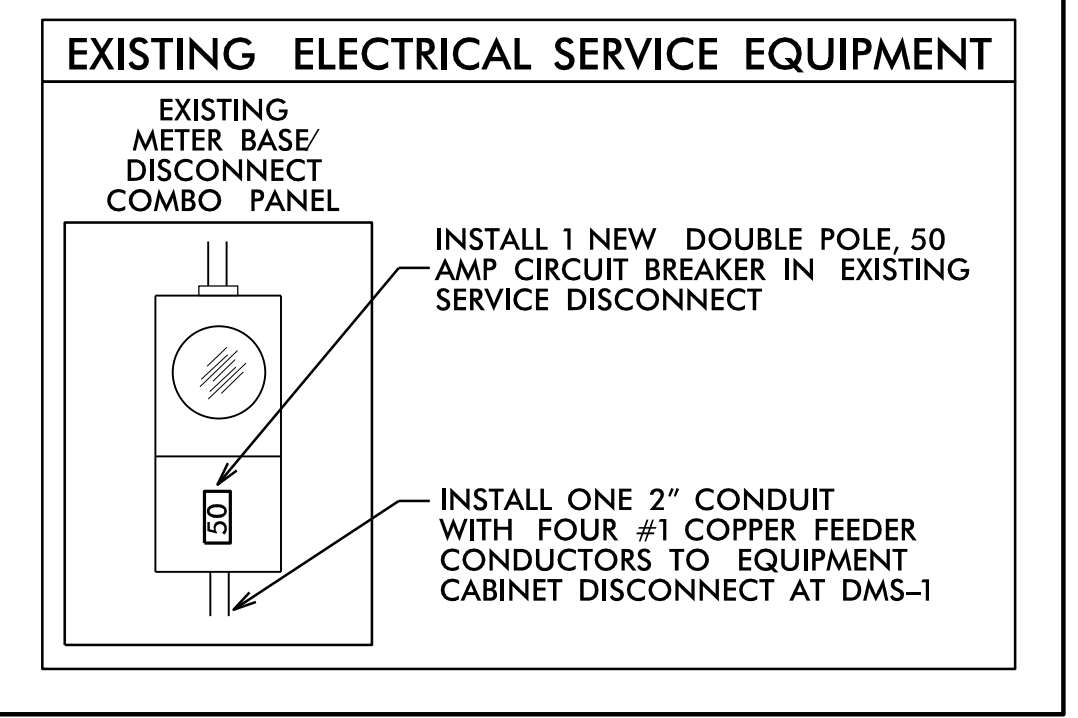

CONDUIT LAYOUT
 BLUE = 144 FO (SPARE)
 ORANGE = 144 FO (ACTIVE)
 GREEN = SPARE
 RED = POWER

- NOTES:**
1. USE 144 FIBER IN ORANGE DUCT FOR ALL DEVICES ON THIS PROJECT.
 2. EXISTING WOOD POLE FOR TRUCK SPEED DETECTION SYSTEM (TO REMAIN).
 3. EXISTING GUARDRAIL STOPS AT OVERHEAD STRUCTURE, INSTALL AN ADDITIONAL 100'.
 4. TERMINATE FIBER TO ETHERNET SWITCH, BUT DO NOT CONNECT ETHERNET SWITCH TO THE FIELD DEVICE. CONNECT FIELD DEVICE TO THE CELLULAR MODEM.

2
57
SEE DRAWING 1
ADD 50 AMP
DP BREAKER

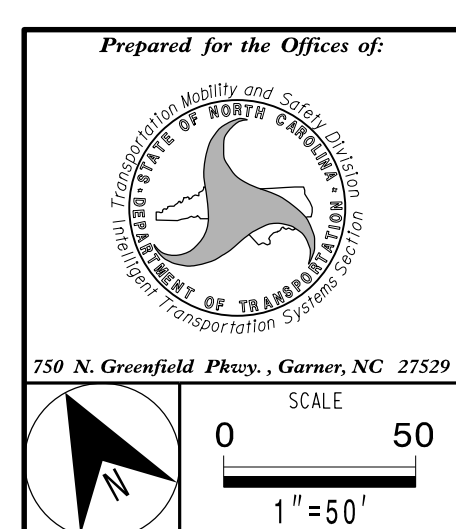

Communication Cable and Conduit Routing Plans

Division 14 Henderson Co.

PLAN DATE: December 2020 REVIEWED BY: S. W. Cox

PREPARED BY: M. P. Cavanaugh REVIEWED BY: F. A. Campbell

REVISIONS	INIT.	DATE

SCALE: 0 50
1" = 50'

DOCUMENT NOT CONSIDERED FINAL UNLESS ALL SIGNATURES COMPLETED

Designed by: *Francis Campbell* 12/8/2020
 CADD File name:

12/17/2020
 P:\060581710-1-26_Greenfield_Pkwy-750-4000-CAD\DWG\10_NCDOT_TIP\Traffic\cables\cable\cable\10-26_ITS_P519.dgn
 michael.cavanaugh

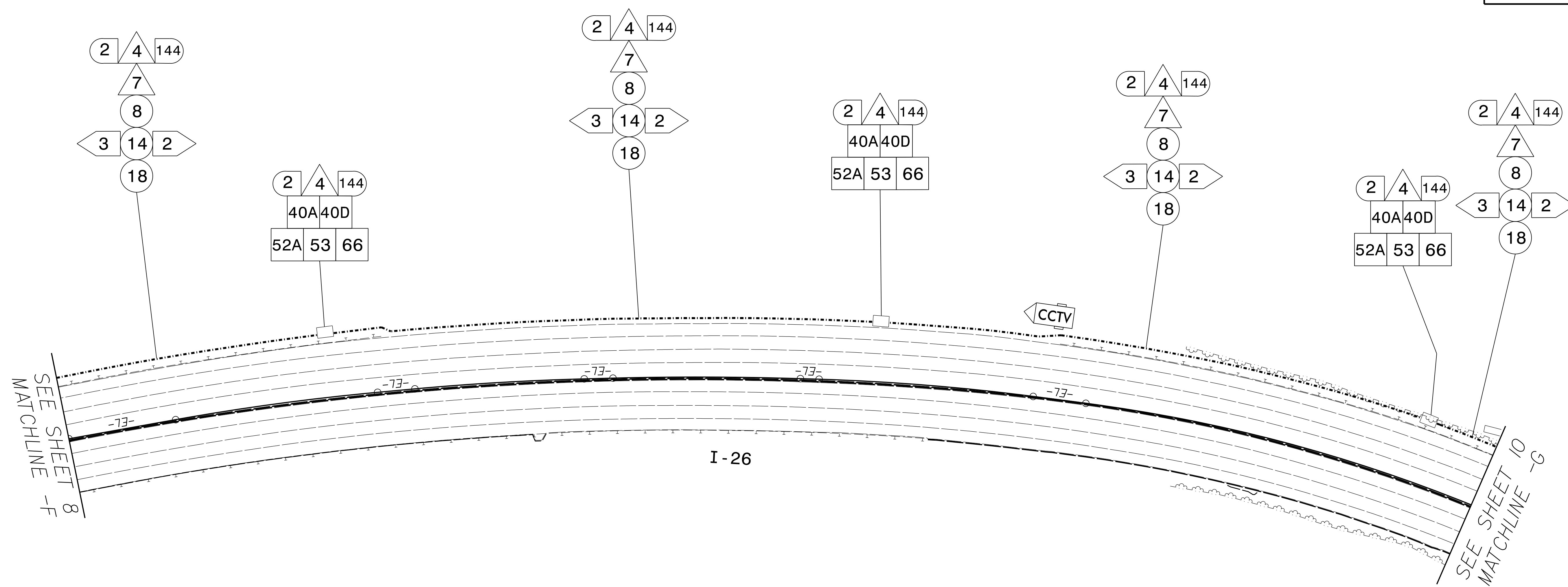

CONDUIT LAYOUT
 BLUE = 144 FO (SPARE)
 ORANGE = 144 FO (ACTIVE)
 GREEN = SPARE
 RED = POWER

NOTES:

- 1. USE 144 FIBER IN ORANGE DUCT FOR ALL DEVICES ON THIS PROJECT.

12/7/2020
 P:\60587170-1-26_Greenfield_Pkcsy-Garner,NC-27529\CAD\W70_NCDOT_TIP\Traffic\GIS\0051\0051.dgn
 michael.cavanaugh

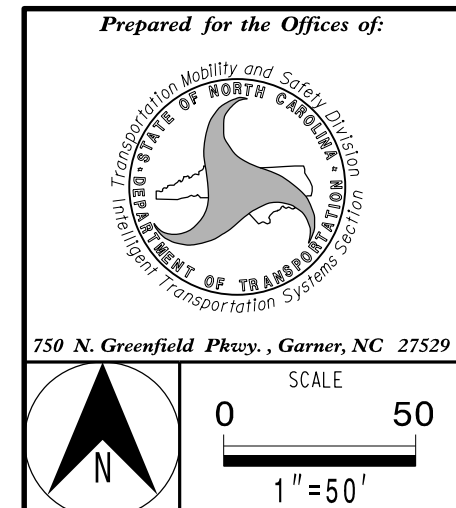

Communication Cable and Conduit Routing Plans

Division 14 Henderson Co.

PLAN DATE: December 2020 REVIEWED BY: S. W. Cox

PREPARED BY: M. P. Cavanaugh REVIEWED BY: F. A. Campbell

REVISIONS	INIT.	DATE

DOCUMENT NOT CONSIDERED FINAL UNLESS ALL SIGNATURES COMPLETED

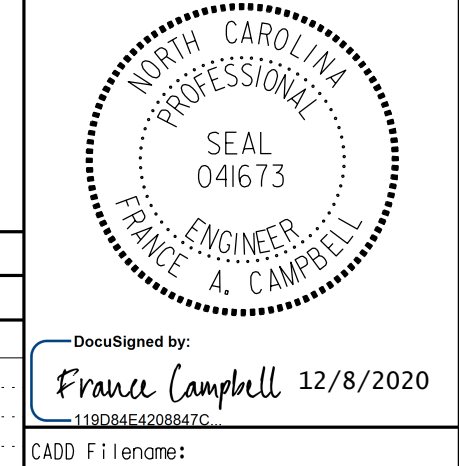

DocuSigned by:
 France Campbell 12/8/2020
 119D84E208847C
 CADD Filename:

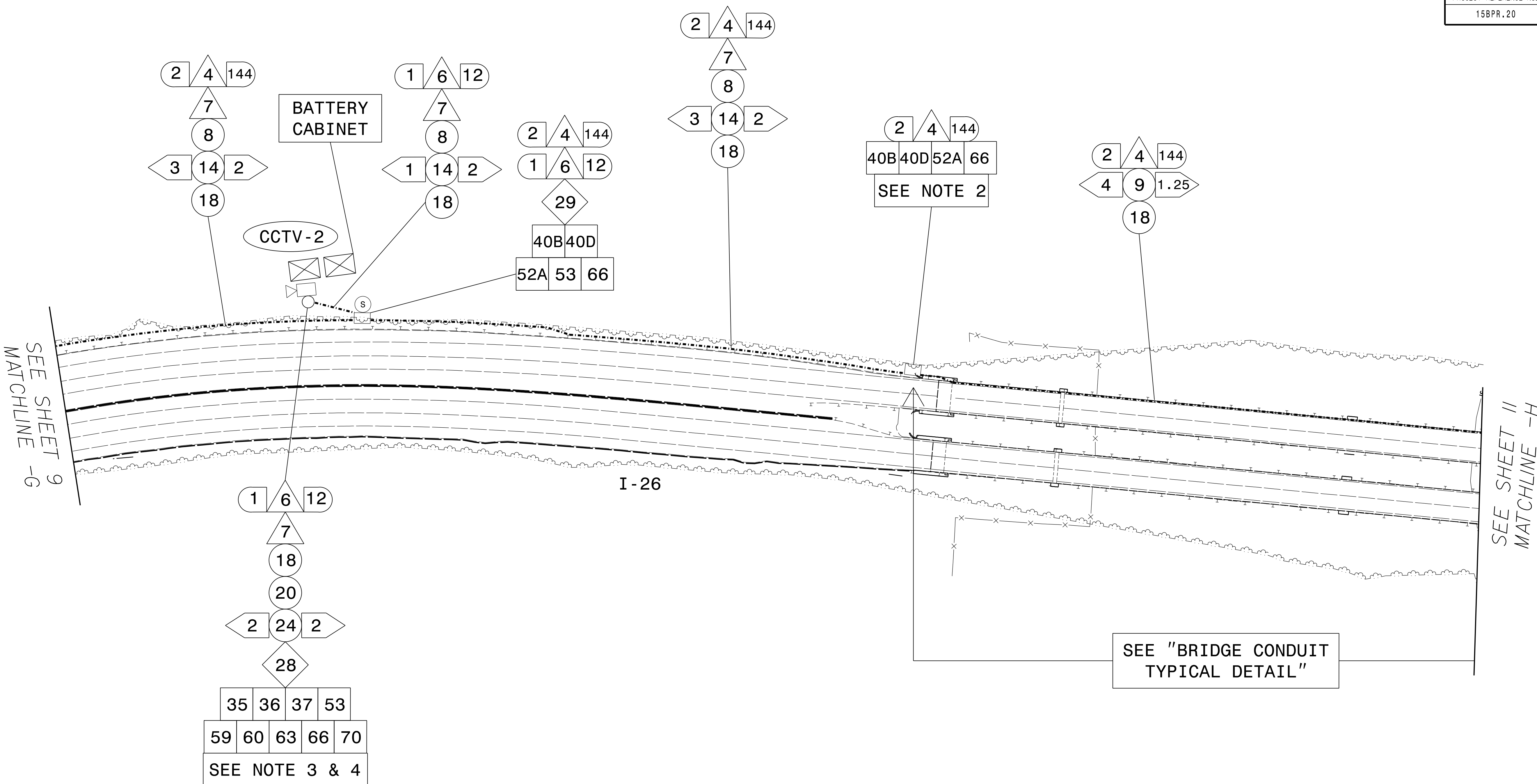

CONDUIT LAYOUT
 BLUE = 144 FO (SPARE)
 ORANGE = 144 FO (ACTIVE)
 GREEN = SPARE
 RED = POWER

NOTES:

- 1. USE 144 FIBER IN ORANGE DUCT FOR ALL DEVICES ON THIS PROJECT.
- 2. STORE 50 FEET OF COMMUNICATION CABLE.
- 3. INSTALL SOLAR POWERED ELECTRICAL SERVICE.
- 4. TERMINATE FIBER TO ETHERNET SWITCH, BUT DO NOT CONNECT ETHERNET SWITCH TO FIELD DEVICE. CONNECT FIELD DEVICE TO THE CELLULAR MODEM.

12/7/2020
P:\06387176-1-26_Greenfield_Plan\1-26_Greenfield_CADD\10_CADD\10_NCDOT_TIP\Traffic\CS\gpa\is\00es\gpa\is\1-26 ITS\1-26 ITS_PS\17.dgn
michael.cavanaugh

DOCUMENT NOT CONSIDERED
FINAL UNLESS ALL
SIGNATURES COMPLETED

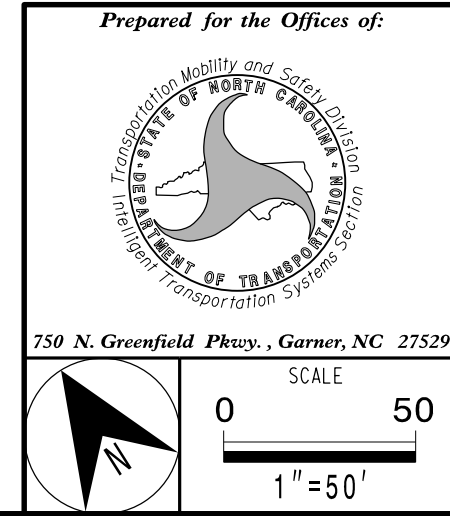

<p>Prepared for the Offices of:  </p>			
<p>Communication Cable and Conduit Routing Plans</p>			
Division 14 Henderson Co.		REVIEWED BY: S. W. Cox	
PLAN DATE: December 2020		REVIEWED BY: F. A. Campbell	
PREPARED BY: M. P. Cavanaugh		REVISIONS	INIT. DATE
<p>DocuSigned by: Frances A. Campbell 12/8/2020 119D84E20887C</p>			

<p>DocuSigned by: Frances A. Campbell 12/8/2020 119D84E20887C</p>
<p>CADD Filename:</p>

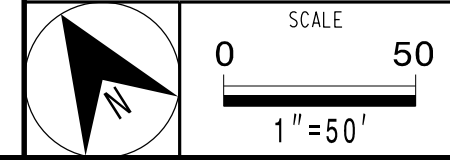

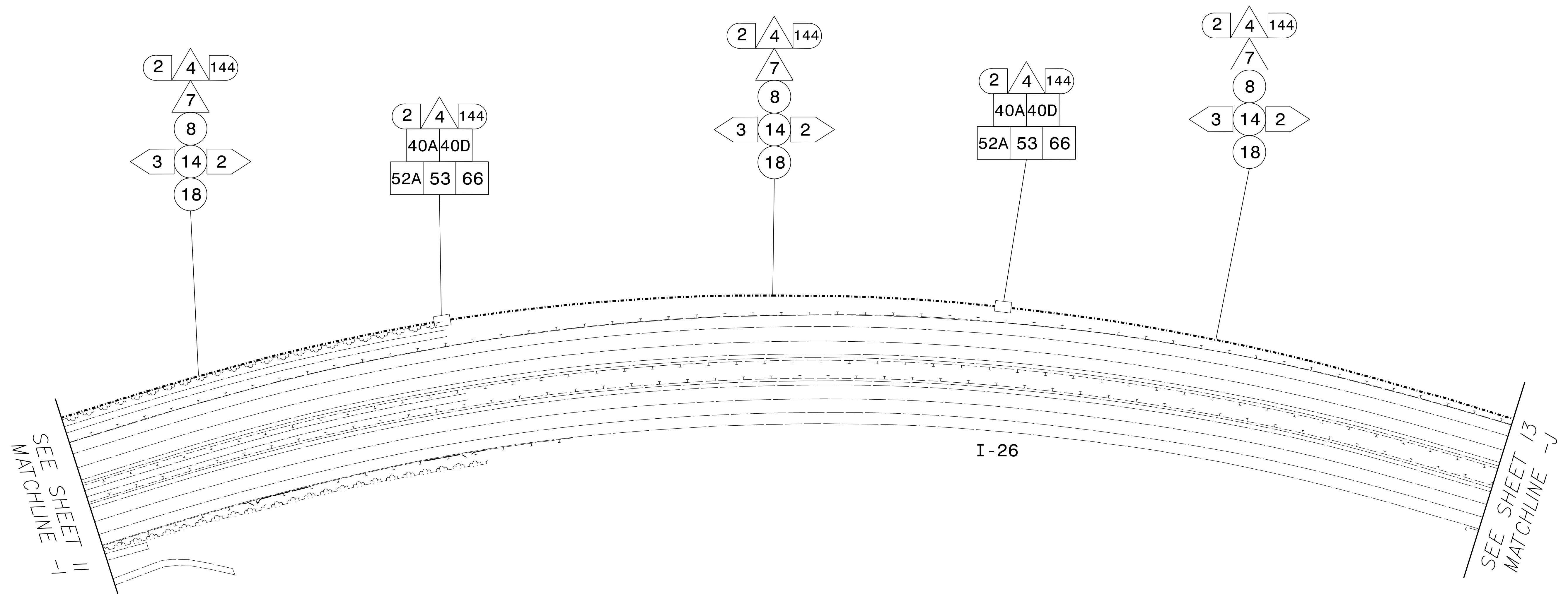

SEE SHEET 11
MATCHLINE

SEE SHEET 13
MATCHLINE - J

I-26

CONDUIT LAYOUT
 BLUE = 144 FO (SPARE)
 ORANGE = 144 FO (ACTIVE)
 GREEN = SPARE
 RED = POWER

- NOTES:**
- USE 144 FIBER IN ORANGE DUCT FOR ALL DEVICES ON THIS PROJECT.

12/17/2020
P:\060887170-126_Greenfield_Phas..._TIP\Traffic\GIS\GIS\001\GIS\001\15BPR.20\15BPR.20_ITS-12.dgn
michael.cavanaugh

DOCUMENT NOT CONSIDERED
FINAL UNLESS ALL
SIGNATURES COMPLETED



Communication Cable and Conduit Routing Plans

Division 14 Henderson Co.

PLAN DATE: December 2020 REVIEWED BY: S. W. Cox
 PREPARED BY: M. P. Cavanaugh REVIEWED BY: F. A. Campbell

REVISIONS	INIT.	DATE

DocuSigned by:
Francis Campbell 12/8/2020
 119D84E208847C
 CADD Filename:

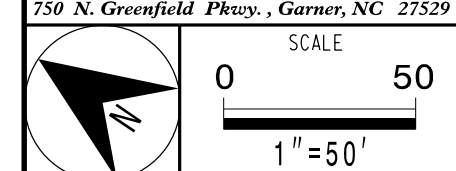

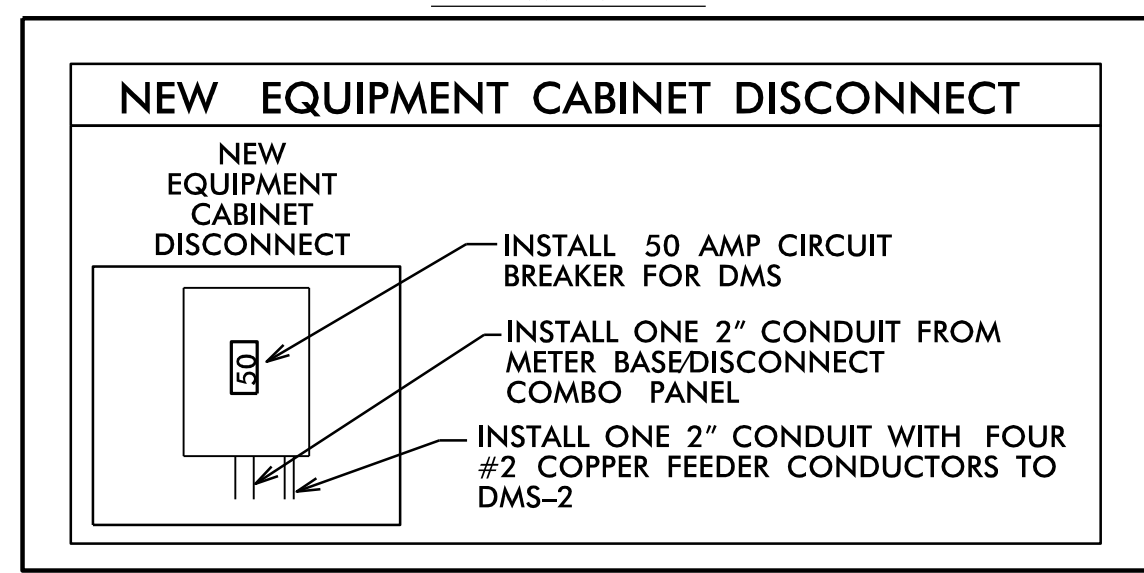
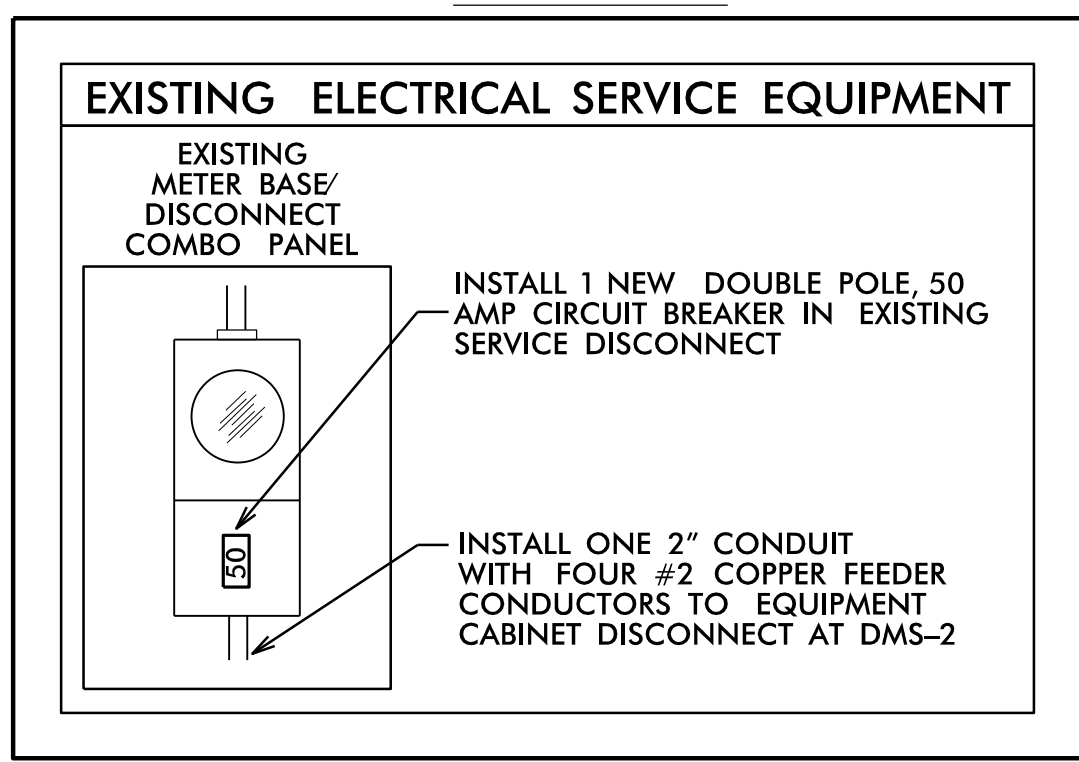
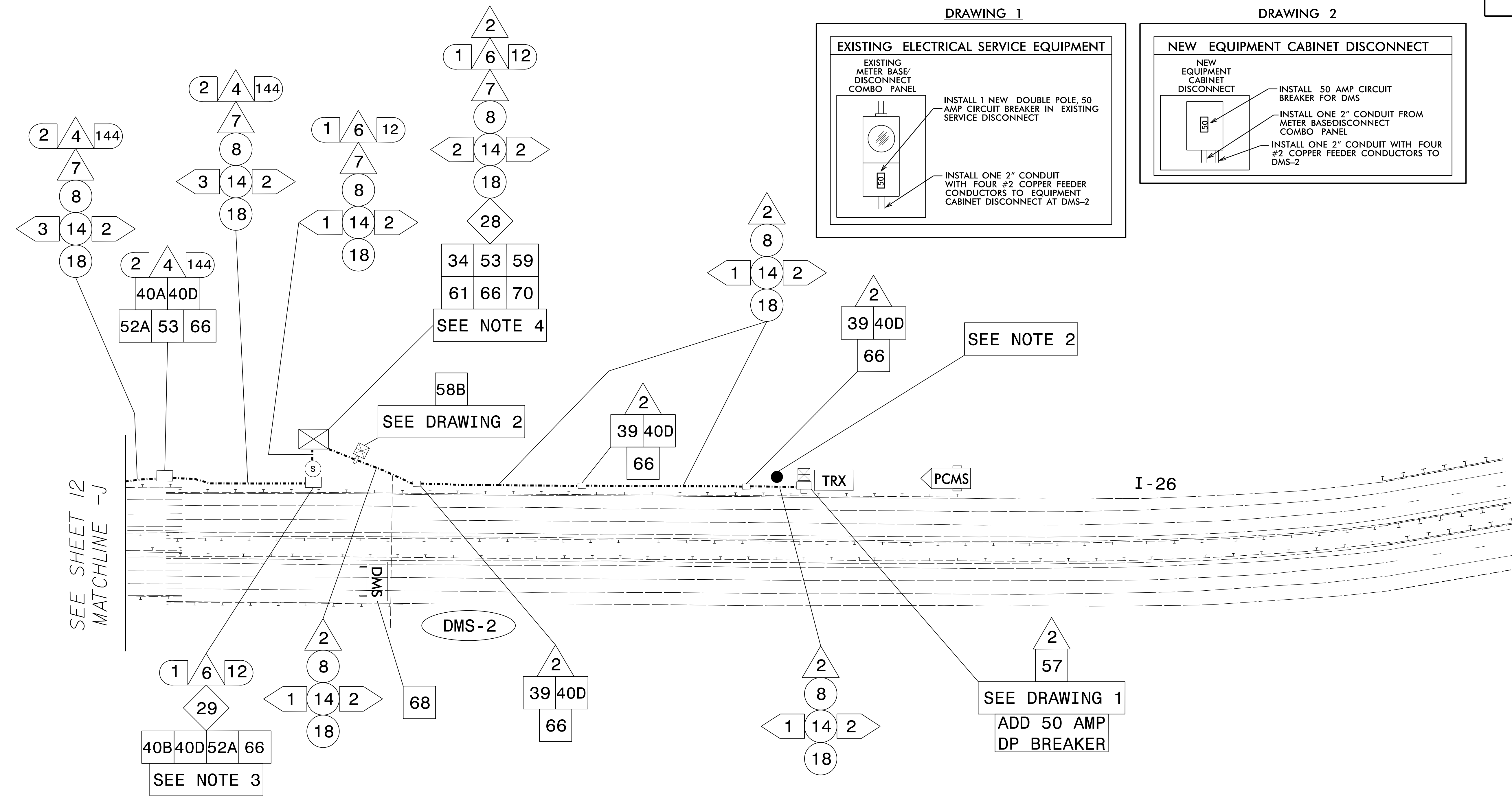

CONDUIT LAYOUT
 BLUE = 144 FO (SPARE)
 ORANGE = 144 FO (ACTIVE)
 GREEN = SPARE
 RED = POWER

- NOTES:**
1. USE 144 FIBER IN ORANGE DUCT FOR ALL DEVICES ON THIS PROJECT.
 2. EXISTING WOOD POLE FOR TRUCK SPEED DETECTION SYSTEM (TO REMAIN).
 3. STORE 50 FEET OF FIBER OPTIC CABLE.
 4. TERMINATE FIBER TO ETHERNET SWITCH, BUT DO NOT CONNECT ETHERNET SWITCH TO THE FIELD DEVICE. CONNECT FIELD DEVICE TO THE CELLULAR MODEM.

12/17/2020 P:\06087170-1-26_GreenRt1-ver-1004900-CAD-01S4910-CAD\W70_NCDOT_11P\Traffic\c&s\cna\lsh\004\lsh\ITS\1-26_ITS_PSH15.dgn michael.cavanaugh

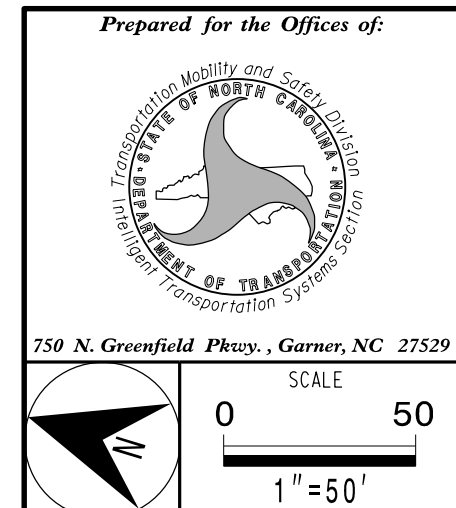

Communication Cable and Conduit Routing Plans

Division 14 Henderson Co.

PLAN DATE: December 2020 REVIEWED BY: S. W. Cox

PREPARED BY: M. P. Cavanaugh REVIEWED BY: F. A. Campbell

REVISIONS	INIT.	DATE

DocuSigned by:
 Frances Campbell 12/8/2020
 119D84E20887C
 CADD Filename:

DOCUMENT NOT CONSIDERED FINAL UNLESS ALL SIGNATURES COMPLETED

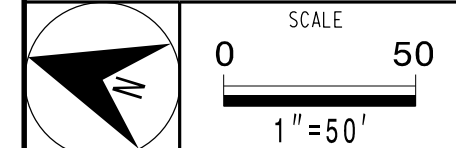

NEW UNDERGROUND SPLICE ENCLOSURE
CCTV-1
I-26 AT US 25 INTERCHANGE
DMS. INV. # 14-___

LEGEND

COLOR CODE TIA/EIA 598-A	
(1) BLUE	(7) RED
(2) ORANGE	(8) BLACK
(3) GREEN	(9) YELLOW
(4) BROWN	(10) VIOLET
(5) SLATE	(11) ROSE
(6) WHITE	(12) AQUA

X = NEW FUSION SPLICE INDIVIDUAL FIBER
C = CAP, COIL, AND SEAL

Notes:
Unused fibers left coiled and stored in splice tray.
Unused Buffer Tubes left coiled and stored in splice tray.

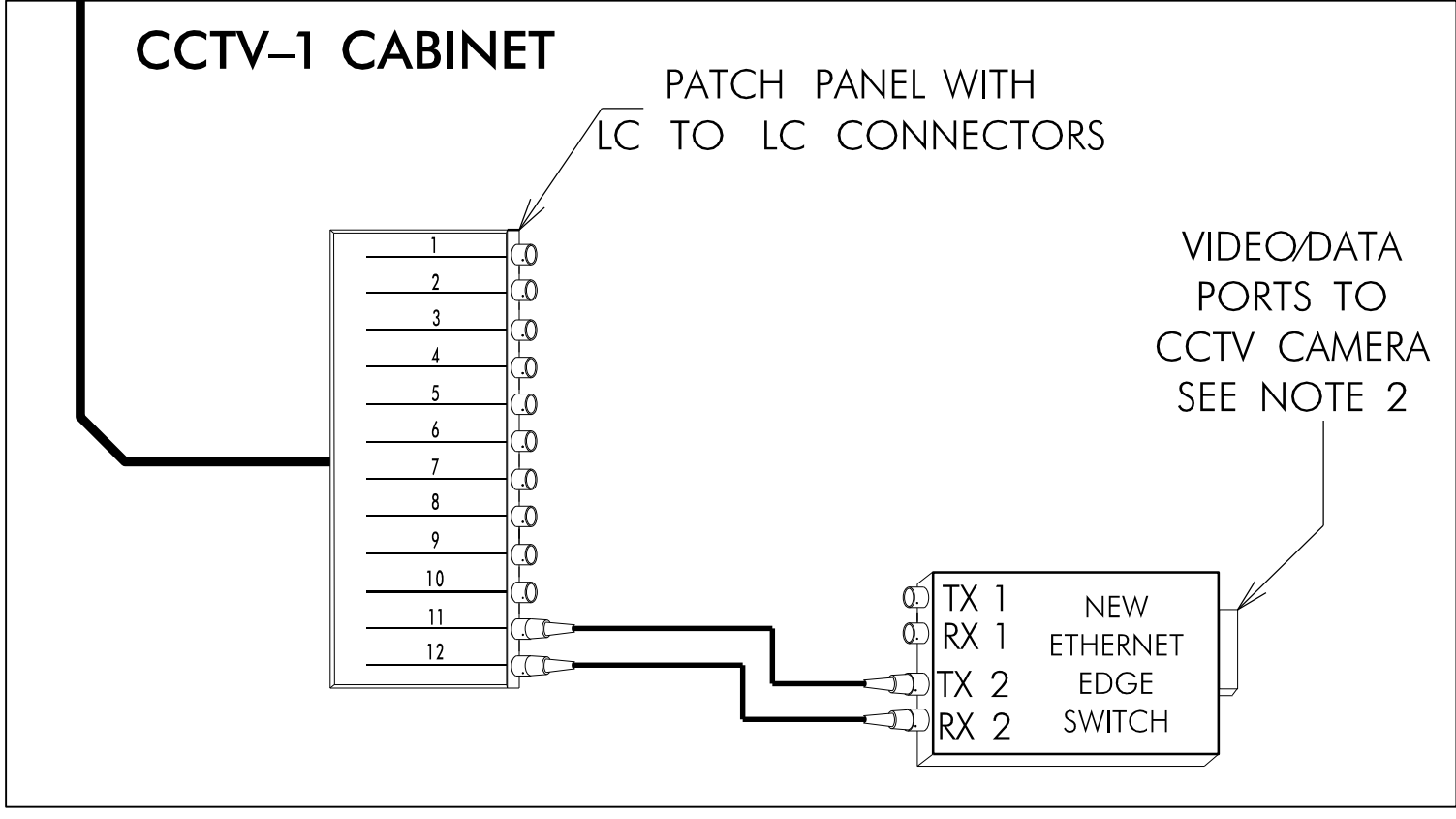
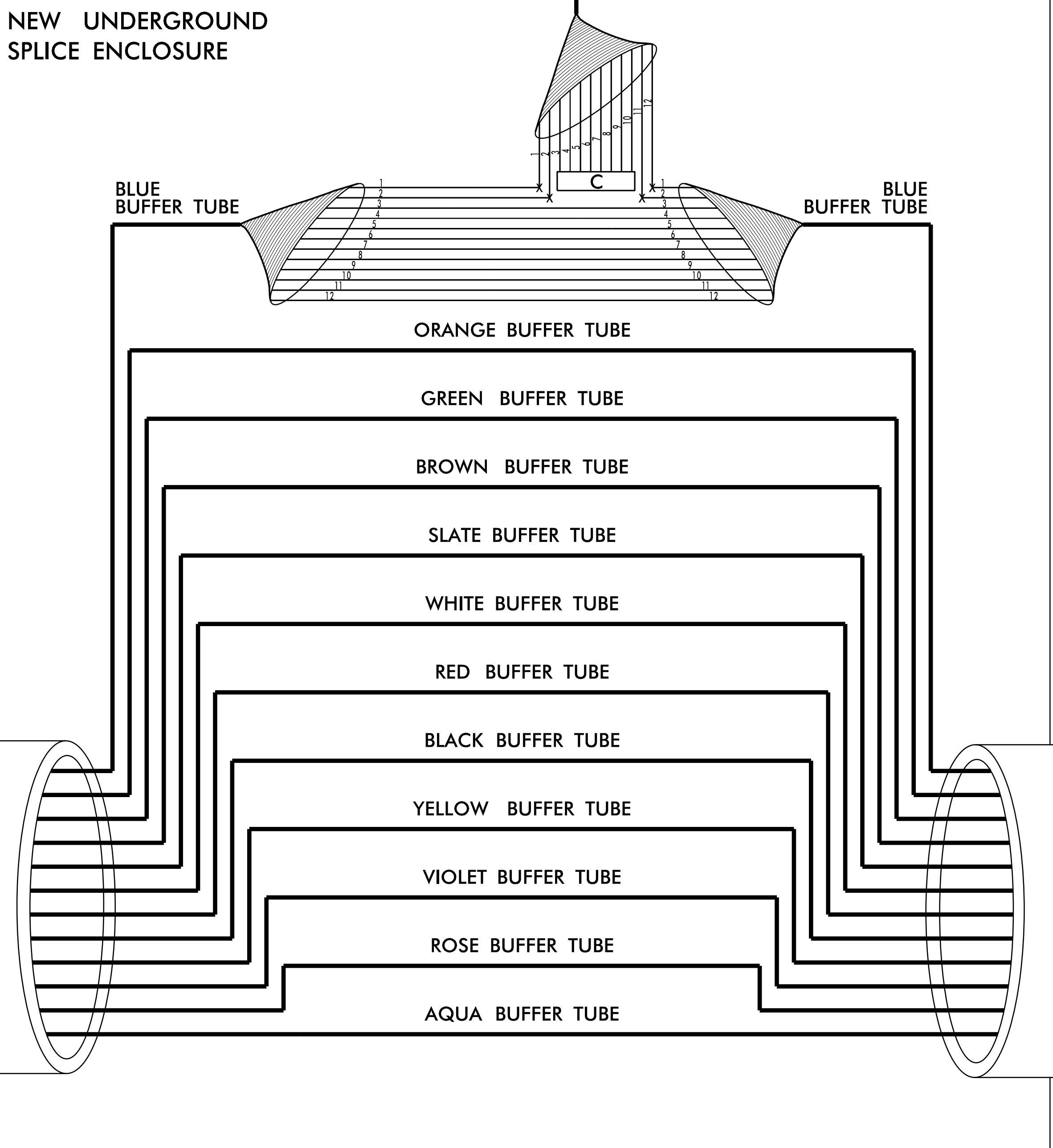

NEW CABLE
TO
US 25 INTERCHANGE

NEW CABLE
TO
DMS-1
NEAR MM 55

144 FIBERS IN 12 BUFFER TUBES

144 FIBERS IN 12 BUFFER TUBES

INCLUDE ON THE COVER OF EACH SPLICE TRAY THE FOLLOWING:
REFERENCE SECTION 1731 "FIBER OPTIC SPLICE ENCLOSURE"

1) SPLICE LOCATION
2) DATE
3) COMPANY NAME
4) NAME OF INDIVIDUAL PERFORMING THE SPLICING

PRIOR TO INSTALLING THE COVER ON THE SPLICE TRAY TAKE A DIGITAL PHOTOGRAPH SHOWING THE SPLICE TRAY AND INFORMATION SHOWN ABOVE (1-4) AND SUBMIT PHOTOGRAPH ALONG WITH OTDR TEST RESULTS.

- NOTES:**
- ETHERNET SWITCH TERMINATION CONFIGURATIONS ARE GENERIC. THE CONTRACTOR IS RESPONSIBLE FOR DETERMINING /ENSURING PROPER TERMINATIONS.
 - TERMINATE FIBER TO ETHERNET SWITCH, BUT DO NOT CONNECT ETHERNET SWITCH TO THE FIELD DEVICE. CONNECT FIELD DEVICE TO CELLULAR MODEM.

DOCUMENT NOT CONSIDERED FINAL UNLESS ALL SIGNATURES COMPLETED

Prepared for the Offices of:
STATE OF NORTH CAROLINA
DEPARTMENT OF TRANSPORTATION

**Fiber Optic Splice Detail
Splice Enclosure CCTV-1
(14-___)**

Division 14 Henderson Co.
PLAN DATE: December 2020 REVIEWED BY: F. A. Campbell
PREPARED BY: S. W. COX REVIEWED BY:

REVISIONS	INIT.	DATE

SCALE
0 NA
N.T.S.

Seal: NORTH CAROLINA PROFESSIONAL SEAL 041673
ENGINEER
FRANCE A. CAMPBELL

DocuSigned by:
France Campbell 12/8/2020
119D94E20887C
CADD File name:

AECOM
NC Firm License No.: F-0342
701 Corporate Center Drive
Suite 475 Raleigh, NC 27607
Phone: 919-854-6200

NEW UNDERGROUND SPLICE ENCLOSURE
EB DMS-1
I-26 NEAR MM 55.0
DMS. INV. # 14-___

LEGEND

COLOR CODE TIA/EIA 598-A		X = NEW FUSION SPLICE INDIVIDUAL FIBER
		C = CAP, COIL, AND SEAL
(1) BLUE	(7) RED	
(2) ORANGE	(8) BLACK	
(3) GREEN	(9) YELLOW	
(4) BROWN	(10) VIOLET	
(5) SLATE	(11) ROSE	
(6) WHITE	(12) AQUA	

Notes:
Unused fibers left coiled and stored in splice tray.
Unused Buffer Tubes left coiled and stored in splice tray.

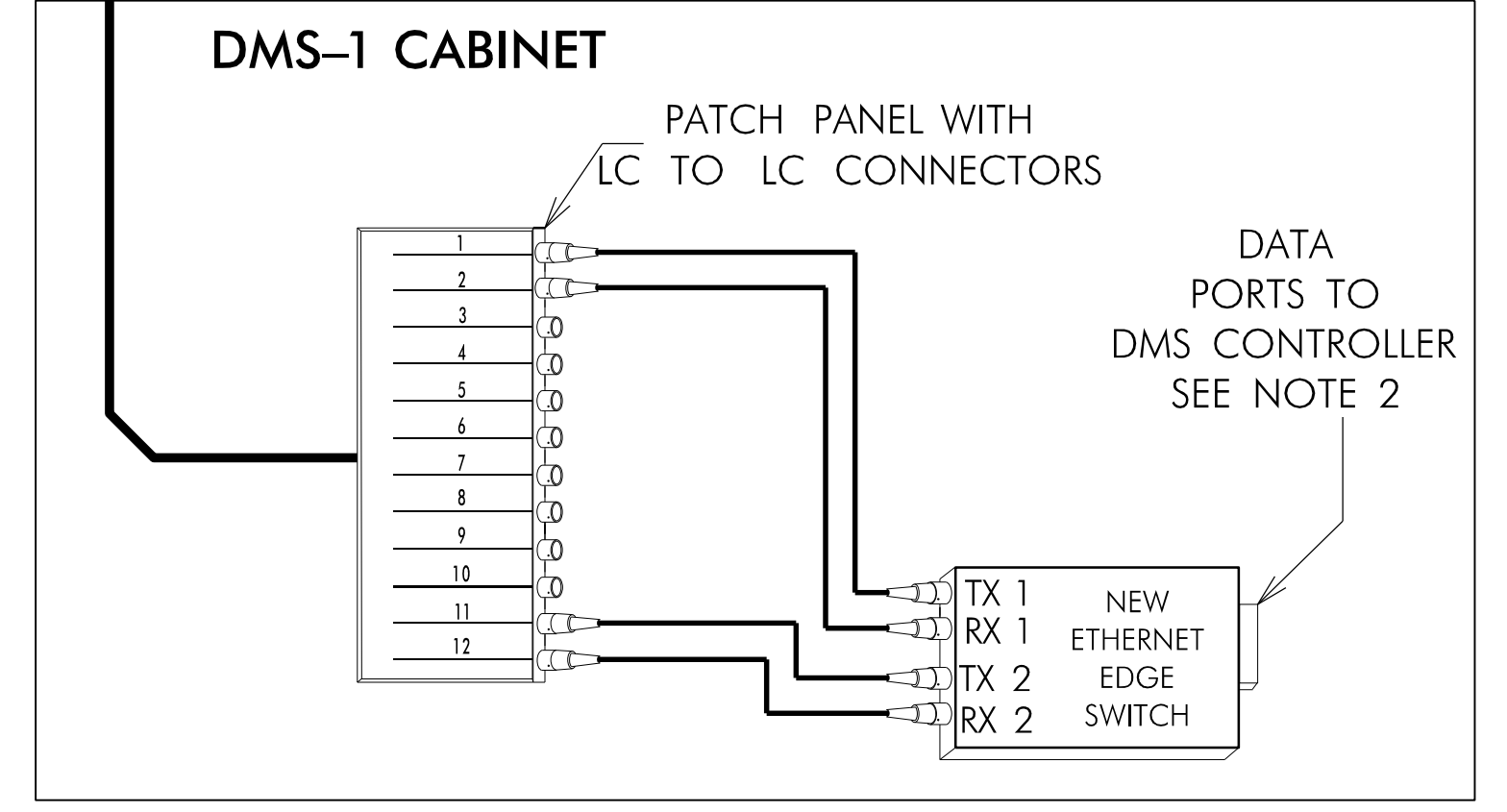
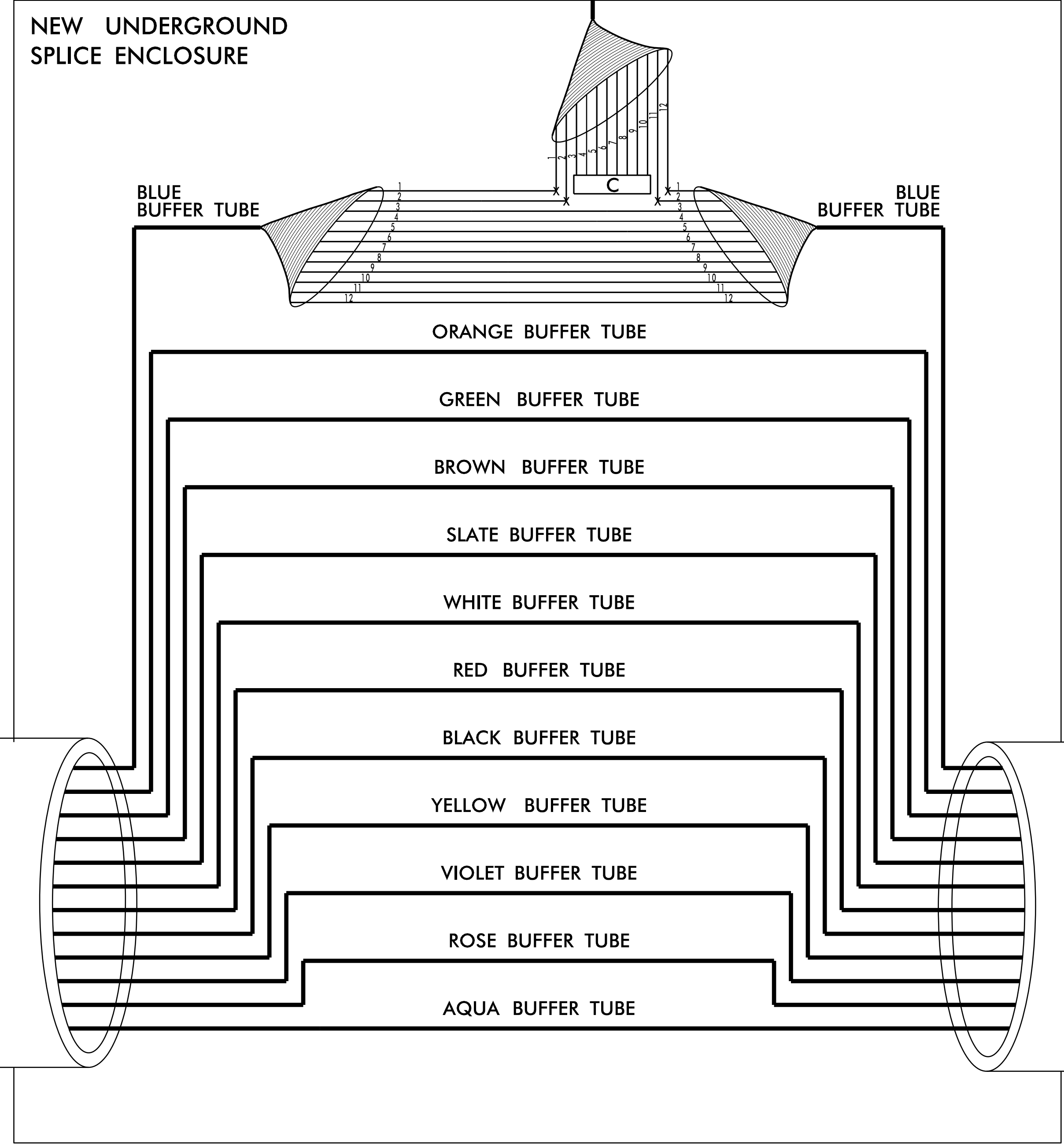

NEW CABLE TO
CCTV-1
US 25 INTERCHANGE

NEW CABLE TO
CCTV-2
NEAR MM 55.5

144 FIBERS IN 12 BUFFER TUBES

144 FIBERS IN 12 BUFFER TUBES

INCLUDE ON THE COVER OF EACH SPLICE TRAY THE FOLLOWING:
REFERENCE SECTION 1731 "FIBER OPTIC SPLICE ENCLOSURE"

- 1) SPLICE LOCATION
- 2) DATE
- 3) COMPANY NAME
- 4) NAME OF INDIVIDUAL PERFORMING THE SPLICING

PRIOR TO INSTALLING THE COVER ON THE SPLICE TRAY TAKE A DIGITAL PHOTOGRAPH SHOWING THE SPLICE TRAY AND INFORMATION SHOWN ABOVE (1-4) AND SUBMIT PHOTOGRAPH ALONG WITH OTDR TEST RESULTS.

NOTES:

1. ETHERNET SWITCH TERMINATION CONFIGURATIONS ARE GENERIC. THE CONTRACTOR IS RESPONSIBLE FOR DETERMINING /ENSURING PROPER TERMINATIONS.
2. TERMINATE FIBER TO ETHERNET SWITCH, BUT DO NOT CONNECT ETHERNET SWITCH TO THE FIELD DEVICE. CONNECT FIELD DEVICE TO CELLULAR MODEM.

DOCUMENT NOT CONSIDERED FINAL UNLESS ALL SIGNATURES COMPLETED

Prepared for the Offices of:

**Fiber Optic Splice Detail
Splice Enclosure EB DMS-1
(14-___)**

Division 14 Henderson Co.
 PLAN DATE: December 2020 REVIEWED BY: F. A. Campbell
 PREPARED BY: S. W. COX REVIEWED BY:

REVISIONS	INIT.	DATE

SCALE: 0 NA N.T.S.

DocuSigned by:
France Campbell 12/8/2020
119D84E208847C
CADD File name:

AECOM
 NC Firm License No.: F-0342
 701 Corporate Center Drive
 Suite 475 Raleigh, NC 27607
 Phone: 919-854-6200

12/7/2020 P:\06087170-1-26_Greenfield ver_1004900_CAD_01S4910_CAD\170_NCDOT_11P\170\off\caks\caks\splices\splices\splices\14-26_ITS_PSH18.dgn micheal.l.covey@hughes.net

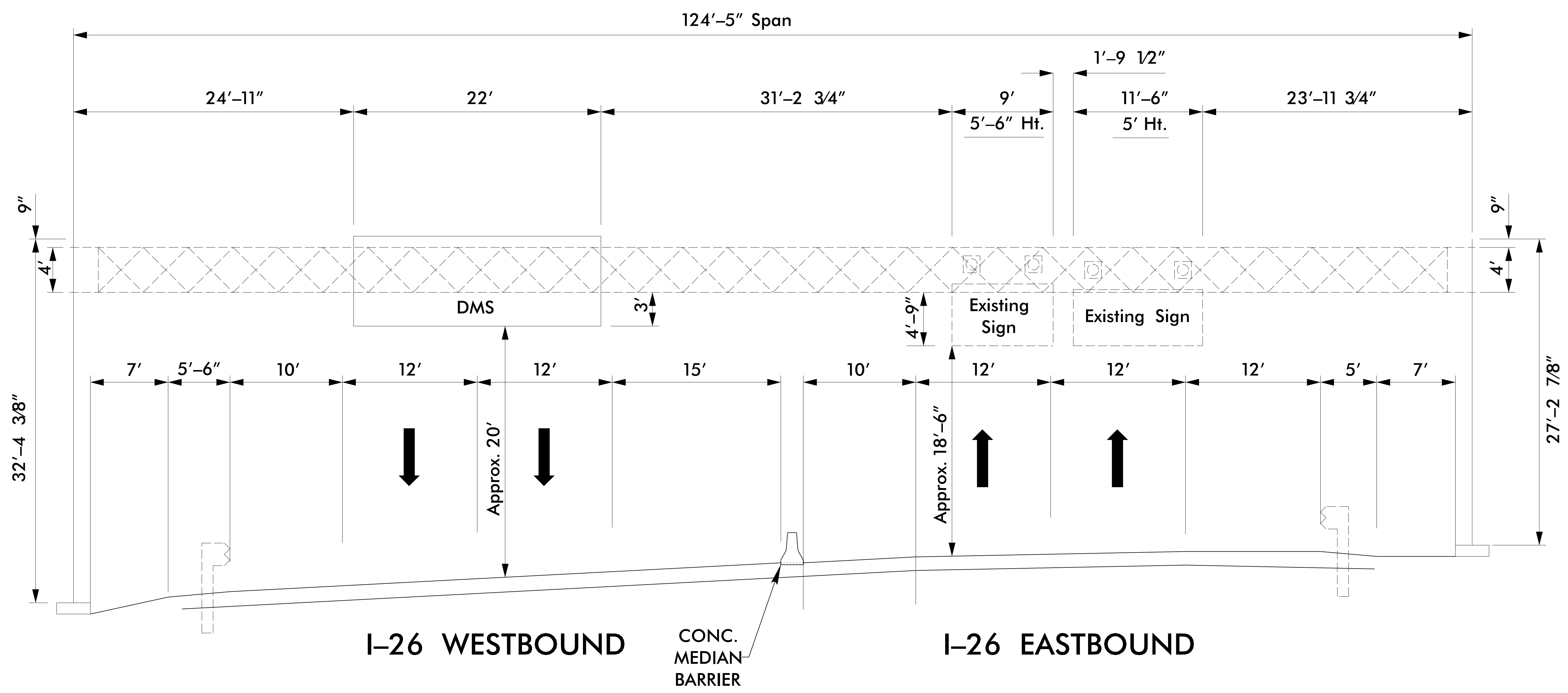

+/- 545' East From Milemarker 55

12/7/2020 P:\060887170-126_Greenfield\126_Greenfield_CAD\126_Greenfield_CAD.dwg (126)_ITS.dwg
michael.cavanaugh



Prepared for the Offices of:
Division 14 Henderson Co.

Elevation View
DMS-1
I-26 WB

PLAN DATE: December 2020
PREPARED BY: M. P. Cavanaugh
REVIEWED BY: S. W. Cox

750 N. Greenfield Pkwy., Garner, NC 27529
SCALE: 1" = 5'

REVISIONS	INIT.	DATE

DOCUMENT NOT CONSIDERED FINAL UNLESS ALL SIGNATURES COMPLETED

Seal of a North Carolina Professional Engineer, No. 041673, signed by Frances A. Campbell.

DocuSigned by:
Frances Campbell 12/8/2020
119D84E20887C
CADD Filename:

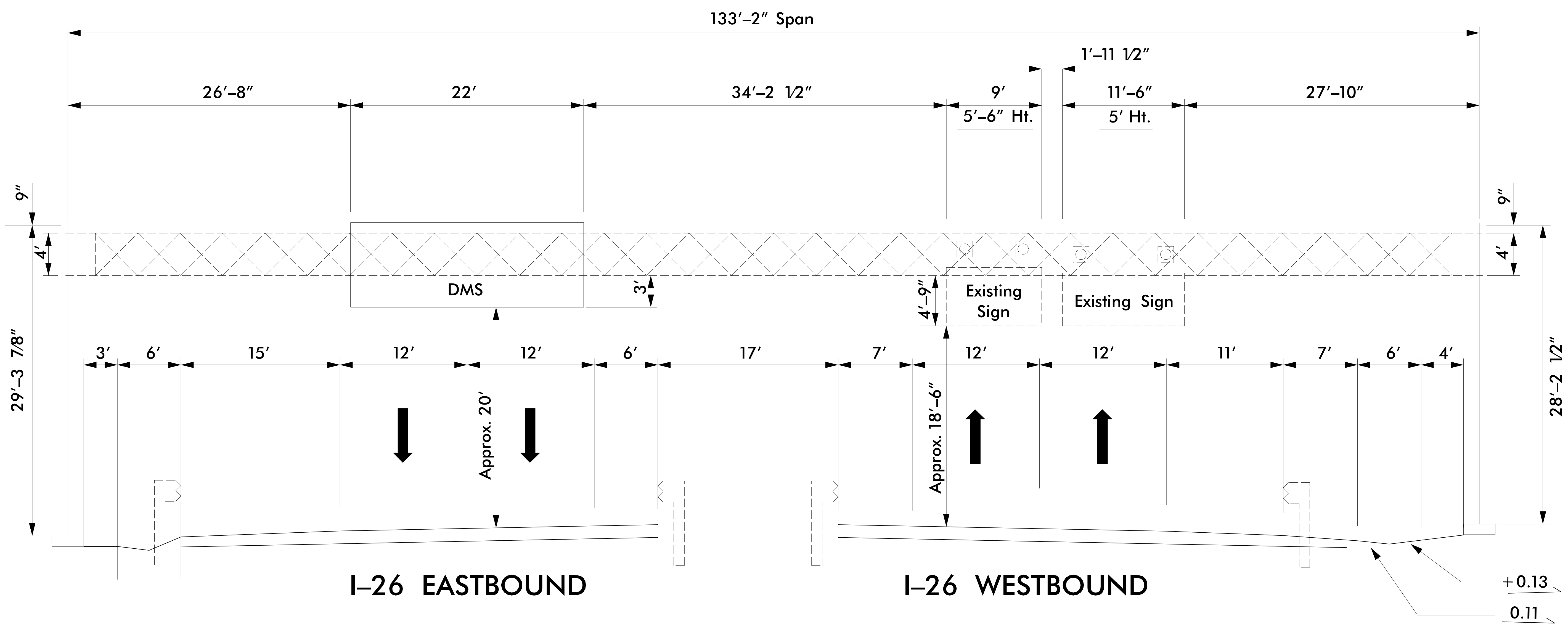

I-26 EASTBOUND

I-26 WESTBOUND

+/- 2045' East From Milemarker 56

12/7/2020 P:\060887170-1-26_Greenfield_CAD_0154910_CAD\170_NCDOT_TIP\Traffic\060887170-1-26_ITS_P5125.dgn michael.cavanaugh



Prepared for the Offices of:

Elevation View
DMS-2
I-26 EB
 Division 14 Henderson Co.

PLAN DATE: December 2020 REVIEWED BY: S. W. Cox
 PREPARED BY: M. P. Cavanaugh REVIEWED BY: F. A. Campbell

REVISIONS	INIT.	DATE

SCALE: 1" = 5'

DOCUMENT NOT CONSIDERED FINAL UNLESS ALL SIGNATURES COMPLETED

DocuSigned by:
Frances Campbell 12/8/2020
 119D84E208847C
 CADD Filename:

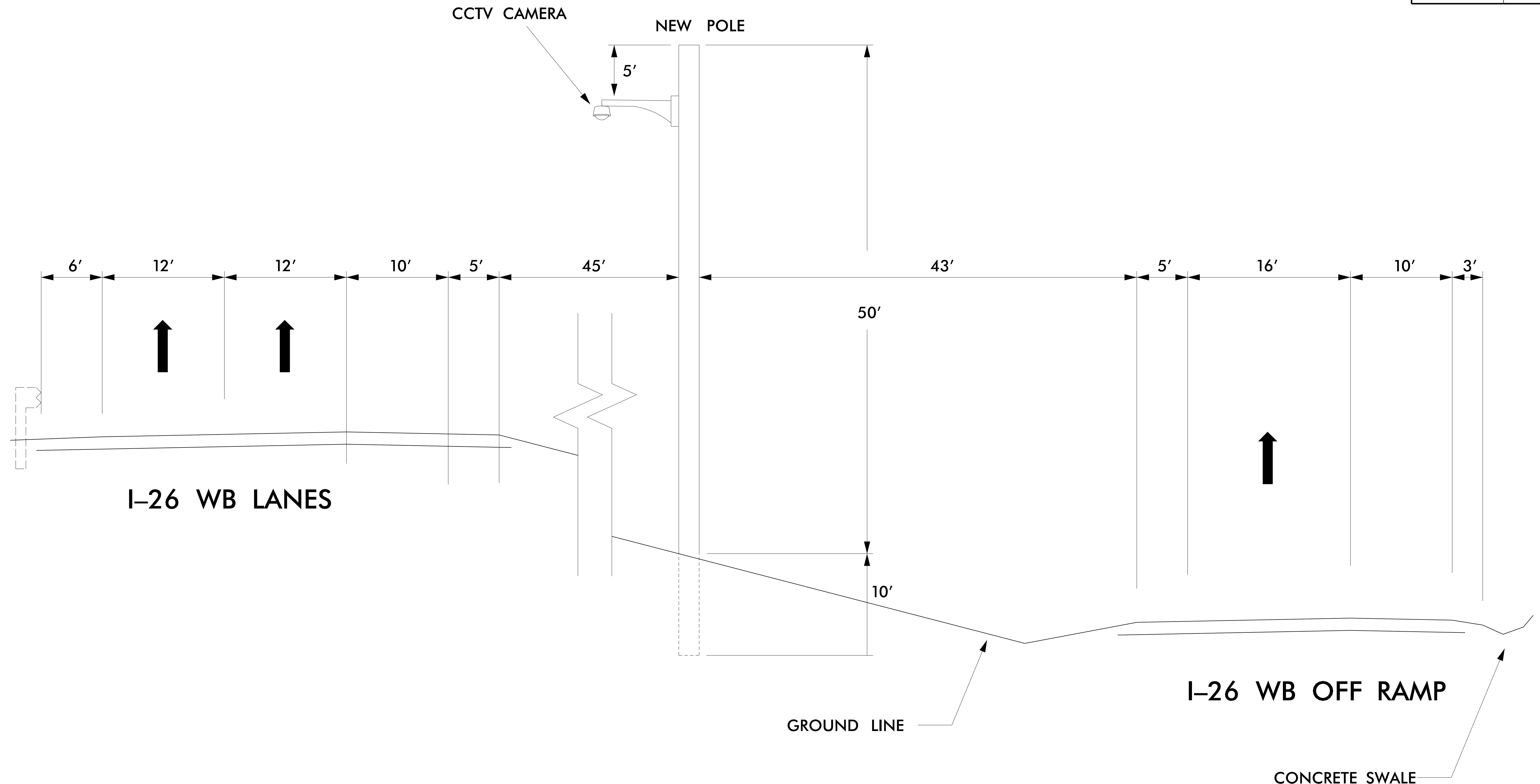

I-26 WB LANES

NEW POLE

CCTV CAMERA

I-26 WB OFF RAMP

GROUND LINE

CONCRETE SWALE

+/- 1900' East From Milemarker 59

12/7/2020 P:\60587170-1-26_Greenfield_Pkwy-700-4900-CAD-0154910-CAD\70_NCDOT_TIP\Traffic\05\05a\05a.dwg I:\S\1-26_ITS_P5124.dwg michael.cavanaugh

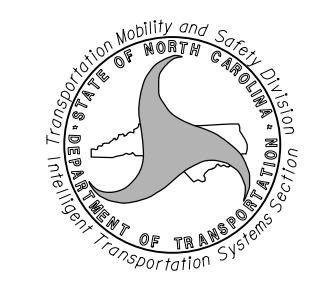
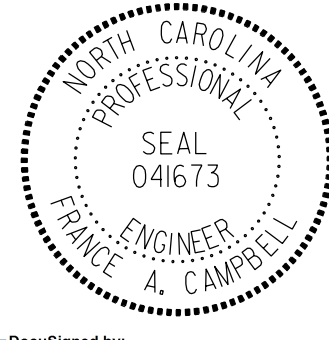

Prepared for the Offices of:		DOCUMENT NOT CONSIDERED FINAL UNLESS ALL SIGNATURES COMPLETED	
 Elevation View CCTV-3 I-26 WB Division 14 Polk Co.			
PLAN DATE: December 2020	REVIEWED BY: S. W. Cox	Prepared by: M. P. Cavanaugh Reviewed by: F. A. Campbell	
750 N. Greenfield Pkwy., Garner, NC 27529	SCALE: 1" = 5'	REVISIONS	INIT. DATE
0 5 1" = 5'			
DocuSigned by: Francis Campbell 12/8/2020 119D84E208847C		CADD Filename:	

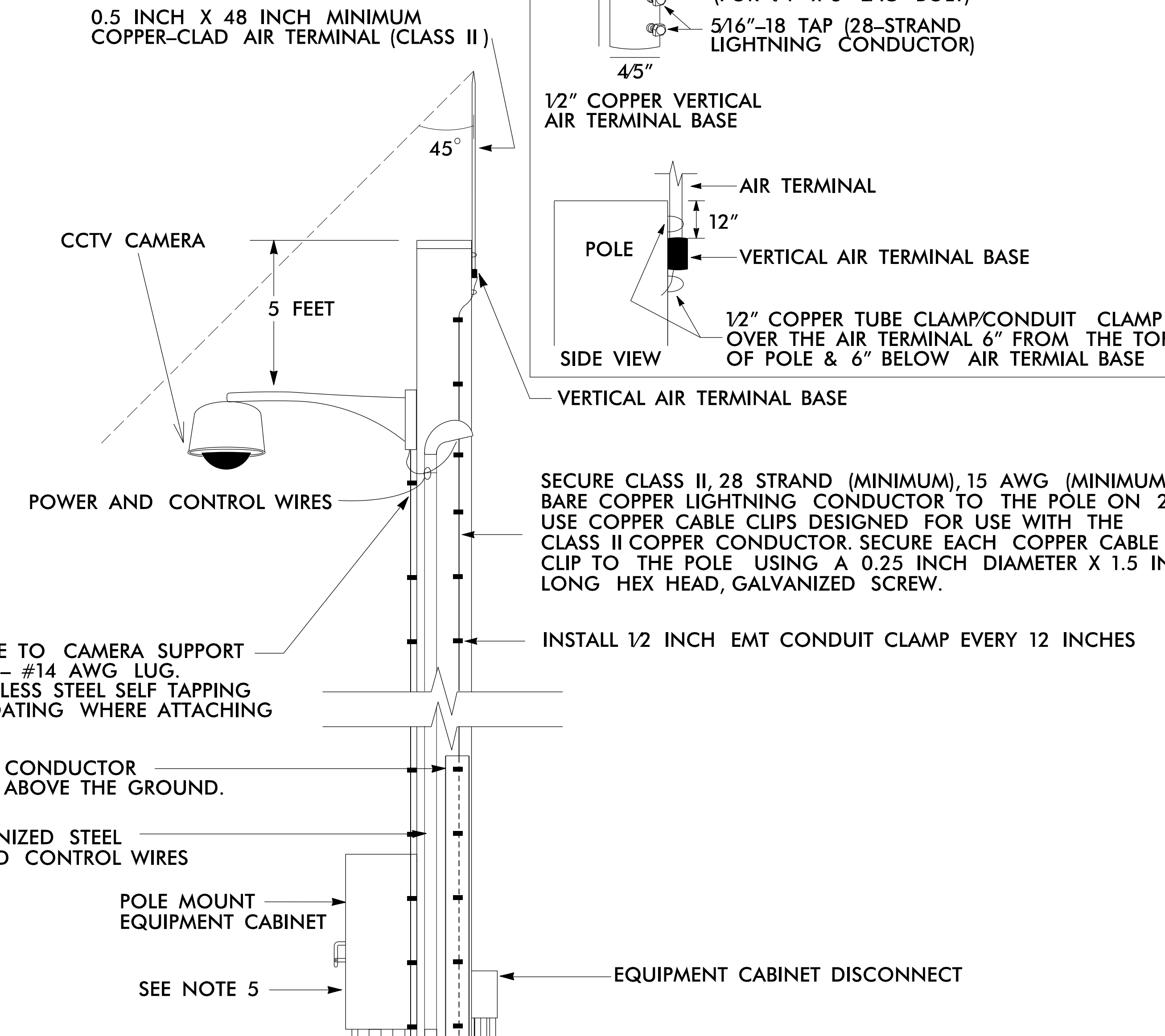
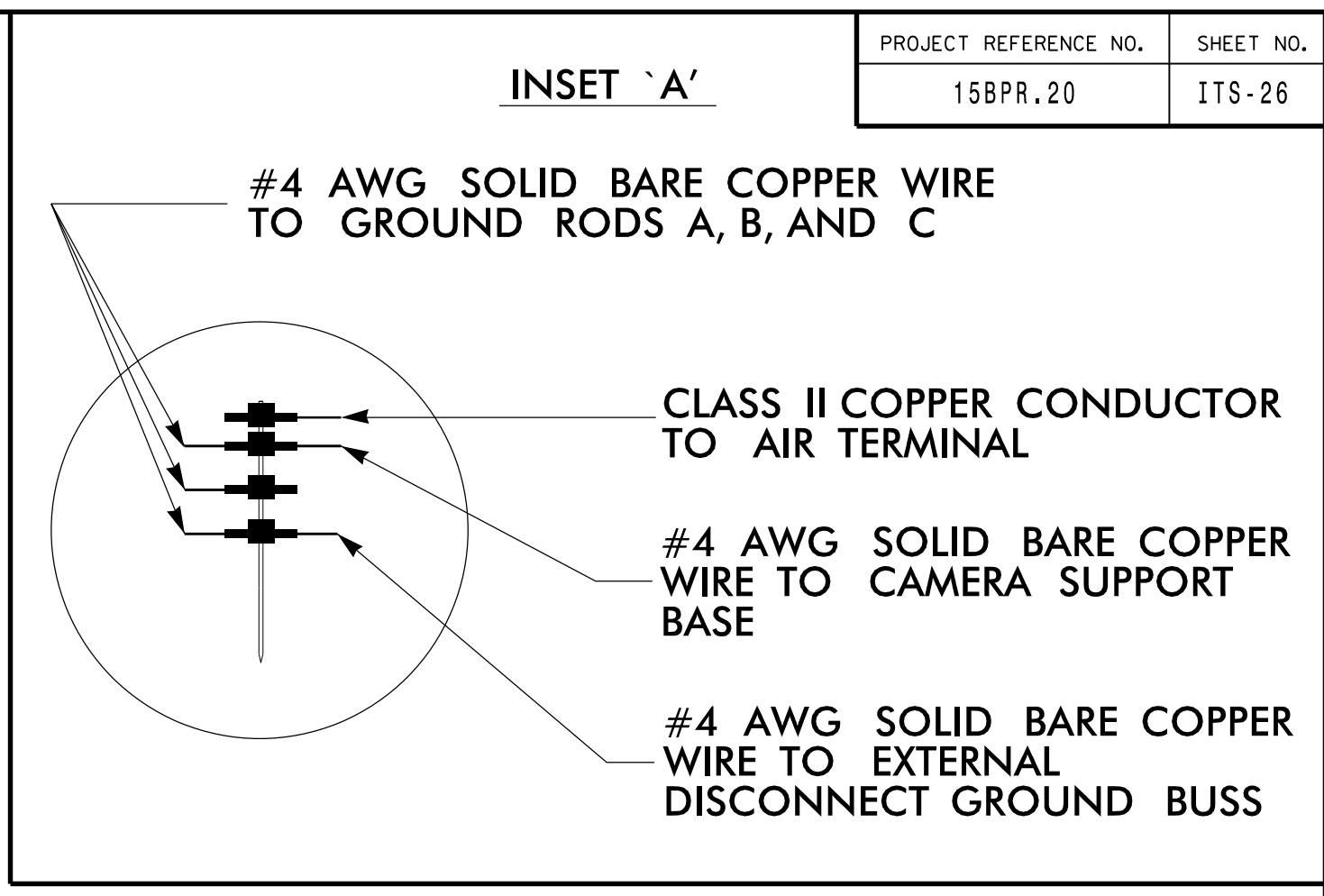
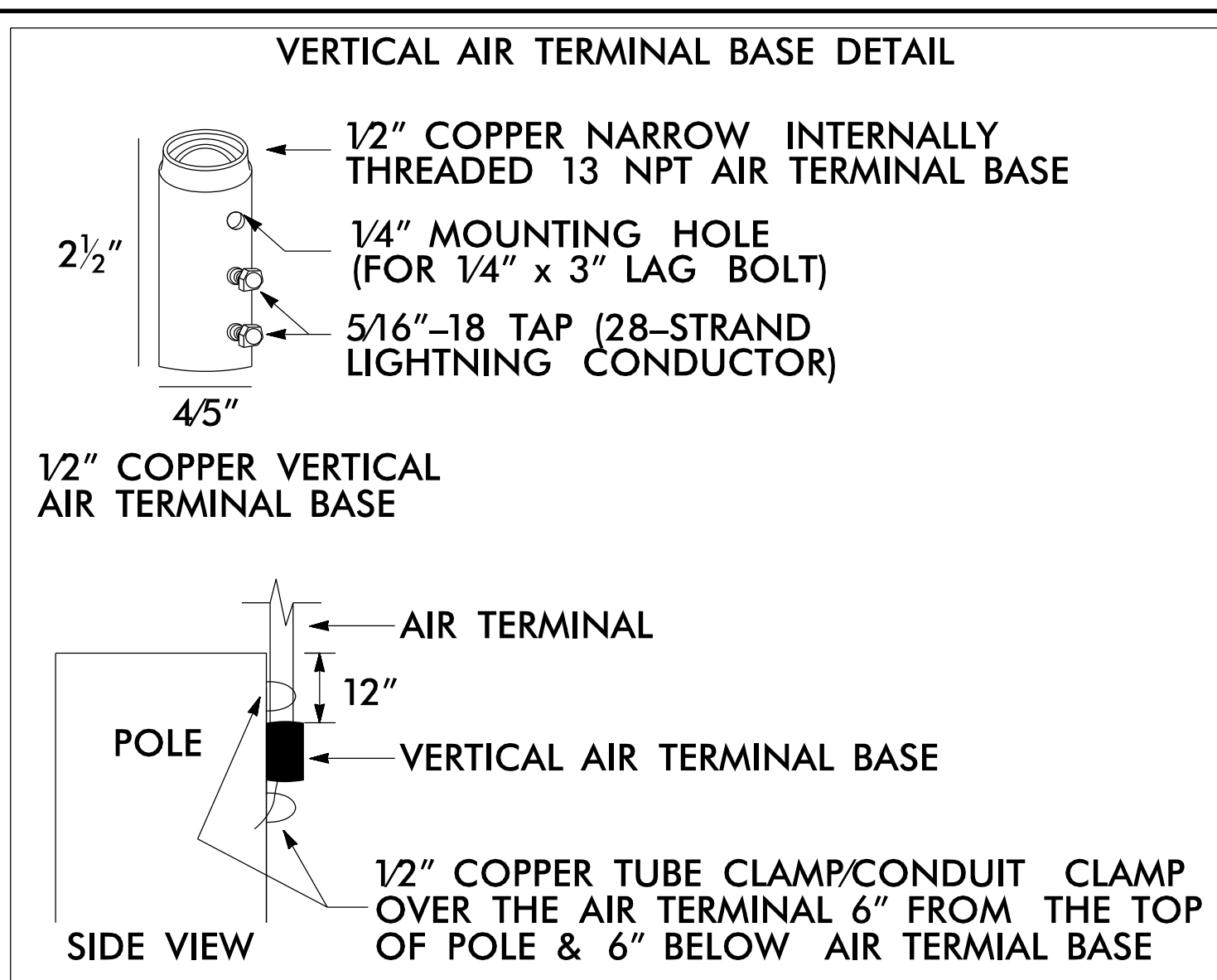
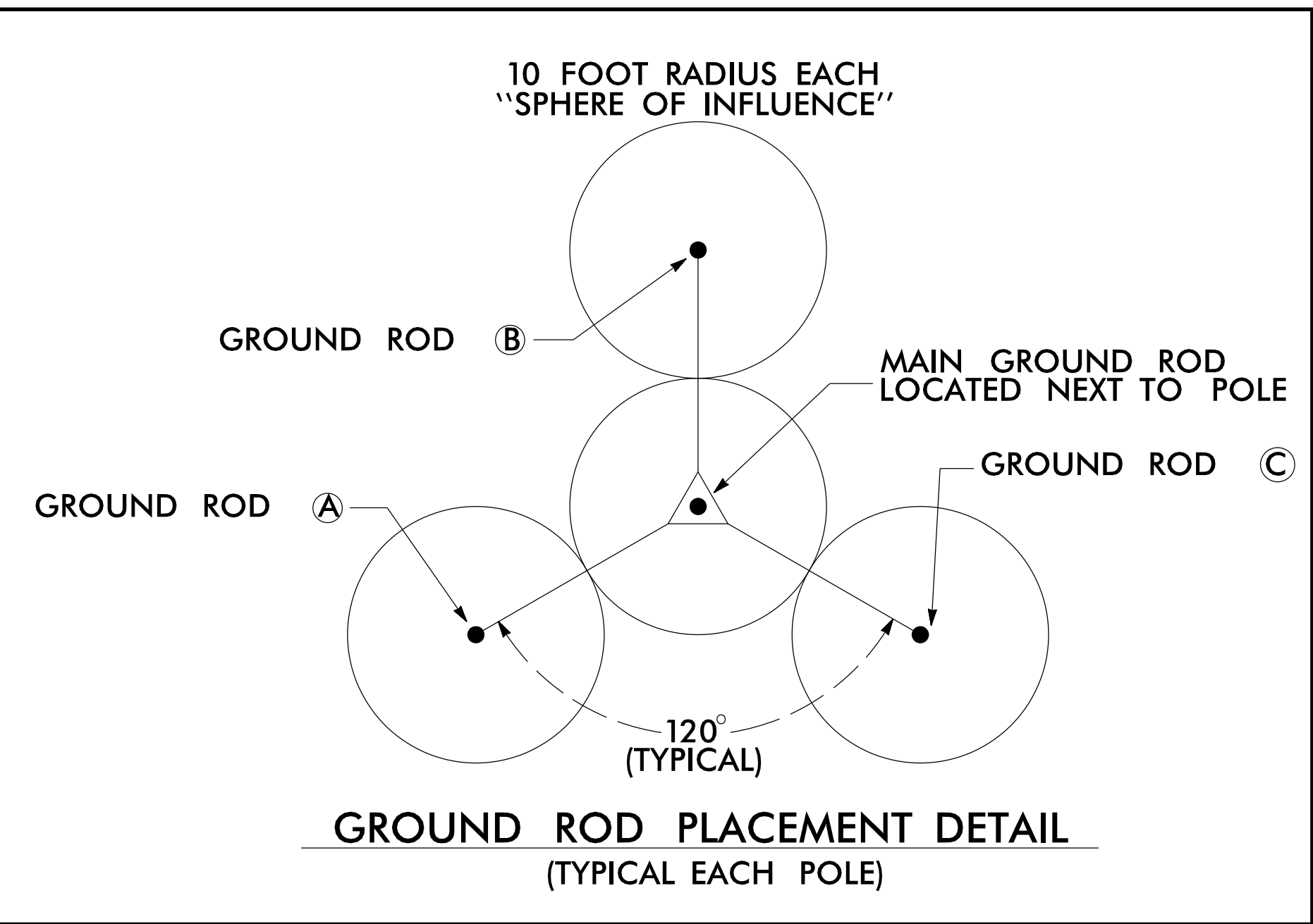

BOND #4 AWG SOLID BARE COPPER WIRE TO CAMERA SUPPORT BASE BY AN ALUMINUM TO COPPER #2 - #14 AWG LUG. ATTACH TO CAMERA BASE WITH A STAINLESS STEEL SELF TAPPING SCREW. REMOVE PAINT OR PROTECTIVE COATING WHERE ATTACHING LUG ONLY.

INSTALL 2-INCH PVC U-GUARD OVER COPPER CONDUCTOR FROM GROUND LEVEL TO 10 FEET (MINIMUM) ABOVE THE GROUND.

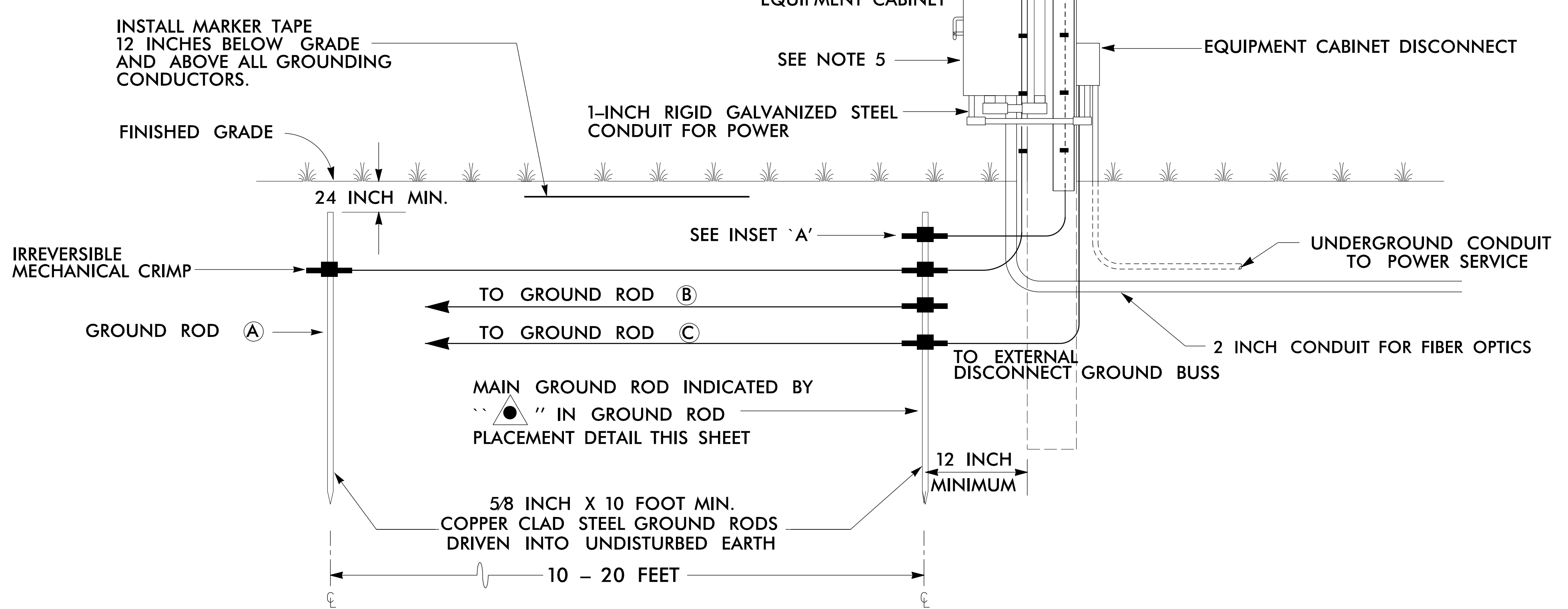
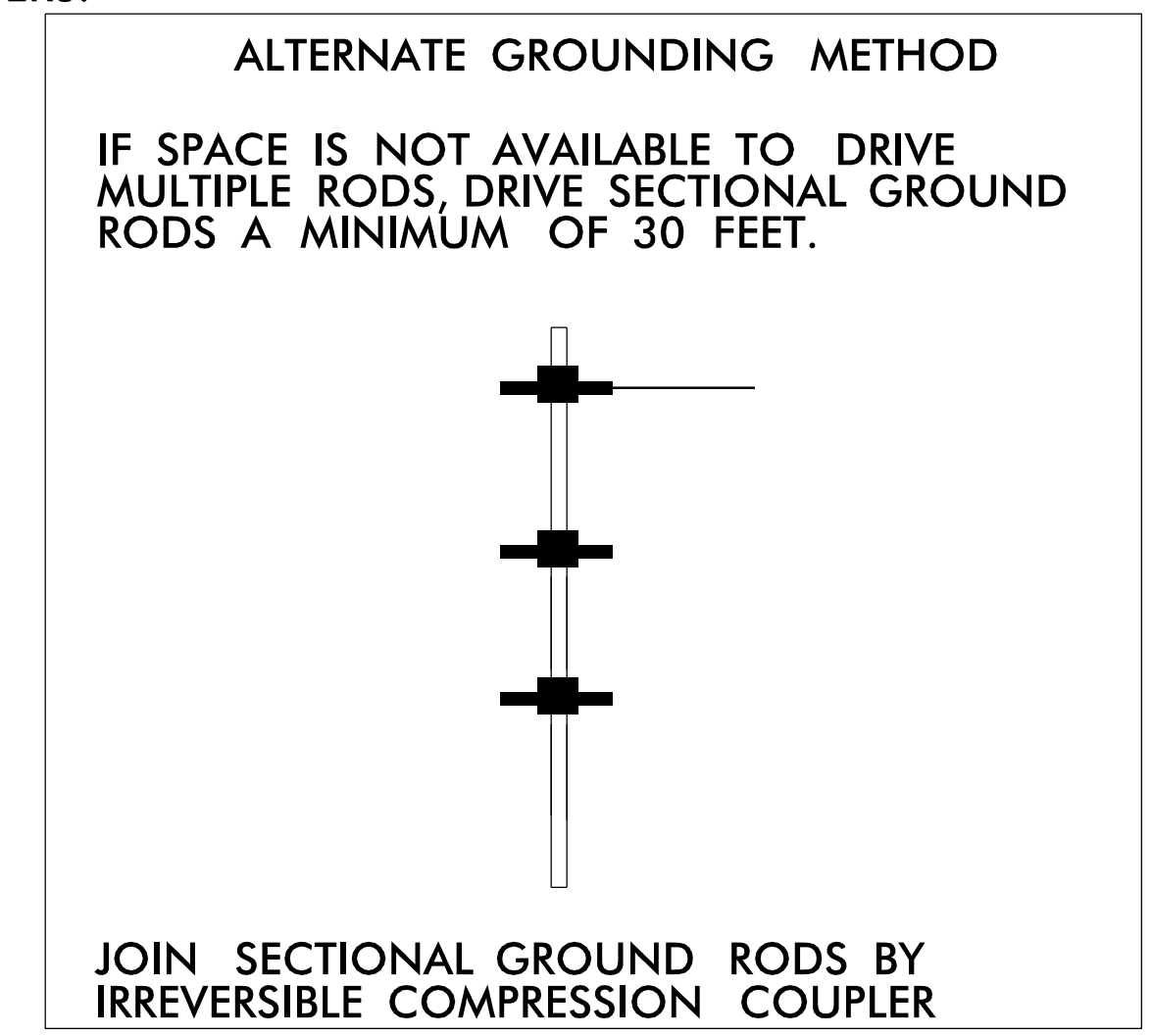

NOTES

1. BOND CLASS II, 28 STRAND (MINIMUM), 15 AWG (MINIMUM) ROPE-LAY BARE COPPER CONDUCTOR TO THE MAIN GROUND ROD BY AN IRREVERSIBLE MECHANICAL CRIMP. MAINTAIN MAXIMUM HORIZONTAL SEPARATION BETWEEN COPPER CONDUCTOR AND RISER.
2. ALL CONNECTIONS TO GROUND RODS SHOULD BE MADE WITH AN IRREVERSIBLE MECHANICAL CRIMP METHOD.
3. REFER TO STANDARD DRAWING 1700-2 FOR ALTERNATE GROUND ROD INSTALLATION METHOD AS APPROVED BY THE ENGINEER.
4. INSTALL MARKER TAPE DIRECTLY ABOVE ALL GROUNDING ELECTRODES AND CONDUCTORS AT A DEPTH OF 12 INCHES.
5. REMOVE BONDING JUMPER BETWEEN EQUIPMENT CABINET GROUND BUSS AND NEUTRAL BUSS.

	CCTV CAMERA INSTALLATION FOR WOOD POLES WITH UNDERGROUND ELECTRICAL SERVICE TYPICAL DETAIL	
	PLAN DATE: December 2020 PREPARED BY: S. W. Cox	REVIEWED BY: F. A. Campbell REVIEWED BY:
750 N. Greenfield Pkwy., Garner, NC 27529 NTS	REVISIONS _____ _____ _____	INIT. DATE _____ _____ _____

DocuSigned by:
France Campbell 12/8/2020
CADD Filename:

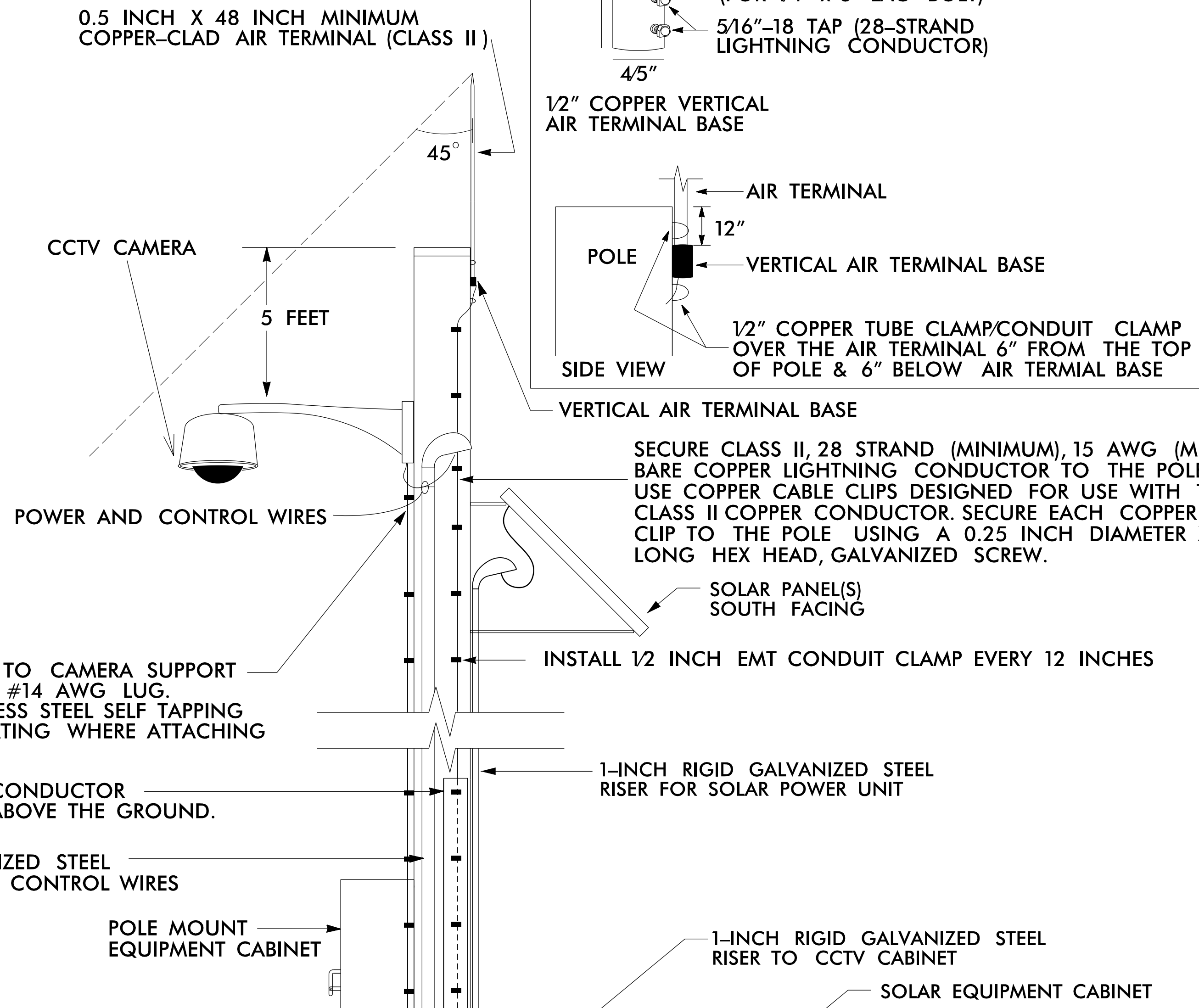
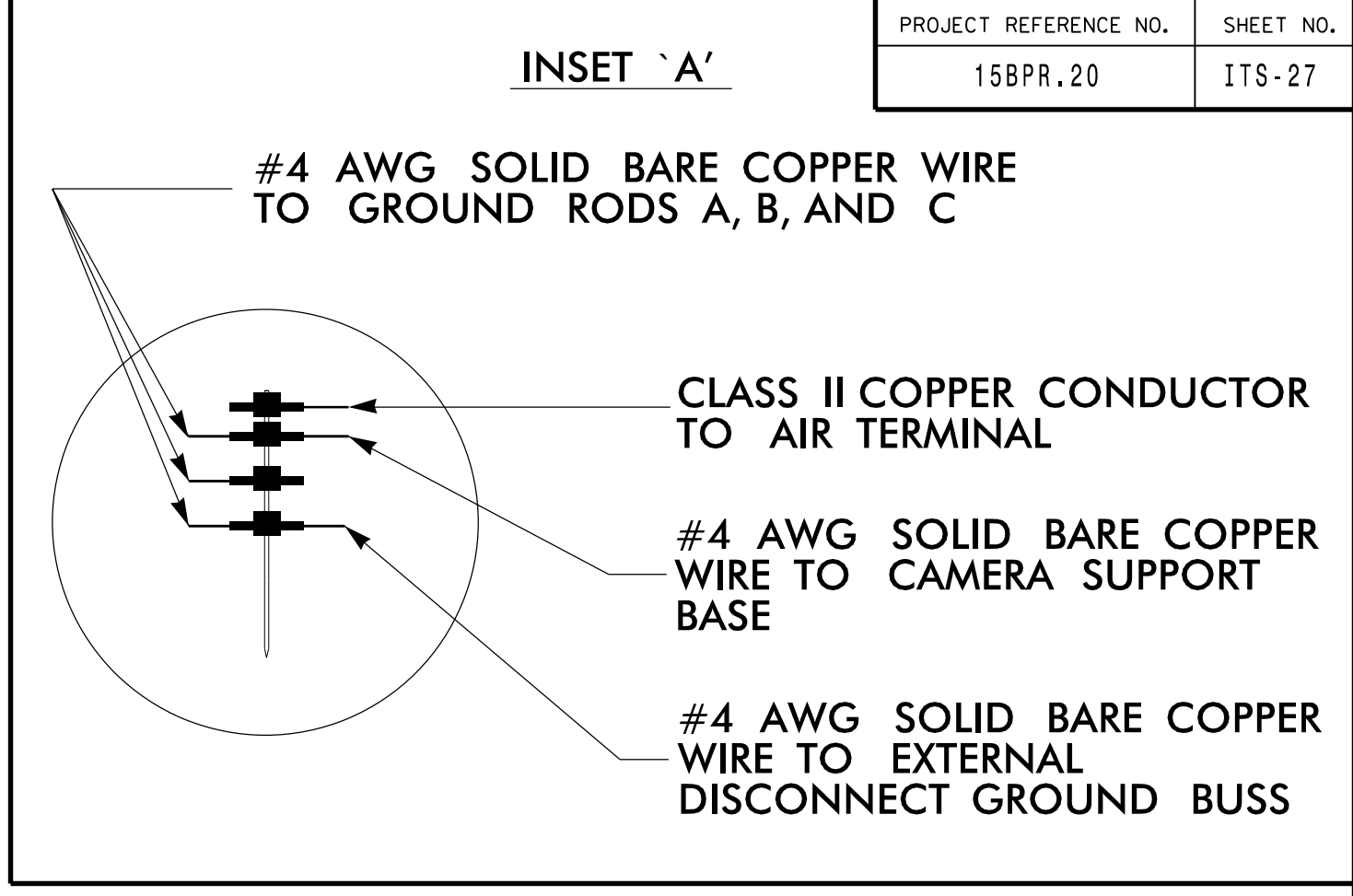
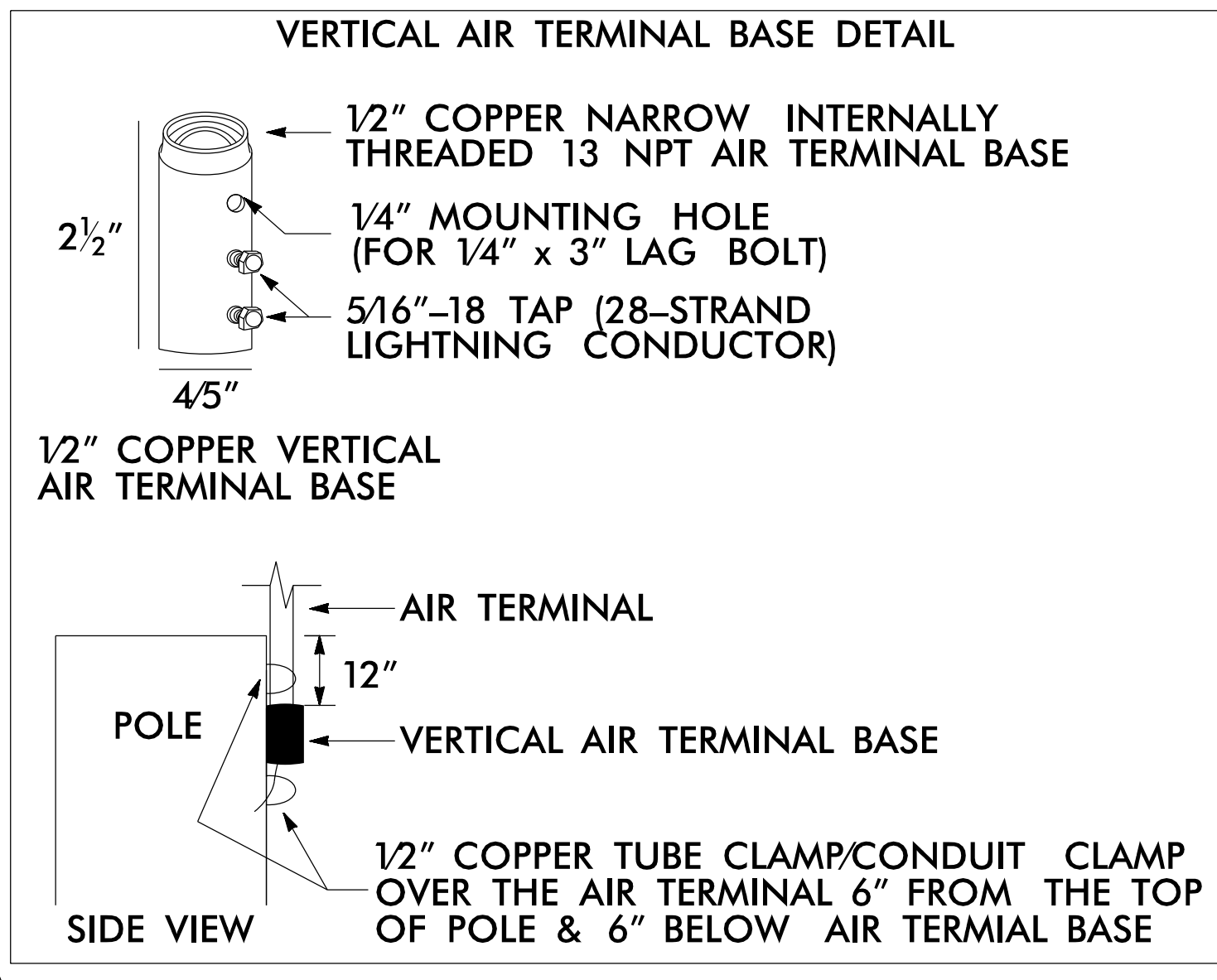
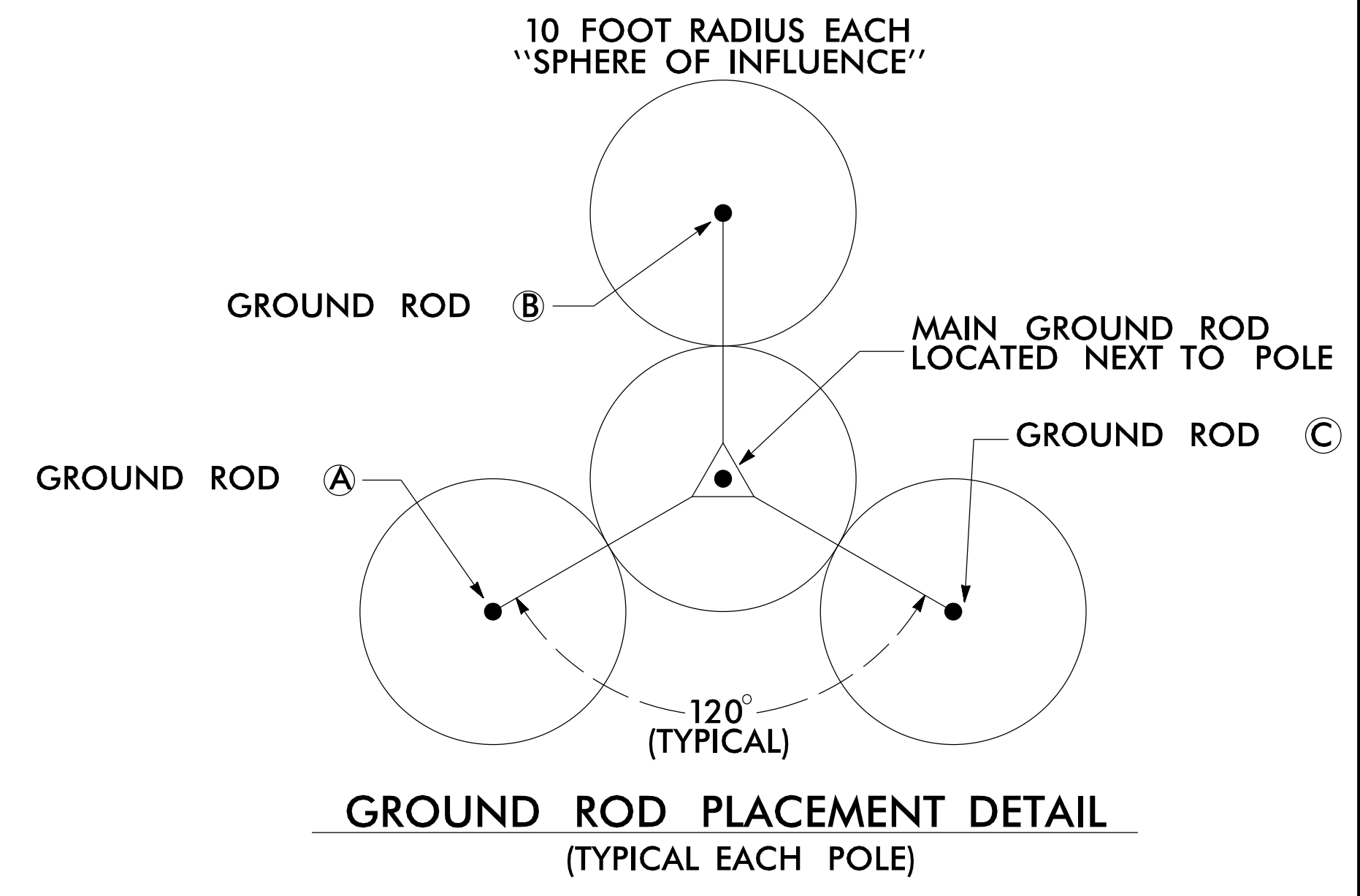

BOND #4 AWG SOLID BARE COPPER WIRE TO CAMERA SUPPORT BASE BY AN ALUMINUM TO COPPER #2 - #14 AWG LUG. ATTACH TO CAMERA BASE WITH A STAINLESS STEEL SELF TAPPING SCREW. REMOVE PAINT OR PROTECTIVE COATING WHERE ATTACHING LUG ONLY.

INSTALL 2-INCH PVC U-GUARD OVER COPPER CONDUCTOR FROM GROUND LEVEL TO 10 FEET (MINIMUM) ABOVE THE GROUND.

2-INCH RIGID GALVANIZED STEEL RISER FOR POWER AND CONTROL WIRES

POLE MOUNT EQUIPMENT CABINET
SEE NOTE 5

1-INCH RIGID GALVANIZED STEEL RISER TO CCTV CABINET

SOLAR EQUIPMENT CABINET

INSTALL MARKER TAPE 12 INCHES BELOW GRADE AND ABOVE ALL GROUNDING CONDUCTORS.

FINISHED GRADE

24 INCH MIN.

IRREVERSIBLE MECHANICAL CRIMP

GROUND ROD A

TO GROUND ROD B

TO GROUND ROD C

MAIN GROUND ROD INDICATED BY "▲" IN GROUND ROD PLACEMENT DETAIL THIS SHEET

5/8 INCH X 10 FOOT MIN. COPPER CLAD STEEL GROUND RODS DRIVEN INTO UNDISTURBED EARTH

10 - 20 FEET

12 INCH MINIMUM

2 INCH CONDUIT FOR FIBER OPTICS

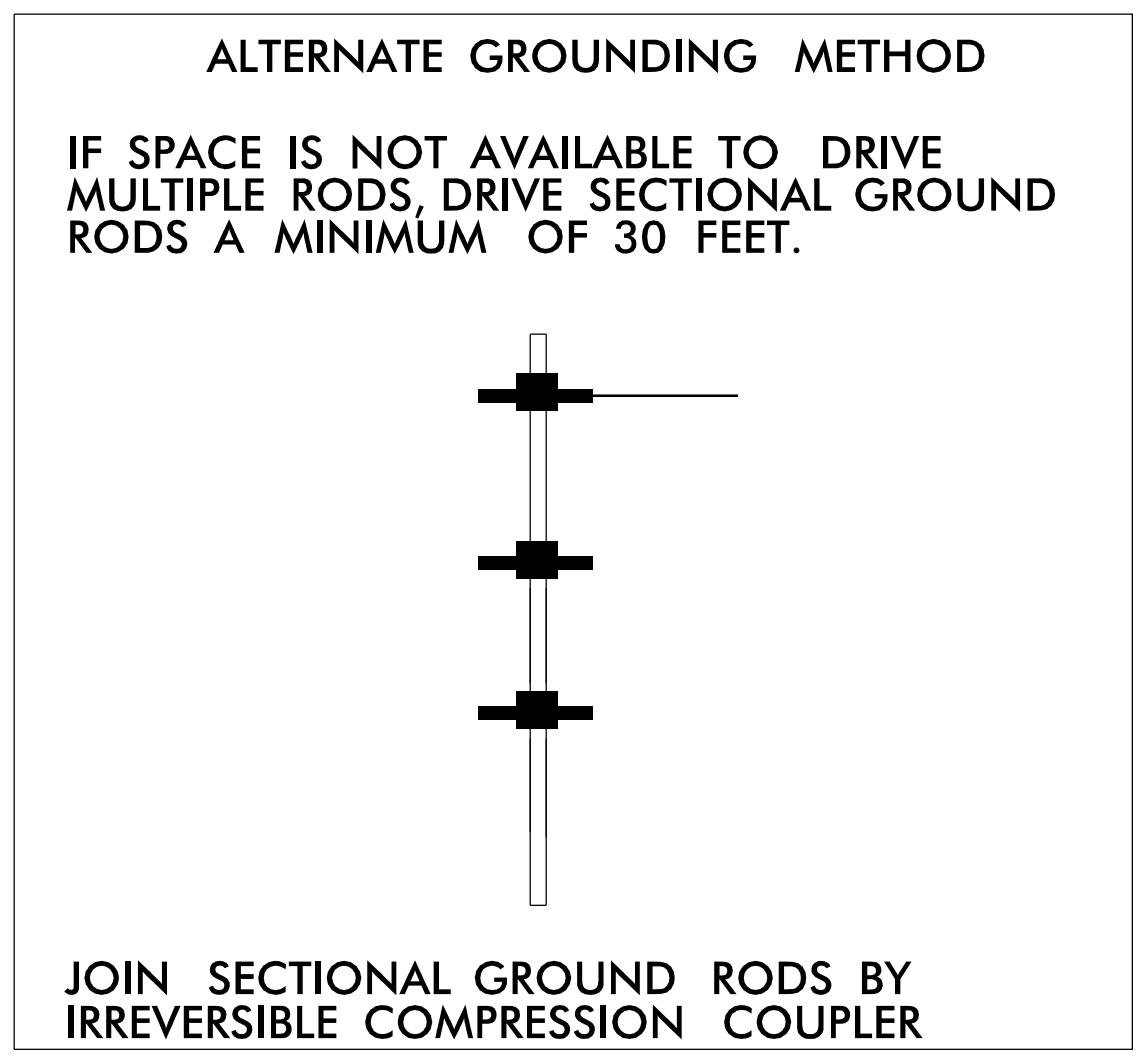

NOTES

1. BOND CLASS II, 28 STRAND (MINIMUM), 15 AWG (MINIMUM) ROPE-LAY BARE COPPER CONDUCTOR TO THE MAIN GROUND ROD BY AN IRREVERSIBLE MECHANICAL CRIMP. MAINTAIN MAXIMUM HORIZONTAL SEPARATION BETWEEN COPPER CONDUCTOR AND RISER.
2. ALL CONNECTIONS TO GROUND RODS SHOULD BE MADE WITH AN IRREVERSIBLE MECHANICAL CRIMP METHOD.
3. REFER TO STANDARD DRAWING 1700-2 FOR ALTERNATE GROUND ROD INSTALLATION METHOD AS APPROVED BY THE ENGINEER.
4. INSTALL MARKER TAPE DIRECTLY ABOVE ALL GROUNDING ELECTRODES AND CONDUCTORS AT A DEPTH OF 12 INCHES.
5. REMOVE BONDING JUMPER BETWEEN EQUIPMENT CABINET GROUND BUSS AND NEUTRAL BUSS.

	<p>CCTV CAMERA INSTALLATION FOR WOOD POLES WITH SOLAR POWERED ELECTRICAL SERVICE TYPICAL DETAIL</p>	
	<p>PLAN DATE: December 2020</p>	<p>REVIEWED BY: F. A. Campbell</p>
<p>PREPARED BY: S. W. Cox</p>	<p>REVIEWED BY:</p>	<p>DATE:</p>
<p>REVISIONS</p>	<p>INIT.</p>	<p>DATE</p>
<p>NTS</p>	<p>DocuSigned by: Francis A. Campbell 12/8/2020</p>	<p>CADD Filename:</p>

NOTES

- FURNISH "TIER 22" RATED JUNCTION BOXES AND COVERS
- SECURE COVER WITH HEX BOLTS.
- COIL AND STORE 6' OF TRACER WIRE JUMPER IN ALL JUNCTION BOXES WITH FIBER OPTIC CABLE.
- BOX INSIDE DIMENSIONS:
 - STANDARD SIZED: 16" (l) x 10" (w) x 10" (d)
 - OVERSIZED: 28" (l) x 15" (w) x 22" (d)
 - SPECIAL OVERSIZED: 33" (l) x 22" (w) x 22" (d)
 - ADDITIONAL SIZES: (_) (l) x (_) (w) x (_) (d)
- PROVIDE 6" & 12" VERTICAL JUNCTION BOX EXTENDERS AS NEEDED

**INSTALLATION CROSS-SECTION
JUNCTION BOX**

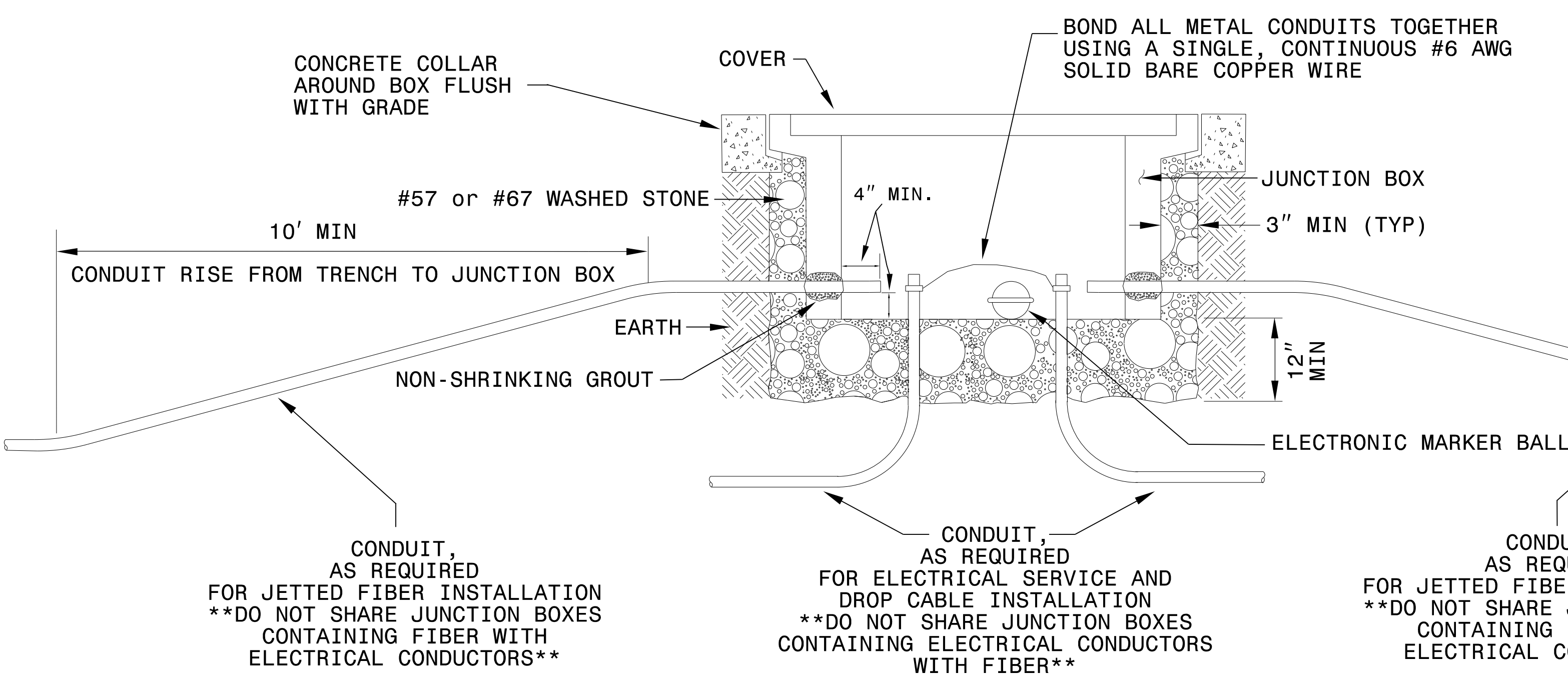

**CONDUIT ENTERING JUNCTION BOX
(JETTED FIBER INSTALLATION)**

- PROVIDE OVERSIZED AND SPECIAL OVERSIZED JUNCTION BOXES WITH MOUSE HOLES, PRECAST KNOCKOUTS OR FIELD DRILL CONDUIT ENTRANCE HOLES.
- FOR ALL OVERSIZED AND SPECIAL OVERSIZED JUNCTION BOXES, ALL CONDUITS SHALL ENTER THROUGH THE SIDEWALL THROUGH THE MOUSE HOLES, PRECAST KNOCKOUTS OR FIELD DRILLED HOLES AND SEALED WITH NON-SHRINKING GROUT. MAINTAIN 4" SEPARATION FROM THE BOTTOM OF THE BOX TO THE CONDUITS. (NO CONDUIT SHALL ENTER FROM THE BOTTOM EXCEPT FOR DROP CABLES TO ITS DEVICES AND FOR STANDARD JUNCTION BOXES FOR ELECTRICAL SERVICE WIRES)
- LEAVE CONDUITS ENTERING SIDES OF JUNCTION BOX OVERLAPPING INITIALLY FOR JETTING PURPOSES. AFTER FIBER IS INSTALLED CUT CONDUIT BACK TO FOUR INCHES FROM THE JUNCTION BOX SIDEWALL.
- SEAL ALL CONDUITS AFTER INSTALLATION WITH MOLDABLE DUCT SEAL. AFTER INSTALLATION OF FIBER CABLE, SEAL CONDUITS WITH A MECHANICAL FIBER/DUCT CONDUIT PLUGS.

ELECTRONIC MARKER BALL
ORANGE BALL - 101.4 kHz - FIBER
RED BALL - 169.8 kHz - POWER

TOP VIEW

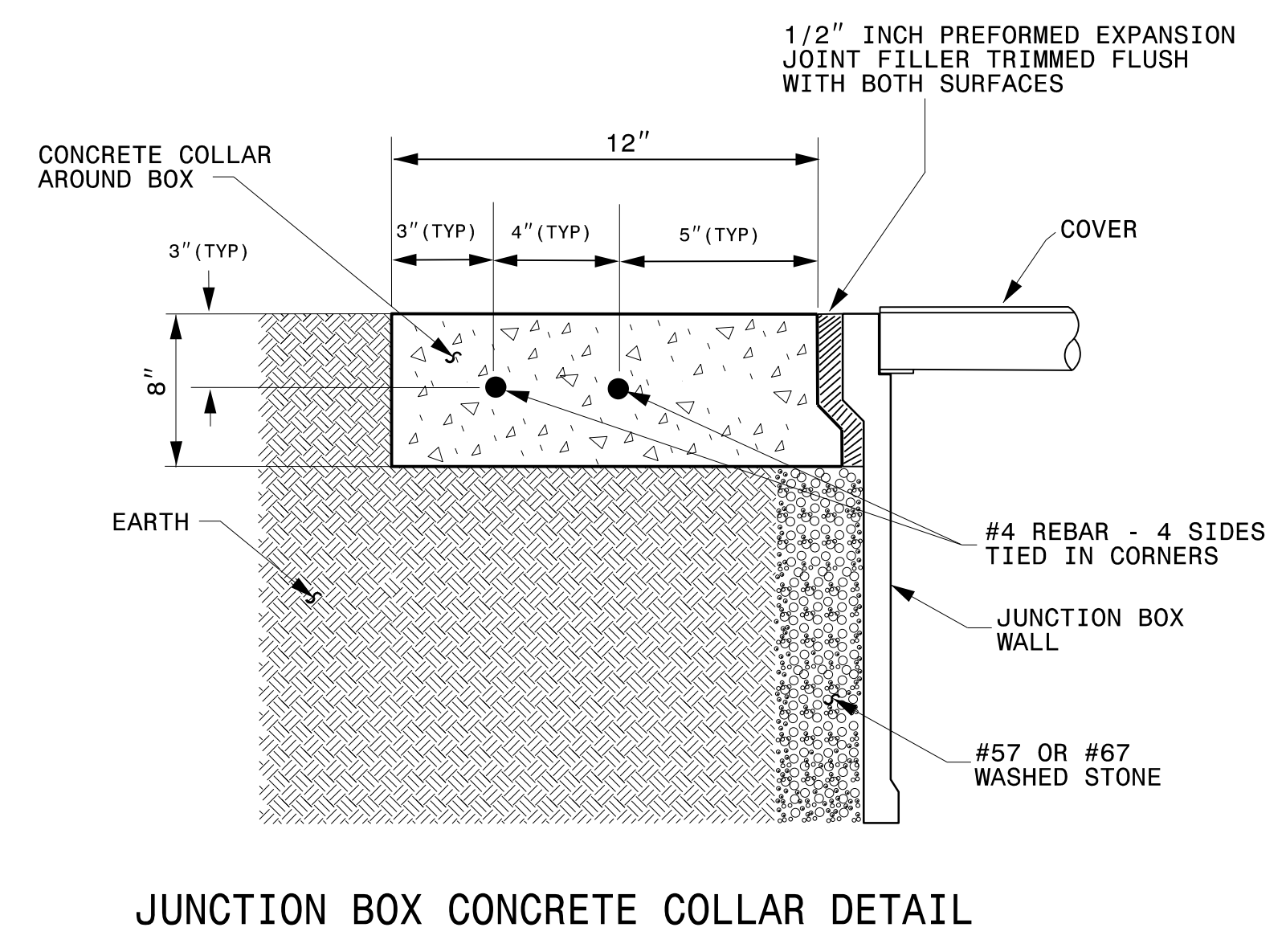
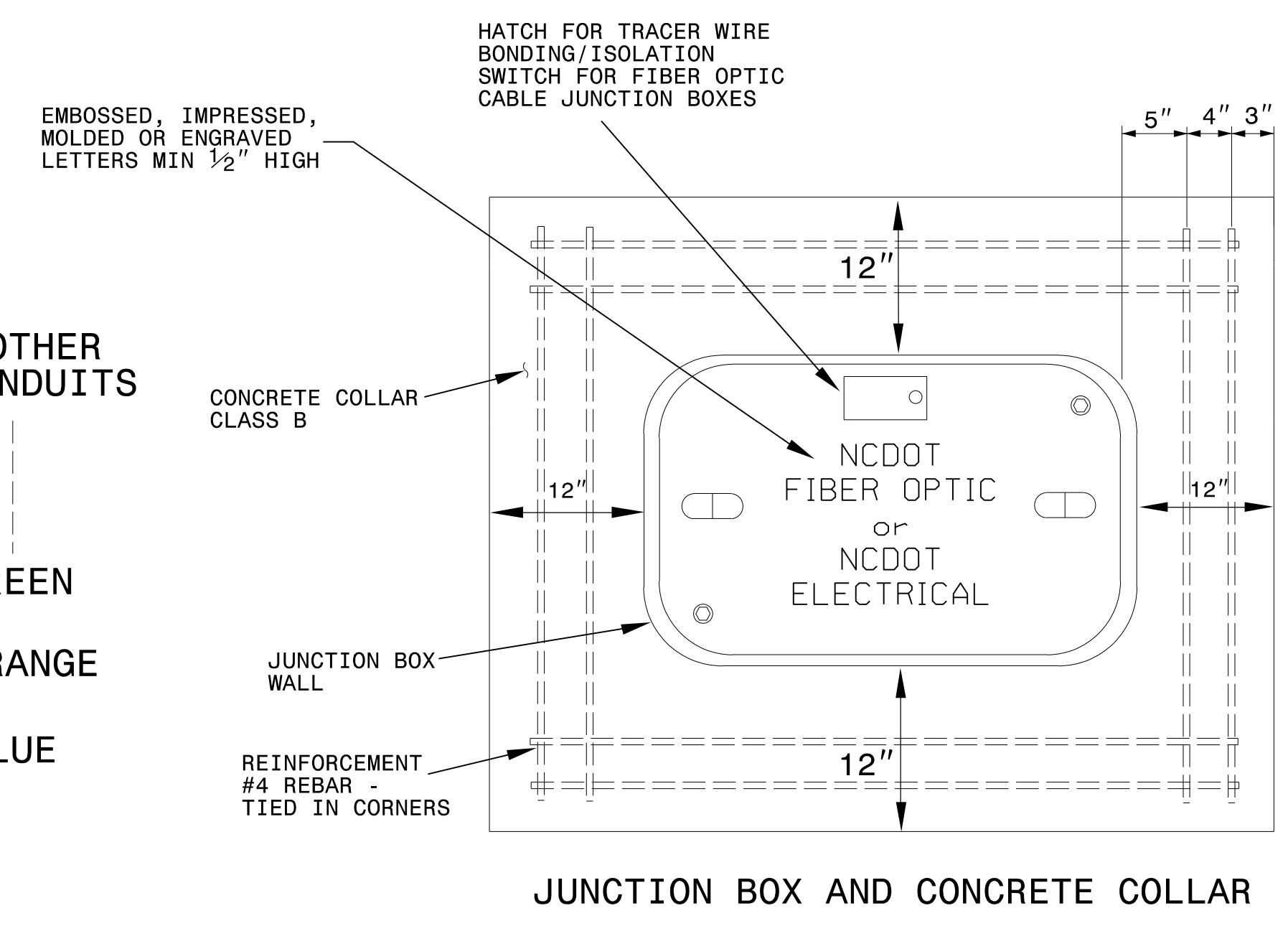
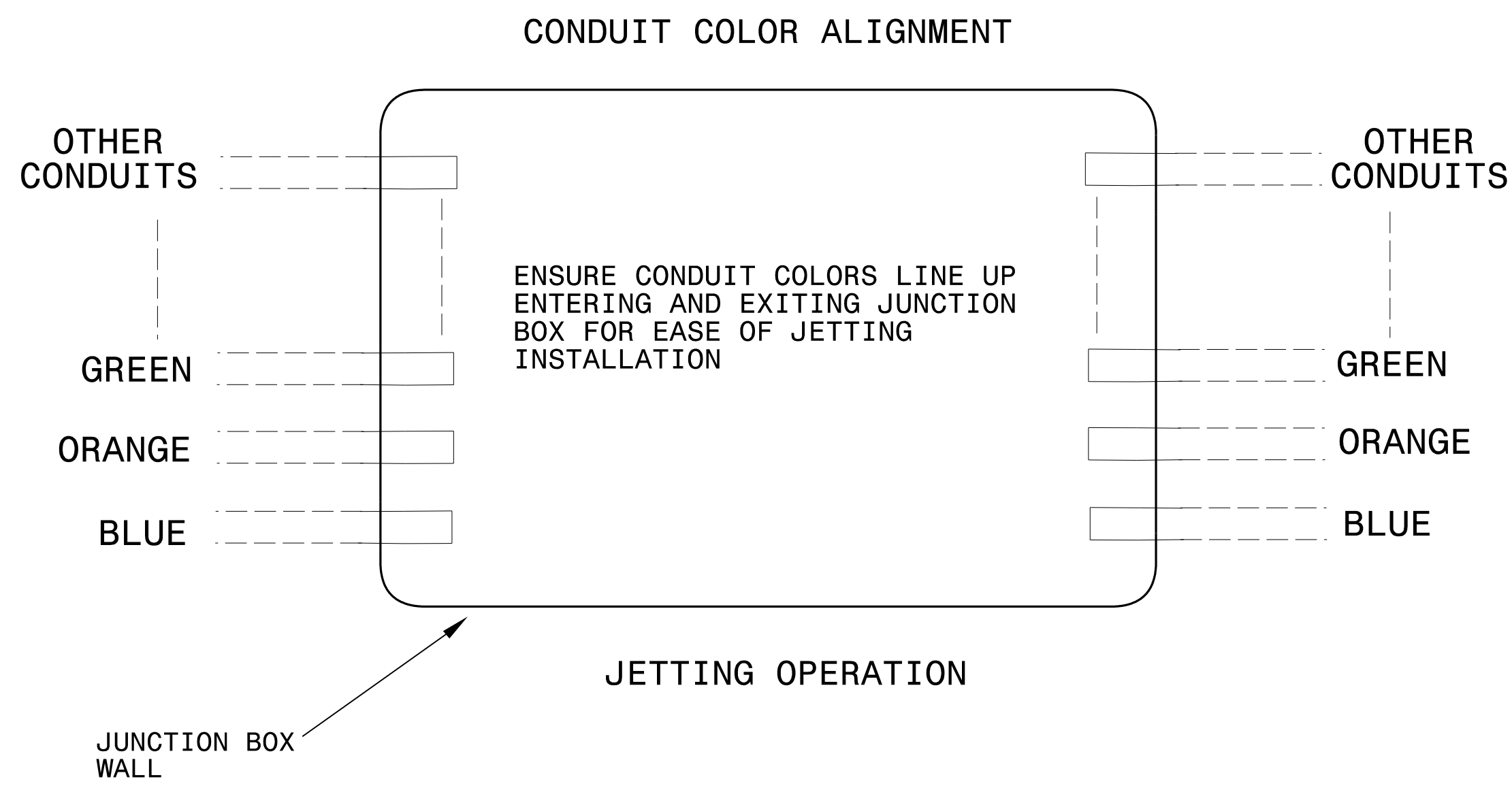

12/17/2020 P:\60587170-1-26_Greenfield\110-CAD\4900-CAD.dwg 10:40:10 AM 12/17/2020 1:26:11 PM ITS-30.dgn



Prepared for the Offices of:

Limited Access Junction Box

Installation Detail

PLAN DATE: December 2020 REVIEWED BY: F. A. Campbell

PREPARED BY: S. W. Cox REVIEWED BY:

REVISIONS

SCALE: 0 NA N.T.S.

DOCUMENT NOT CONSIDERED FINAL UNLESS ALL SIGNATURES COMPLETED

SEAL 041673

ENGINEER F. A. CAMPBELL

DocuSigned by: **France Campbell** 12/8/2020

TRACER WIRE INSTALLATION CROSS-SECTION COMMUNICATIONS CABLE JUNCTION BOX

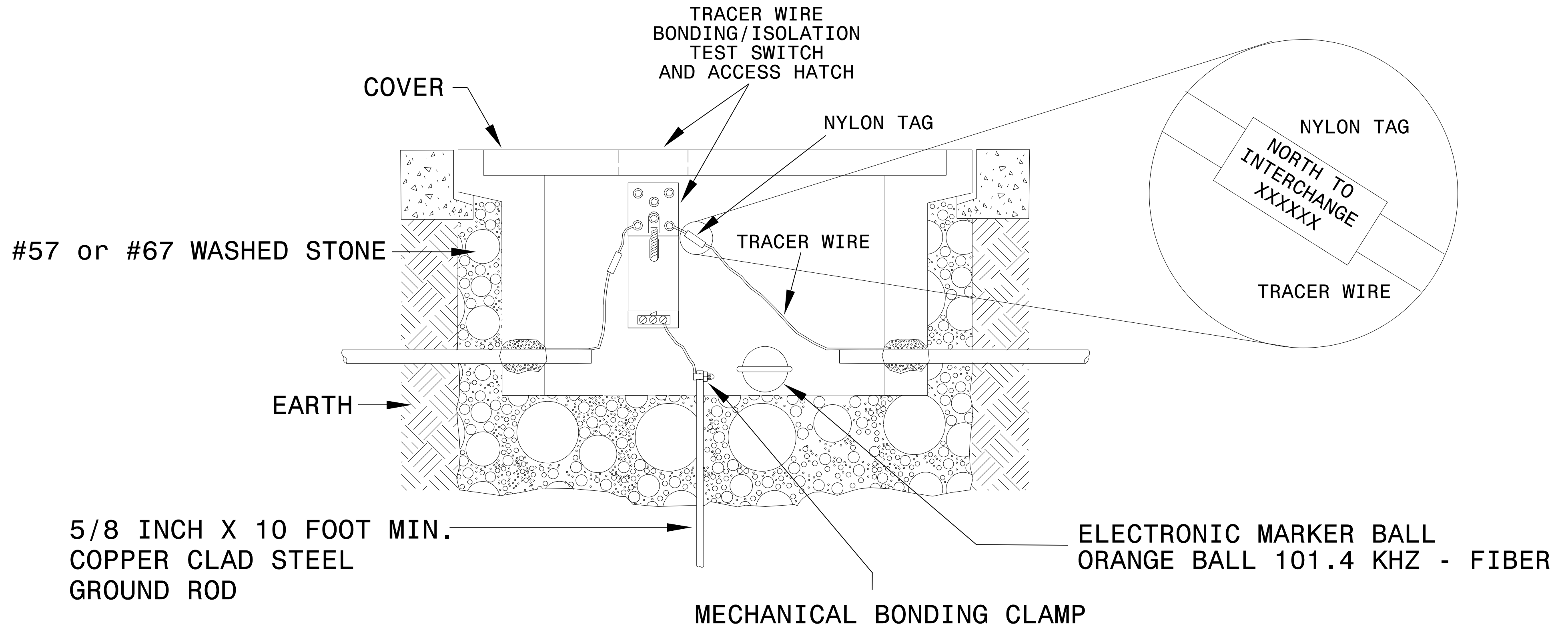

NOTES

1. TEST JUNCTION BOX GROUNDING FOR 20 OHMS OR LESS. DRIVE A SECOND GROUND ROD IF 20 OHMS CANNOT BE ACHIEVED.
2. COIL FIVE FEET OF SPARE TRACER WIRE AND GROUND ROD BONDING JUMPER IN EACH JUNCTION BOX.

TOP VIEW

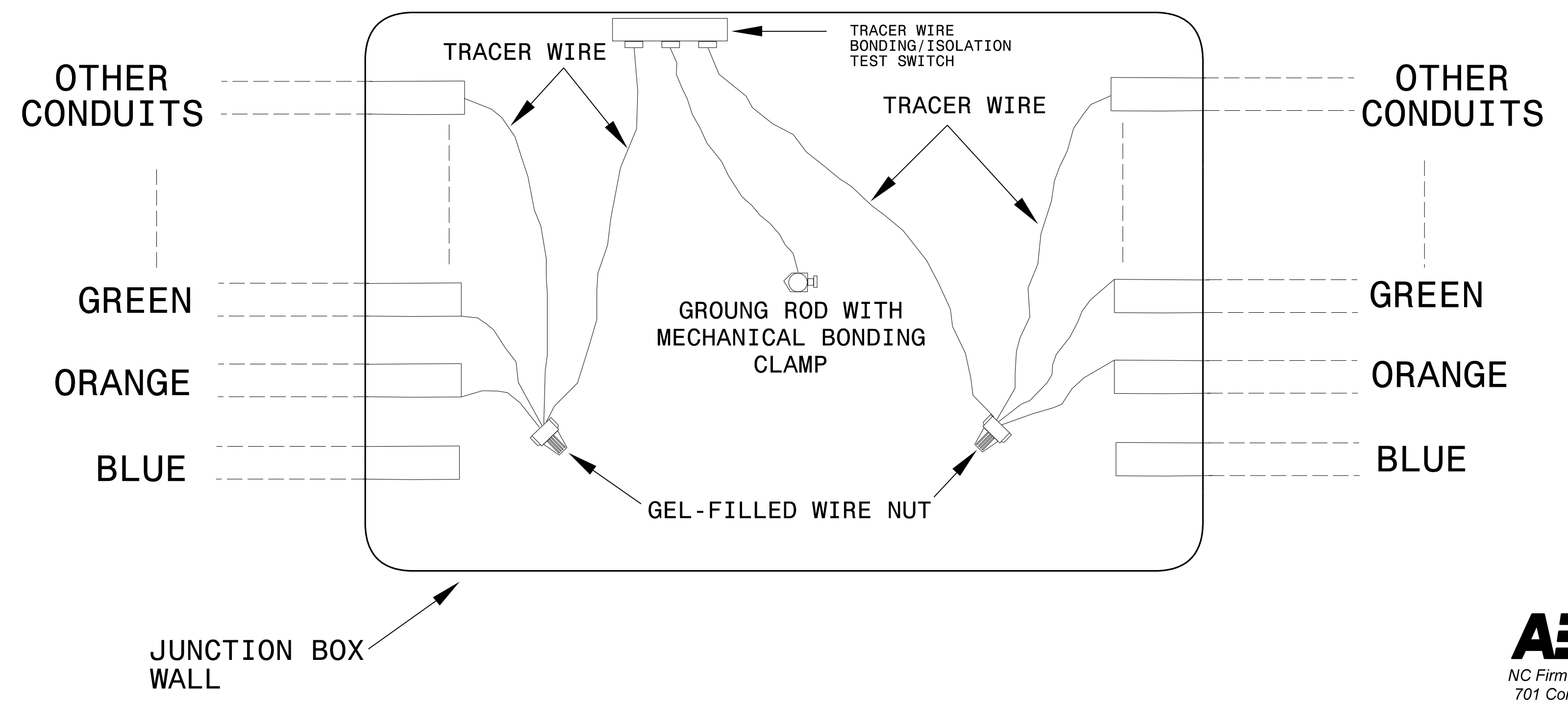

12/7/2020
 P:\060881170-1-26_Greenfield_Pkwy-701-CAD\W70_NCDOT_TIP\Traffic\GIS\060881170-1-26_ITS_P5132.dgn
 michael.covernaugh

AECOM
 NC Firm License No.: F-0342
 701 Corporate Center Drive
 Suite 475 Raleigh, NC 27607
 Phone: 919-854-6200

Prepared for the Offices of:

750 N. Greenfield Pkwy., Garner, NC 27529
 SCALE: 0 NA
 N.T.S.

Tracer Wire Bonding/Isolation Test Switch Detail
 Communication Junction Box Only

PLAN DATE: December 2020	REVIEWED BY: F. A. Campbell
PREPARED BY: S. W. Cox	REVIEWED BY:
REVISIONS	INIT. DATE

DOCUMENT NOT CONSIDERED FINAL UNLESS ALL SIGNATURES COMPLETED

Documented by:
France Campbell 12/8/2020
 CADD Filename: