

3 Phase Fully Actuated w/ Emergency Vehicle Preemption SR 1007 (Mebane Oaks Rd) CLS Signal System #: 10705

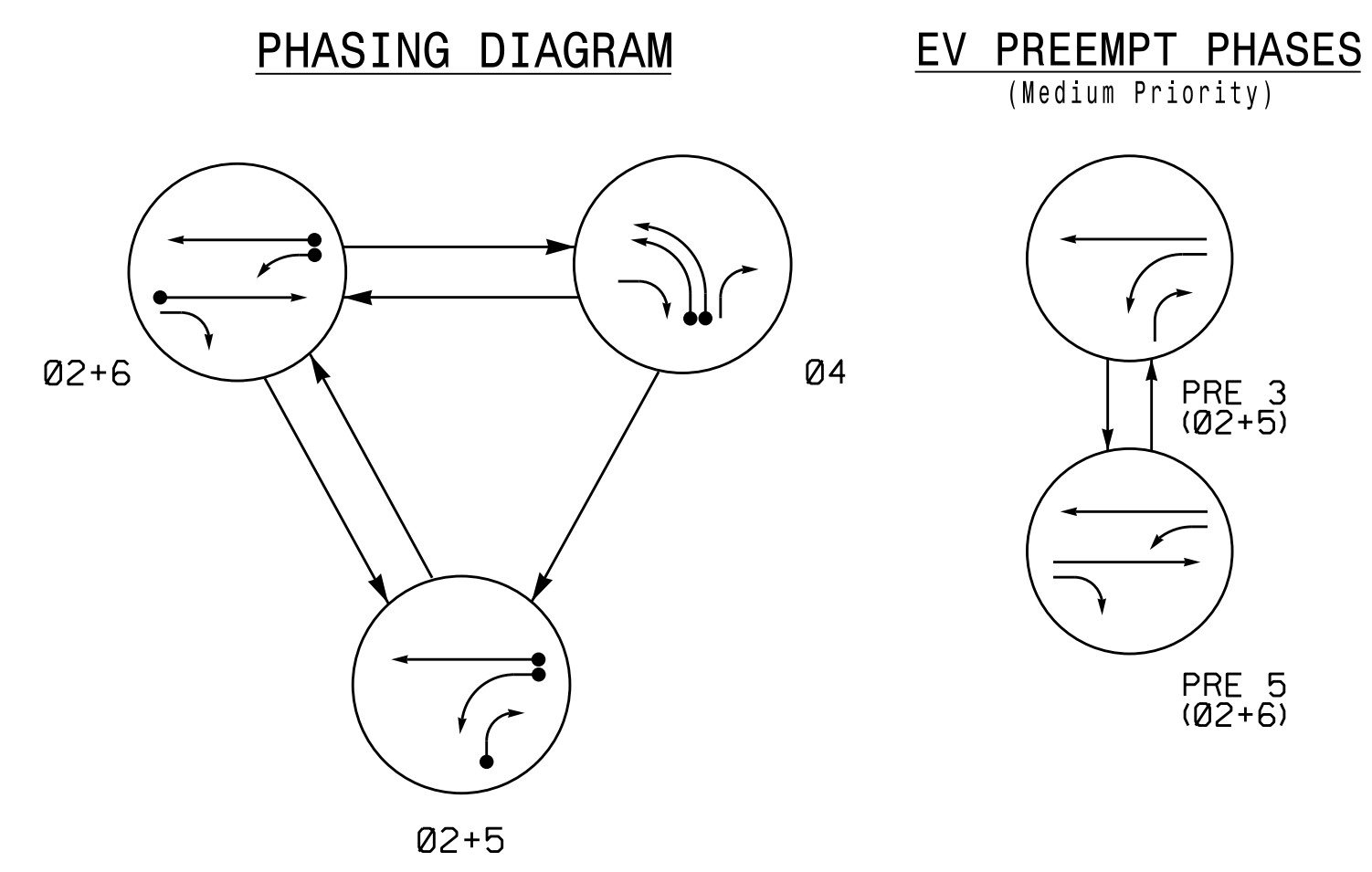

SIGNAL FACE	PHASE					
	02+5	02+6	04	PRE 3	PRE 5	FLASH
21, 22	G	G	R	G	G	Y
41, 42	R	R	L	R	R	R
43	L	R	L	R	R	R
51	L	R	R	L	R	Y
61	R	G	R	R	G	Y
62	R	G	R	R	G	Y

ZONE	SIZE (FT)	DISTANCE FROM STOPBAR (FT)	TURNS	NEW LOOP	PROGRAMMING							
					PHASE	CALLING	EXTEND TIME	DELAY TIME	USE ADDED INITIAL	TYPE	SYSTEM LOOP	NEW CARD
2A/S13	6X6	300	*	*	2	Yes	-	-	X	N	X	*
4A	6X40	0	*	*	4	Yes	-	3	-	S	-	*
4B	6X40	0	*	*	4	Yes	-	-	-	S	-	*
5A	6X40	0	*	*	5	Yes	-	15	-	S	-	*
5B	6X40	0	*	*	2	Yes	-	3	-	G	-	*
6A/S11	6X6	300	*	*	6	Yes	-	-	X	N	X	*
S12	6x6	300	*	*	-	No	-	-	-	N	X	*
S15	6x6	+145	*	*	-	No	-	-	-	N	X	*
S16	6x6	+145	*	*	-	No	-	-	-	N	X	*

SIGNAL FACE I.D.

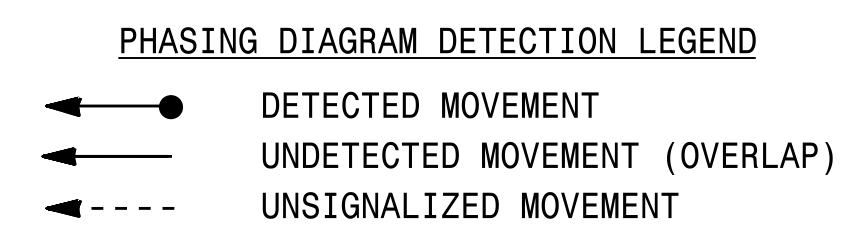
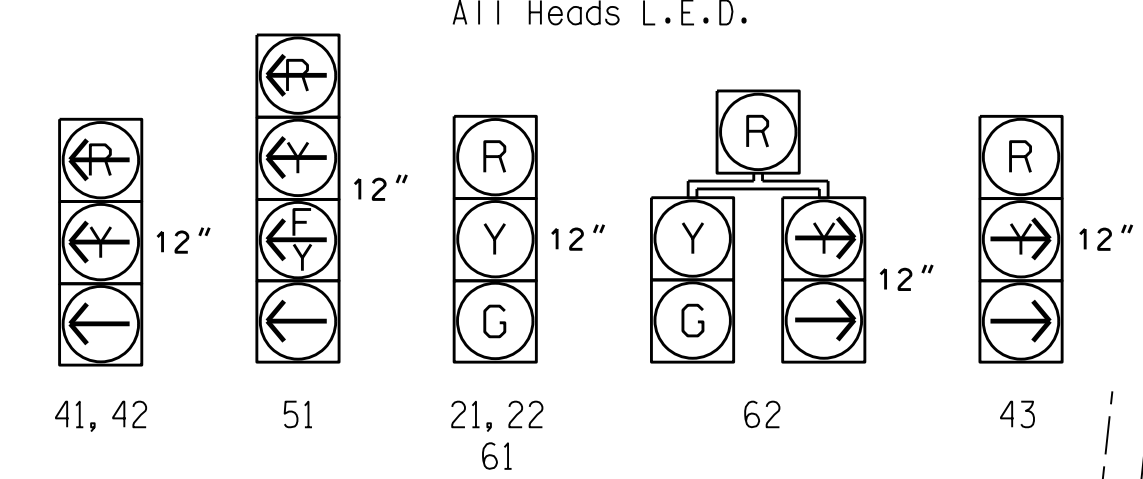

- NOTES
- Refer to "Roadway Standard Drawings NCDOT" dated January 2018 and "Standard Specifications for Roads and Structures" dated January 2018.
 - Do not program signal for late night flashing operation unless otherwise directed by the Engineer.
 - Phase 5 may be lagged.
 - Set all detector units to presence mode.
 - Locate new cabinet so as not to obstruct sight distance of vehicles turning right on red.
 - Pavement markings are existing.
 - Relocate the existing GPS Emergency Vehicle Preemption system.
 - Maximum times shown in timing chart are for free-run operation only. Coordinated signal system timing values supersede these values.
 - Closed loop system data: Controller Asset #: 2060.

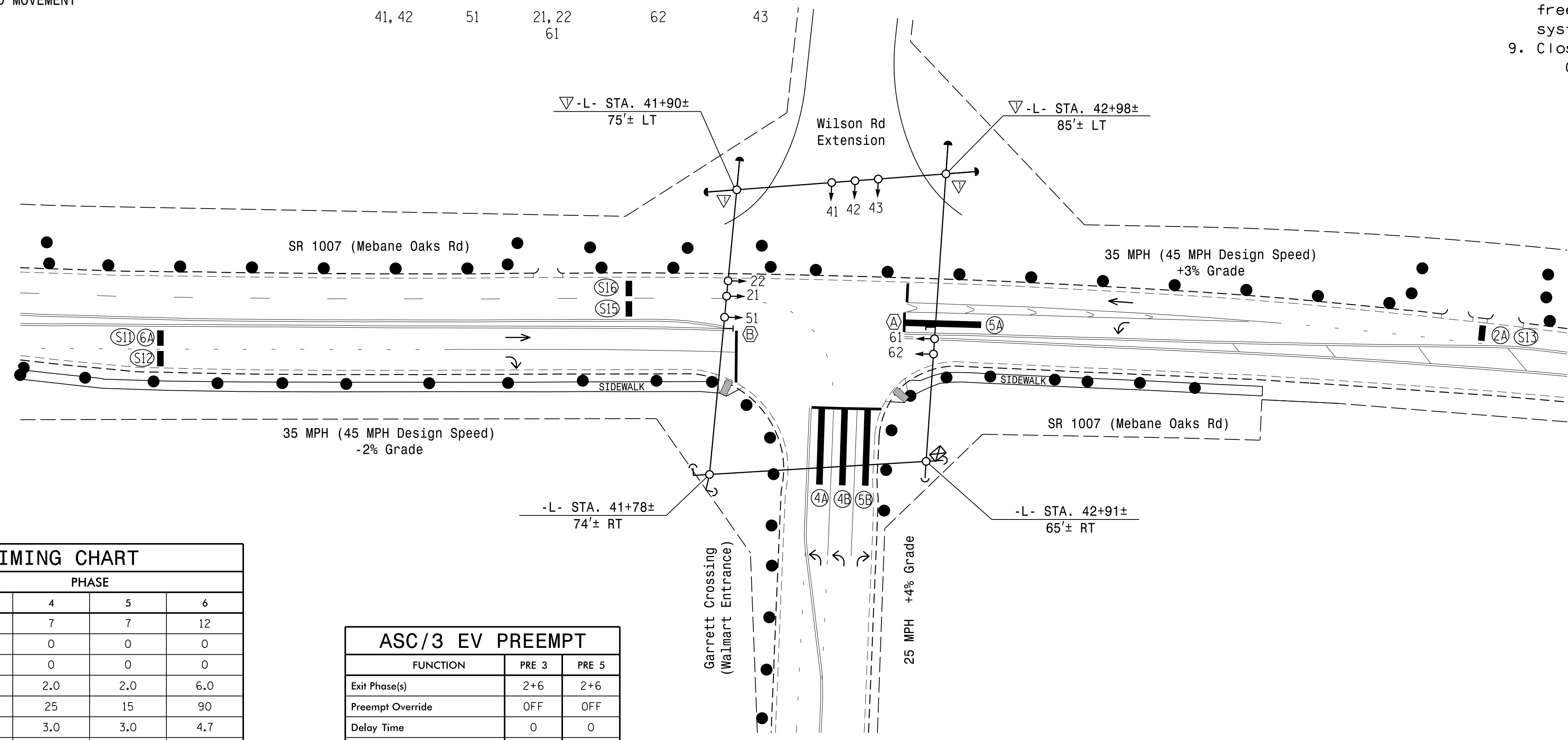

FEATURE	PHASE			
	2	4	5	6
Min Green *	12	7	7	12
Walk *	0	0	0	0
Ped Clear	0	0	0	0
Veh. Extension *	6.0	2.0	2.0	6.0
Max 1 *	90	25	15	90
Yellow	4.7	3.0	3.0	4.7
Red Clear	1.2	2.4	2.1	1.2
Red Revert	2.0	2.0	2.0	2.0
Actuations B4 Add *	0	-	-	0
Seconds /Actuation *	2.5	-	-	2.5
Max Initial *	34	-	-	34
Time Before Reduction *	15	-	-	15
Time To Reduce *	30	-	-	30
Minimum Gap	3.0	-	-	3.0
Locking Detector	X	-	-	X
Recall Position	VEH. RECALL	-	-	VEH. RECALL
Dual Entry	-	-	-	-
Simultaneous Gap	X	X	X	X

FUNCTION	PRE 3	PRE 5
Exit Phase(s)	2+6	2+6
Preempt Override	OFF	OFF
Delay Time	0	0
Ped Clear Through Yellow	N	N
Terminate Phases	N	N
Entrance Walk	255*	255*
Entrance Ped Clear	255*	255*
Entrance Min Green	1	1
Entrance Yellow Clear	25.5*	25.5*
Entrance Red Clear	25.5*	25.5*
Min Dwell Time	7	7
Preempt Input Extension Time	2	2
Preempt Max Time	120	120
Exit Yellow Clear	25.5*	25.5*
Exit Red Clear	25.5*	25.5*

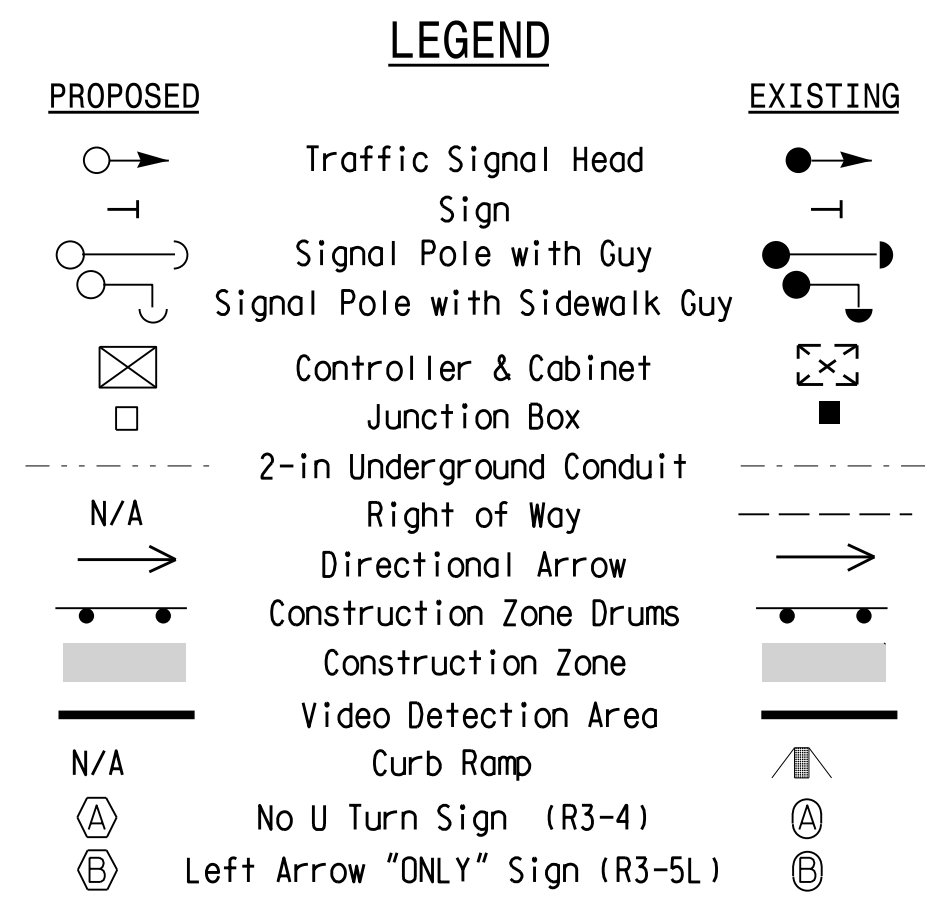

* These values may be field adjusted. Do not adjust Min Green and Extension times for phases 2 and 6 lower than what is shown. Min Green for all other phases should not be lower than 4 seconds.

* Time defaults to time used for phase during normal operation

Signal Upgrade - Temporary Design 1 (TMP Phase I)

PREPARED IN THE OFFICE OF:
Accelerate Engineering, PLLC
 875 Walnut Street, Suite 316
 Cary, NC 27511
 Tel: 919.263.5678 Fax: 919.263.5687
 NC License No. P-1442

REVISION SEAL
 NORTH CAROLINA PROFESSIONAL ENGINEER
 SEAL 026486
 ROBERT J. ZIEGLER
 6/10/2021
 DATE

TRANSPORTATION MOBILITY AND SAFETY DIVISION
 NORTH CAROLINA DEPARTMENT OF TRANSPORTATION
 Signal Design Section
 750 N. Greenfield Pkwy, Garner, NC 27529

SR 1007 (Mebane Oaks Rd) at Garrett Crossing (Walmart Entrance)
 Division 7 Alamance County Mebane
 PLAN DATE: November 2019 REVIEWED BY: Z. "Gavin" Teng
 PREPARED BY: Z. "Gavin" Teng REVIEWED BY:
 REVISIONS
 REVISED POLE LOCATIONS FOR WILSON RD EXT.
 INJd DATE 6/10/21

DOCUMENT NOT CONSIDERED FINAL UNLESS ALL SIGNATURES COMPLETED
 Not a certified document as to the Original Document but Only as to the Revisions - This document originally Issued and sealed by Zhaolong Teng, PE, #032179, on 12/17/2019. This document is only certified as to the revisions.
 DATE
 SIG. INVENTORY NO. 07-2060T1

I:\0-Utility\2021_12\20 S:\Projects\ASU\115_Signal\Signal_Central\Region\01v_741-5711\07-2060_rev072060T1_510_rev_20210616.dgn
 RZT:embo