

8/17/19

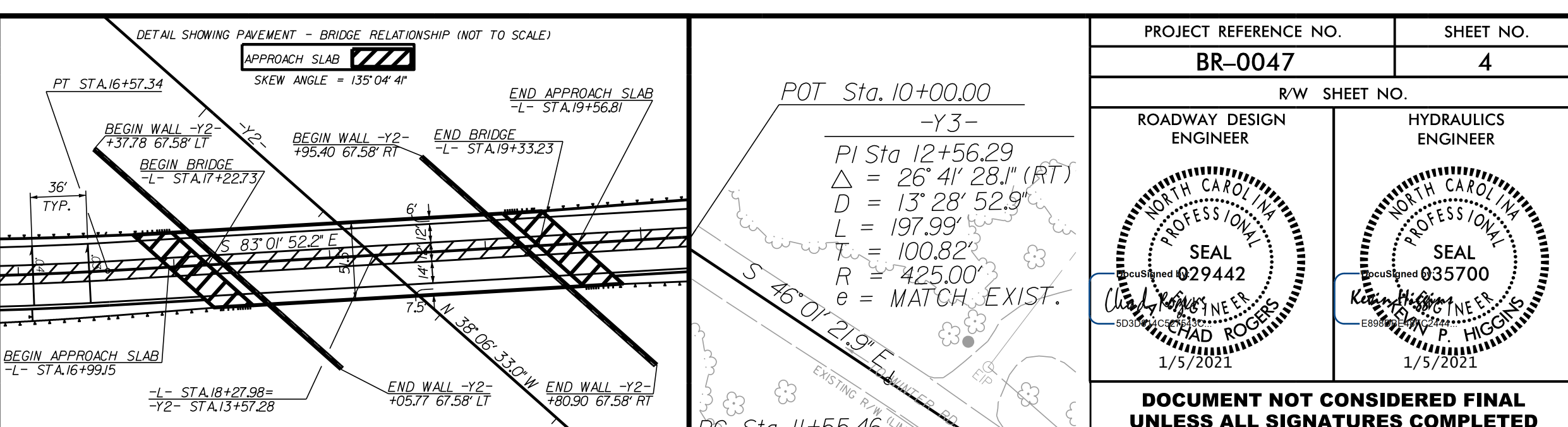

PROJECT REFERENCE NO. <b>BR-0047</b>	SHEET NO. <b>4</b>
R/W SHEET NO.	
ROADWAY DESIGN ENGINEER	HYDRAULICS ENGINEER
DOCUMENT NOT CONSIDERED FINAL UNLESS ALL SIGNATURES COMPLETED	

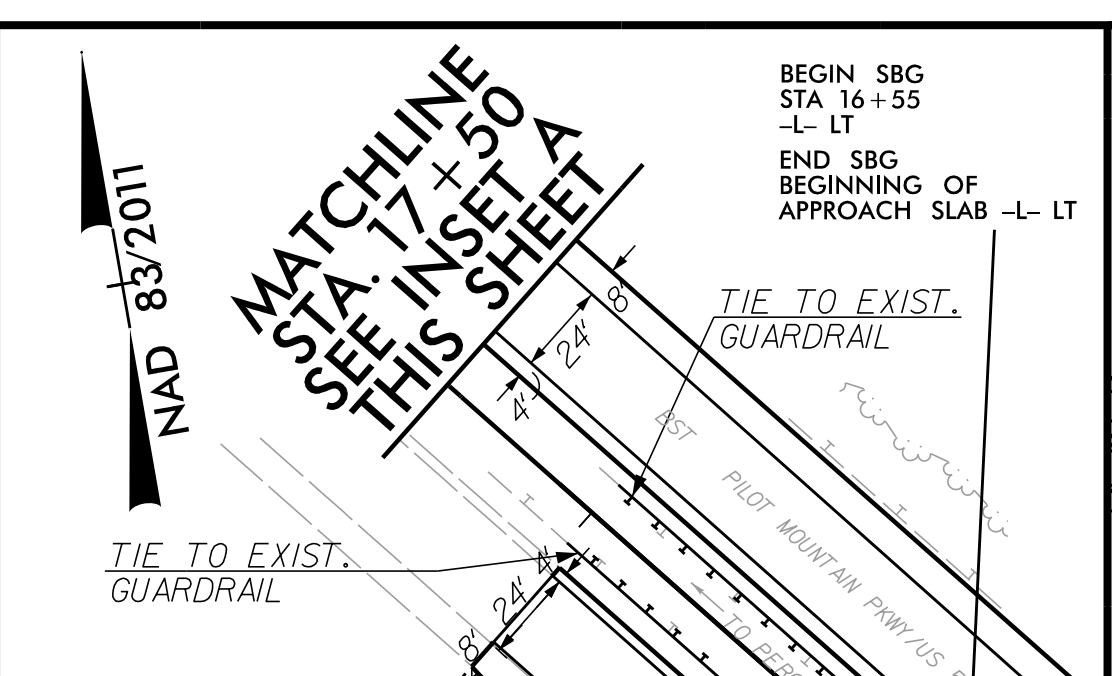
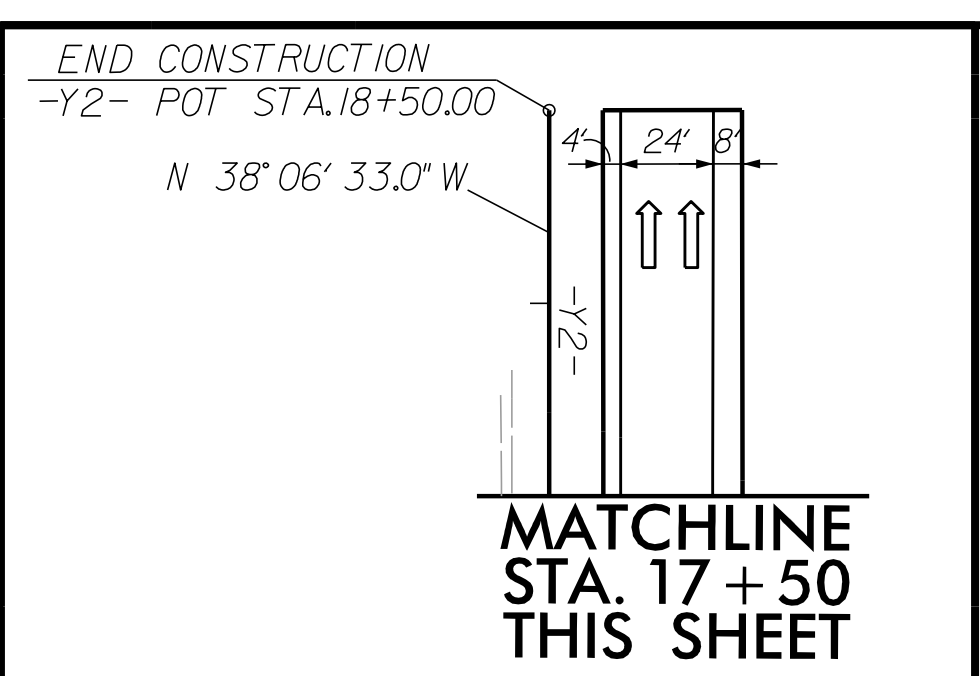
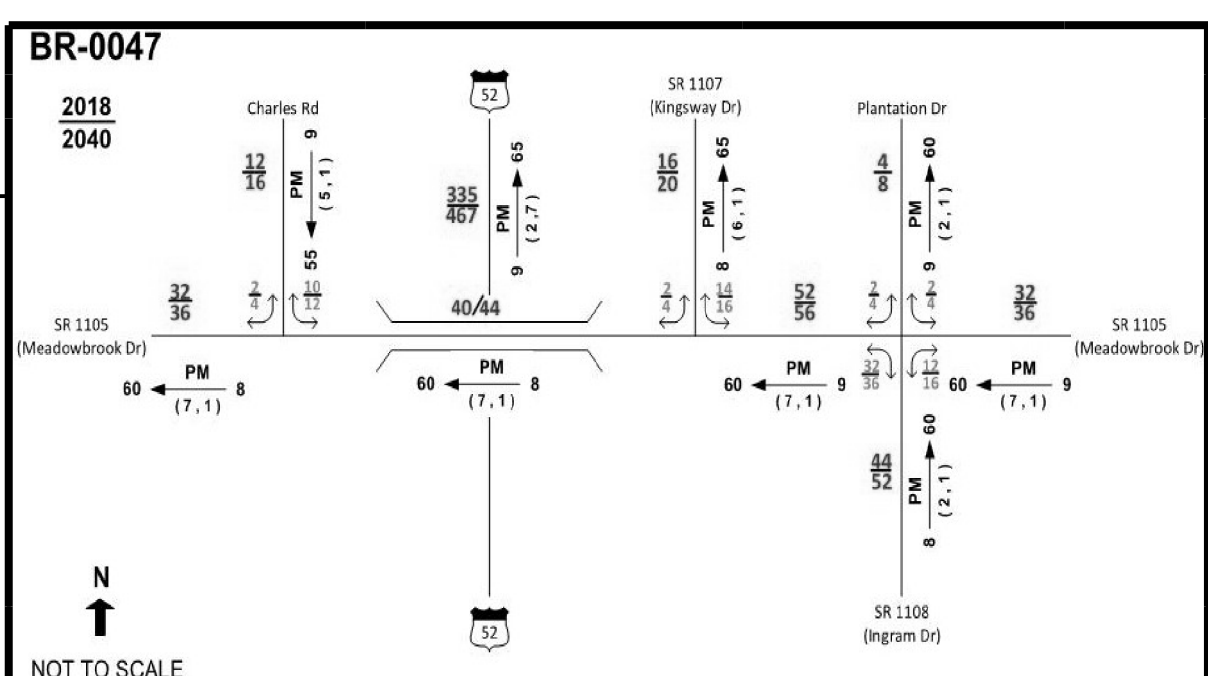
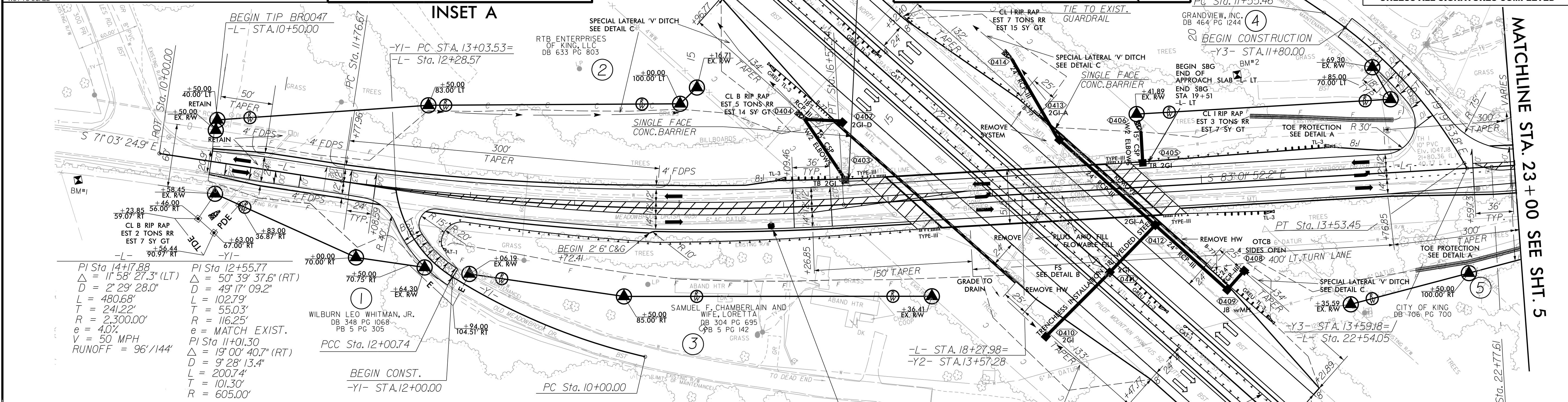

NOTES:  
SEE SHEET 6 FOR -Y1- & -Y3- PROFILES  
SEE SHEET S-1 THRU S-39 FOR STRUCTURE PLANS

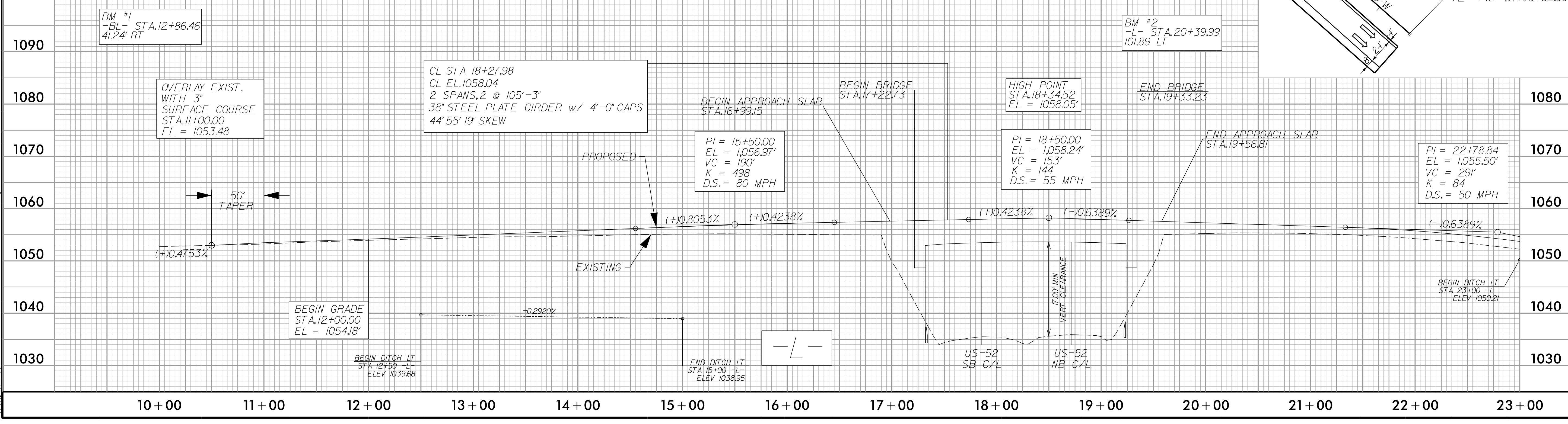

REVISIONS

1/5/2021  
1:45:46 PM  
C:\S\BR0047\_RDY\_PSH04.dgn