

PLAN OF CAP

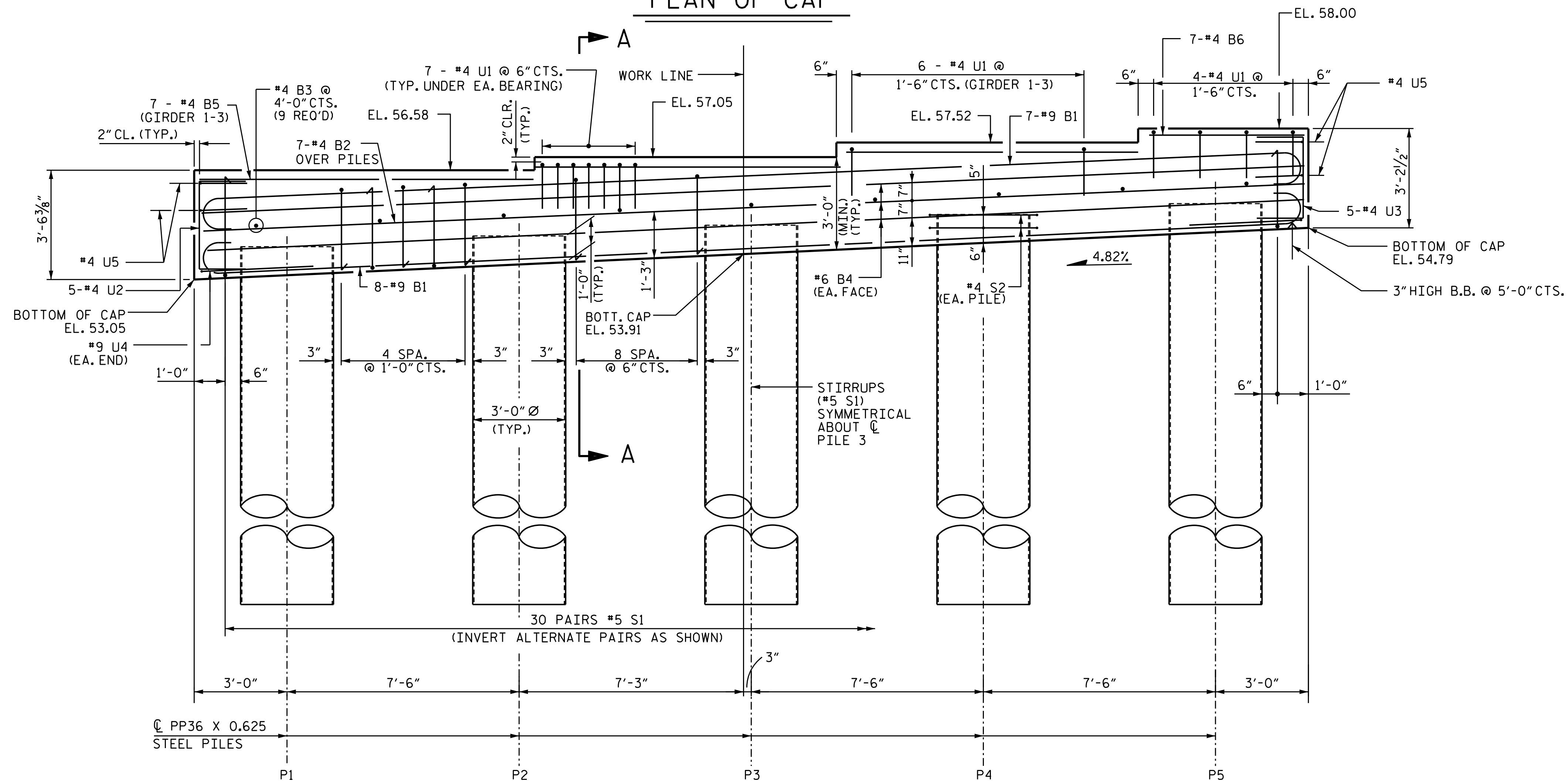

ELEVATION

NOTES

STIRRUPS IN CAP MAY BE SHIFTED AS NECESSARY TO CLEAR ANCHOR BOLTS.
 GALVANIZE THE TOP OF EACH INTERIOR BENT PILE A MINIMUM OF 70'. GALVANIZE IN ACCORDANCE WITH SECTION 1076 OF THE STANDARD SPECIFICATIONS.
 FOR CONCRETE PLUG AND REINFORCING IN PILES SEE "36" STEEL PIPE PILE" SHEET.
 FOR SECTION A-A SEE SHEET 2 OF 2

TOP OF PILE ELEVATIONS	
P1	54.27
P2	54.63
P3	54.99
P4	55.35
P5	55.71

PROJECT NO. B-5671
EDGEcombe COUNTY
 STATION: 17+00.00 -L-

SHEET 1 OF 2

STATE OF NORTH CAROLINA
 DEPARTMENT OF TRANSPORTATION
 RALEIGH

SUBSTRUCTURE BENT 1

DocuSigned by:
 DB3CB8E45B06D498

PROFESSIONAL SEAL
 14114
 ROBERT C. LARSON

DESIGN ENGINEER OF RECORD: [Signature] DATE: 1/24/2020
 DRAWN BY: R.J. FLORY DATE: 10/24/19
 CHECKED BY: R.C. LARSON DATE: 10/30/19

DOCUMENT NOT CONSIDERED FINAL
 UNLESS ALL SIGNATURES COMPLETED

REVISIONS		SHEET NO.	
NO.	DATE	NO.	DATE
1		3	
2		4	

TOTAL SHEETS: 29

KCI PROJ. #251801945.24

1/24/2020

KCI Associates
 of North Carolina, P.A.
 4005 Falls of Neuse Road, Suite 400 Raleigh, NC 27609-6270 Phone 919-785-5241