

PLAN OF CAP

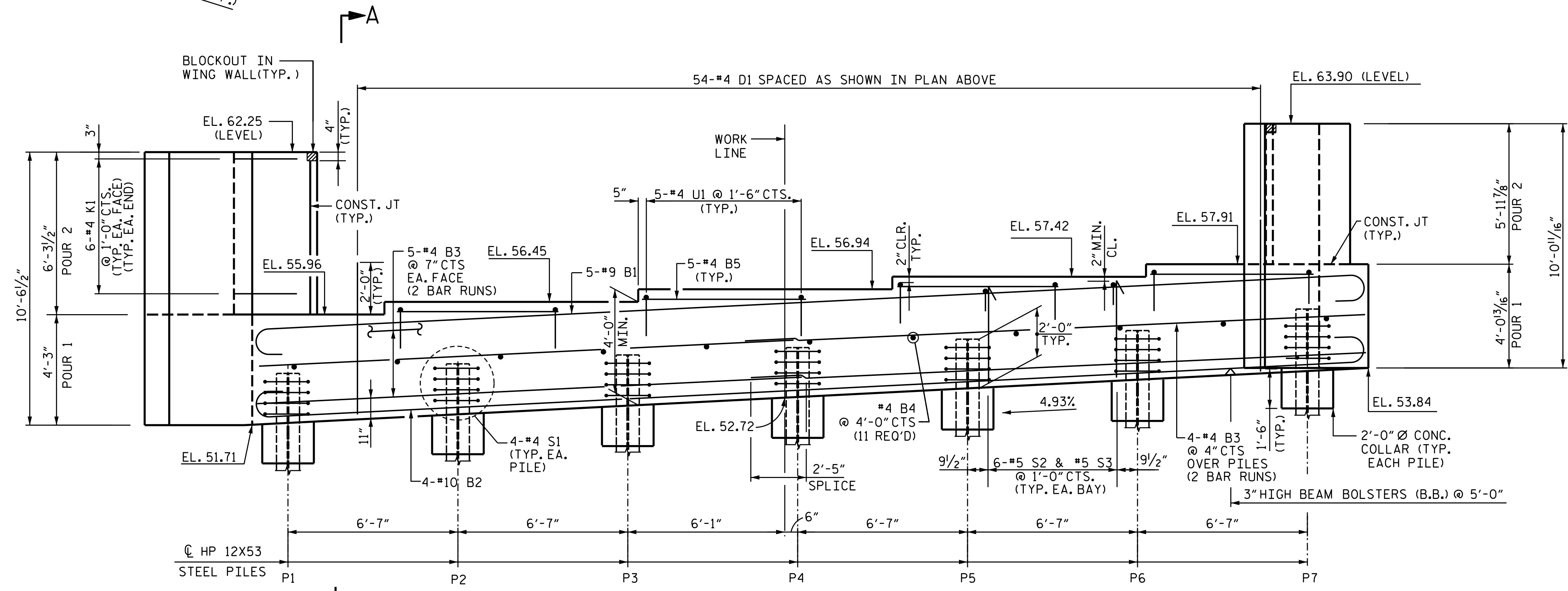

ELEVATION

NOTES

- THE TOP SURFACE OF THE END BENT CAP AND WINGS (POUR 1) EXCEPT THE BEARING AREAS AND THE AREA OUTSIDE OF THE SUPERSTRUCTURE SHALL BE RAKED TO A DEPTH OF 1/4"
- THE CONCRETE IN THE SHADED AREA OF THE WING SHALL BE POURED AFTER THE BARRIER RAIL IS CAST IF SLIPFORMING IS USED.
- FOR "TEMPORARY DRAINAGE AT END BENT", SEE END BENT 2.
- FOR SECTION A-A SEE SHEET 3 OF 3.

TOP OF PILE ELEVATIONS	
P1	53.80
P2	54.12
P3	54.44
P4	54.77
P5	55.09
P6	55.42
P7	55.74

PROJECT NO. B-5671
EDGECOMBE COUNTY
 STATION: 17+00.00 -L-

SHEET 1 OF 3

STATE OF NORTH CAROLINA
 DEPARTMENT OF TRANSPORTATION
 RALEIGH

**SUBSTRUCTURE
 END BENT 1**



DESIGN ENGINEER OF RECORD: [Signature] DATE: 1/24/2020
 DRAWN BY: A. K. ALLANKI DATE: 08/29/19
 CHECKED BY: R. C. LARSON DATE: 08/30/19

**DOCUMENT NOT CONSIDERED FINAL
 UNLESS ALL SIGNATURES COMPLETED**

1/24/2020
 ENGINEERS & PLANNERS & SCIENTISTS & CONSTRUCTION MANAGERS LICENSE NUMBER: C-0784
KCI Associates
 of North Carolina, P.A.
 4005 Falls of House Road, Suite 400 Raleigh, NC 27609-6270 Phone: 919-785-5241

REVISIONS		SHEET NO.				
NO.	BY:	DATE:	NO.	BY:	DATE:	SHEET NO.
1			3			5-18
2			4			TOTAL SHEETS 29

KCI PROJ. #251801945.24