

### NOTES

STIRRUPS IN CAP MAY BE SHIFTED AS NECESSARY TO CLEAR DOWELS.

THE CONCRETE IN THE SHADED AREA OF THE WING SHALL BE POURED AFTER THE VERTICAL CONCRETE BARRIER RAIL IS CAST IF SLIP FORMING IS USED.

FOR PILE SPLICE DETAILS, SEE SHEET 4 OF 4.

FOR WING DETAILS, SEE SHEET 3 OF 4.

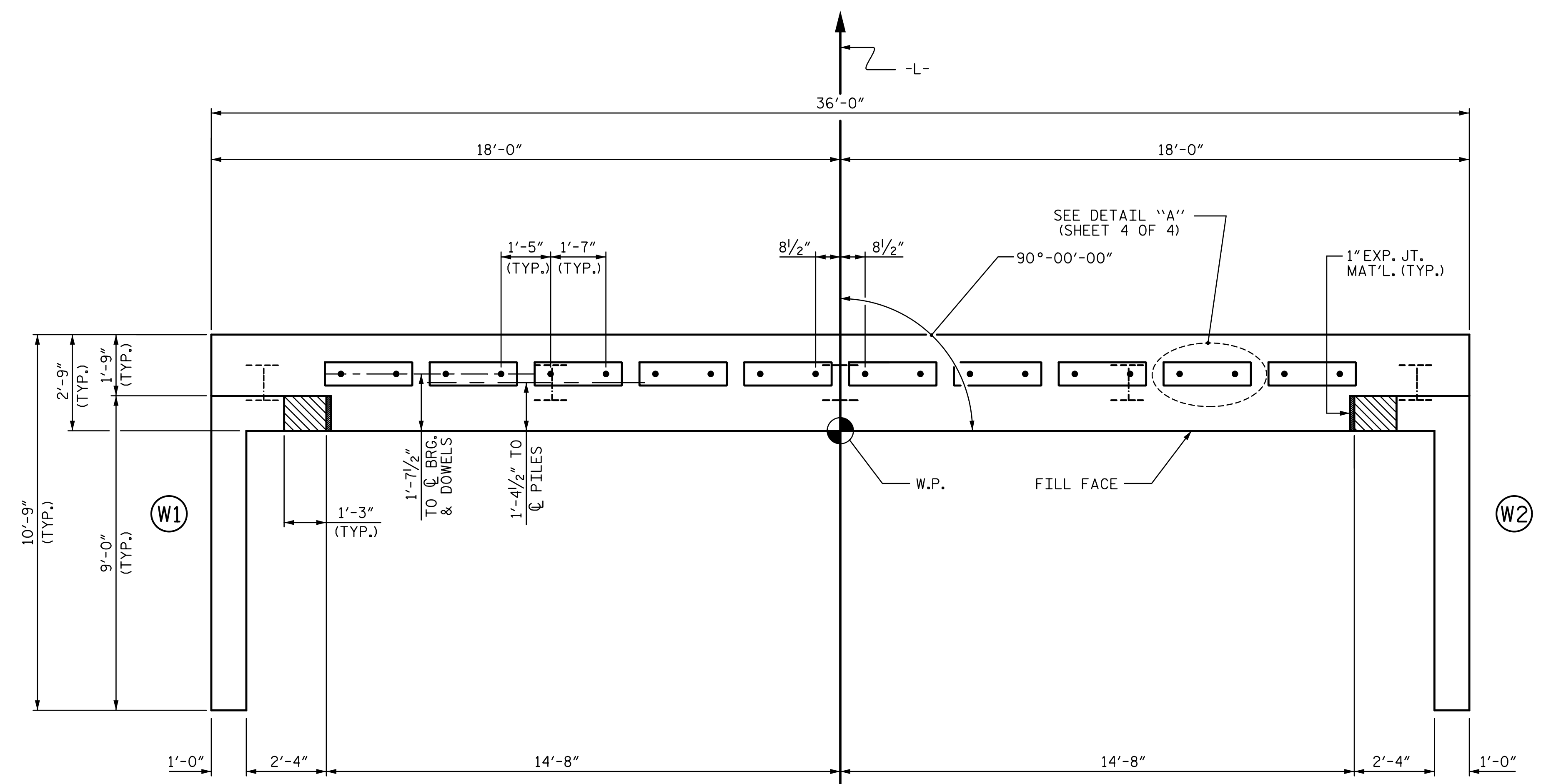

### PLAN

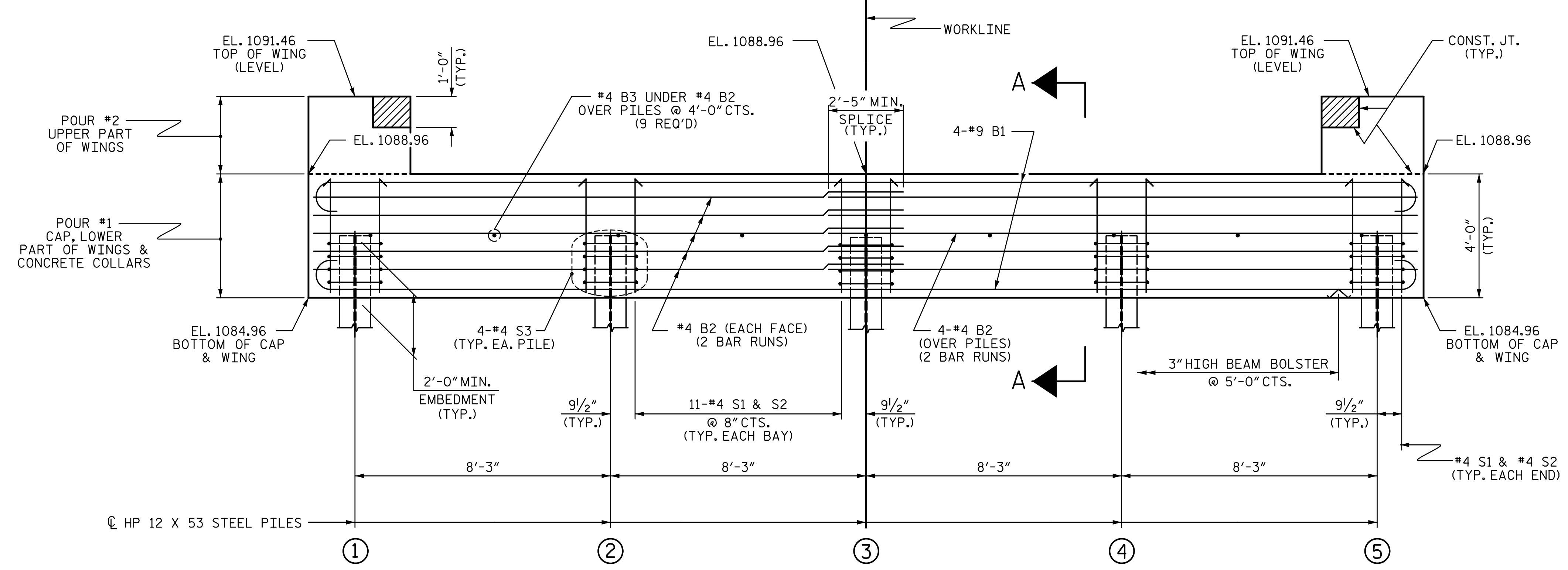

### ELEVATION

PROJECT NO. BR-0124  
WILKES COUNTY  
 STATION: 15+07.00 -L-  
 SHEET 1 OF 4

STATE OF NORTH CAROLINA  
 DEPARTMENT OF TRANSPORTATION  
 RALEIGH

SUBSTRUCTURE  
 END BENT No. 1

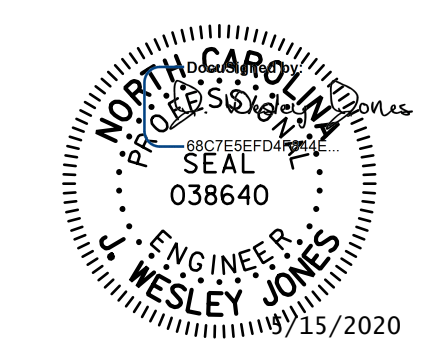

**STV** 100 YEARS  
 STV ENGINEERS, INC.  
 900 West Trade St., Suite 715  
 Charlotte, NC 28202  
 NC License Number F-0991

DOCUMENT NOT CONSIDERED  
 FINAL UNLESS ALL  
 SIGNATURES COMPLETED

REVISIONS					SHEET NO.
NO.	BY:	DATE:	NO.	BY:	DATE:
1			3		
2			4		

S-12  
 TOTAL SHEETS 21

R:\Structures\ustation\Finals\401\_023\_BR-0124\_SML\_EL\_02\_960166.dgn 4/14/2020 2:41:49 PM Jones

DRAWN BY : WAW	DATE : 10-19
CHECKED BY : JWJ	DATE : 12-19
DESIGN ENGINEER OF RECORD : JWJ	DATE : 4-20
DRAWN BY : WJH 12/11	REV. 4/15
CHECKED BY : AAC 12/11	MAA/TMG

WINGS NOT SHOWN FOR CLARITY.  
 FOR SECTION A-A, SEE SHEET 4 OF 4.  
 CONCRETE COLLARS FOR STEEL PILES NOT SHOWN IN PLAN AND ELEVATION VIEWS FOR CLARITY.  
 SEE "CORROSION PROTECTION FOR STEEL PILES DETAIL", SHEET 4 OF 4.