

NOTES

STIRRUPS IN CAP MAY BE SHIFTED AS NECESSARY TO CLEAR DOWELS.

THE CONCRETE IN THE SHADED AREA OF THE WING SHALL BE POURED AFTER THE VERTICAL CONCRETE BARRIER RAIL IS CAST IF SLIP FORMING IS USED.

FOR PILE SPLICE DETAILS, SEE SHEET 4 OF 4.

FOR WING DETAILS, SEE SHEET 3 OF 4.

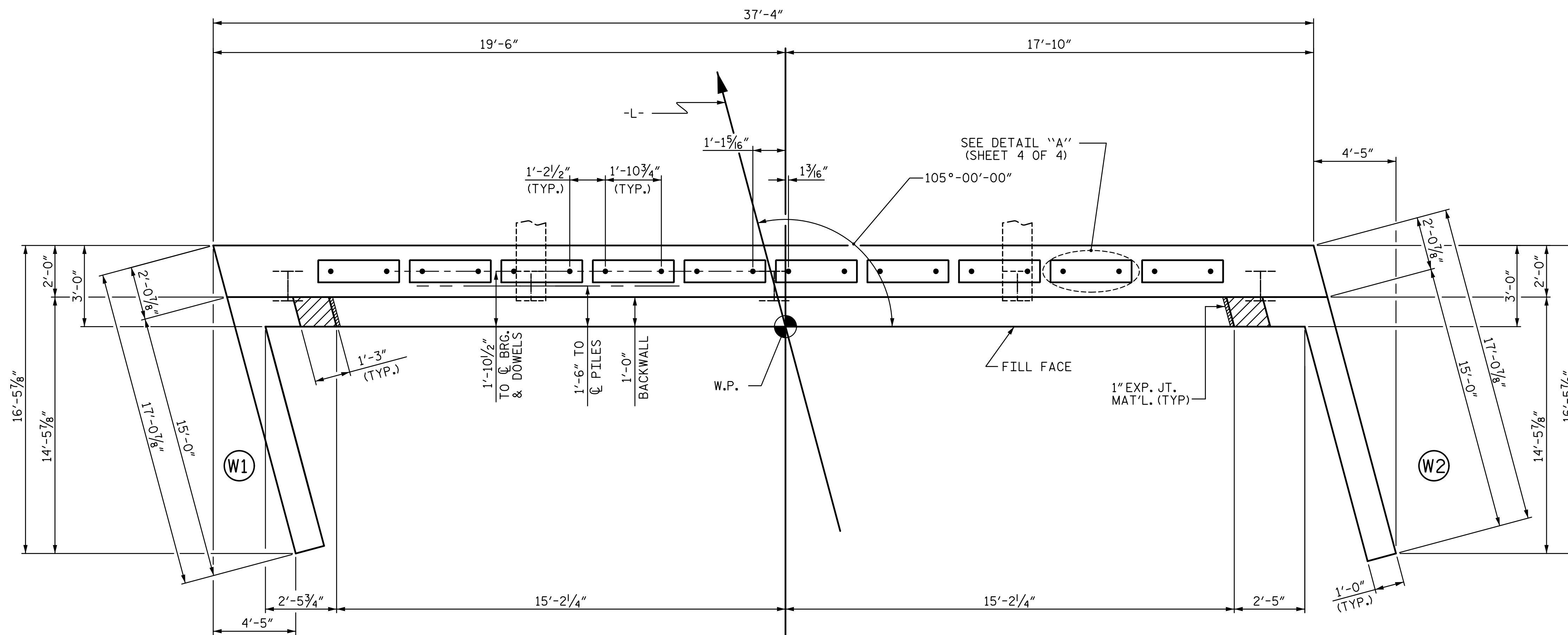

PLAN

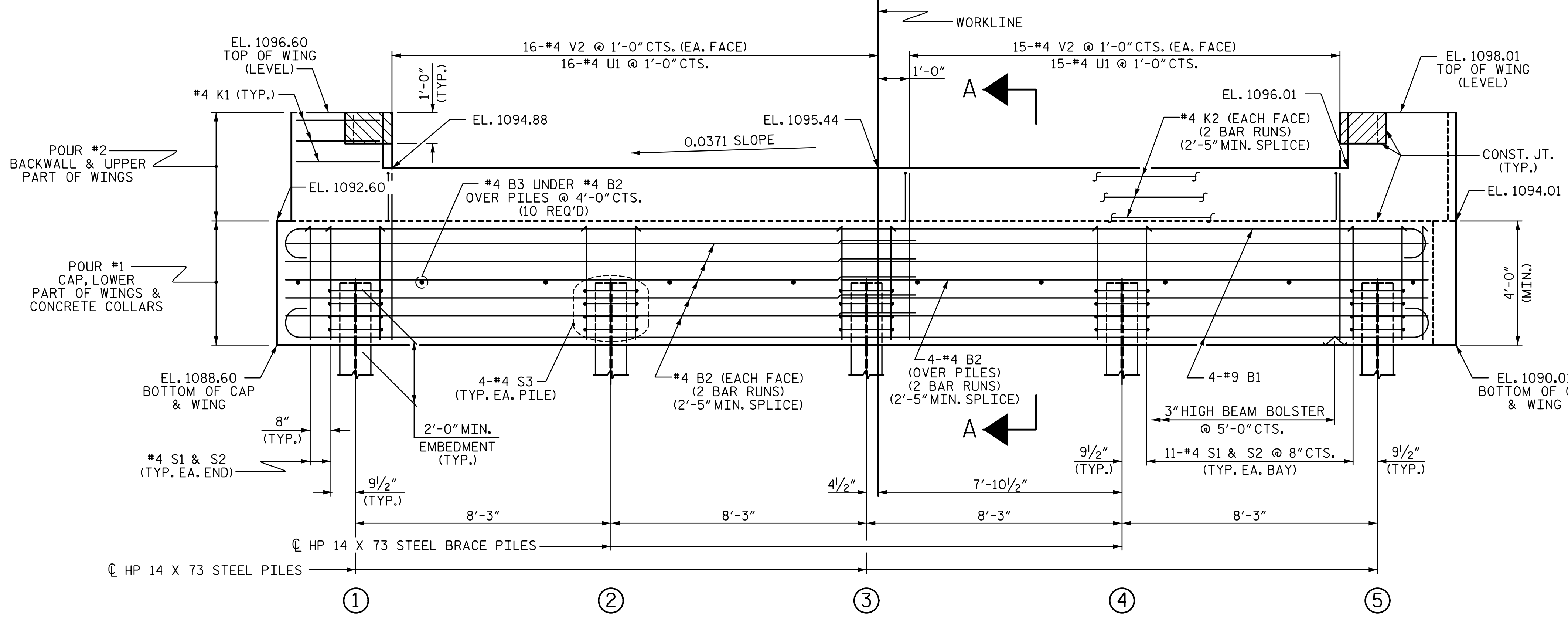

ELEVATION

TOP OF PILE ELEVATIONS	
①	1090.72
②	1091.02
③	1091.33
④	1091.63
⑤	1091.94

PROJECT NO. BR-0114
IREDELL COUNTY
 STATION: 16+08.00 -L-
 SHEET 1 OF 4

STATE OF NORTH CAROLINA
 DEPARTMENT OF TRANSPORTATION
 RALEIGH

SUBSTRUCTURE
 END BENT No. 1

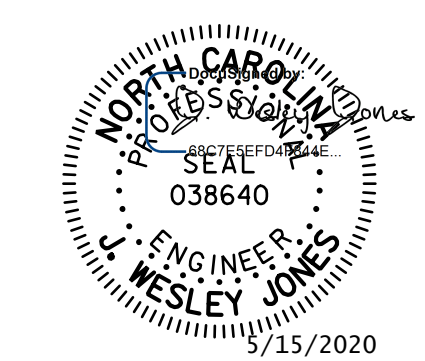

STV 100 YEARS
 STV ENGINEERS, INC.
 900 West Trade St., Suite 715
 Charlotte, NC 28202
 NC License Number F-0991

DOCUMENT NOT CONSIDERED
 FINAL UNLESS ALL
 SIGNATURES COMPLETED

REVISIONS				SHEET NO.	
NO.	BY:	DATE:	NO.	BY:	DATE:
1			3		
2			4		

S-10
 TOTAL SHEETS 15

R:\Structures\ustation\Finals\4019_BR-0114_SMJ_EL.010_480165.dgn
 4:37:21 PM
 3/11/2020

DRAWN BY : WAW DATE : 10-19
 CHECKED BY : JWJ DATE : 12-19
 DESIGN ENGINEER OF RECORD : JWJ DATE : 3-20

WINGS NOT SHOWN FOR CLARITY.
 FOR SECTION A-A, SEE SHEET 4 OF 4.
 CONCRETE COLLARS FOR STEEL PILES NOT SHOWN IN PLAN AND ELEVATION VIEWS FOR CLARITY.
 SEE "CORROSION PROTECTION FOR STEEL PILES DETAIL", SHEET 4 OF 4.