

### NOTES

- STIRRUPS IN CAP MAY BE SHIFTED AS NECESSARY TO CLEAR DOWELS.
- ★ INVERT ALTERNATE STIRRUPS.
- GALVANIZE THE TOP OF EACH INTERIOR BENT PILE A MINIMUM OF 25 FEET. GALVANIZE IN ACCORDANCE WITH SECTION 1076 OF THE STANDARD SPECIFICATIONS.

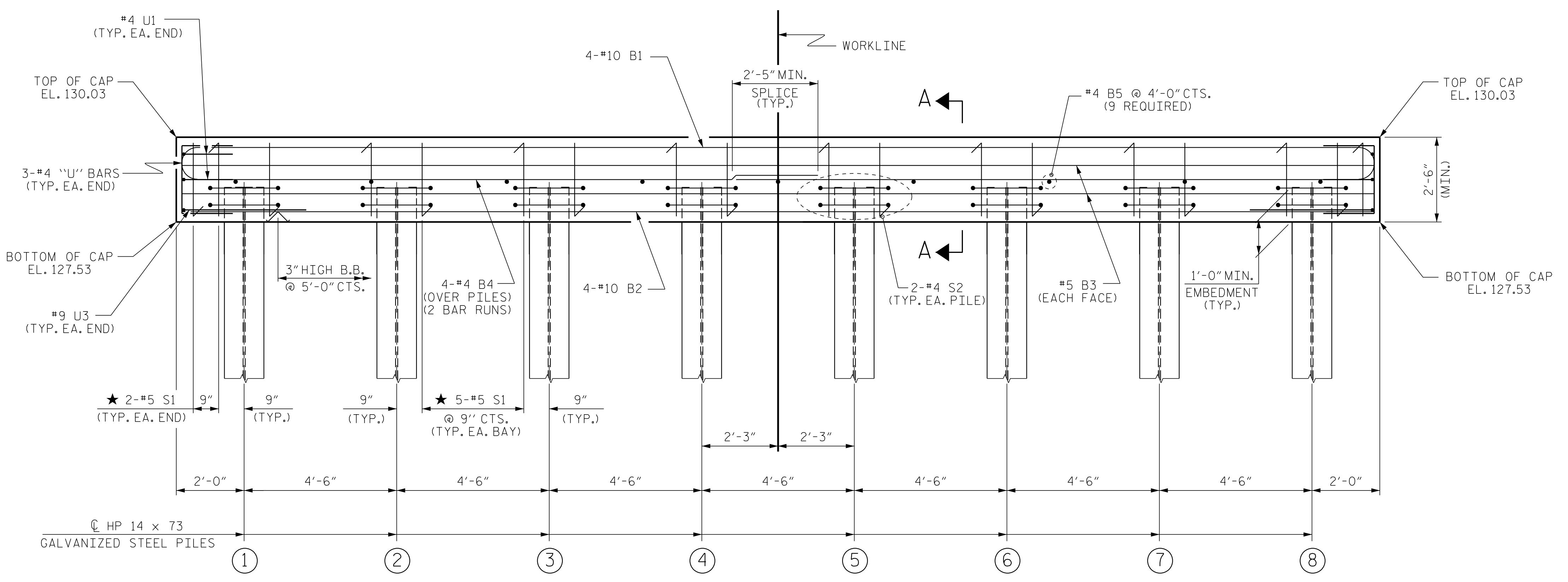

PROJECT NO. BR-0121  
 SAMPSON COUNTY  
 STATION: 15+46.50 -L-  
 SHEET 1 OF 2

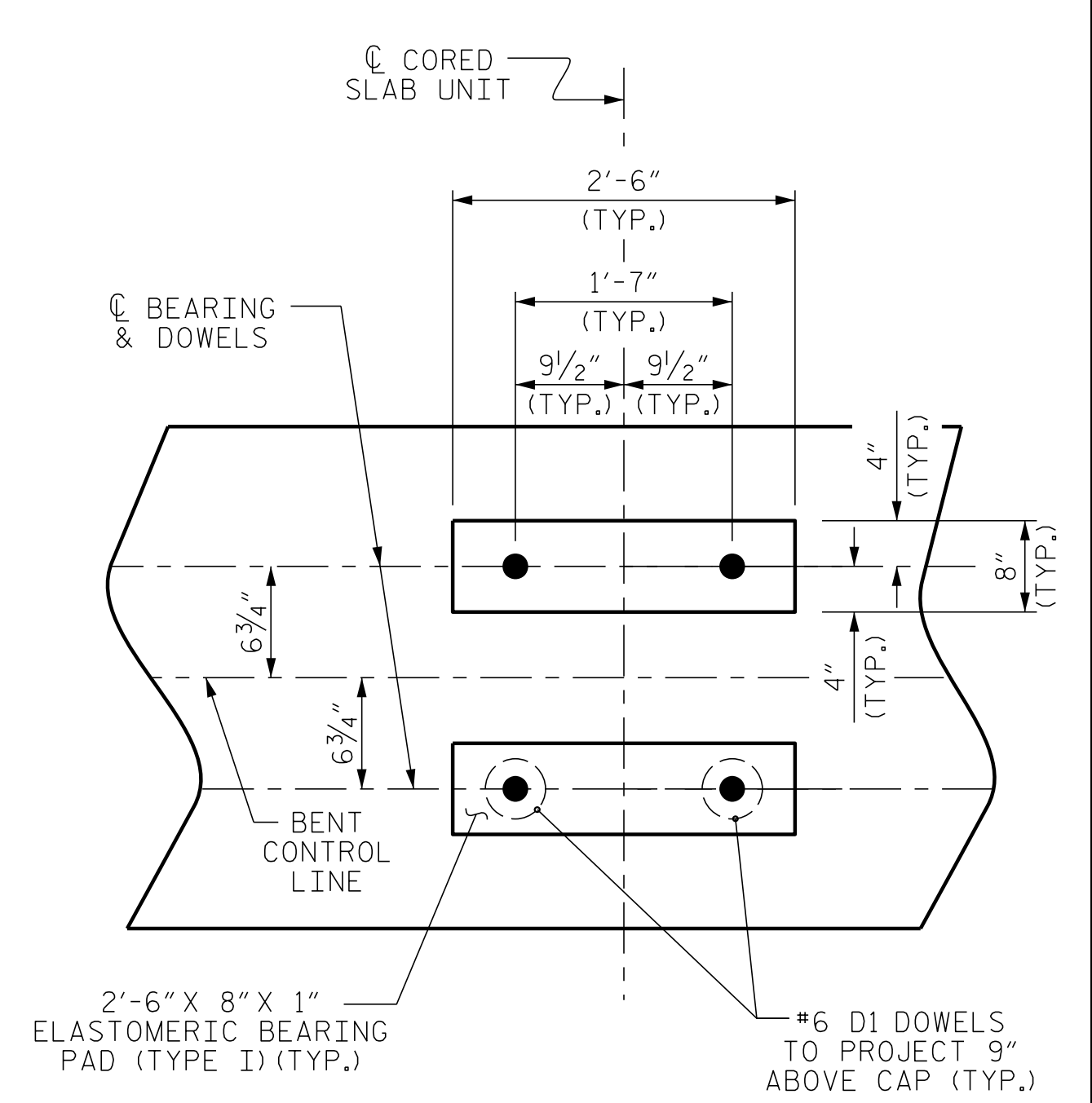
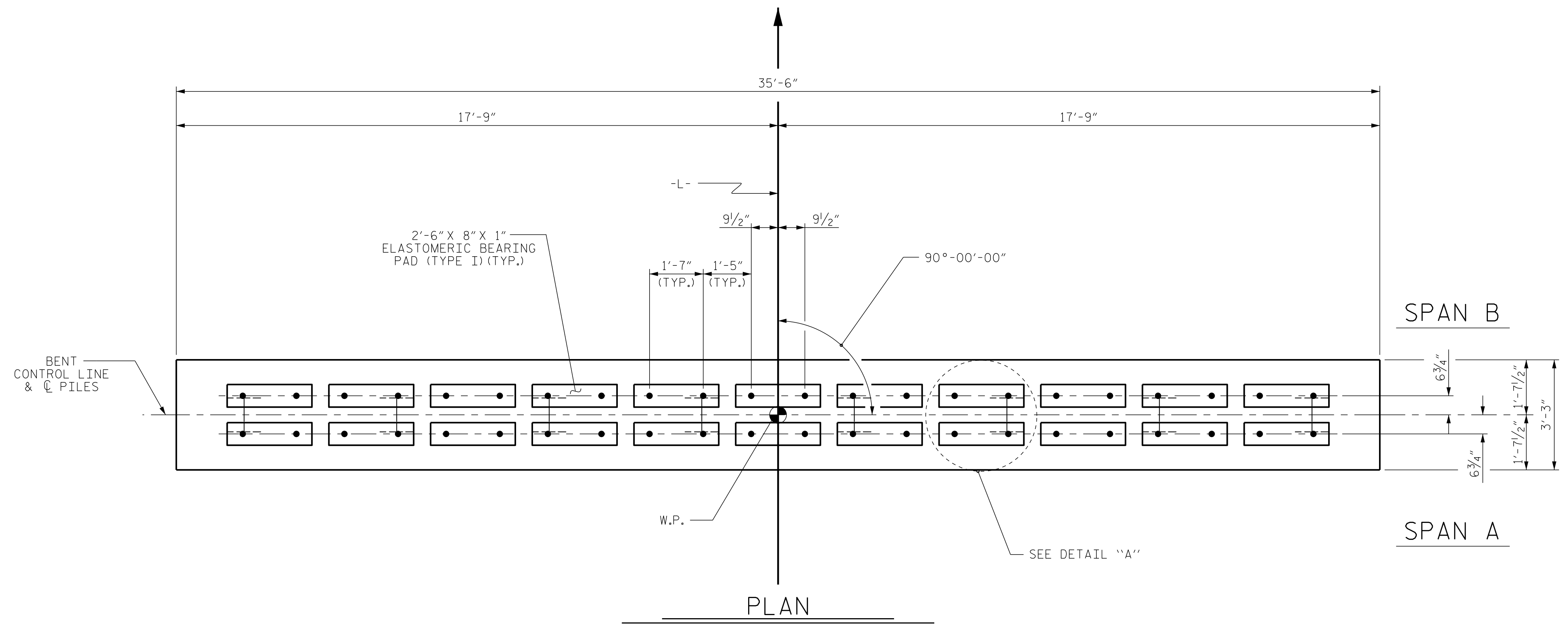
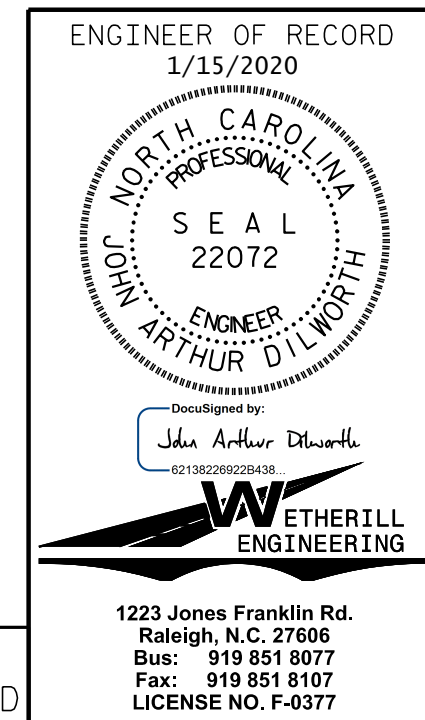

STATE OF NORTH CAROLINA DEPARTMENT OF TRANSPORTATION RALEIGH					
SUBSTRUCTURE BENT No. 1					
REVISIONS					
NO.	BY:	DATE:	NO.	BY:	DATE:
1			3		
2			4		
SHEET NO. S-15					TOTAL SHEETS 18

DOCUMENT NOT CONSIDERED FINAL  
 UNLESS ALL SIGNATURES COMPLETED

P:\2019\19108\01\_BR-0121\Structures\DCM\BR0121\_SMU\_BT.dgn  
 8/28/2019 8:32:45 AM

ASSEMBLED BY : J. PENDERGRAFT	DATE : 2-19
CHECKED BY : J. DILWORTH	DATE : 4-19
DRAWN BY : DGE 05/10	REV. 6/17 MAA/THC
CHECKED BY : MKT 05/10	