

NOTES

STIRRUPS IN CAP MAY BE SHIFTED AS NECESSARY TO CLEAR DOWELS.

THE CONCRETE IN THE SHADED AREA OF THE WING SHALL BE POURED AFTER THE VERTICAL CONCRETE BARRIER RAIL IS CAST IF SLIP FORMING IS USED.

FOR PILE SPlice DETAILS, SEE SHEET 4 OF 4.

FOR WING DETAILS, SEE SHEET 3 OF 4.

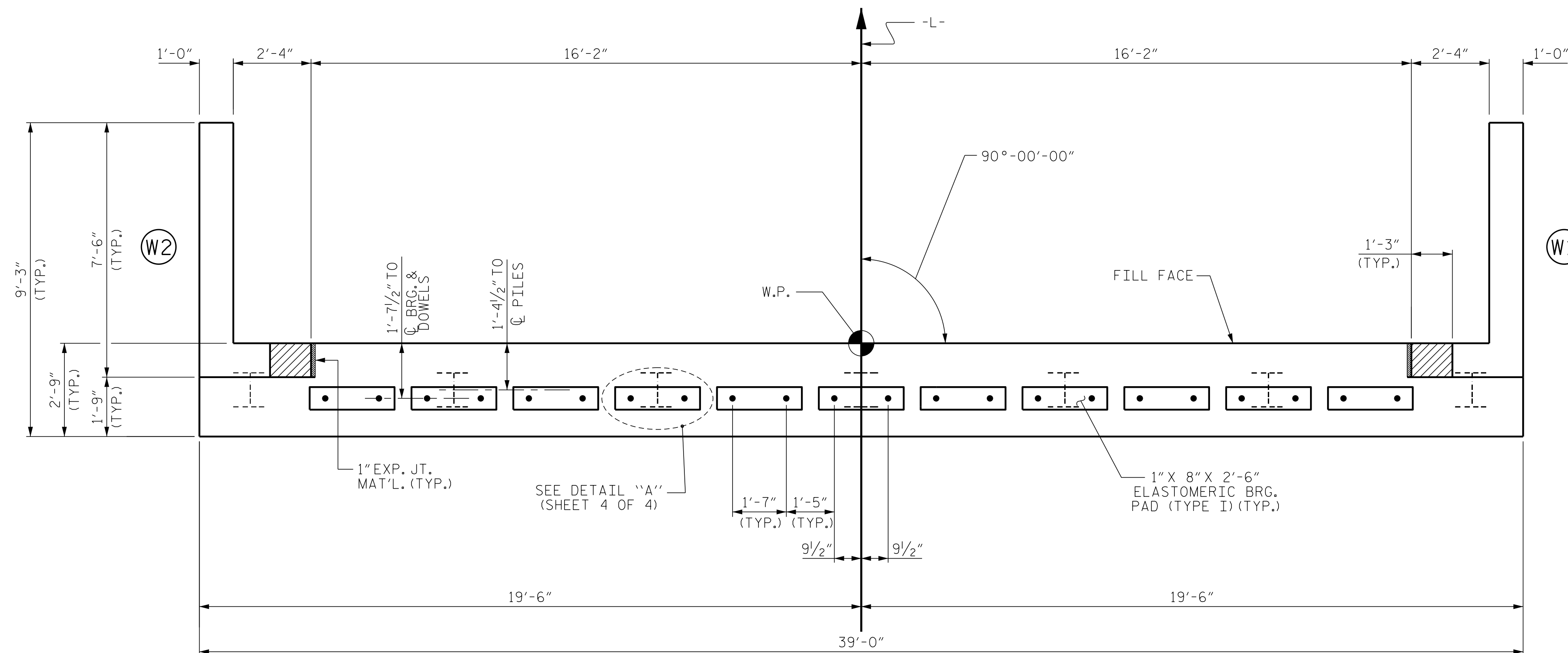

PLAN

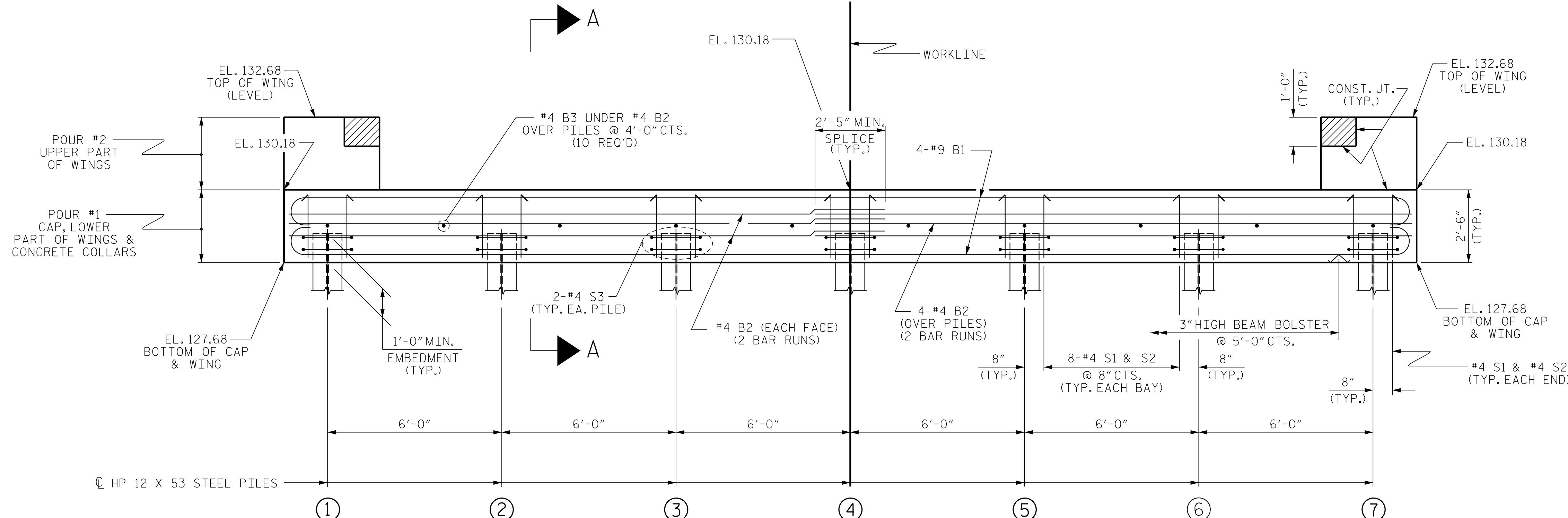

ELEVATION

WINGS NOT SHOWN FOR CLARITY.
 FOR SECTION A-A, SEE SHEET 4 OF 4.
 CONCRETE COLLARS FOR STEEL PILES NOT SHOWN IN PLAN AND ELEVATION VIEWS FOR CLARITY.
 SEE "CORROSION PROTECTION FOR STEEL PILES DETAIL", SHEET 4 OF 4.

PROJECT NO. BR-0121
 SAMPSON COUNTY
 STATION: 15+46.50 -L-

SHEET 2 OF 4

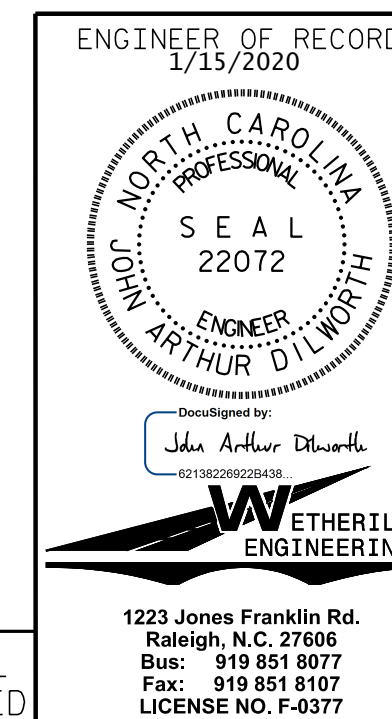

STATE OF NORTH CAROLINA
 DEPARTMENT OF TRANSPORTATION
 RALEIGH

SUBSTRUCTURE
 END BENT No. 2

REVISIONS

NO.	BY:	DATE:	NO.	BY:	DATE:
1			3		
2			4		

SHEET NO.
 S-12
 TOTAL SHEETS
 18

ASSEMBLED BY : J. PENDERGRAFT	DATE : 2-19
CHECKED BY : J. DILWORTH	DATE : 4-19
DRAWN BY : DGE	01/10
CHECKED BY : MKT	01/10
REV. 4/15	MAA/TMG

DOCUMENT NOT CONSIDERED FINAL
 UNLESS ALL SIGNATURES COMPLETED

1223 Jones Franklin Rd.
 Raleigh, N.C. 27606
 Bus: 919 851 8077
 Fax: 919 851 8107
 LICENSE NO. F-0377

STD. NO. EB-33-90S