

NOTES

STIRRUPS IN CAP MAY BE SHIFTED AS NECESSARY TO CLEAR DOWELS.

THE CONCRETE IN THE SHADED AREA OF THE WING SHALL BE POURED AFTER THE VERTICAL CONCRETE BARRIER RAIL IS CAST IF SLIP FORMING IS USED.

FOR PILE SPLICE DETAILS, SEE SHEET 4 OF 4.

FOR WING DETAILS, SEE SHEET 3 OF 4.

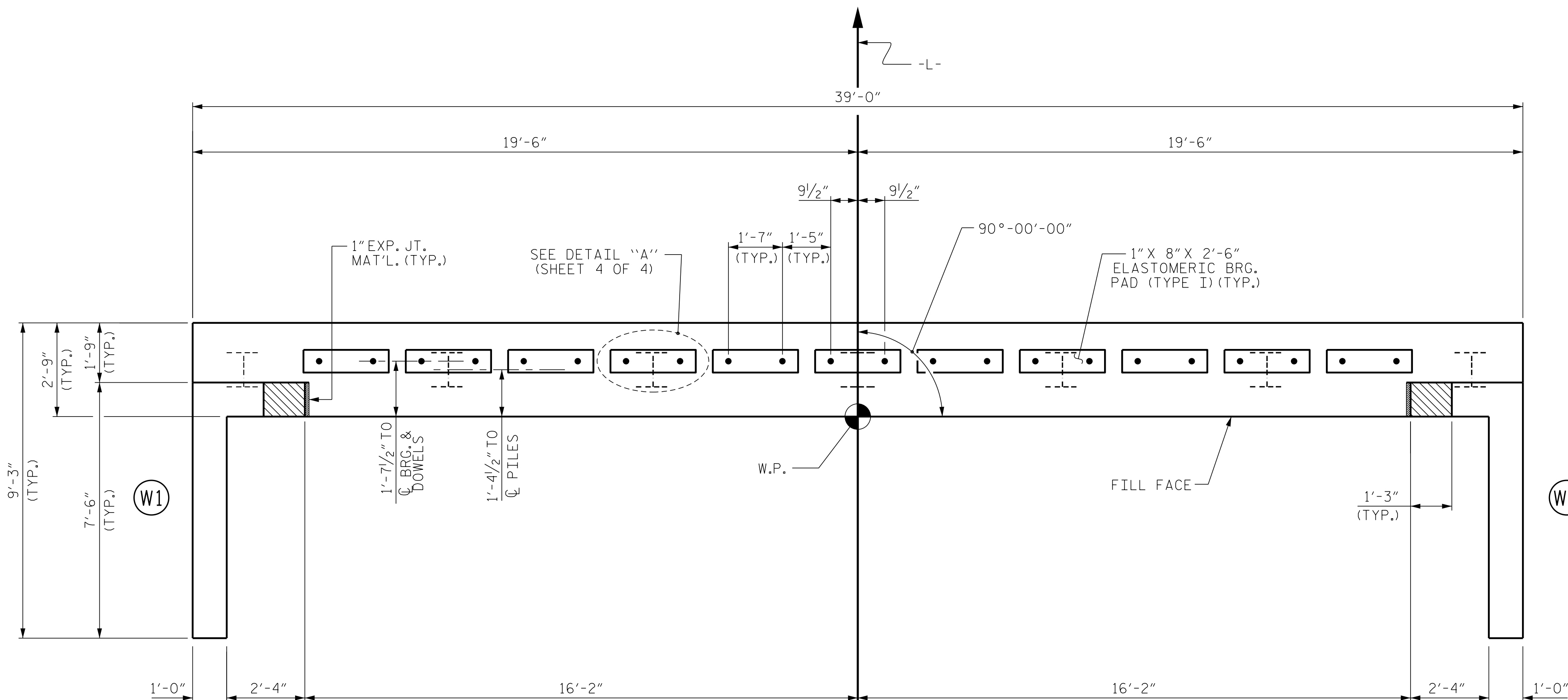

PLAN

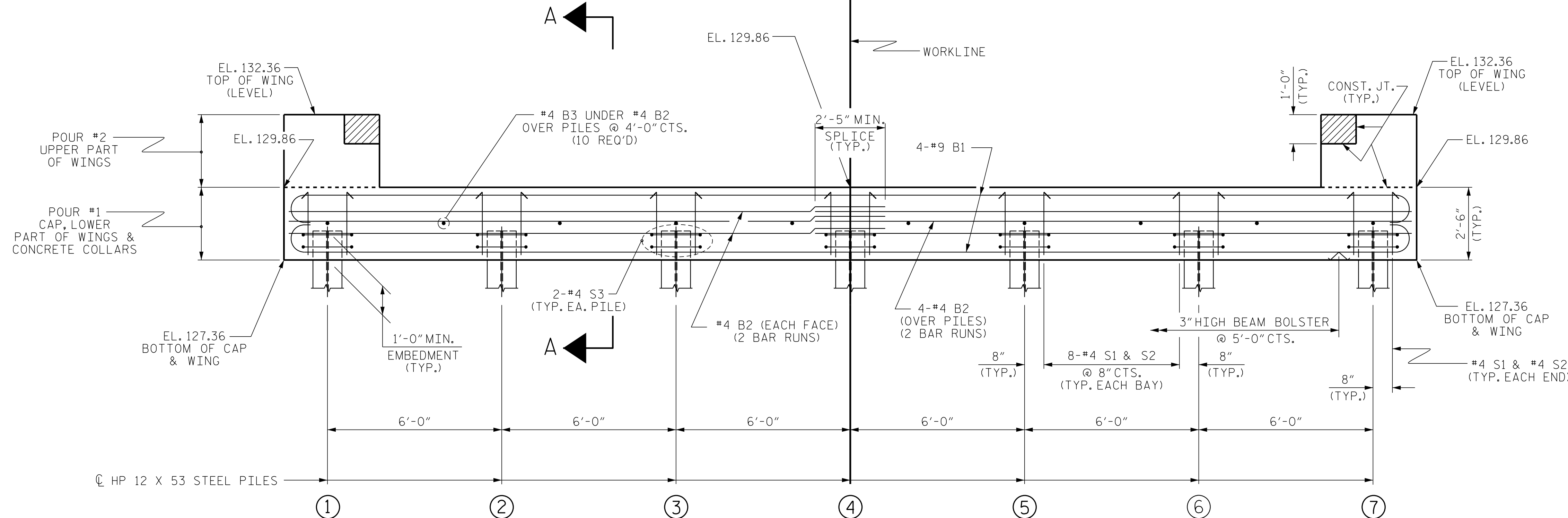

ELEVATION

WINGS NOT SHOWN FOR CLARITY.  
FOR SECTION A-A, SEE SHEET 4 OF 4.  
CONCRETE COLLARS FOR STEEL PILES NOT SHOWN IN PLAN AND ELEVATION VIEWS FOR CLARITY.  
SEE "CORROSION PROTECTION FOR STEEL PILES DETAIL", SHEET 4 OF 4.

PROJECT NO. BR-0121  
SAMPSON COUNTY  
STATION: 15+46.50 -L-

SHEET 1 OF 4

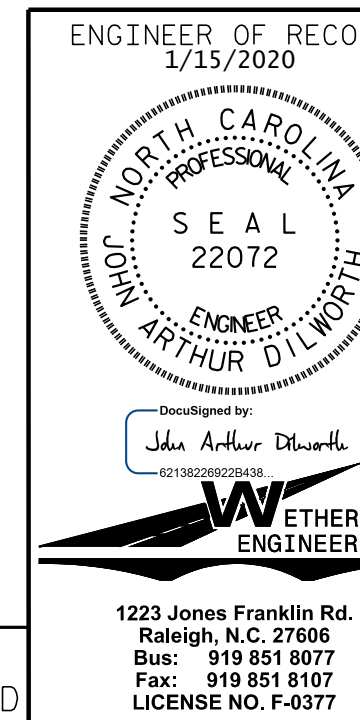

STATE OF NORTH CAROLINA  
DEPARTMENT OF TRANSPORTATION  
RALEIGH

SUBSTRUCTURE  
END BENT No. 1

REVISIONS

NO.	BY:	DATE:	NO.	BY:	DATE:
1			3		
2			4		

SHEET NO.  
S-11  
TOTAL SHEETS  
18

DOCUMENT NOT CONSIDERED FINAL  
UNLESS ALL SIGNATURES COMPLETED

1223 Jones Franklin Rd.  
Raleigh, N.C. 27606  
Bus: 919 851 8077  
Fax: 919 851 8107  
LICENSE NO. F-0377

STD. NO. EB-33-90S

P:\2019\108.01\_BR-0121\Structures\DNBRO12\_LSMU\_EB.dgn 8/28/2019 8:13:38 AM

ASSEMBLED BY : J. PENDERGRAFT	DATE : 2-19
CHECKED BY : J. DILWORTH	DATE : 4-19
DRAWN BY : DGE	01/10
CHECKED BY : MKT	01/10
REV. 4/15	MAA/TMG