

P:\2019\19108\01\_BR-0121\Structures\DNB\BR0121\_SMU\_PS.dgn  
 8/28/2019 8:01:56 AM

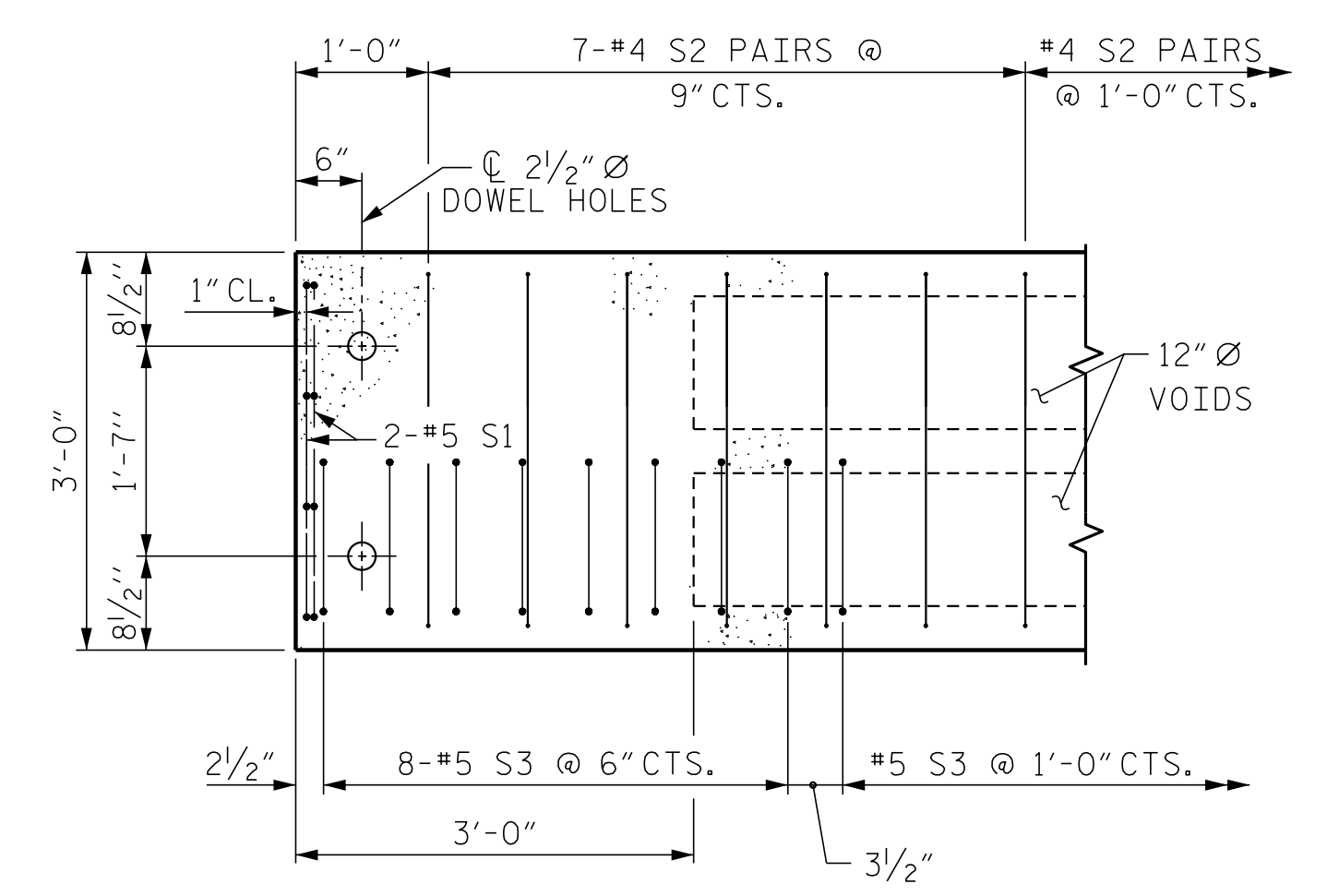

**DETAIL "A"**  
 (TYPICAL EACH END OF UNIT)  
 NOTE: EXTERIOR UNIT SHOWN - INTERIOR UNIT SIMILAR EXCEPT OMIT #5 S3 BARS.

PROJECT NO. BR-0121  
SAMPSON COUNTY  
 STATION: 15+46.50 -L-  
 SHEET 2 OF 5

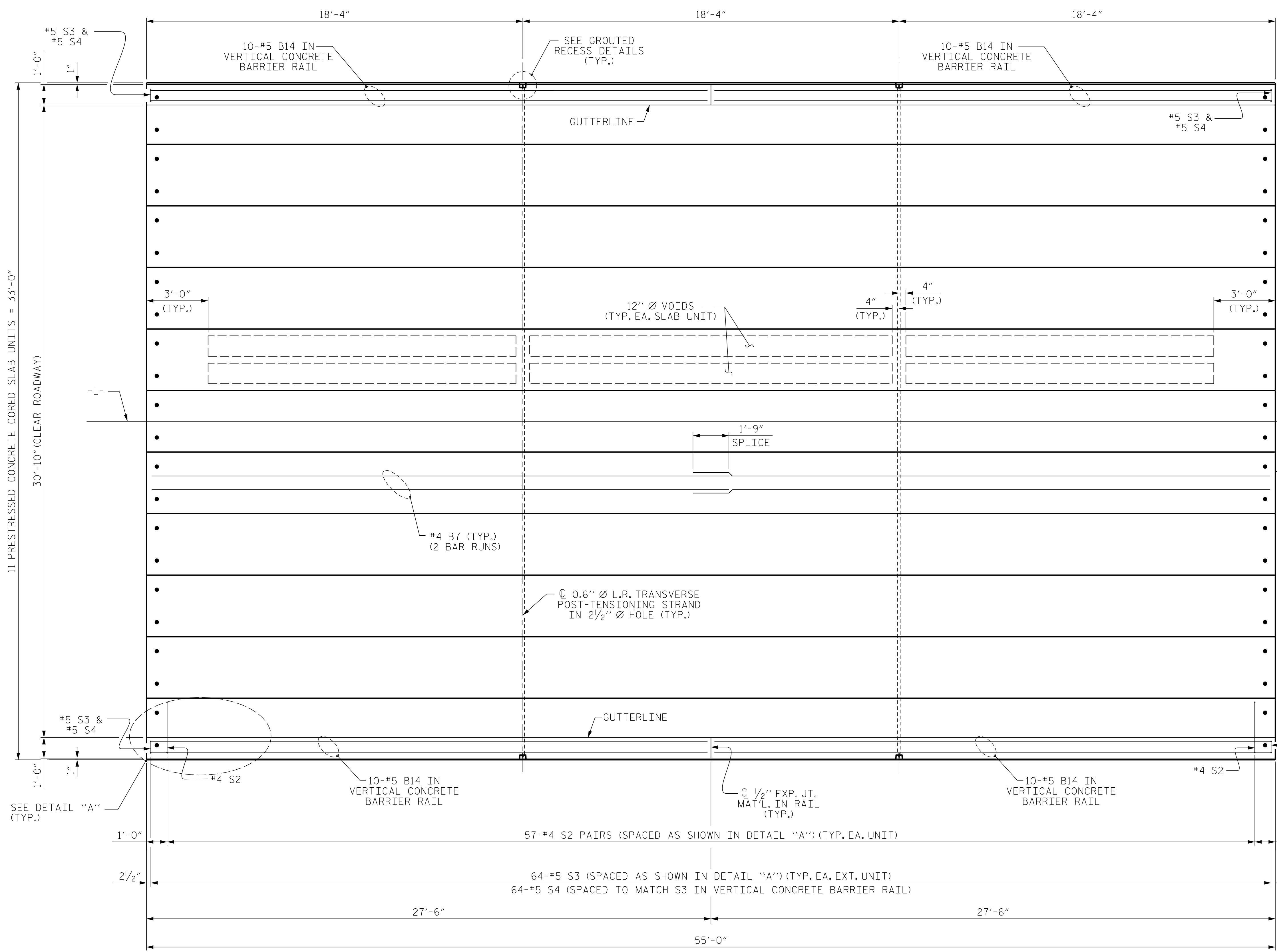
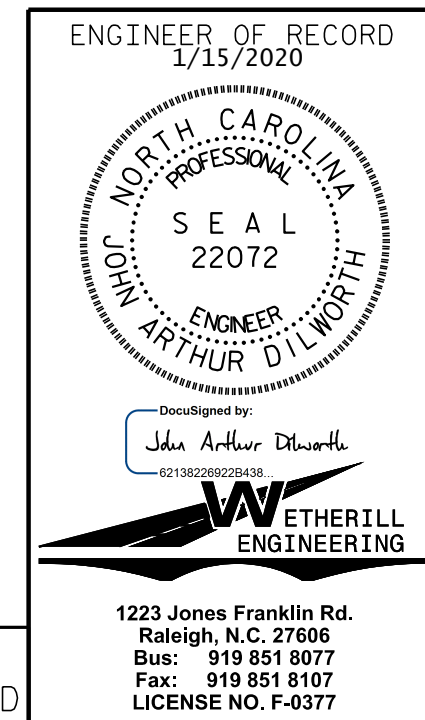

STATE OF NORTH CAROLINA DEPARTMENT OF TRANSPORTATION RALEIGH					
PLAN OF 55' UNIT 30'-10" CLEAR ROADWAY 90° SKEW SPAN A					
REVISIONS					
NO.	BY:	DATE:	NO.	BY:	DATE:
1			3		
2			4		
					SHEET NO. S-6
					TOTAL SHEETS 18

ASSEMBLED BY : J. PENDERGRAFT	DATE : 2-19
CHECKED BY : J. DILWORTH	DATE : 4-19
DRAWN BY : DCE 3/09	REV. 12/5/11 MAA/AAC
CHECKED BY : BCH 3/09	REV. 8/14 MAA/TMG

DOCUMENT NOT CONSIDERED FINAL  
 UNLESS ALL SIGNATURES COMPLETED

**PLAN OF UNIT**

STD. NO. 21" PCS\_33\_90S\_55L