

NOTES

STIRRUPS IN CAP MAY BE SHIFTED AS NECESSARY TO CLEAR DOWELS.

★ INVERT ALTERNATE STIRRUPS.

GALVANIZE THE TOP OF EACH INTERIOR BENT PILE A MINIMUM OF 24 FEET. GALVANIZE IN ACCORDANCE WITH SECTION 1076 OF THE STANDARD SPECIFICATIONS.

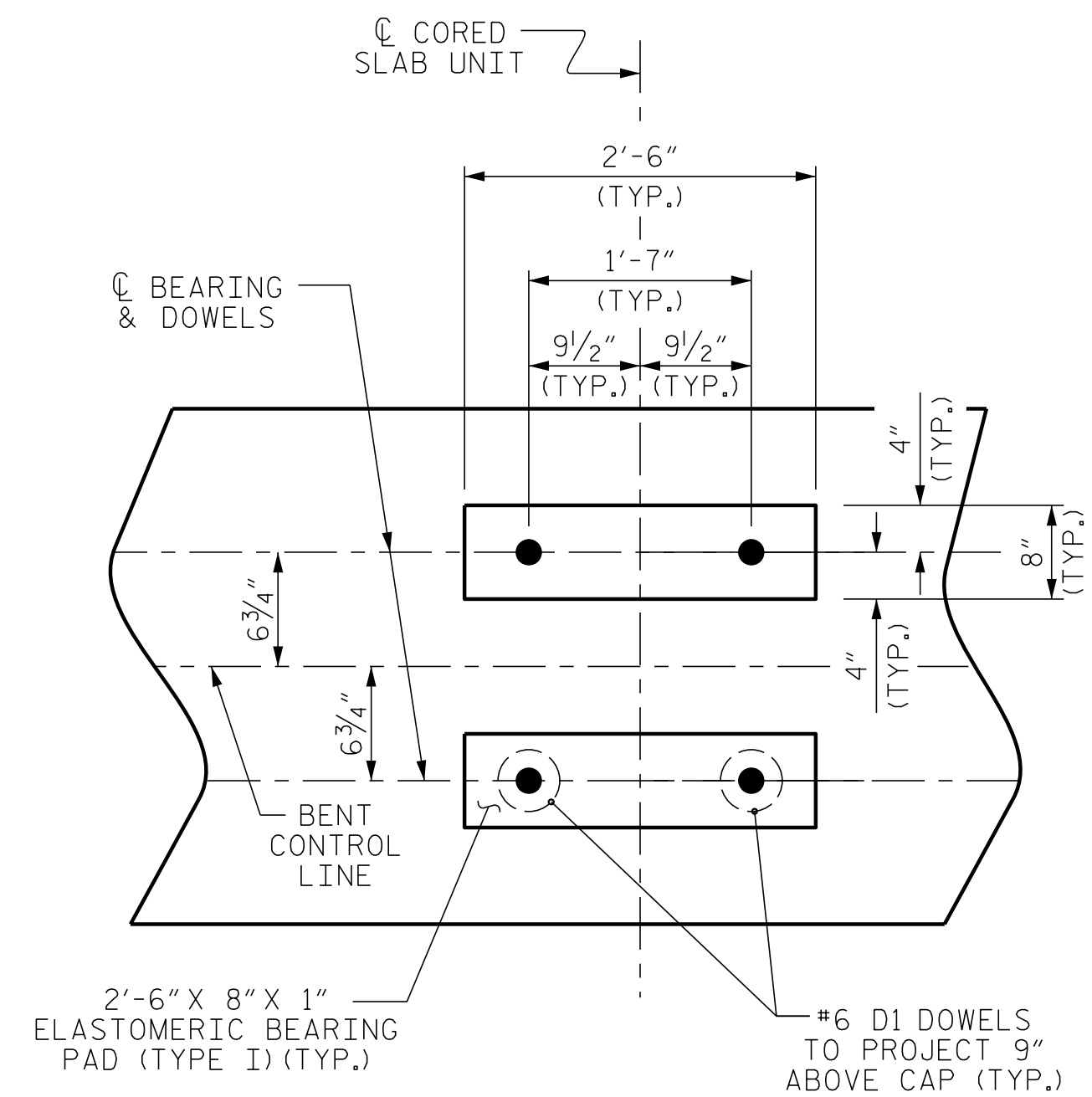
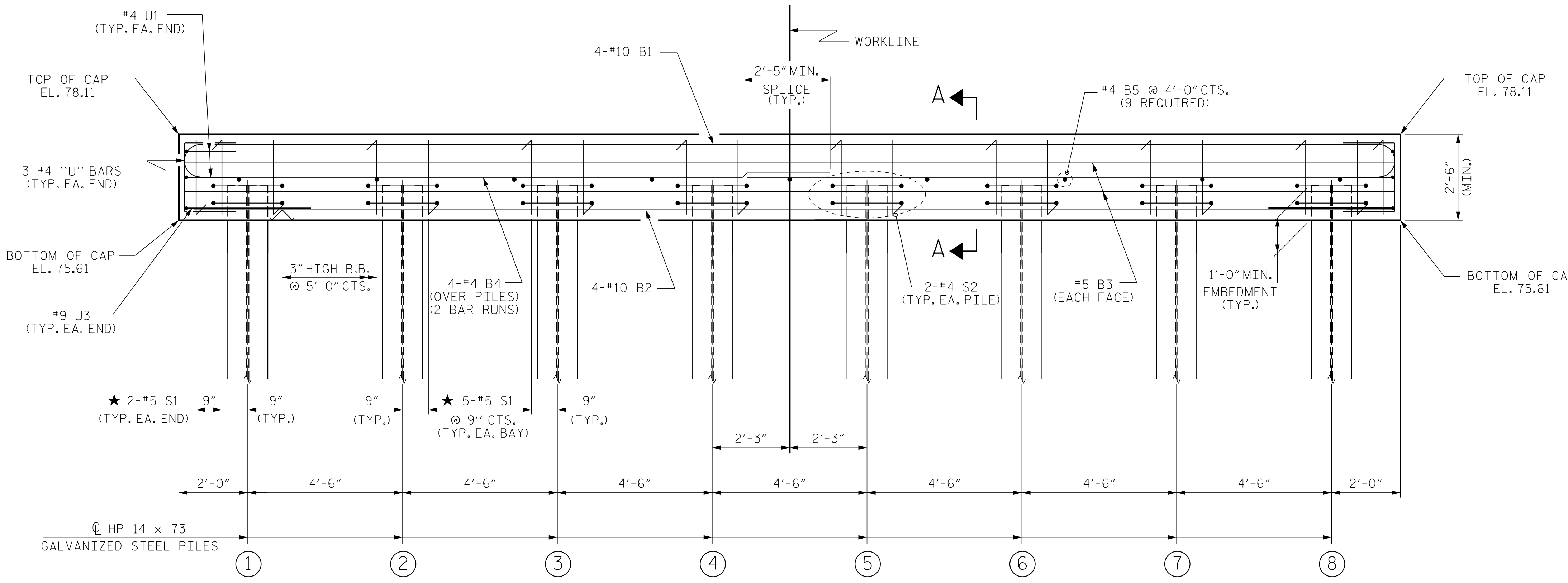
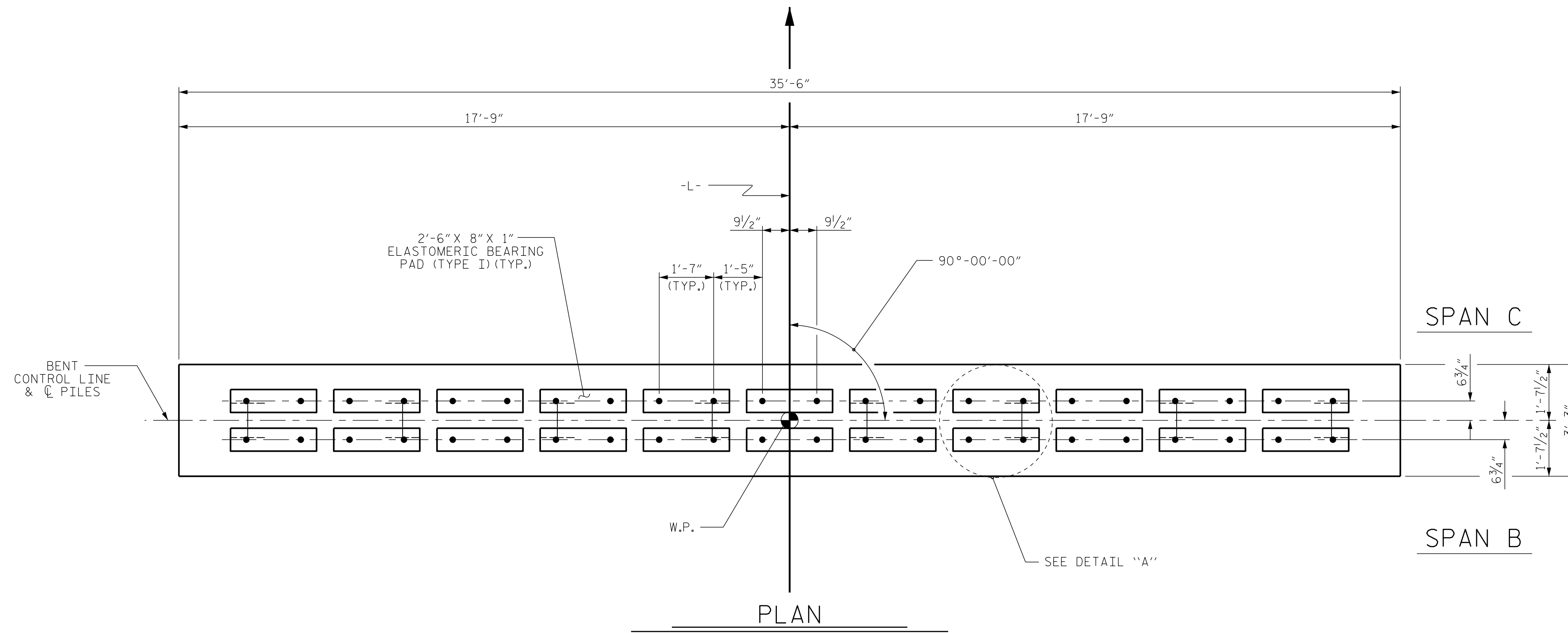

DETAIL "A"

(DIMENSIONS ARE TYPICAL EACH BEARING)

PROJECT NO. BR-0111
 EDGEcombe COUNTY
 STATION: 35+90.50 -L-

SHEET 1 OF 2

ELEVATION

FOR SECTION A-A, SEE SHEET 2 OF 2

P:\2019\1910401 BR-0111\Structures\DNBR\IDG 3\BR0111_BR#3_STR_BT.dgn
 12/19/2019 2:36:39 PM

ASSEMBLED BY : J. PENDERGRAFT	DATE : 6-19
CHECKED BY : J. DILWORTH	DATE : 8-19
DRAWN BY : DGE 05/10	REV. 6/17
CHECKED BY : MKT 05/10	MAA/THC

DOCUMENT NOT CONSIDERED FINAL
 UNLESS ALL SIGNATURES COMPLETED

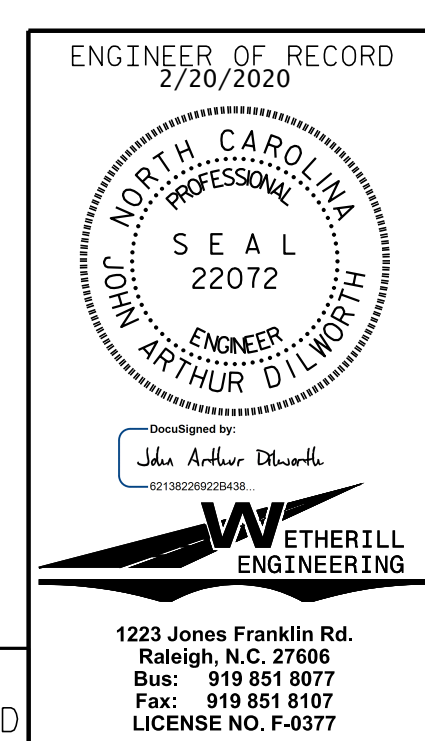

STATE OF NORTH CAROLINA DEPARTMENT OF TRANSPORTATION RALEIGH					
SUBSTRUCTURE BENT No. 2					
REVISIONS					
NO.	BY:	DATE:	NO.	BY:	DATE:
1			3		
2			4		
SHEET NO. S03-14					TOTAL SHEETS 17