

NOTES

STIRRUPS IN CAP MAY BE SHIFTED AS NECESSARY TO CLEAR DOWELS.

THE CONCRETE IN THE SHADED AREA OF THE WING SHALL BE POURED AFTER THE VERTICAL CONCRETE BARRIER RAIL IS CAST IF SLIP FORMING IS USED.

FOR PILE SPLICE DETAILS, SEE SHEET 4 OF 4.

FOR WING DETAILS, SEE SHEET 3 OF 4.

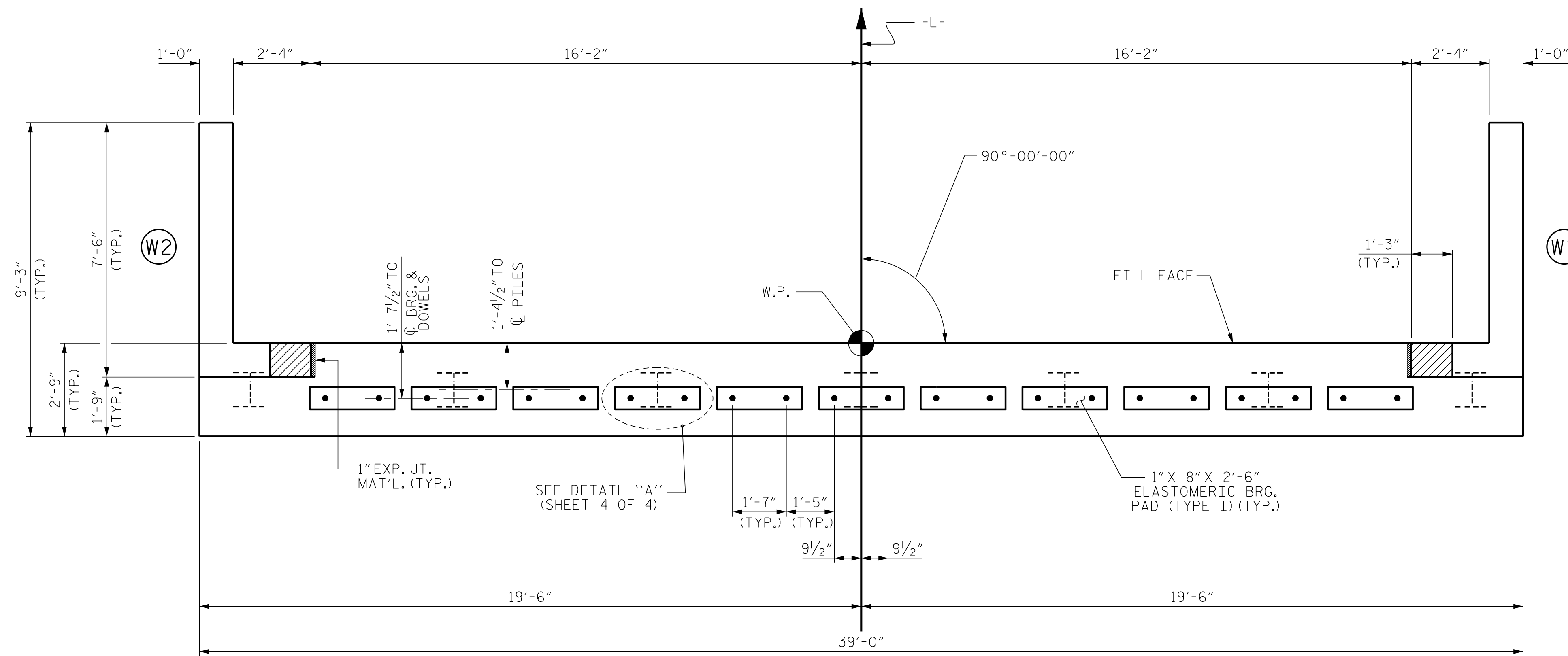

PLAN

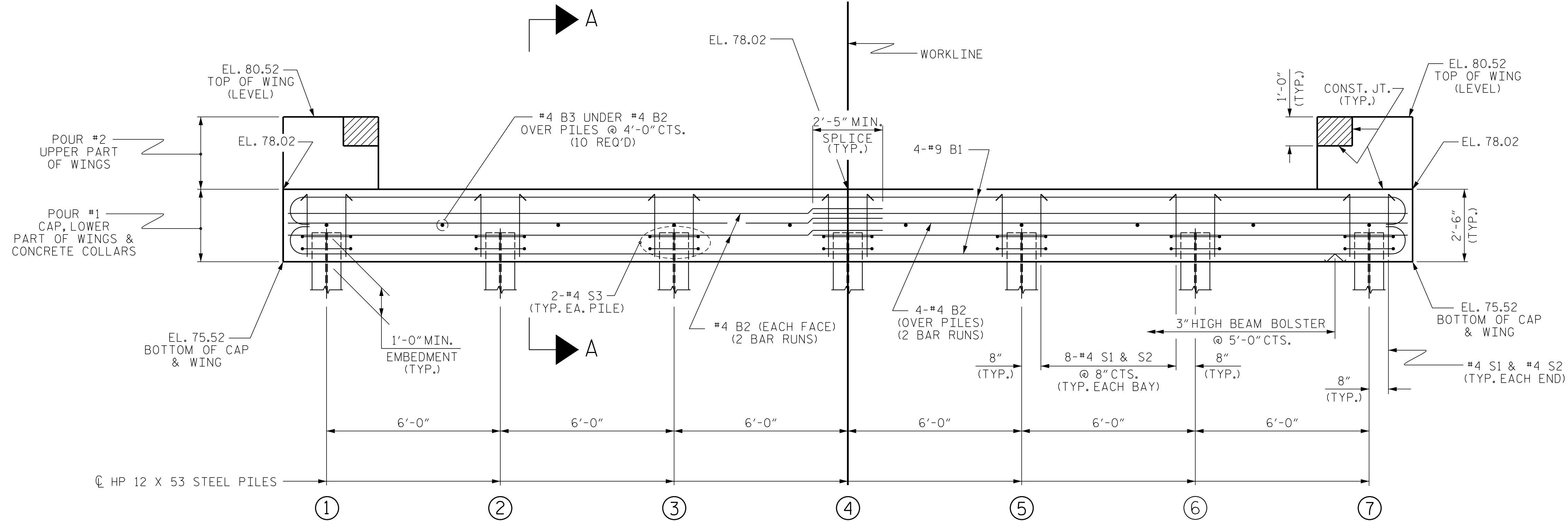

ELEVATION

WINGS NOT SHOWN FOR CLARITY.  
FOR SECTION A-A, SEE SHEET 4 OF 4.  
CONCRETE COLLARS FOR STEEL PILES NOT SHOWN IN PLAN AND ELEVATION VIEWS FOR CLARITY.  
SEE "CORROSION PROTECTION FOR STEEL PILES DETAIL", SHEET 4 OF 4.

PROJECT NO. BR-0111  
EDGEcombe COUNTY  
STATION: 35+90.50 -L-

SHEET 2 OF 4

STATE OF NORTH CAROLINA  
DEPARTMENT OF TRANSPORTATION  
RALEIGH

SUBSTRUCTURE  
END BENT No. 2

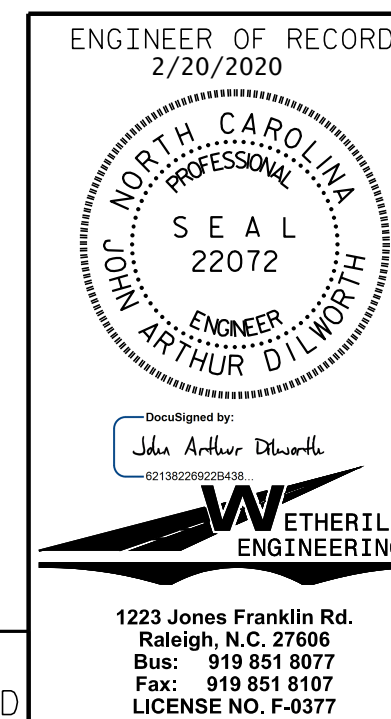

REVISIONS						SHEET NO.
NO.	BY:	DATE:	NO.	BY:	DATE:	S03-9
1			3			TOTAL SHEETS 17
2			4			

DOCUMENT NOT CONSIDERED FINAL  
UNLESS ALL SIGNATURES COMPLETED

ASSEMBLED BY : J. PENDERGRAFT	DATE : 6-19
CHECKED BY : J. DILWORTH	DATE : 8-19
DRAWN BY : DGE	01/10
CHECKED BY : MKT	01/10
REV. 4/15	MAA/TMG

P:\2019\1910401 BR-0111\Structures\DNBR\IDG 3\BR0111\_BR#3\_STR\_EB.dgn  
 12/19/2019 2:03:23 PM