

NOTES

STIRRUPS IN CAP MAY BE SHIFTED AS NECESSARY TO CLEAR DOWELS.

THE CONCRETE IN THE SHADED AREA OF THE WING SHALL BE POURED AFTER THE VERTICAL CONCRETE BARRIER RAIL IS CAST IF SLIP FORMING IS USED.

FOR PILE SPlice DETAILS, SEE SHEET 4 OF 4.

FOR WING DETAILS, SEE SHEET 3 OF 4.

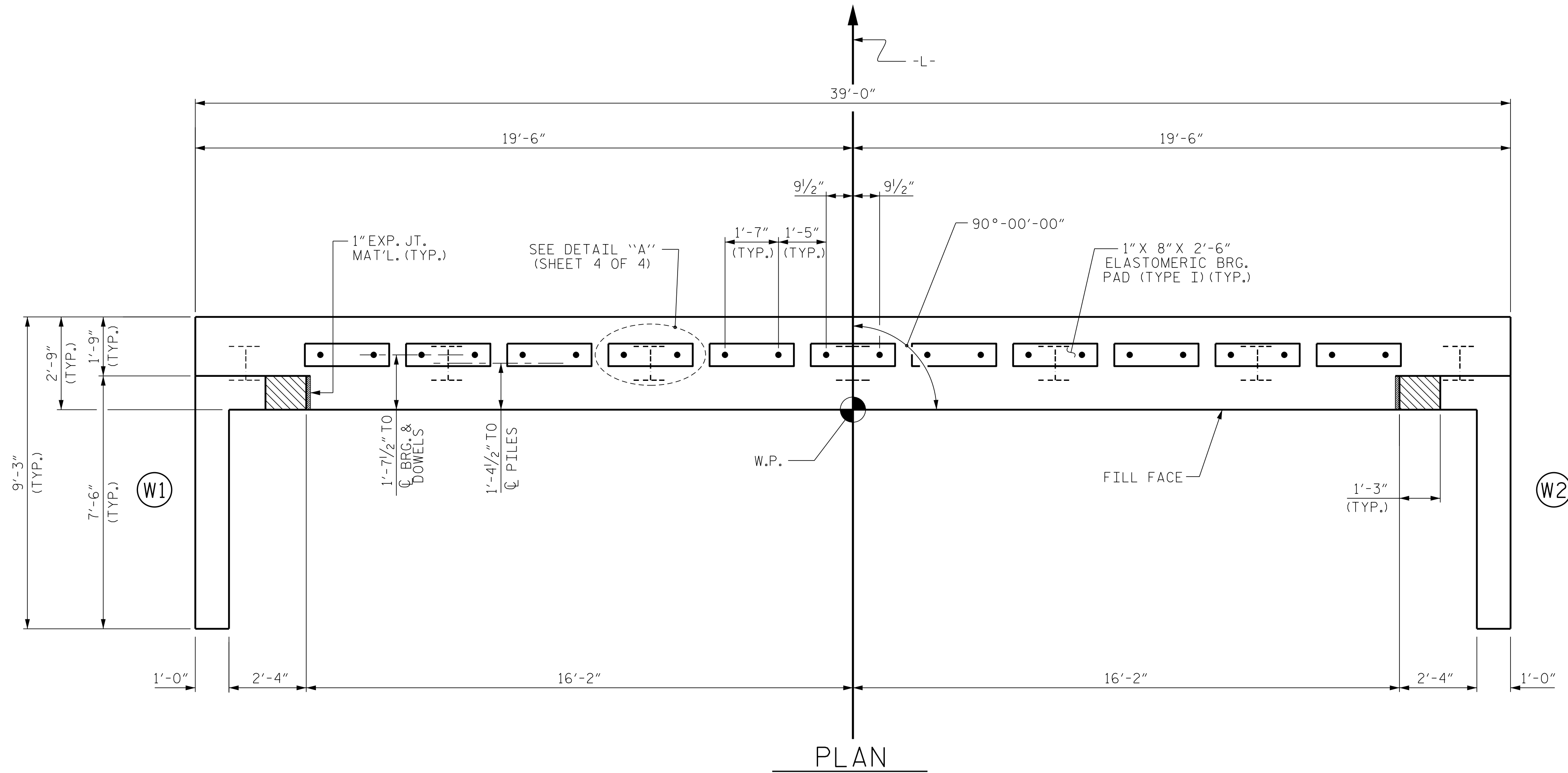

PLAN

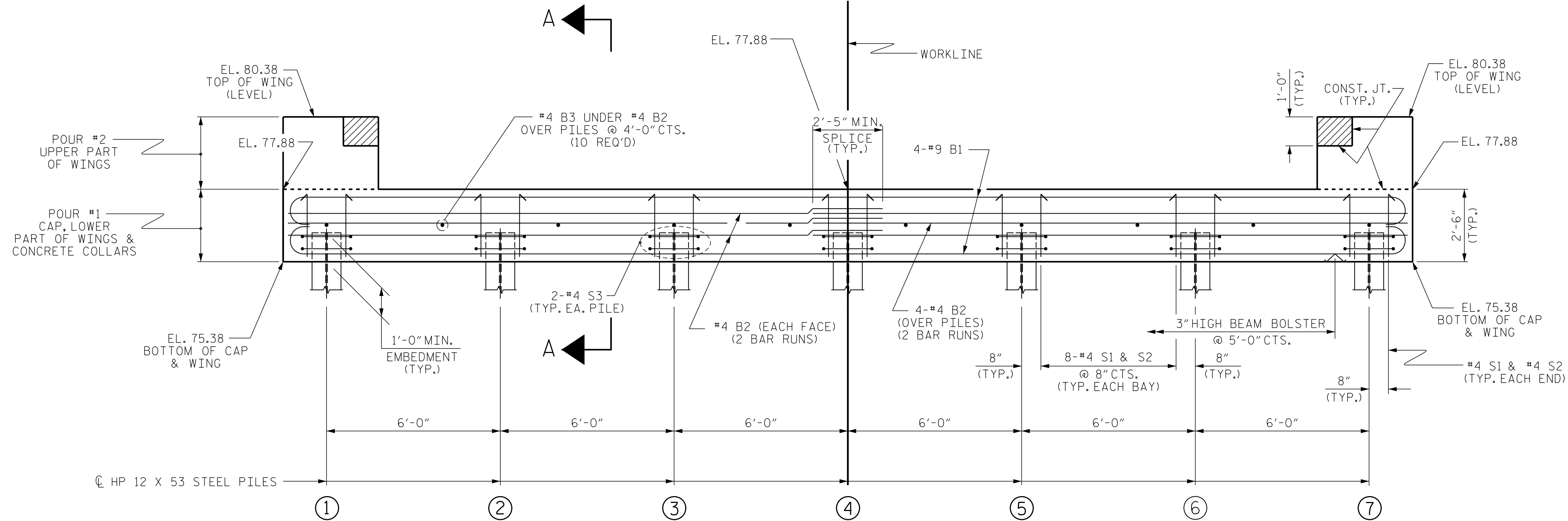

ELEVATION

WINGS NOT SHOWN FOR CLARITY.
FOR SECTION A-A, SEE SHEET 4 OF 4.
CONCRETE COLLARS FOR STEEL PILES NOT SHOWN IN PLAN AND ELEVATION VIEWS FOR CLARITY.
SEE "CORROSION PROTECTION FOR STEEL PILES DETAIL", SHEET 4 OF 4.

PROJECT NO. BR-0111
EDGEcombe COUNTY
STATION: 35+90.50 -L-

SHEET 1 OF 4

ENGINEER OF RECORD
2/20/2020

Designed by:
John Arthur Dillworth
1223 Jones Franklin Rd.
Raleigh, N.C. 27606
Bus: 919 851 8077
Fax: 919 851 8107
LICENSE NO. F-0377

STATE OF NORTH CAROLINA DEPARTMENT OF TRANSPORTATION RALEIGH					
SUBSTRUCTURE END BENT No. 1					
REVISIONS					
NO.	BY:	DATE:	NO.	BY:	DATE:
1			3		
2			4		
					SHEET NO. S03-8
					TOTAL SHEETS 17

ASSEMBLED BY : J. PENDERGRAFT	DATE : 6-19
CHECKED BY : J. DILWORTH	DATE : 8-19
DRAWN BY : DGE	01/10
CHECKED BY : MKT	01/10
REV. 4/15	MAA/TMG

DOCUMENT NOT CONSIDERED FINAL
UNLESS ALL SIGNATURES COMPLETED

P:\2019\1910401 BR-0111\Structures\DNBR\IDG 3\BR0111_BR#3_STR_EB.dgn 12/19/2019 2:01:56 PM