

P:\2019\1910401\_BR0111\Structures\DNBR\ID6E\_3\BR0111\_BR#3\_STR\_PS.dgn  
 12/19/2019 1:47:54 PM

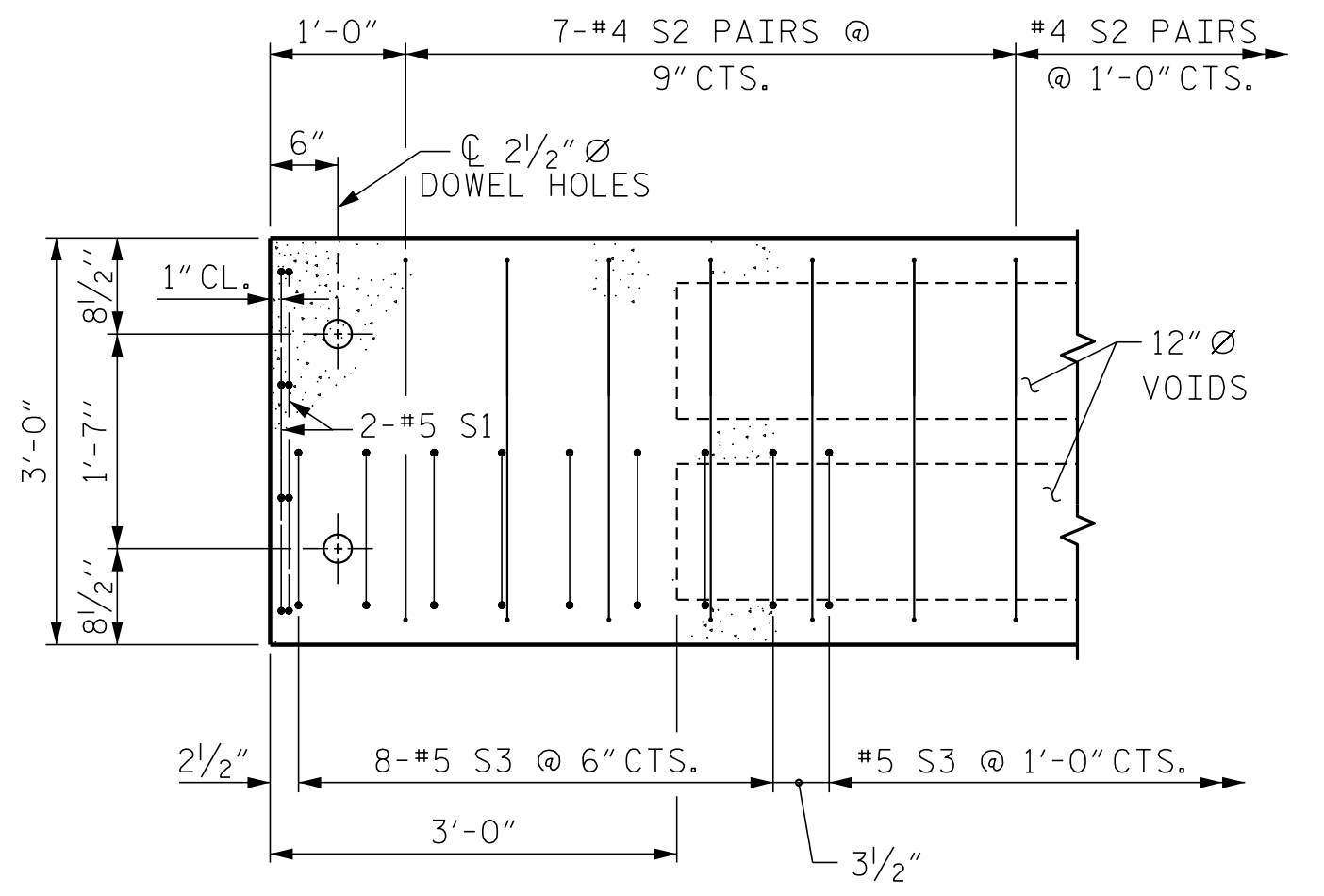
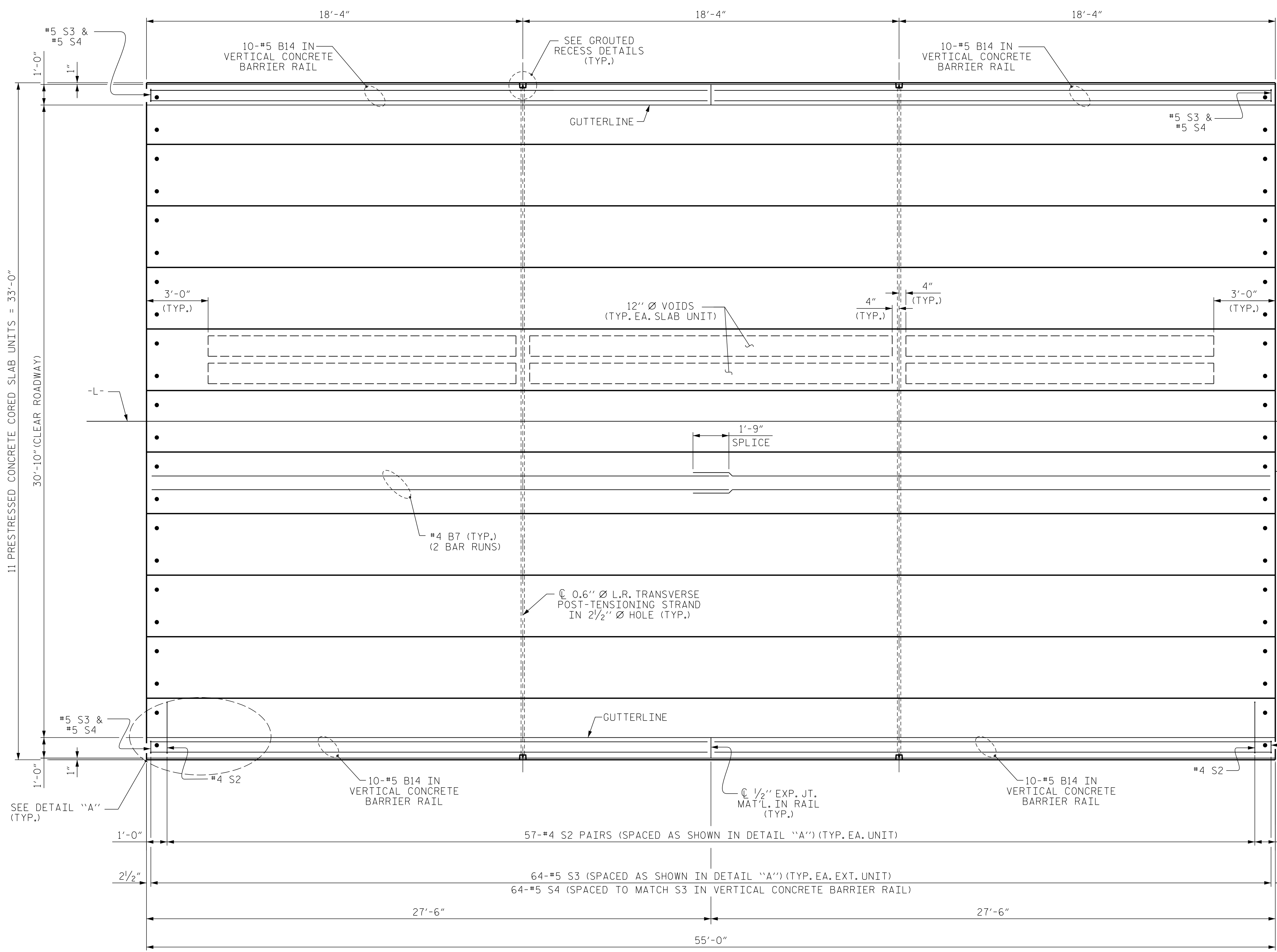

**DETAIL "A"**  
 (TYPICAL EACH END OF UNIT)  
 NOTE: EXTERIOR UNIT SHOWN - INTERIOR UNIT SIMILAR EXCEPT OMIT #5 S3 BARS.

**PLAN OF UNIT**

PROJECT NO. BR-0111  
EDGEcombe COUNTY  
 STATION: 35+90.50 -L-  
 SHEET 2 OF 3

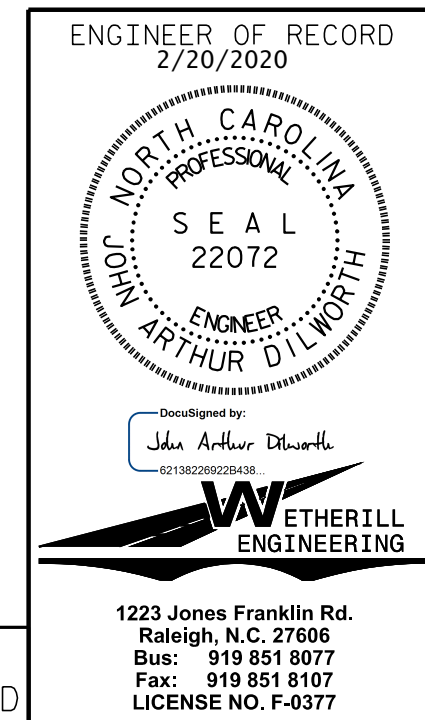

|  |     |       |     |     |                    |
|--|-----|-------|-----|-----|--------------------|
| STATE OF NORTH CAROLINA<br>DEPARTMENT OF TRANSPORTATION<br>RALEIGH       |     |       |     |     |                    |
| PLAN OF 55' UNIT<br>30'-10" CLEAR ROADWAY<br>90° SKEW<br>SPAN A, B AND C |     |       |     |     |                    |
| REVISIONS  |     |       |     |     |                    |
| NO.  | BY: | DATE: | NO. | BY: | DATE:              |
| 1  |     |       | 3   |     |                    |
| 2  |     |       | 4   |     |                    |
| SHEET NO.<br>S03-5   |     |       |     |     | TOTAL SHEETS<br>17 |

|                               |                      |
|-------------------------------|----------------------|
| ASSEMBLED BY : J. PENDERGRAFT | DATE : 6-19          |
| CHECKED BY : J. DILWORTH      | DATE : 8-19          |
| DRAWN BY : DGE 3/09           | REV. 12/5/11 MAA/AAC |
| CHECKED BY : BCH 3/09         | REV. 8/14 MAA/TMG    |

DOCUMENT NOT CONSIDERED FINAL  
UNLESS ALL SIGNATURES COMPLETED

1223 Jones Franklin Rd.  
 Raleigh, N.C. 27606  
 Bus: 919 851 8077  
 Fax: 919 851 8107  
 LICENSE NO. F-0377

STD. NO. 21" PCS\_33\_90S\_55L