

NOTES

STIRRUPS IN CAP MAY BE SHIFTED AS NECESSARY TO CLEAR DOWELS.

★ INVERT ALTERNATE STIRRUPS.

GALVANIZE THE TOP OF EACH INTERIOR BENT PILE A MINIMUM OF 25 FEET. GALVANIZE IN ACCORDANCE WITH SECTION 1076 OF THE STANDARD SPECIFICATIONS.

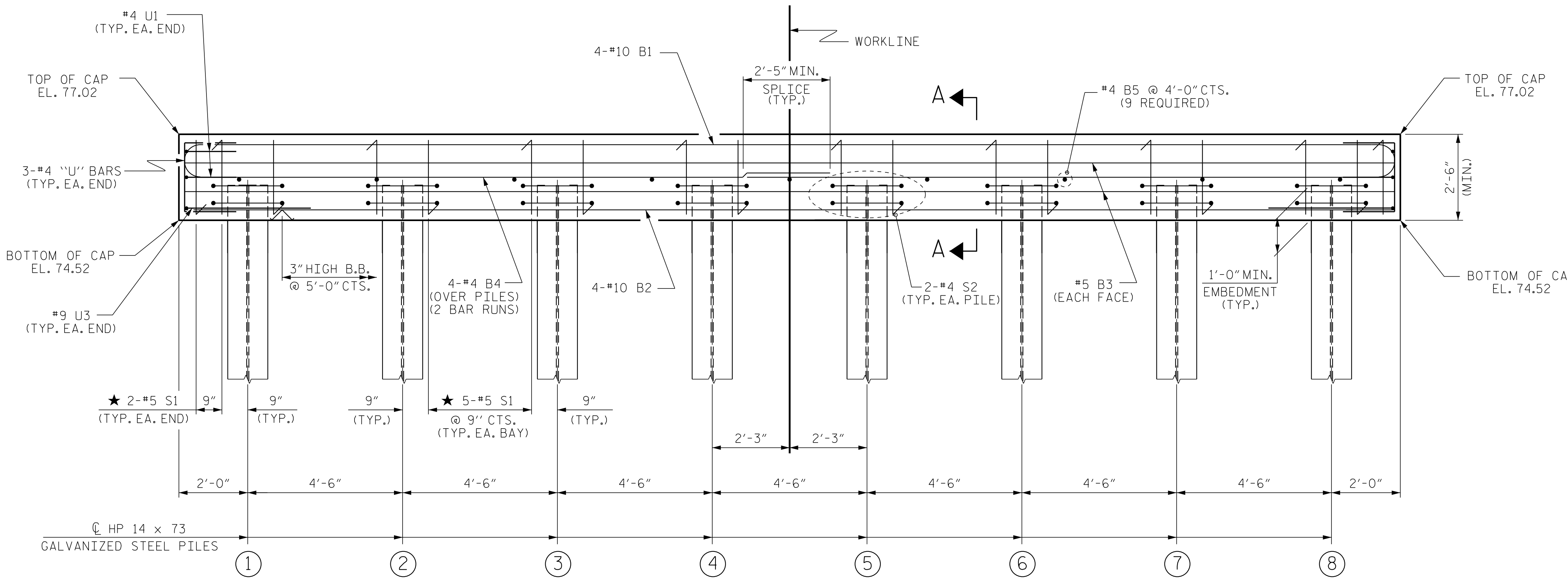
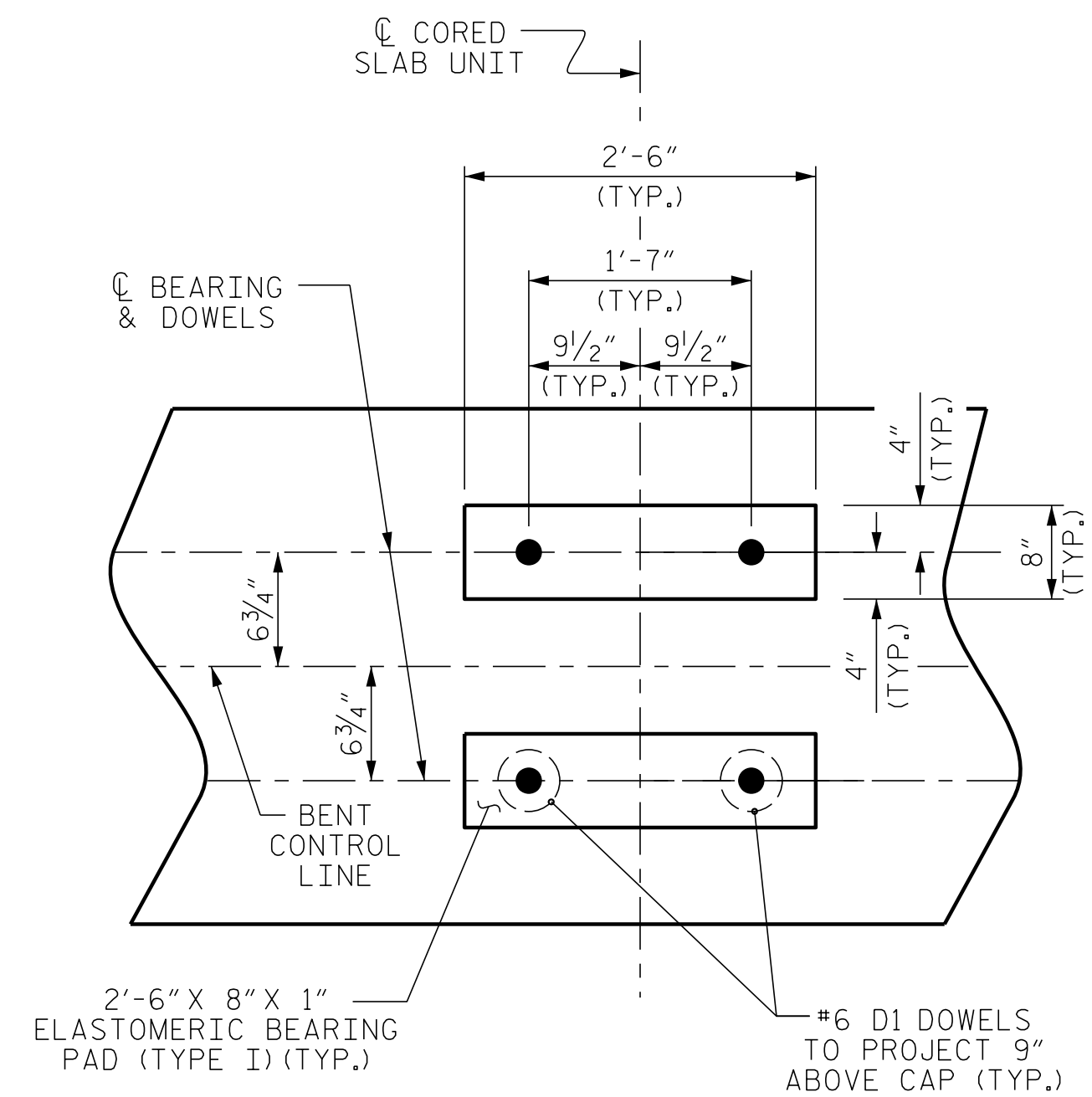
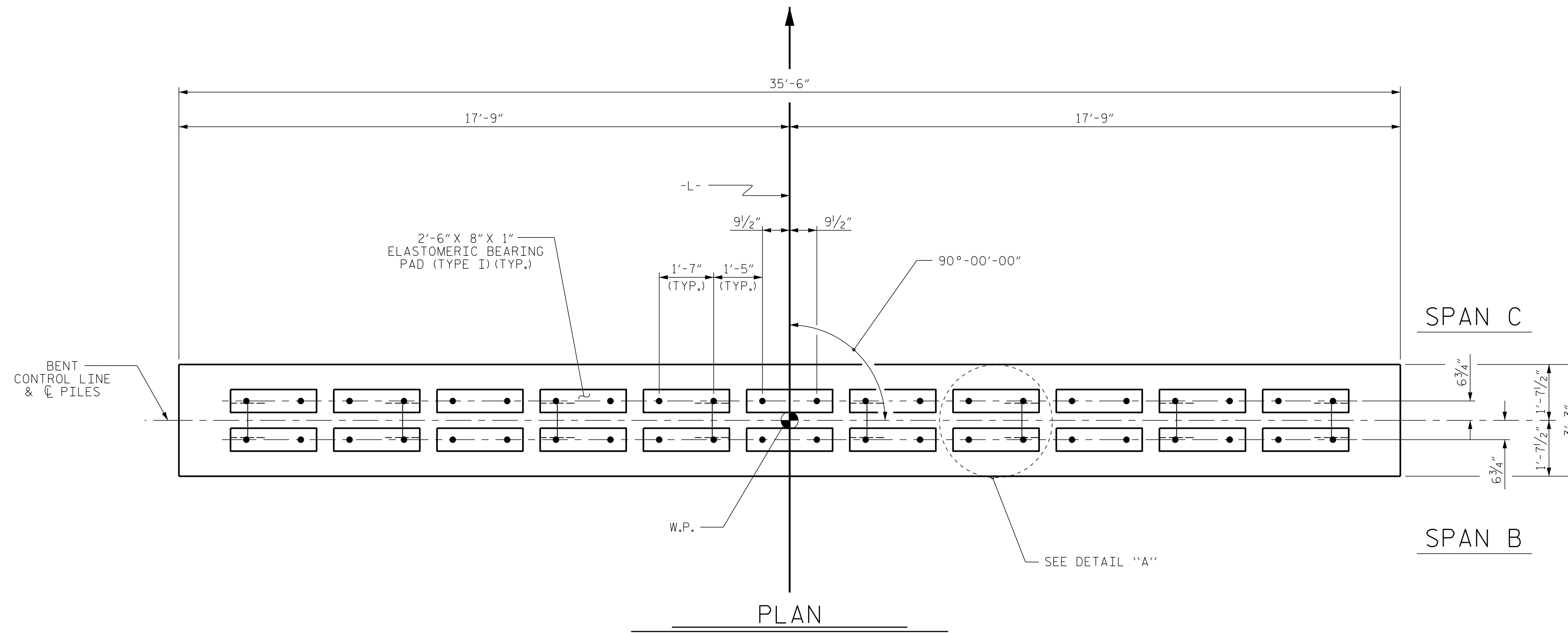

PROJECT NO. BR-0111
 EDGECOMBE COUNTY
 STATION: 31+08.50 -L-
 SHEET 1 OF 2

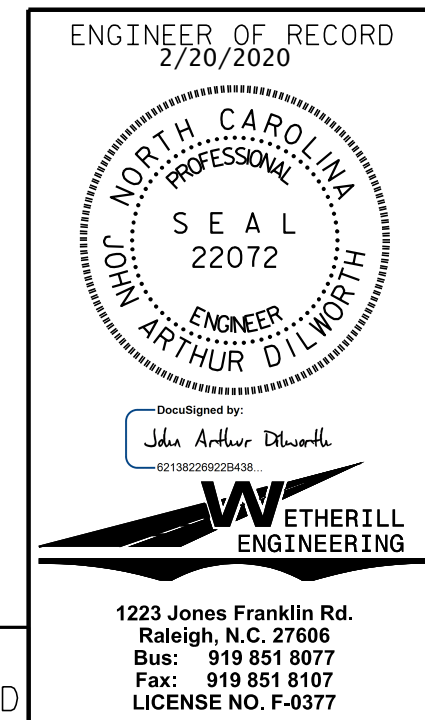

STATE OF NORTH CAROLINA DEPARTMENT OF TRANSPORTATION RALEIGH					
SUBSTRUCTURE BENT No. 2					
REVISIONS					
NO.	BY:	DATE:	NO.	BY:	DATE:
1			3		
2			4		
SHEET NO. S02-14					TOTAL SHEETS 17

DOCUMENT NOT CONSIDERED FINAL UNLESS ALL SIGNATURES COMPLETED

P:\2019\1910401 BR-0111\Structures\DNBR\IDG64\BR0111_BR#4_STR_BT.dgn
 12/19/2019 10:56:35 AM

ASSEMBLED BY : J. PENDERGRAFT	DATE : 6-19
CHECKED BY : J. DILWORTH	DATE : 8-19
DRAWN BY : DGE	05/10
CHECKED BY : MKT	05/10
REV. 6/17	MAA/THC