

NOTES

STIRRUPS IN CAP MAY BE SHIFTED AS NECESSARY TO CLEAR DOWELS.

★ INVERT ALTERNATE STIRRUPS.

GALVANIZE THE TOP OF EACH INTERIOR BENT PILE A MINIMUM OF 29 FEET. GALVANIZE IN ACCORDANCE WITH SECTION 1076 OF THE STANDARD SPECIFICATIONS.

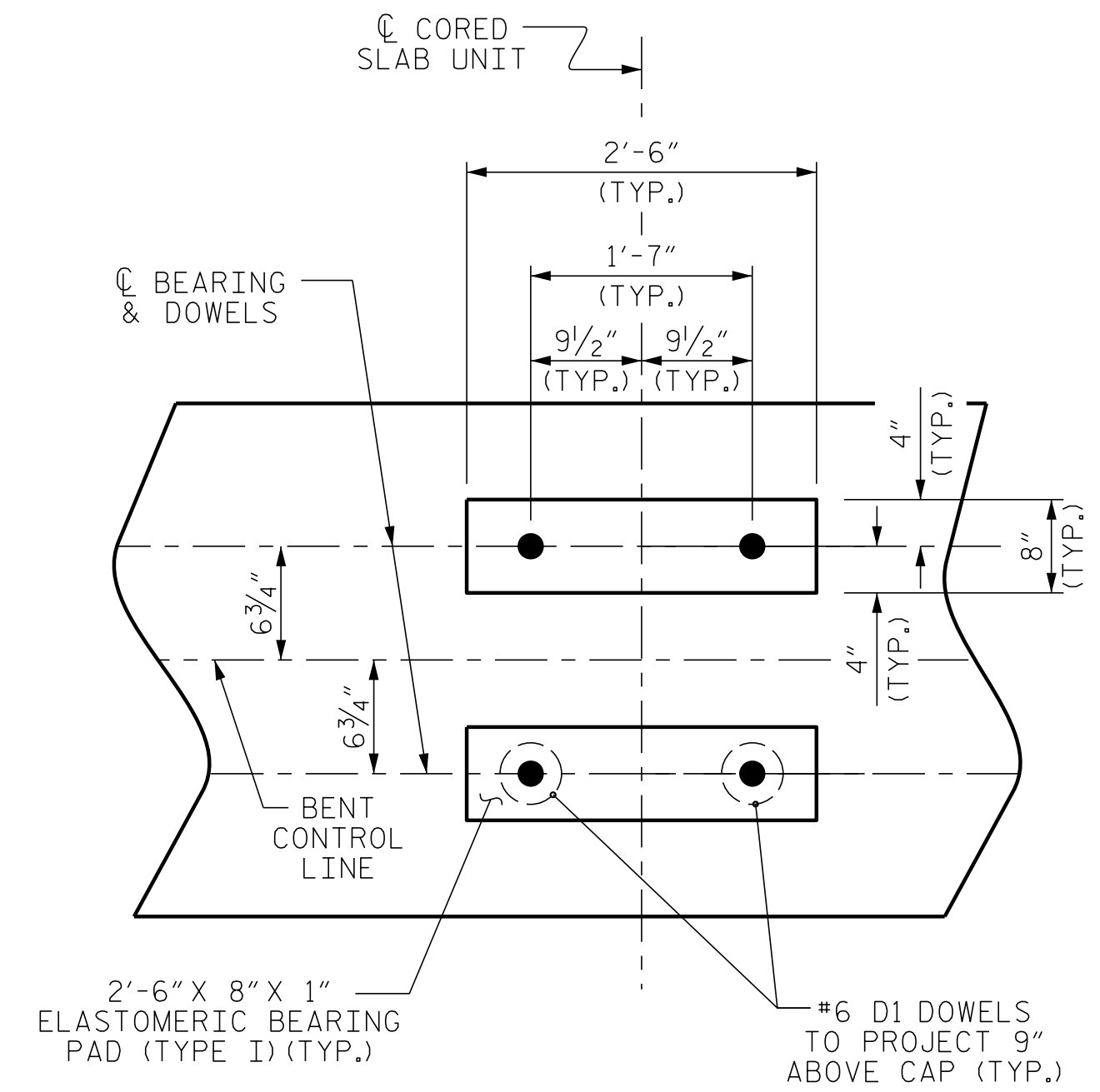
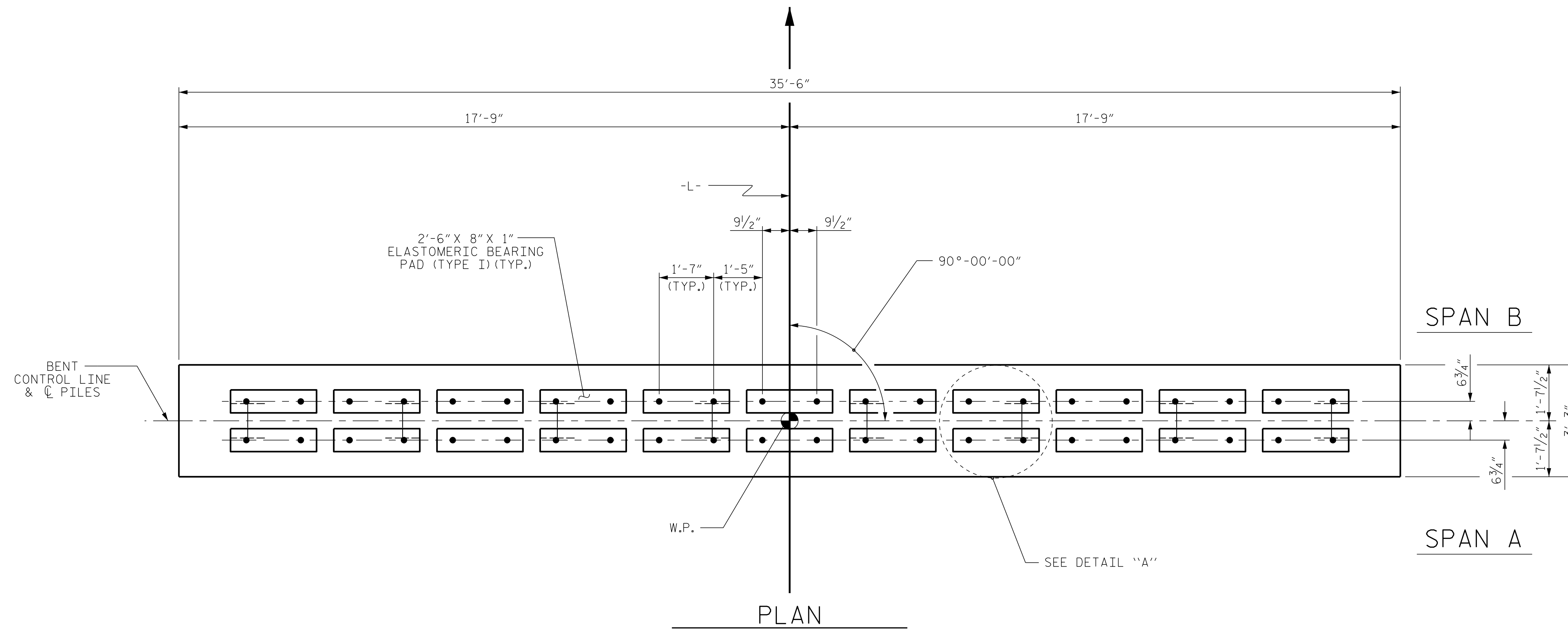

DETAIL "A"

(DIMENSIONS ARE TYPICAL EACH BEARING)

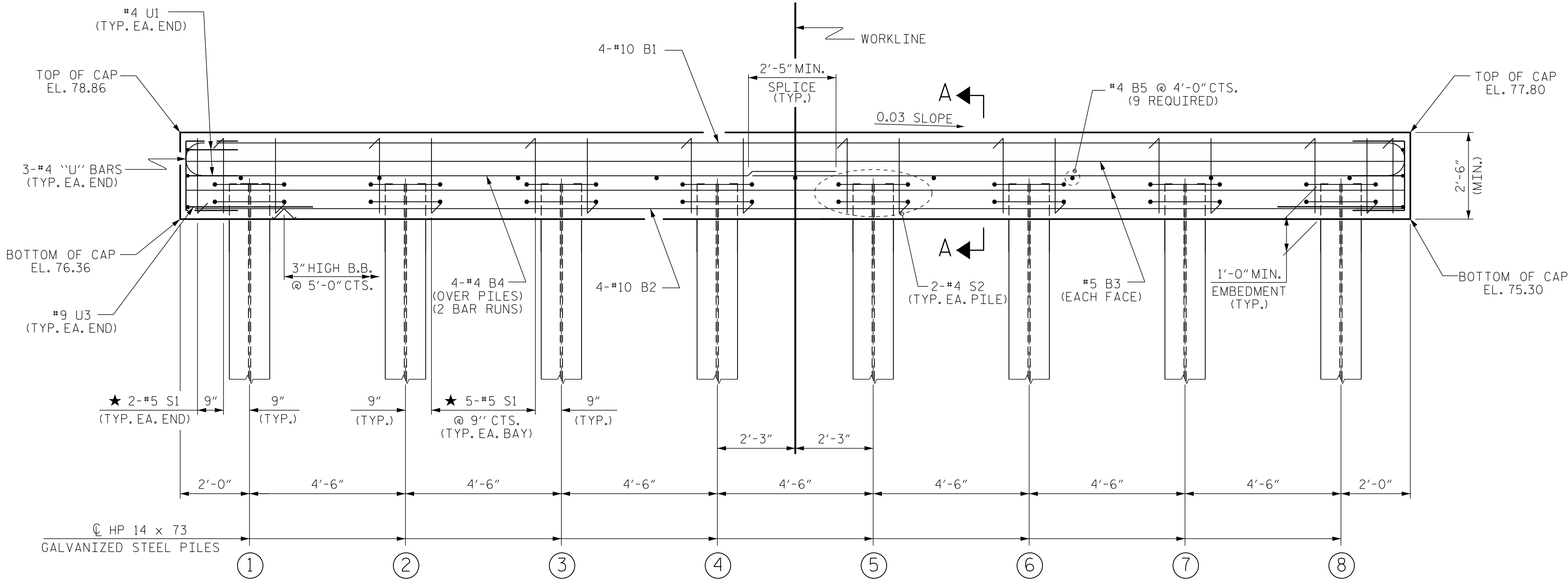

TOP OF PILE ELEVATIONS

①	77.30
②	77.17
③	77.03
④	76.90
⑤	76.76
⑥	76.63
⑦	76.49
⑧	76.36

PROJECT NO. BR-0111
 EDGEcombe COUNTY
 STATION: 16+80.00 -L-

SHEET 1 OF 2

ELEVATION

FOR SECTION A-A, SEE SHEET 2 OF 2

ASSEMBLED BY : J. PENDERGRAFT DATE : 6-19
 CHECKED BY : J. DILWORTH DATE : 8-19
 DRAWN BY : DGE 05/10
 CHECKED BY : MKT 05/10
 REV. 6/17 MAA/THC

DOCUMENT NOT CONSIDERED FINAL
 UNLESS ALL SIGNATURES COMPLETED

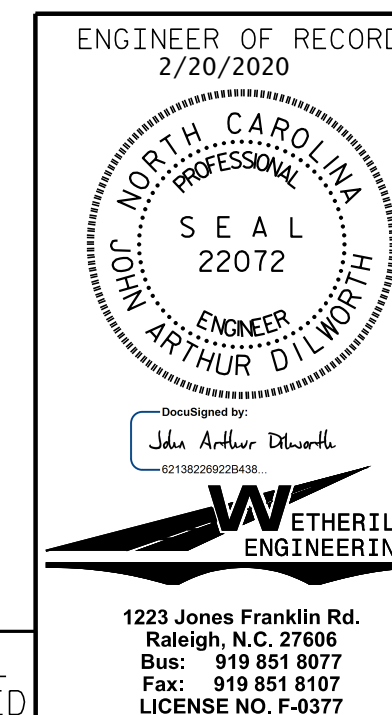

STATE OF NORTH CAROLINA
 DEPARTMENT OF TRANSPORTATION
 RALEIGH

SUBSTRUCTURE
 BENT No. 1

REVISIONS					
NO.	BY:	DATE:	NO.	BY:	DATE:
1			3		
2			4		

SHEET NO. S01-15
 TOTAL SHEETS 18

STD. NO. 14" HP_BT_33_90S_<60'

P:\2019\1910401 BR-0111\Structures\DNBR\IDG 5\BR0111_BR#5_STR_BT.dgn
 12/18/2019 3:41:53 PM