

NOTES:
 THE CONTRACTOR SHALL CUT THE EXISTING #5 "S" REBARS EXTENDING INTO THE BARRIER FROM THE DECK AND THE LONGITUDINAL #5 REBAR WITHIN THE LIMIT OF THE PROPOSED RUBBER PLATE JOINT. ALL EXPOSED ENDS OF THESE BARS SHALL BE COATED WITH EPOXY PRIOR TO THE NEW JOINT MATERIAL INSTALLATION.

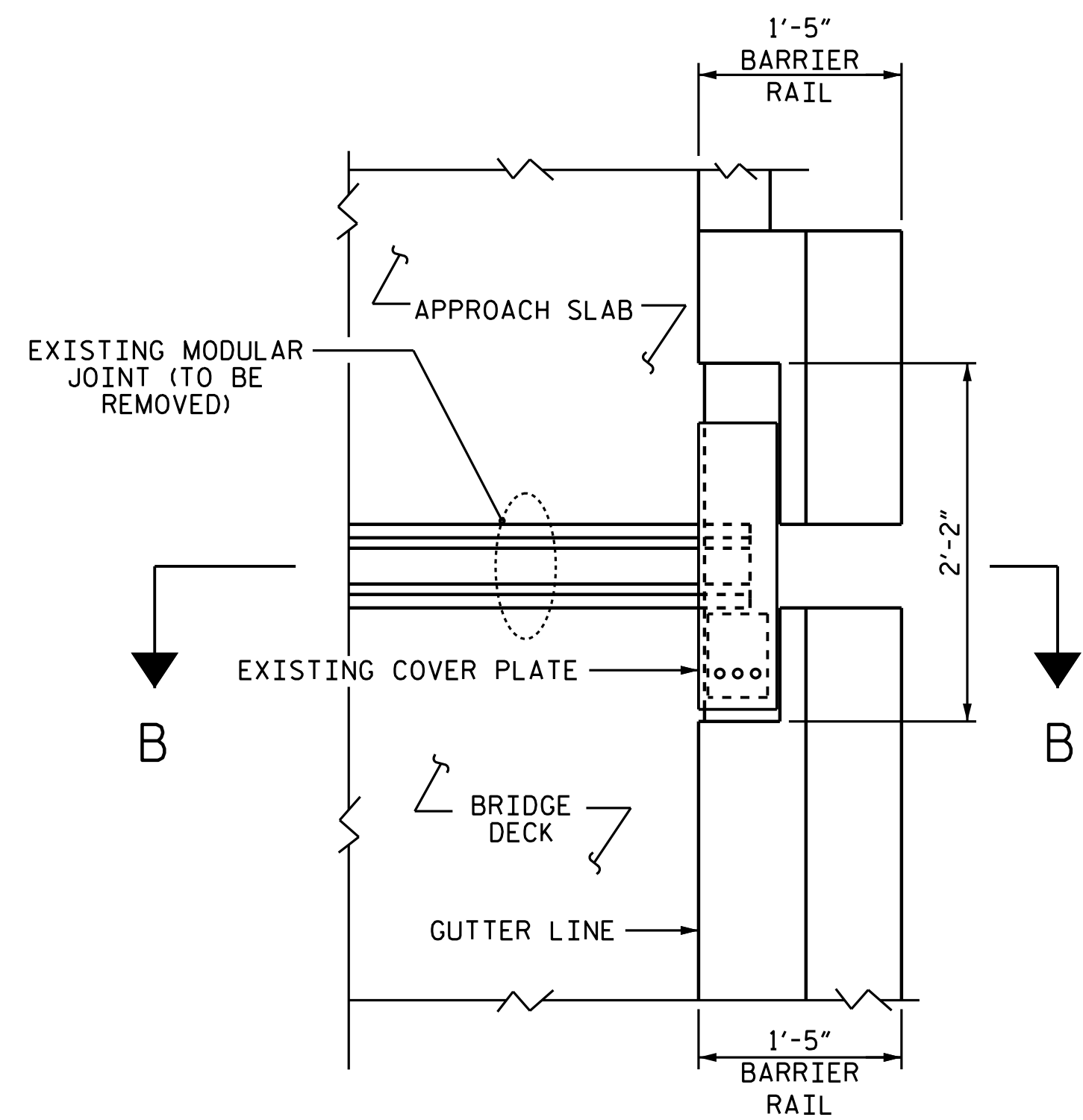

PLAN OF EXISTING MODULAR EXPANSION JOINT SEAL

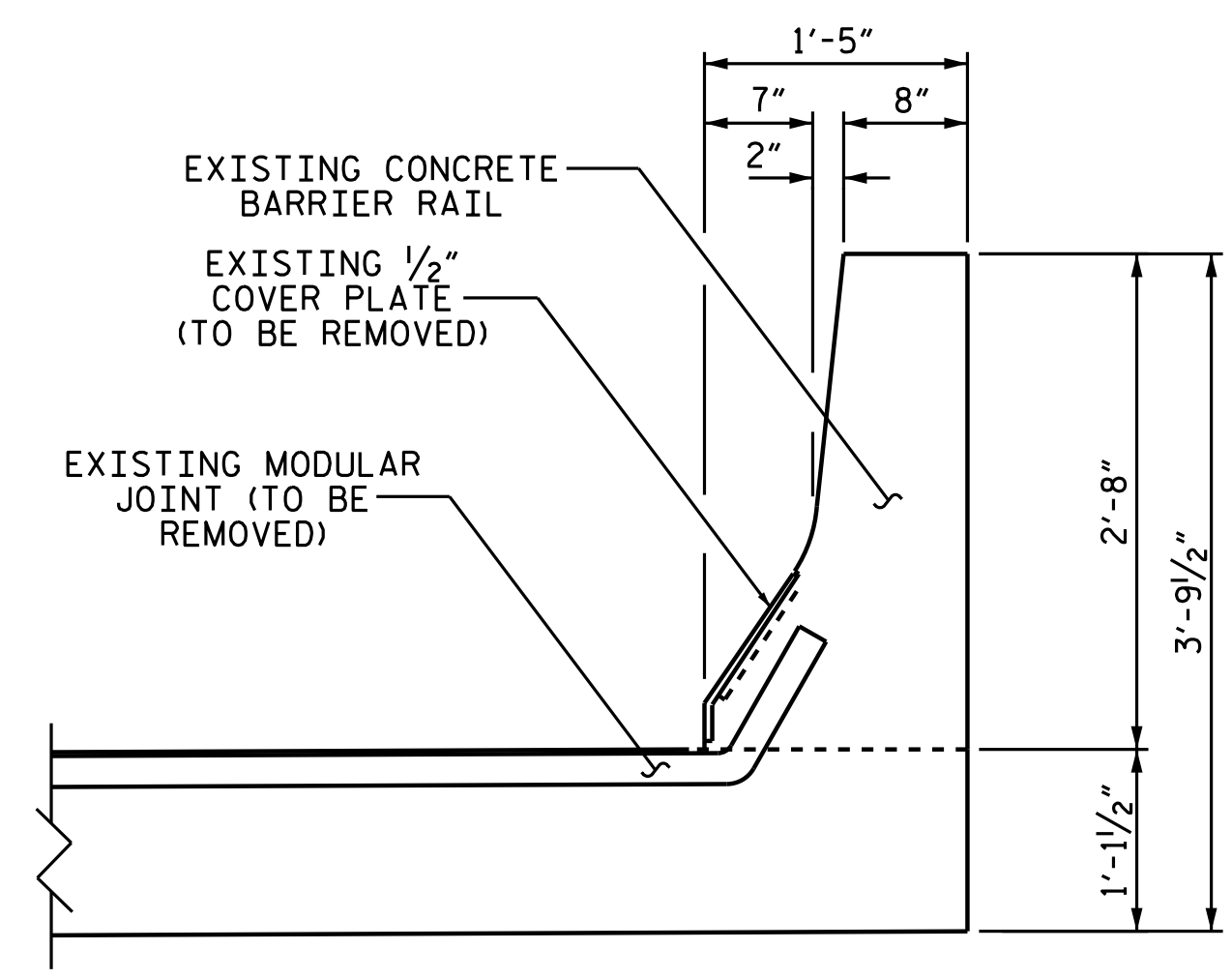

SECTION B-B

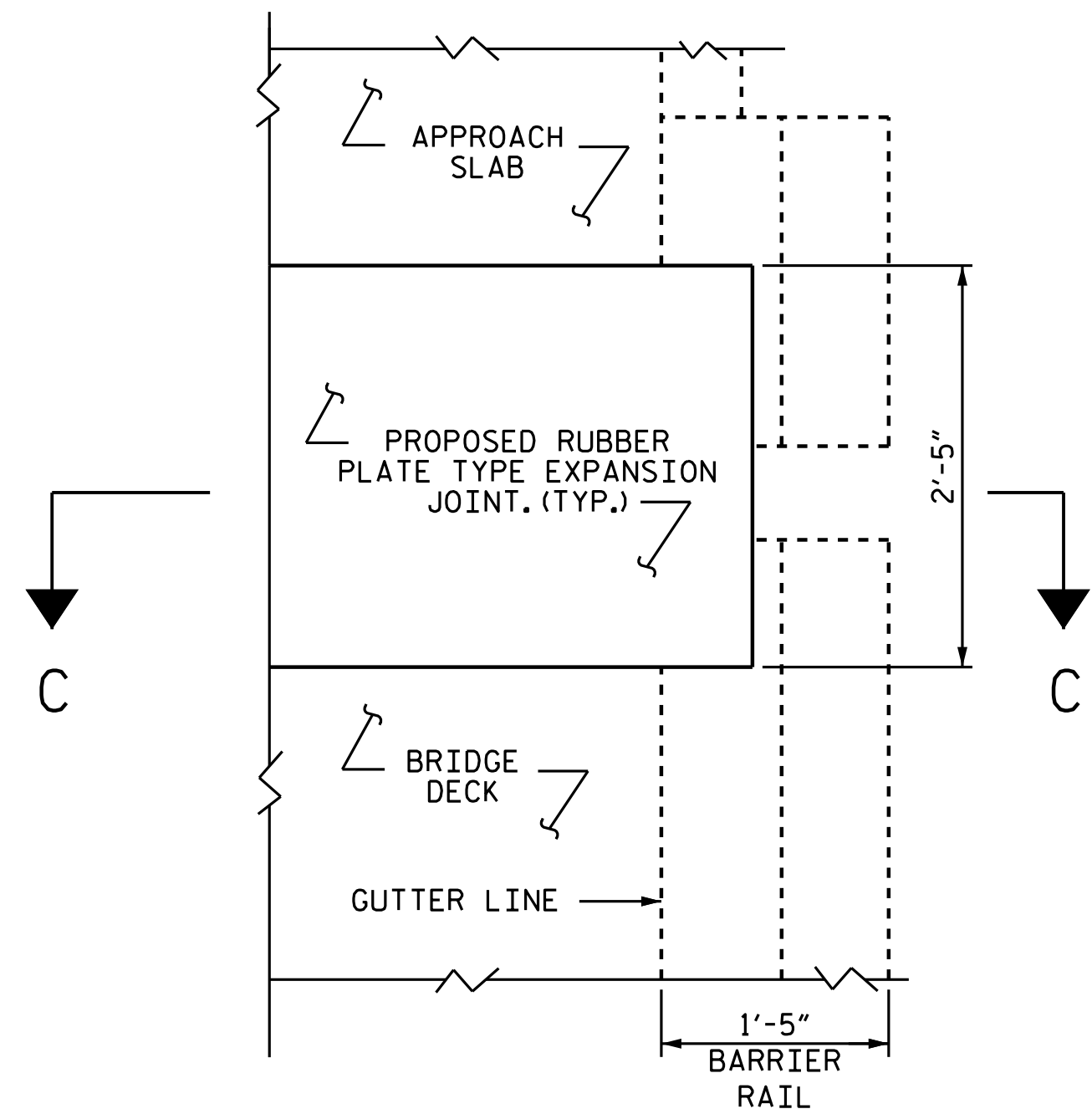

PLAN OF PROPOSED EXPANSION JOINT SEAL

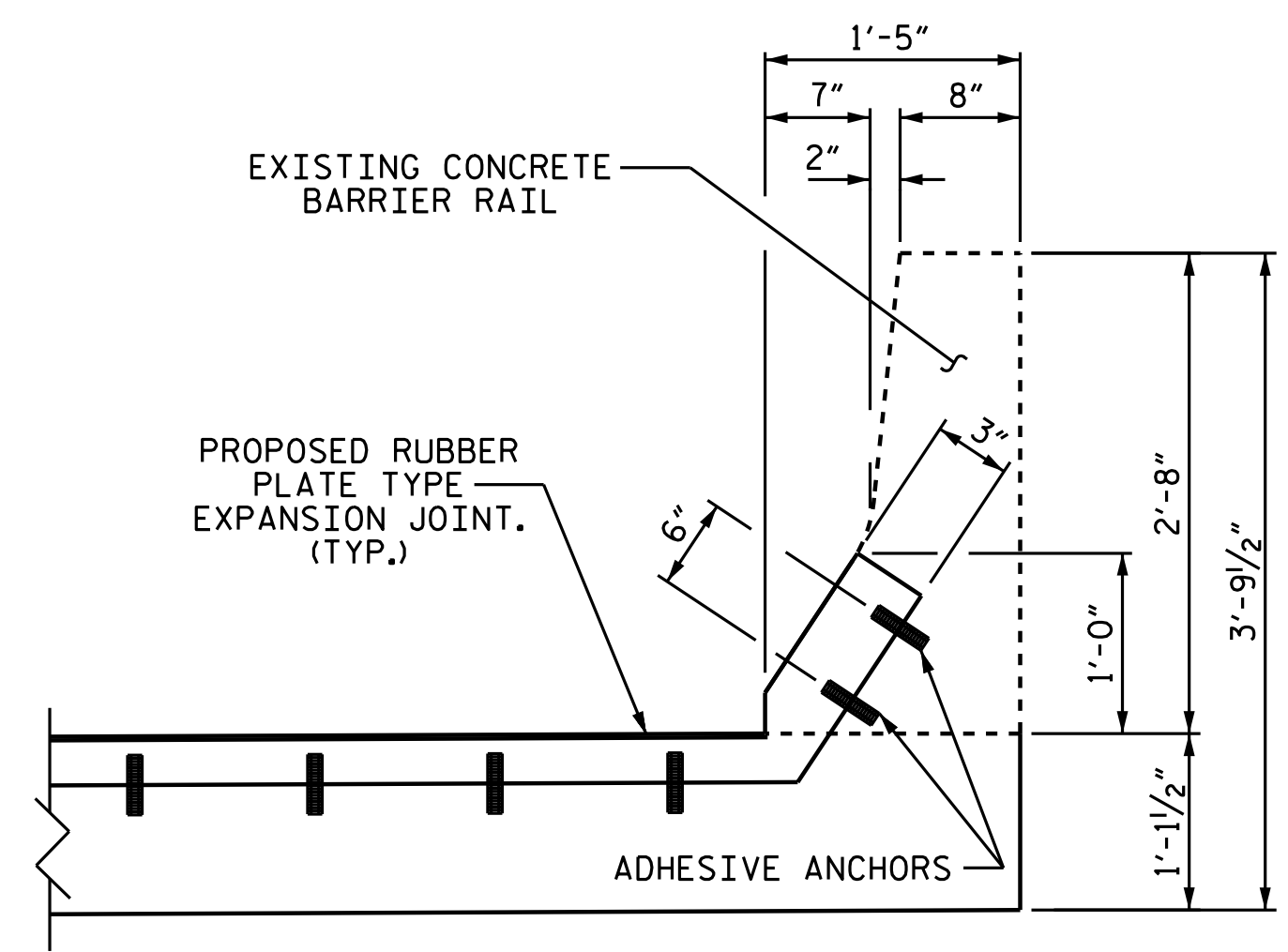

SECTION C-C
 (THE NEW RUBBER PLATE BRIDGE JOINT SHALL BE TURNED UP AND FLUSH WITH THE FACE OF THE BARRIER)

PROJECT NO. I-5795
FORSYTH COUNTY
 BRIDGE NO. 330444

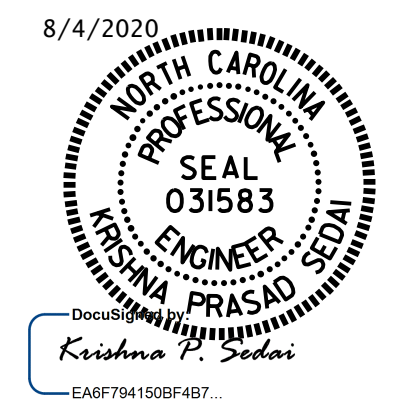

STATE OF NORTH CAROLINA
 DEPARTMENT OF TRANSPORTATION
 RALEIGH
 JOINT DETAIL AT
 THE BARRIER RAIL
 END BENT 2
 END BENT 1 SIMILAR

DRAWN BY : A. SORSENGINH DATE : 5/2018
 CHECKED BY : M. G. SHAIKH DATE : 5/2018

REVISIONS						SHEET NO.
NO.	BY:	DATE:	NO.	BY:	DATE:	S17-09
1			3			TOTAL SHEETS
2			4			10

DOCUMENT NOT CONSIDERED
 FINAL UNLESS ALL
 SIGNATURES COMPLETED