

**JOINT INSTALLATION SEQUENCE AT END BENTS**  
SECTION A-A

**NOTE**  
THE CONTRACTOR SHALL FIELD VERIFY THE EXISTING JOINT OPENING PRIOR TO ORDERING JOINT SEAL MATERIAL. IF ACTUAL JOINT OPENING VARIES FROM THE OPENING INDICATED IN DETAIL BY MORE THAN 1/4", NOTIFY ENGINEER. REVISION TO THE JOINT SEAL SIZE MIGHT BE NECESSARY.

FINAL JOINT SEALS SHALL NOT BE INSTALLED UNTIL THE OVERLAY IS COMPLETE.

THE CONTRACTOR SHALL TAKE CARE DURING JOINT REHAB OPERATIONS NOT TO DROP ANY MATERIAL BELOW THE BRIDGE WITHOUT PROTECTIVE DEVICES BELOW TO CATCH THE MATERIAL. ANY MATERIAL THAT FALLS BELOW THE BRIDGE SHALL BE CONTAINED, REMOVED AND DISPOSED OF BY THE CONTRACTOR AT NO EXTRA COST TO THE DEPARTMENT. IF THE ENGINEER DETERMINES THAT THE PROTECTIVE DEVICES ARE NOT ADEQUATE OR NOT BEING EMPLOYED, THE WORK SHALL BE SUSPENDED UNTIL ADEQUATE PROTECTION IS PROVIDED.

THE CONTRACTOR WILL NOT BE PERMITTED TO FORM THE JOINTS IN LIEU OF SAWING THE JOINT.

DURING THE JOINT INSTALLATION PROCEDURE, THE JOINT AND SURROUNDING AREA SHALL BE KEPT CLEAN AND FREE OF DEBRIS.

FOR POURABLE SILICONE JOINT SEALANT, SEE SPECIAL PROVISIONS.

THE MANUFACTURER IS TO PROVIDE THE NOMINAL UNCOMPRESSED SEAL WIDTH OF THE BACKER ROD FOR THE EXISTING JOINT SIZE AND ACCOMMODATE THE MINIMUM EXPANSION SHOWN ON THE PLANS.

A MANUFACTURER'S CERTIFIED TRAINED REPRESENTATIVE SHALL BE PRESENT DURING THE INSTALLATION OF THE FIRST JOINT OF THE PROJECT, OR UNTIL THE ENGINEER IS SATISFIED WITH THE INSTALLATION PROCESS.

THE INSTALLATION OF THE JOINT SEAL SHALL BE WATERTIGHT.

FINAL SURFACE OF THE JOINT DEMOLITION AREA PRIOR TO PLACEMENT OF CONCRETE REPAIR MATERIAL SHOULD BE REASONABLY FLAT AND LEVEL. ENGINEER SHALL DETERMINE THE ACCEPTABILITY OF THE SURFACE PRIOR TO PLACEMENT OF REPAIR CONCRETE.

	CLASS II SURFACE PREPARATION	CONCRETE DECK REPAIR FOR PPC OVERLAY
END BENT 1	7.1 SY	7.1 SY
END BENT 2	7.1 SY	7.1 SY
* TOTAL	14.2 SY	14.2 SY

\* BASED ON THE MINIMUM BLOCKOUT SHOWN.

	ESTIMATE	ACTUAL
POURABLE SILICONE JOINT SEALANT		
END BENT 1	65.3 LF	
END BENT 2	65.7 LF	
TOTAL	131.0 LF	

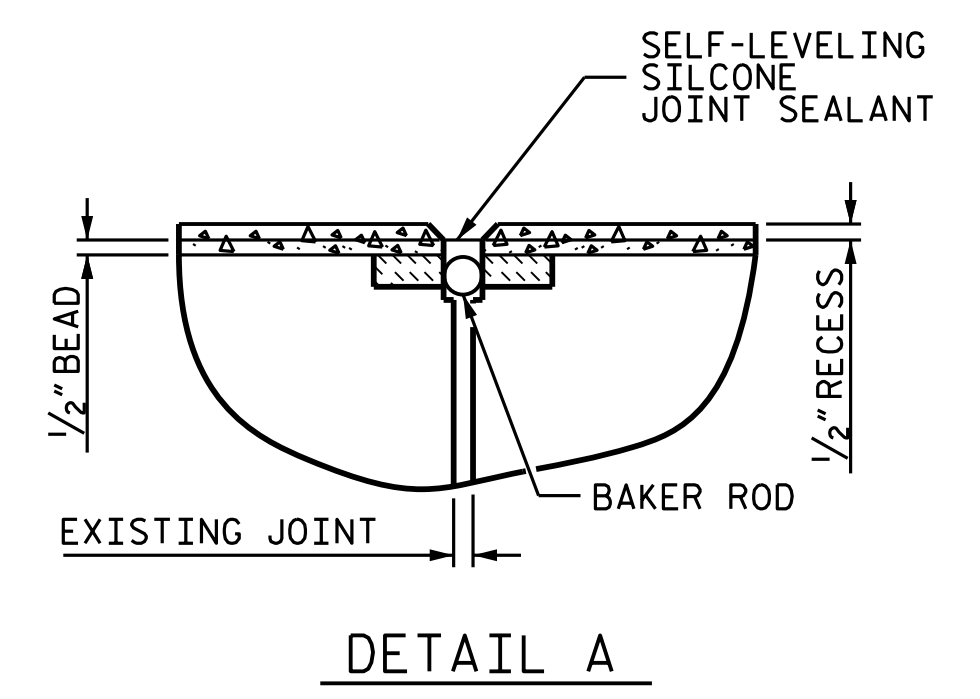
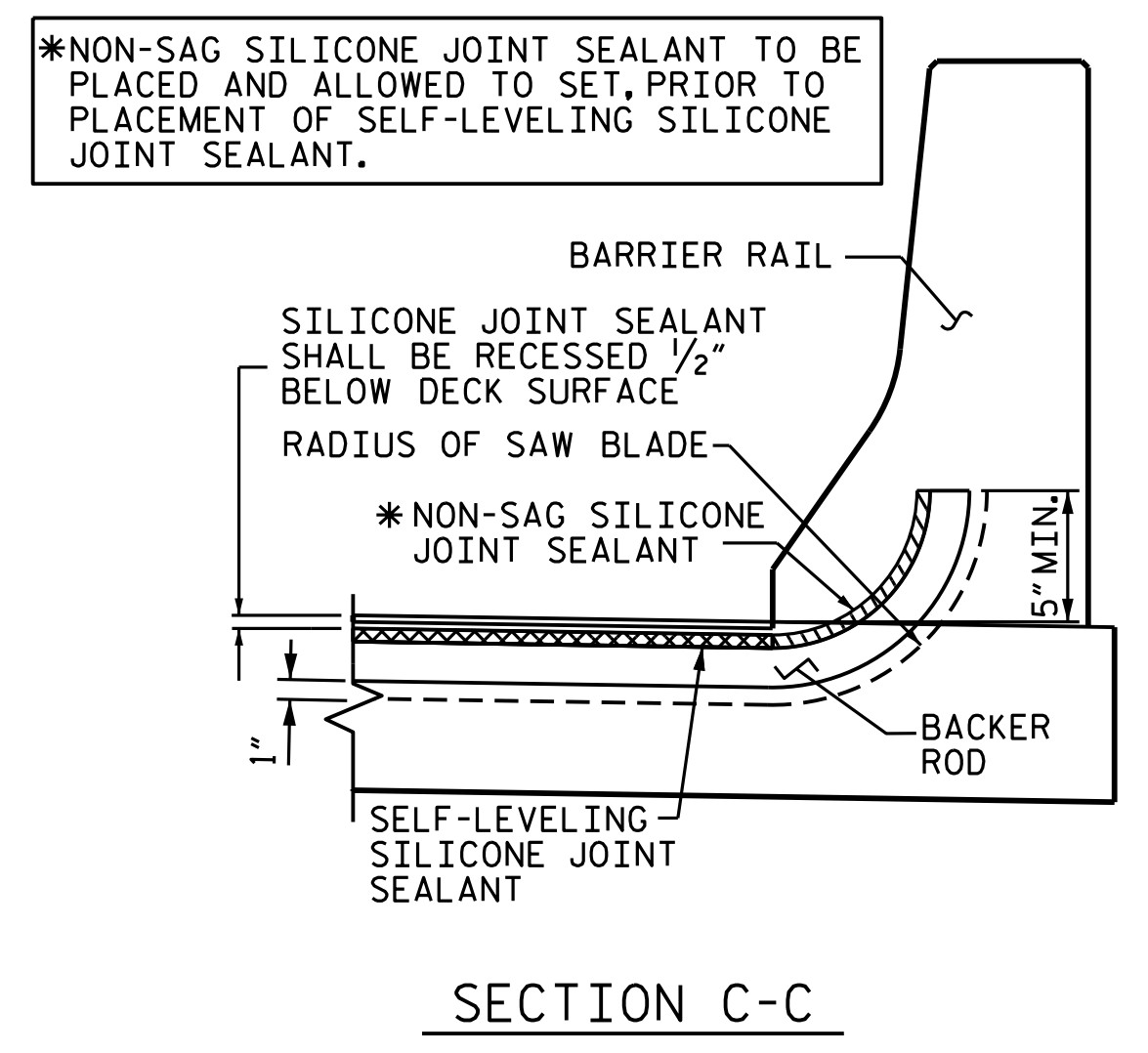
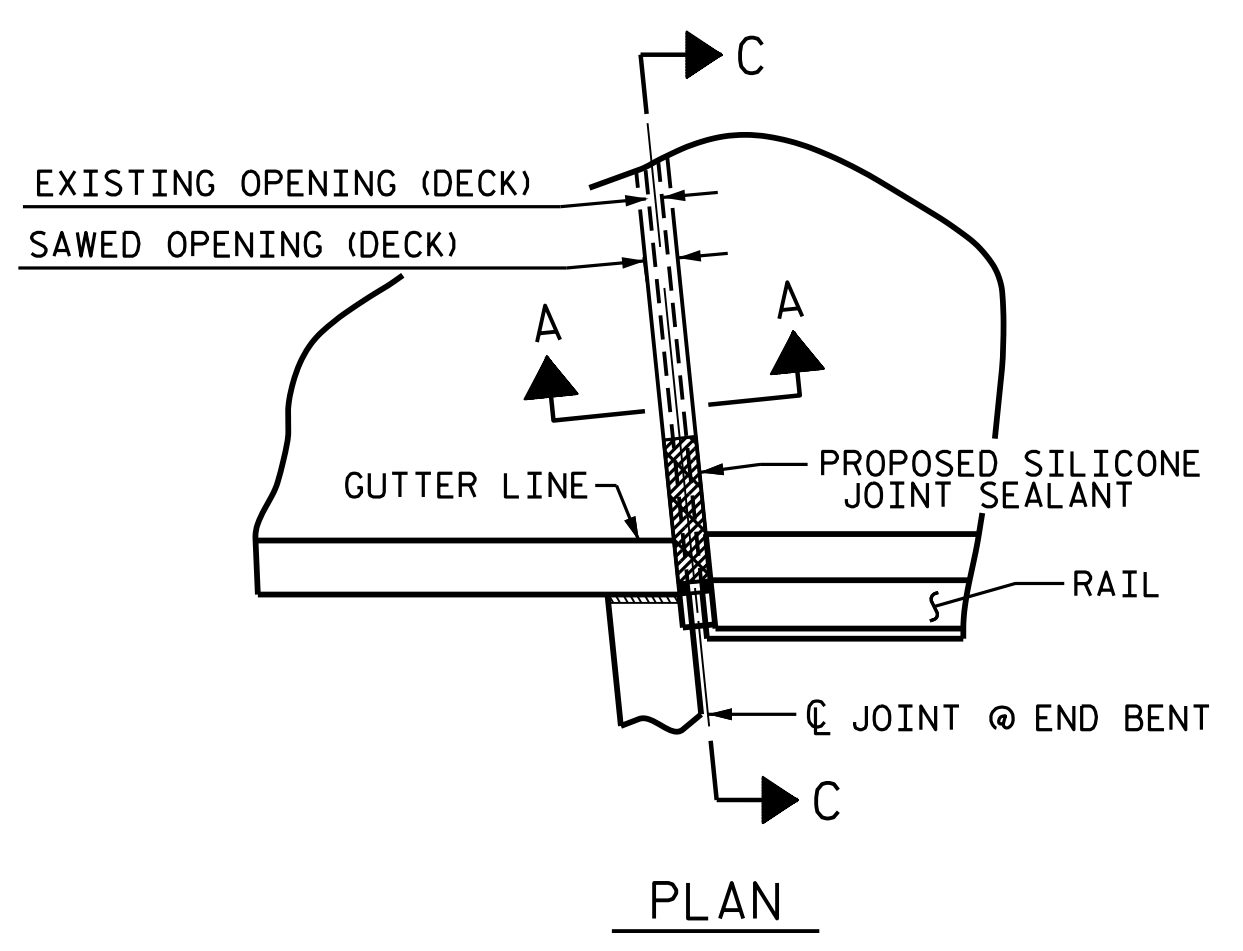

**JOINT DETAILS AT BARRIER RAIL**

PROJECT NO. I-5795  
FORSYTH COUNTY  
BRIDGE NO. 330489

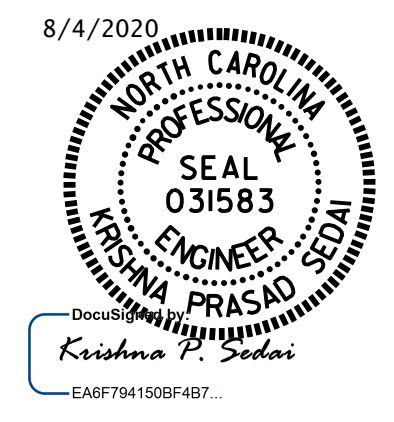

STATE OF NORTH CAROLINA  
DEPARTMENT OF TRANSPORTATION  
RALEIGH

**JOINT DETAILS**

DRAWN BY : A. SORSENGINH DATE : 7/2019  
CHECKED BY : E. BAYISSA DATE : 1/2020

REVISIONS						SHEET NO.
NO.	BY:	DATE:	NO.	BY:	DATE:	S14-04
1			3			TOTAL SHEETS
2			4			6

DOCUMENT NOT CONSIDERED FINAL UNLESS ALL SIGNATURES COMPLETED