

EXISTING JOINT

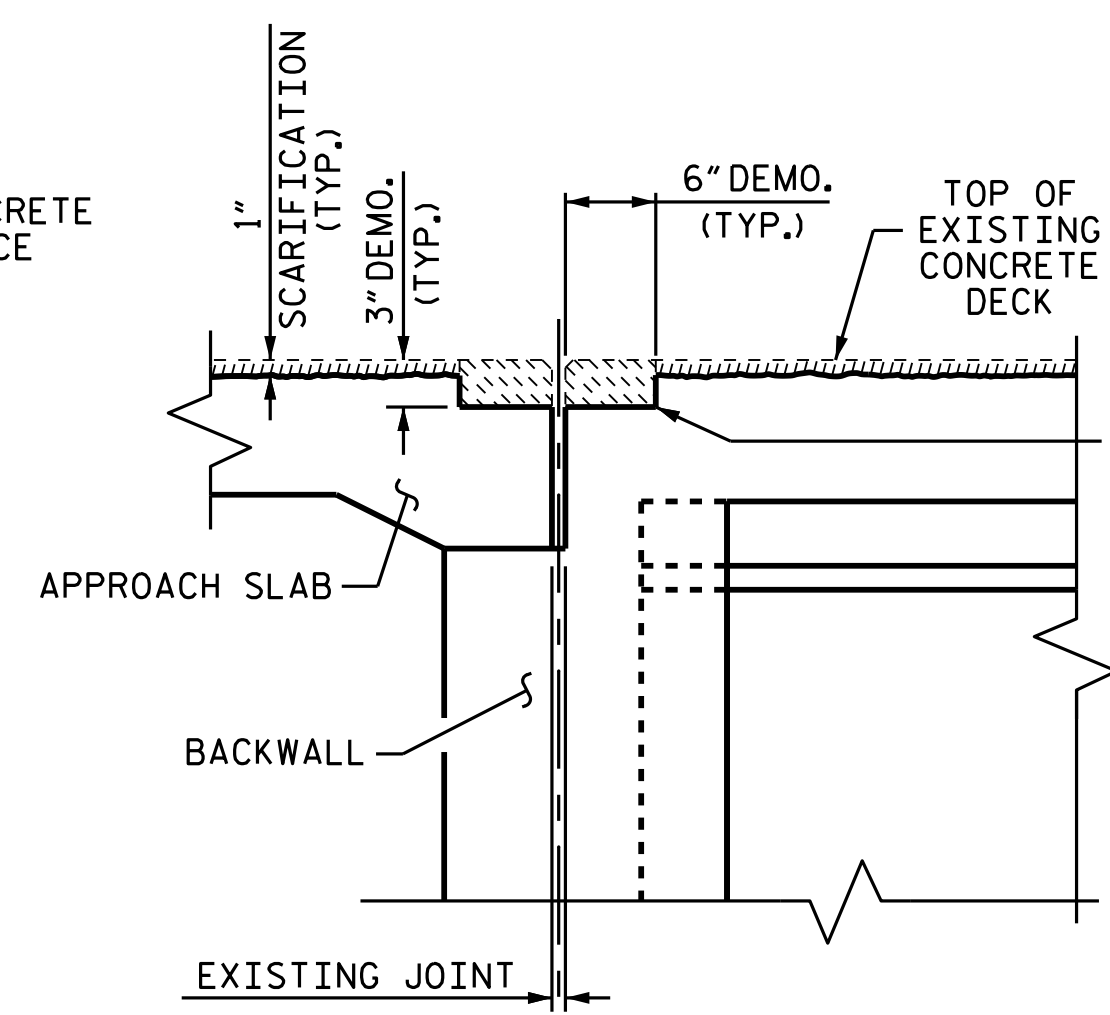

MINIMUM EXISTING JOINT DEMOLITION & SCARIFICATION

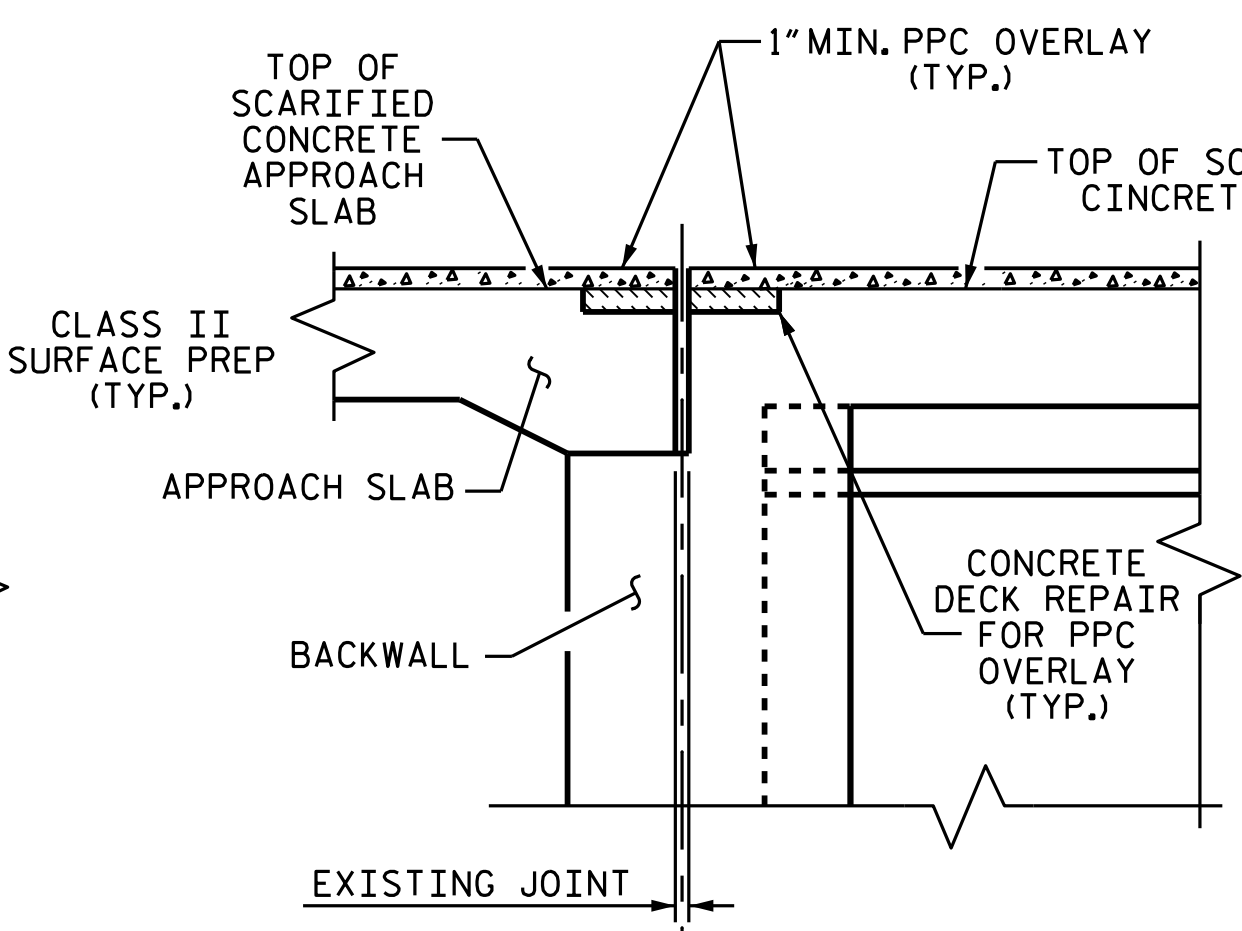

PROPOSED JOINT PRE-SAWED & PPC OVERLAY

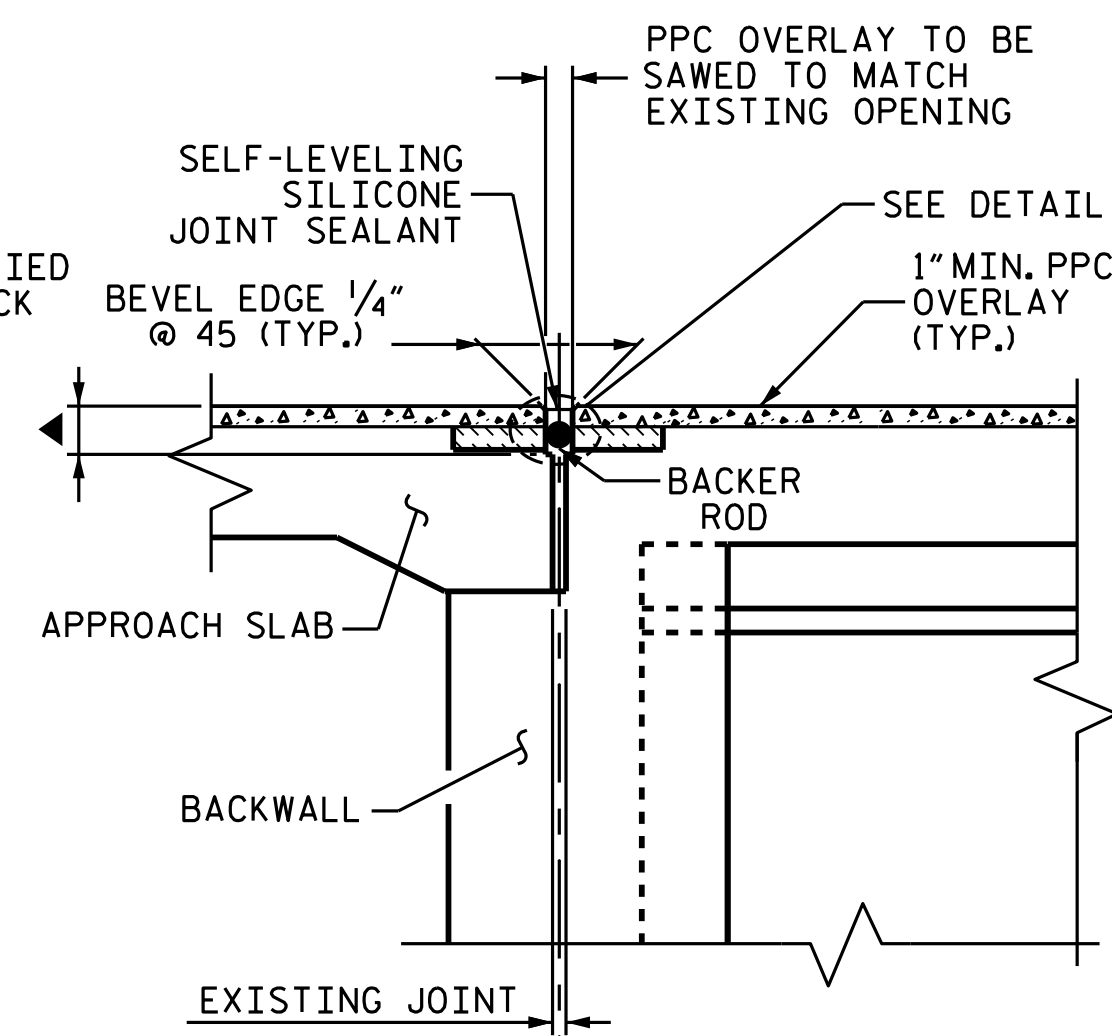

PROPOSED JOINT WITH SAWED DIMENSIONS

JOINT INSTALLATION SEQUENCE AT END BENTS

SECTION A-A

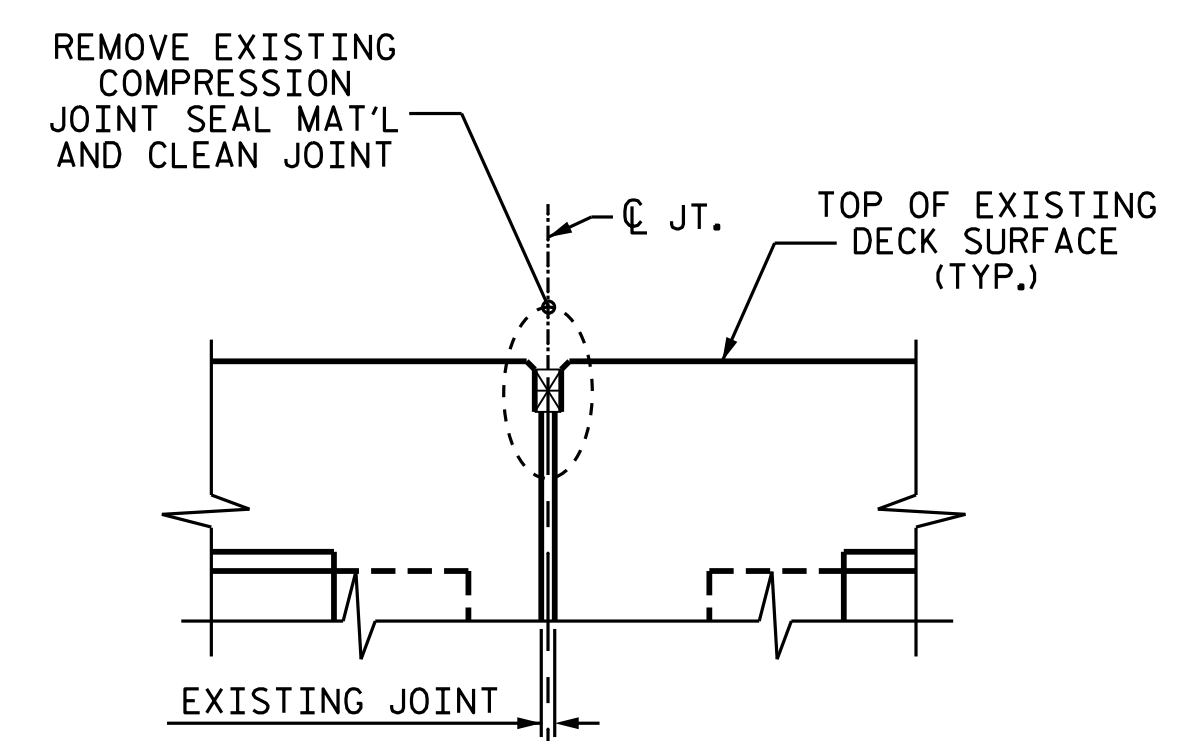

EXISTING COMPRESSION JOINT SEAL

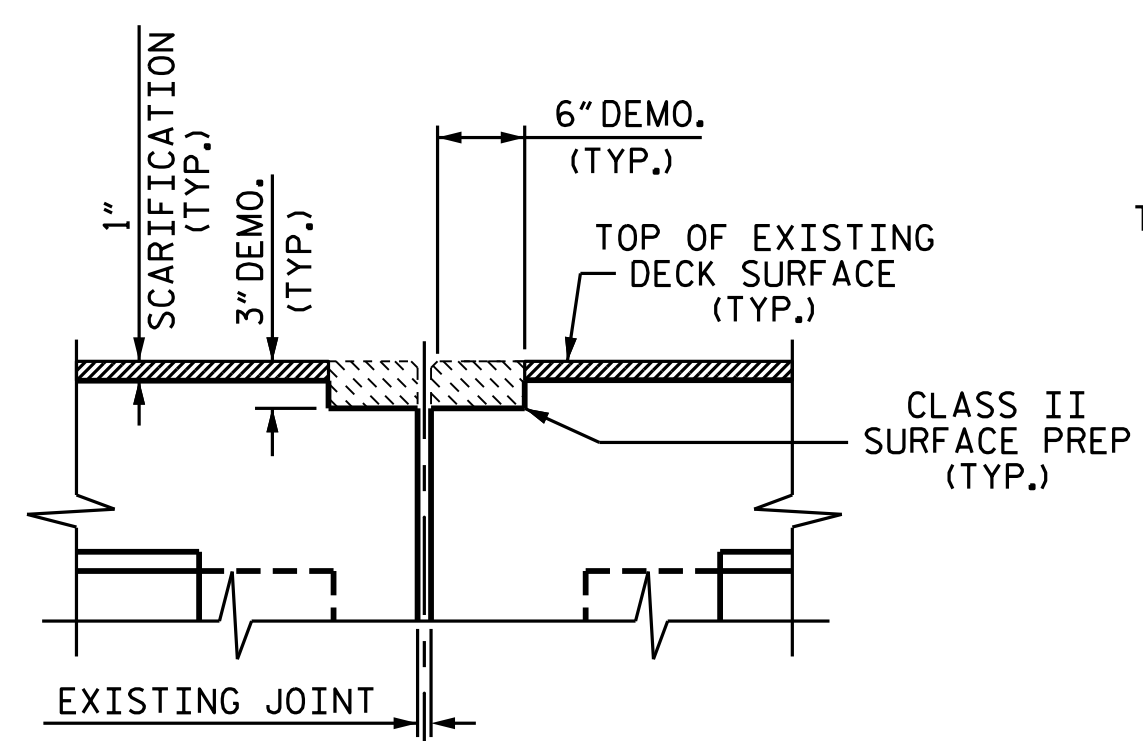

MINIMUM EXISTING JOINT DEMOLITION AND SCARIFICATION

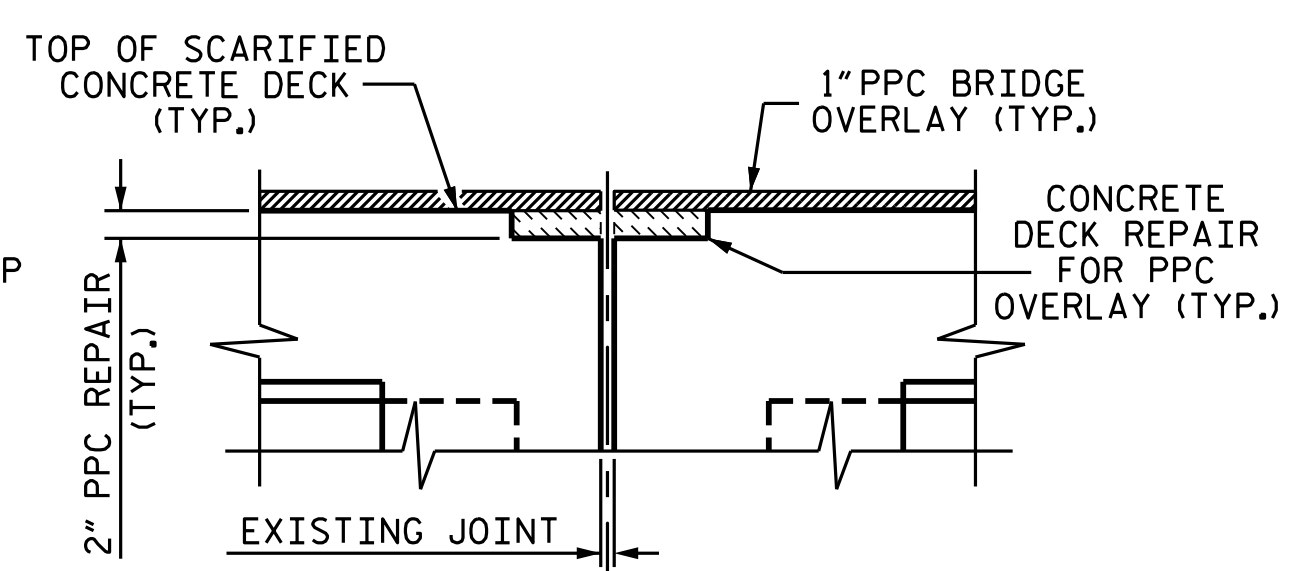

PROPOSED JOINT PRE-SAWED AND PPC OVERLAY

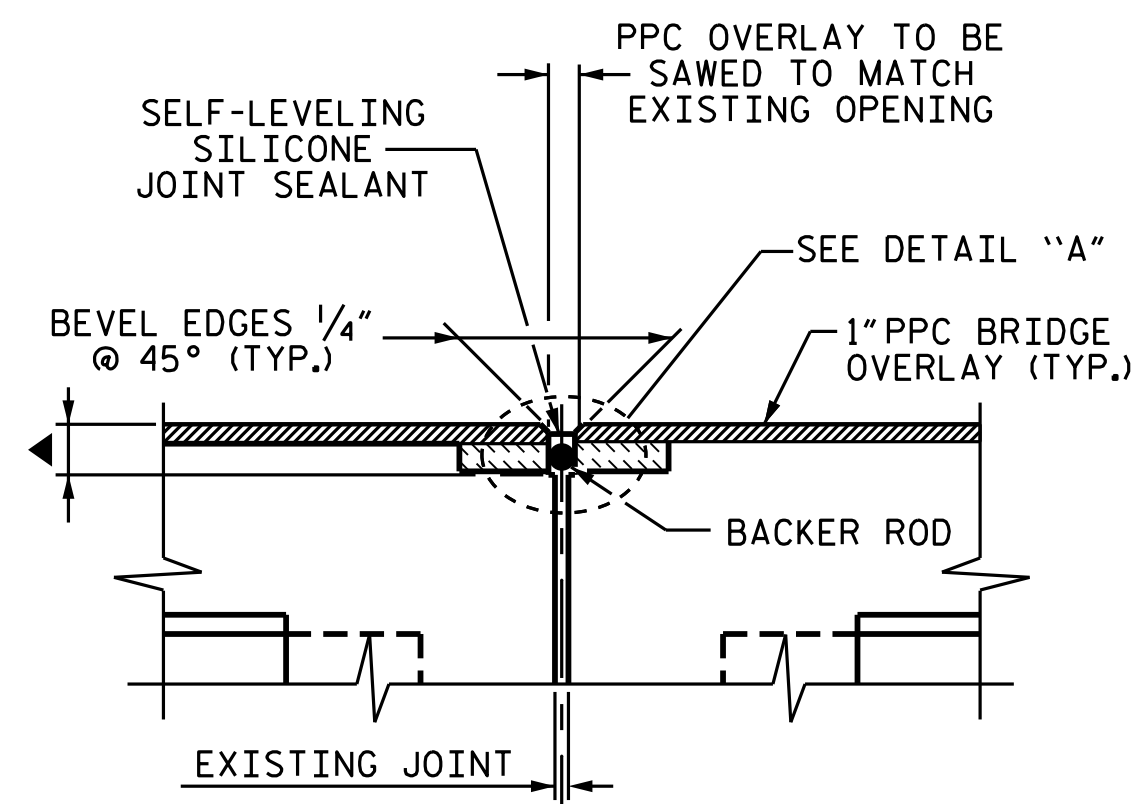

PROPOSED JOINT WITH SAWED DIMENSIONS

▲ SAW CUT SHALL BE 3/4" BELOW THE BOTTOM OF THE JOINT SEAL. SEE MANUFACTURER RECOMMENDATIONS

JOINT INSTALLATION SEQUENCE AT BENTS

SECTION B-B

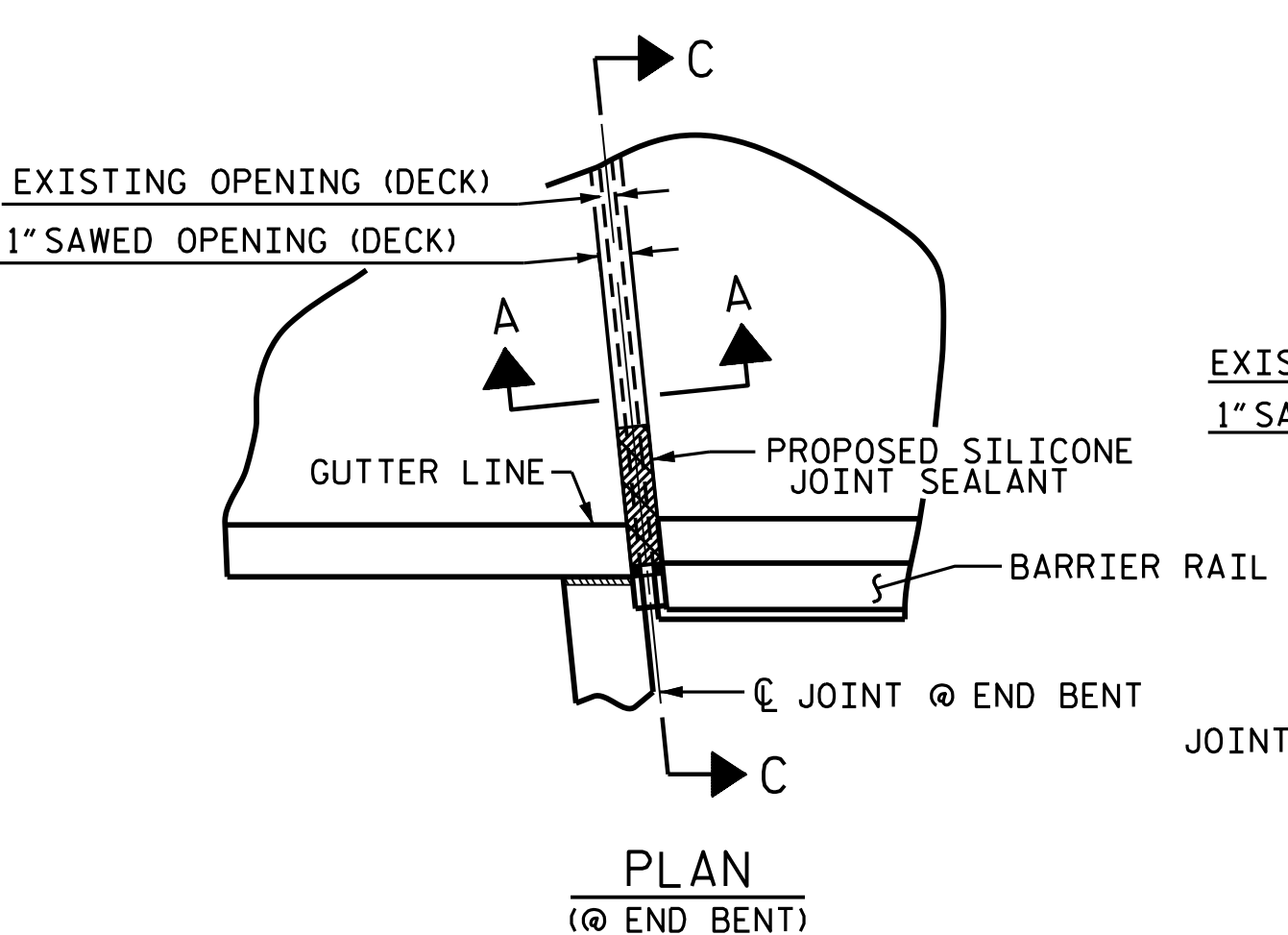

PLAN (@ END BENT)

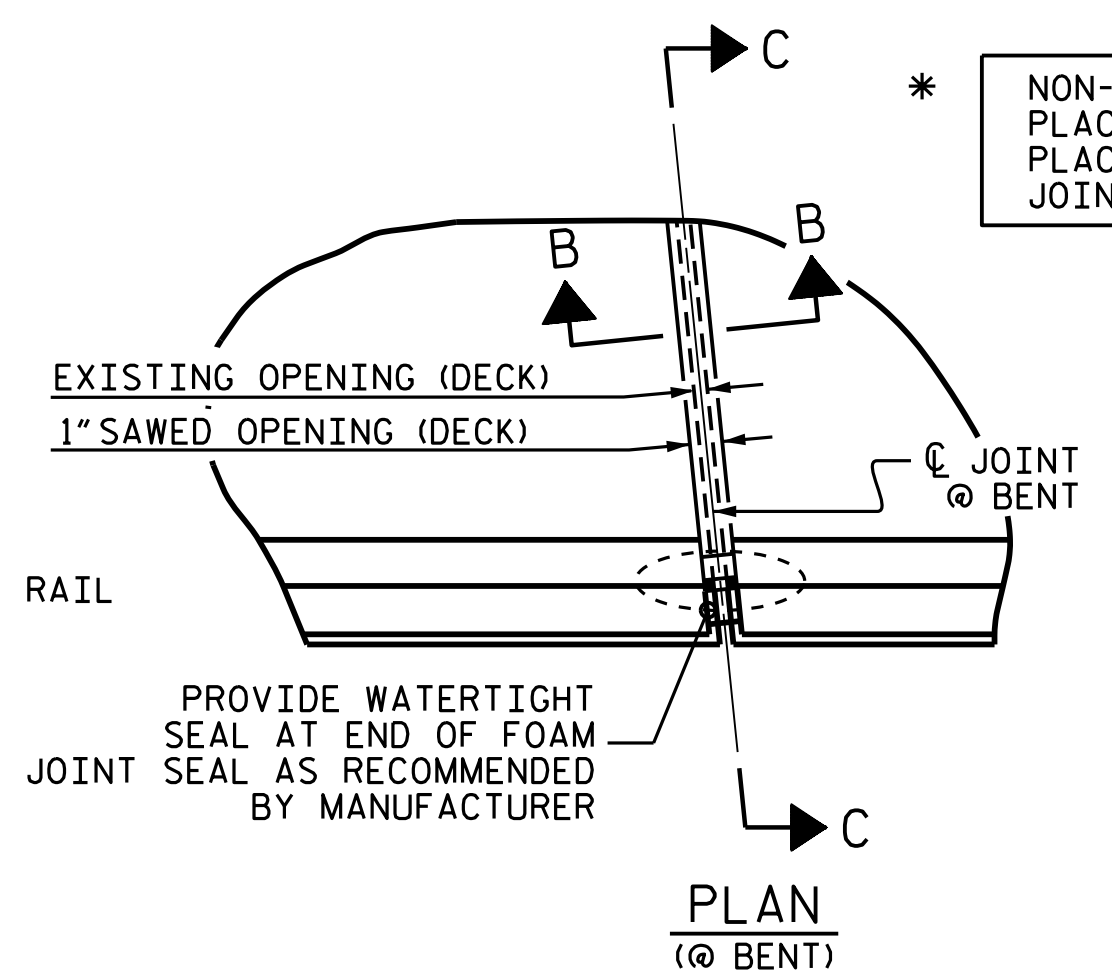

PLAN (@ BENT)

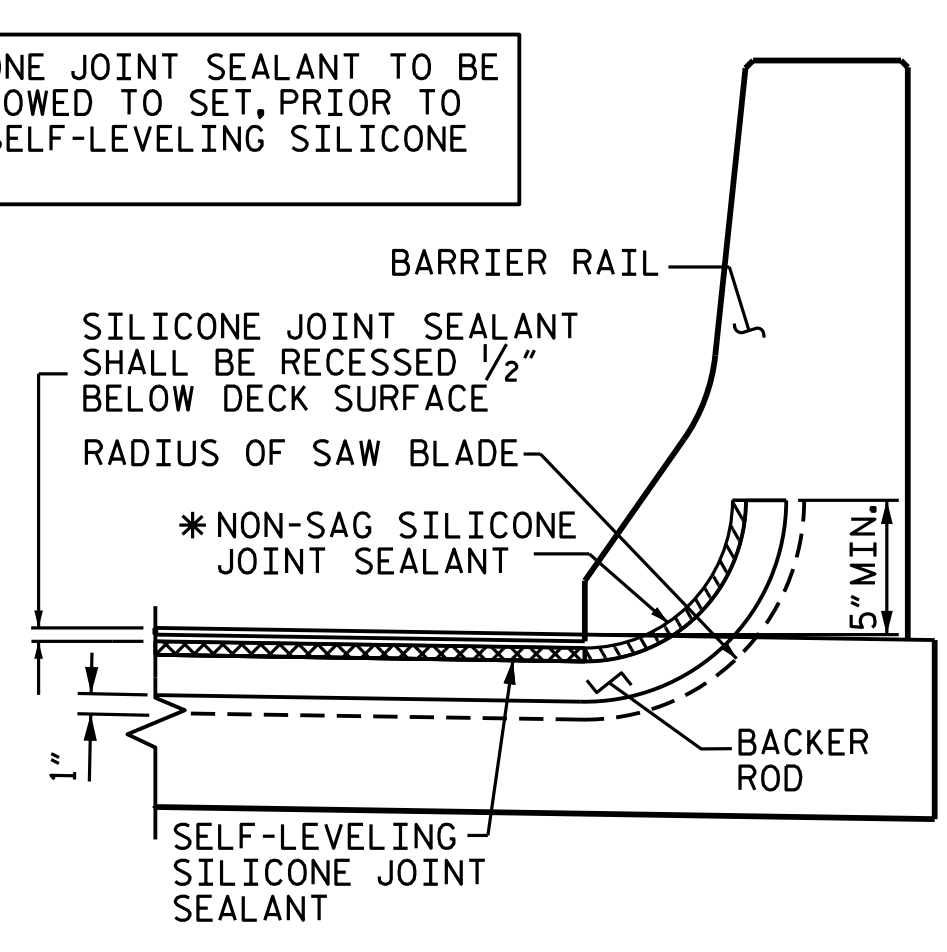

SECTION C-C

\* NON-SAG SILICONE JOINT SEALANT TO BE PLACED AND ALLOWED TO SET, PRIOR TO PLACEMENT OF SELF-LEVELING SILICONE JOINT SEALANT.

PROVIDE WATERTIGHT SEAL AT END OF FOAM SEAL AS RECOMMENDED BY MANUFACTURER

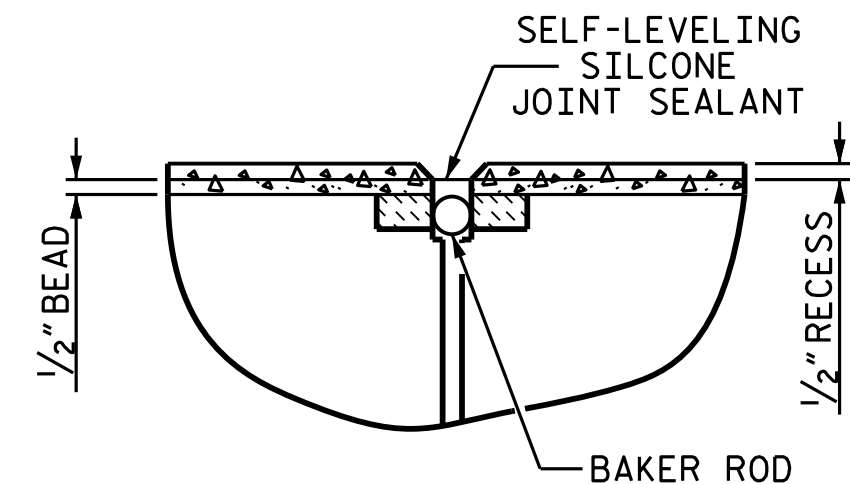

DETAIL A

JOINT REPAIR QUANTITY TABLE

	CLASS II SURFACE PREPARATION	CONCRETE DECK REPAIR FOR PPC OVERLAY
END BENT 1	6.3 SY	6.3 SY
BENT 1	6.3 SY	6.3 SY
BENT 2	6.3 SY	6.3 SY
END BENT 2	6.3 SY	6.3 SY
* TOTAL	25.2 SY	25.2 SY

\* BASED ON THE MINIMUM BLOCKOUT SHOWN.

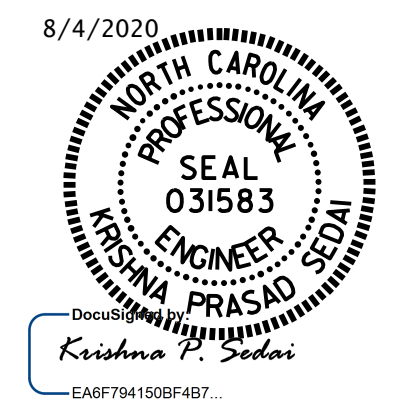

NOTE

THE CONTRACTOR SHALL FIELD VERIFY THE EXISTING JOINT OPENING PRIOR TO ORDERING JOINT SEAL MATERIAL. IF ACTUAL JOINT OPENING VARIES FROM THE OPENING INDICATED IN DETAIL BY MORE THAN 1/4", NOTIFY ENGINEER. REVISION TO THE JOINT SEAL SIZE MIGHT BE NECESSARY.

FINAL JOINT SEALS SHALL NOT BE INSTALLED UNTIL THE OVERLAY IS COMPLETE.

THE CONTRACTOR SHALL TAKE CARE DURING JOINT REHAB OPERATIONS NOT TO DROP ANY MATERIAL BELOW THE BRIDGE WITHOUT PROTECTIVE DEVICES BELOW TO CATCH THE MATERIAL. ANY MATERIAL THAT FALLS BELOW THE BRIDGE SHALL BE CONTAINED, REMOVED AND DISPOSED OF BY THE CONTRACTOR AT NO EXTRA COST TO THE DEPARTMENT. IF THE ENGINEER DETERMINES THAT THE PROTECTIVE DEVICES ARE NOT ADEQUATE OR NOT BEING EMPLOYED, THE WORK SHALL BE SUSPENDED UNTIL ADEQUATE PROTECTION IS PROVIDED.

THE CONTRACTOR WILL NOT BE PERMITTED TO FORM THE JOINTS IN LIEU OF SAWING THE JOINT.

DURING THE JOINT INSTALLATION PROCEDURE, THE JOINT AND SURROUNDING AREA SHALL BE KEPT CLEAN AND FREE OF DEBRIS.

FOR POURABLE SILICONE JOINT SEALANT, SEE SPECIAL PROVISIONS.

THE MANUFACTURER IS TO PROVIDE THE NOMINAL UNCOMPRESSED SEAL WIDTH OF THE BACKER ROD FOR THE EXISTING JOINT SIZE AND ACCOMMODATE THE MINIMUM EXPANSION SHOWN ON THE PLANS.

A MANUFACTURER'S CERTIFIED TRAINED REPRESENTATIVE SHALL BE PRESENT DURING THE INSTALLATION OF THE FIRST JOINT OF THE PROJECT, OR UNTIL THE ENGINEER IS SATISFIED WITH THE INSTALLATION PROCESS.

THE INSTALLATION OF THE JOINT SEAL SHALL BE WATERTIGHT.

FINAL SURFACE OF THE JOINT DEMOLITION AREA PRIOR TO PLACEMENT OF CONCRETE REPAIR MATERIAL SHOULD BE REASONABLY FLAT AND LEVEL. ENGINEER SHALL DETERMINE THE ACCEPTABILITY OF THE SURFACE PRIOR TO PLACEMENT OF REPAIR CONCRETE.

JOINT REPAIR QUANTITY TABLE		
	ESTIMATE	ACTUAL
POURABLE SILICONE JOINT SEALANT		
END BENT 1	58.2 LF	
BENT 1	58.2 LF	
BENT 2	58.2 LF	
END BENT 2	58.2 LF	
TOTAL	232.8 LF	

PROJECT NO. I-5795  
 FORSYTH COUNTY  
 BRIDGE NO. 330479

STATE OF NORTH CAROLINA  
 DEPARTMENT OF TRANSPORTATION  
 RALEIGH

JOINT DETAILS

DRAWN BY: A. SORSENGINH DATE: 1/2020  
 CHECKED BY: K. PUROHIT DATE: 4/2020

DOCUMENT NOT CONSIDERED FINAL UNLESS ALL SIGNATURES COMPLETED

REVISIONS						SHEET NO.
NO.	BY:	DATE:	NO.	BY:	DATE:	
1			3			S7-04
2			4			TOTAL SHEETS 7