

NOTES:
 FOR "SECTION A-A" AND "SECTION B-B", SEE SHEET 3 OF 3.
 FOR "VIEW X-X", SEE SHEET 3 OF 3
 FOR NOTES, SEE SHEET 3 OF 3.

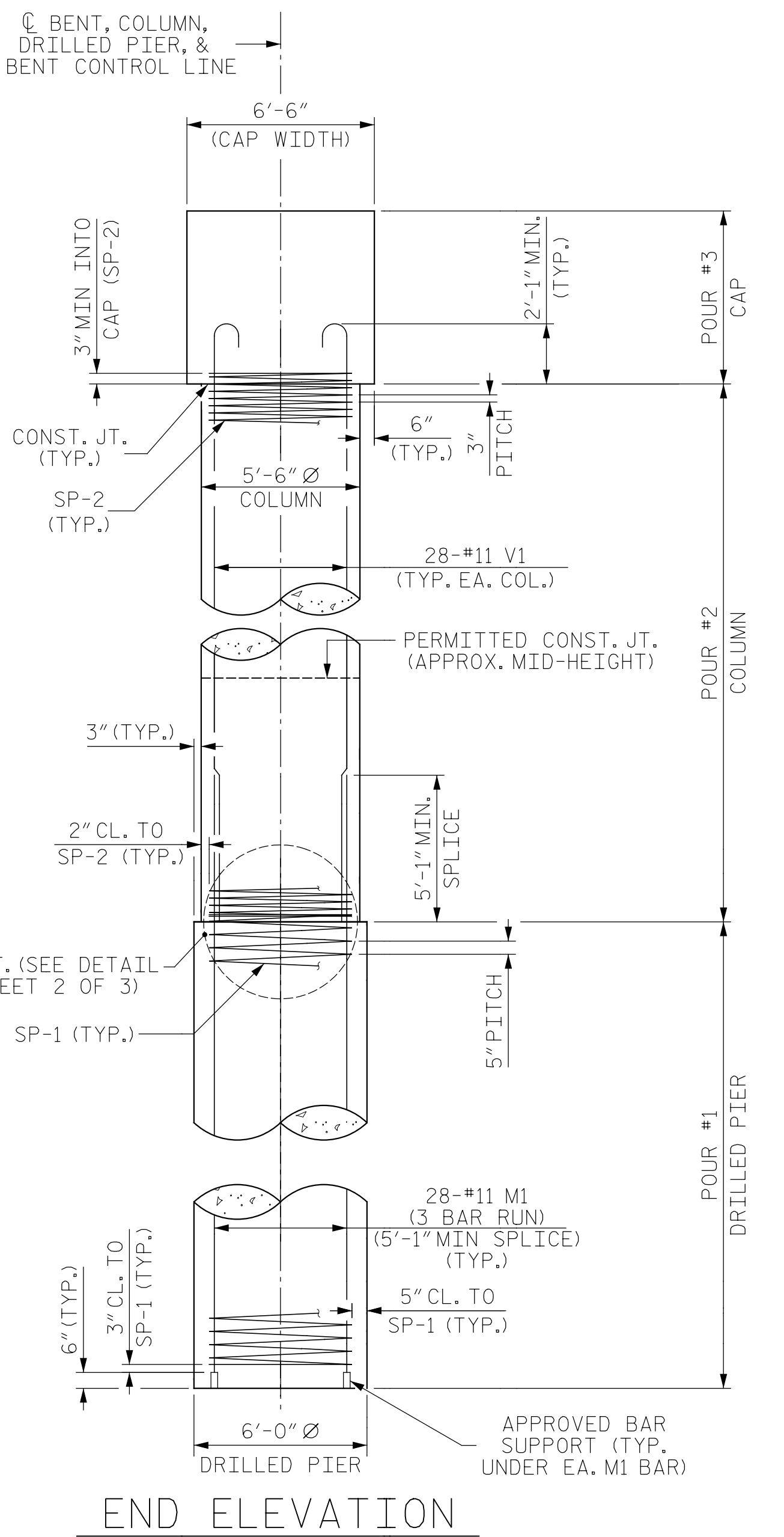

- ▲ MIN. PROJECTION (TYP.)
- TYP. @ EACH BRIDGE SEAT
- ① 2-#4 U1 @ 1'-6" (TYP.)

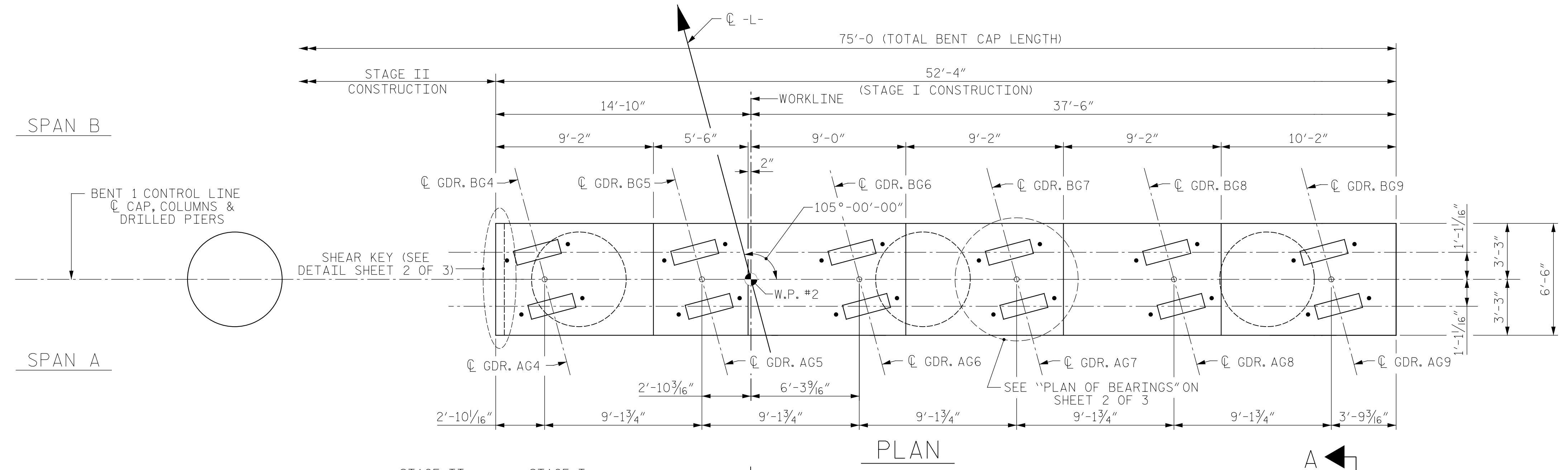
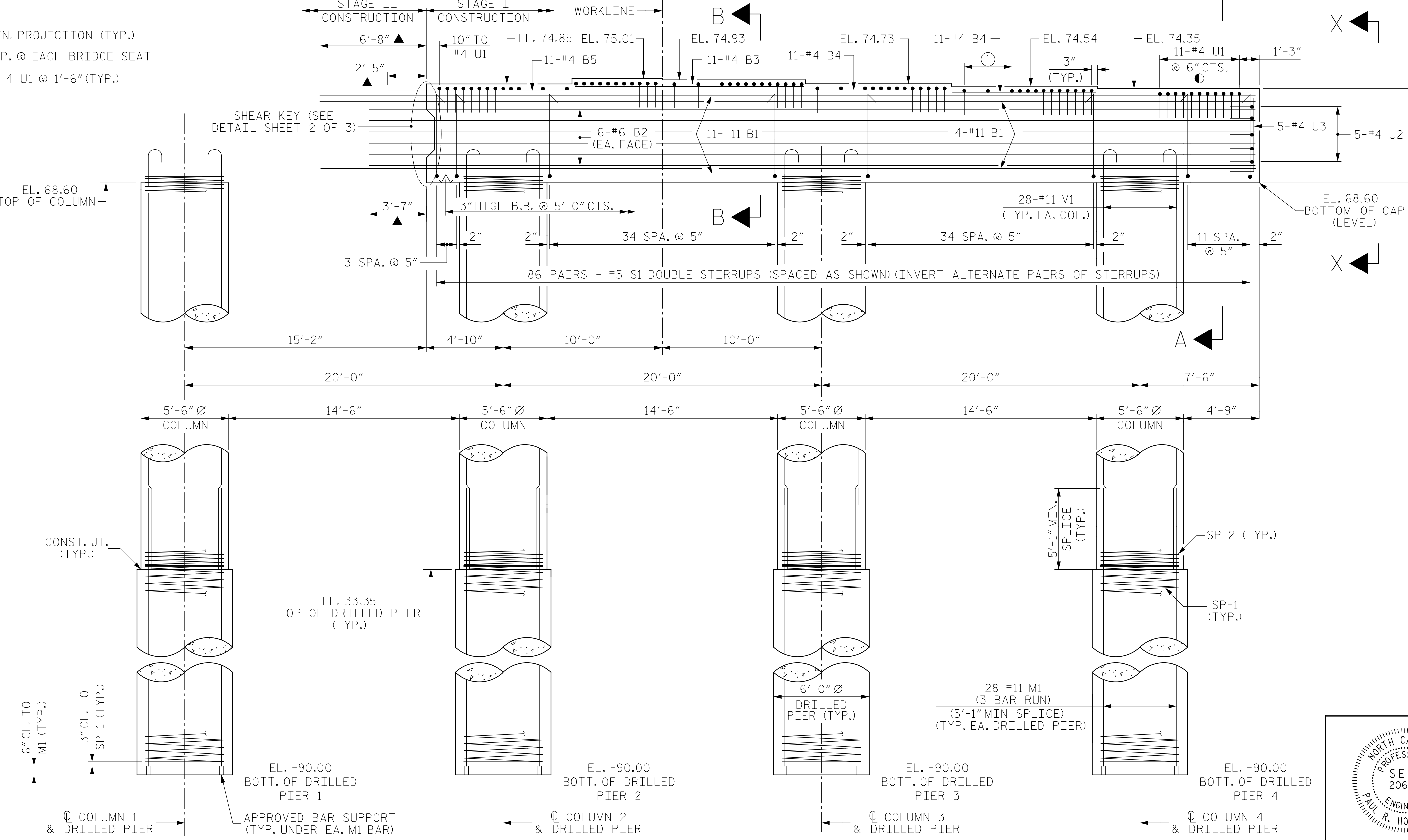

Pen Table: \\192.168.64.12\icardu\RDUCAD\Plotting\Pen Tables\ICE.NC.Struct.tbl
 Print Driver: \\192.168.64.12\icardu\RDUCAD\Plotting\NGD0T\22x34_PDF_ICE.pltcfq
 User name: jmaustfn
 File name: R:\Projects\19-77 Division 6 On Call\02 US 701 over Cape Fear River\NCDDT\Structures\Dwgs\Final\401-073_US_701_SWL-BT1-01.dgn
 Plot head: 8/11/2020 10:09:33 PM
 User: R:\Projects\19-77 Division 6 On Call\02 US 701 over Cape Fear River\NCDDT\Structures\Dwgs\Final\401-073_US_701_SWL-BT1-01.dgn

PROJECT NO. 48793.3.1
 BLADEN COUNTY
 STATION: 118+81.78 -L-
 SHEET 1 OF 3

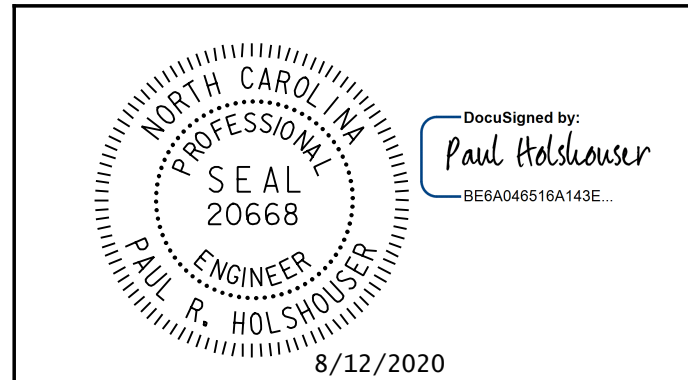

DRAWN BY : B. J. MANTEI DATE : 5-17-20
 CHECKED BY : N. D'AIUTO DATE : 7-17-20
 DESIGN E.O.R. : P. R. HOLSHOUSER DATE : 7-23-20

ALL DIMENSIONS AND DETAILS SHOWN FOR DRILLED PIERS ARE TYPICAL FOR EACH PIER UNLESS OTHERWISE NOTED.

DOCUMENT NOT CONSIDERED FINAL UNLESS ALL SIGNATURES COMPLETED

ICE of Carolinas, PLLC 4505 Falls of Neuse Road, Suite 110 Raleigh, North Carolina 27609 Phone: 919-822-0333 License #: P-0999						SHEET NO. S-73 TOTAL SHEETS 107	
REVISIONS NO. BY: DATE: NO. BY: DATE:				REVISIONS NO. BY: DATE: NO. BY: DATE:			
1				3			
2				4			