

PLAN OF SPAN A AND PARTIAL PLAN OF SPAN B

2 BR DENOTES 2 BAR RUN.  
 3 BR DENOTES 3 BAR RUN.  
 \* (TYP. EA. STAGE)  
 Δ TOP OF SLAB

NOTES

FOR CLOSURE POUR DETAILS, SEE "PLAN OF SPAN DETAILS", SHEET 7 OF 8 & "TYPICAL SECTION" SHEET 3 OF 6.  
 FOR POUR SEQUENCE, SEE "POURING SEQUENCE" SHEETS.  
 FOR BENT/END BENT DIAPHRAGM DETAILS & REINFORCING STEEL, SEE SHEETS 7 OF 8 & 8 OF 8.  
 LONGITUDINAL STEEL MAY BE SHIFTED SLIGHTLY TO CLEAR DECK DRAINS.  
 FOR TRANSVERSE CONSTRUCTION JOINT DETAIL, SEE SHEET 4 OF 8.

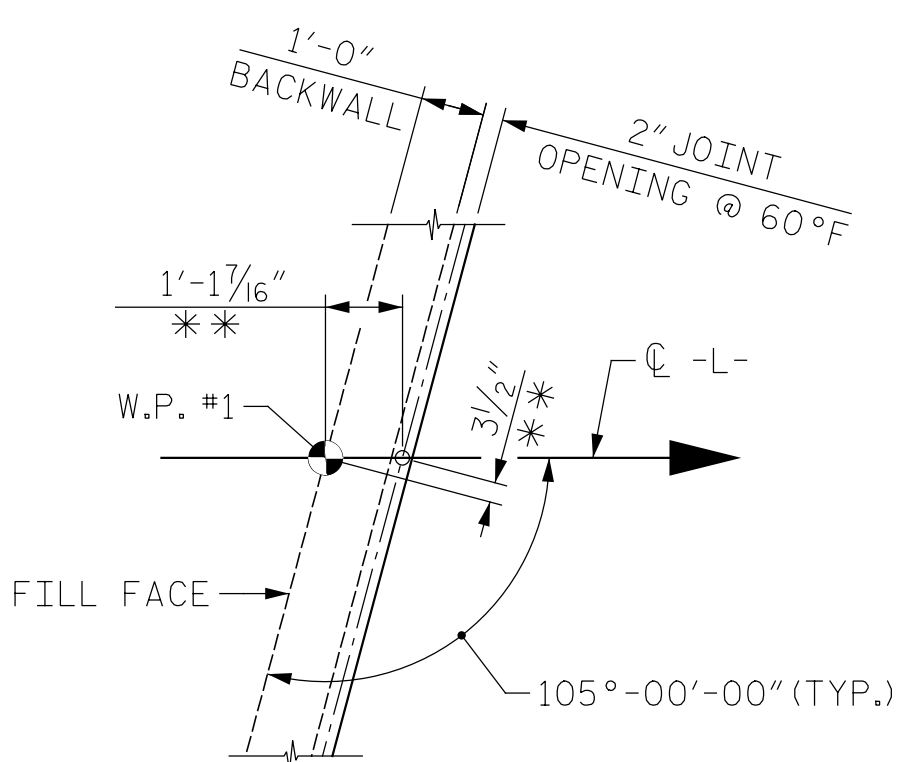

DETAIL A  
 \*\* W.P. TO CL JOINT

- (A) #5 A101 THRU #5 A111 @ 6 1/2" CTS. (2 BARS PER MARK) (TOP OF SLAB)
- (B) #5 A201 THRU #5 A211 @ 6 1/2" CTS. (2 BARS PER MARK) (BOT. OF SLAB)
- (C) 6-#5 B9 @ 11" CTS. (BOT. OF SLAB) (TYP. BAYS 4-8) (8 BAR RUN) (2'-0" MIN. SPLICE)
- (D) 5-#5 B10 @ 11" CTS. (BOT. OF SLAB) (TYP. BAYS 4-8)
- (E) #5 A301 THRU #5 A304 @ 6 1/2" CTS. (2 BARS PER MARK) (TOP OF SLAB)
- (F) #5 A401 THRU #5 A404 @ 6 1/2" CTS. (2 BARS PER MARK) (BOT. OF SLAB)
- (G) 15-#5 B1 @ 1'-4" CTS. (TOP OF SLAB) (2 BR)
- (H) 5-#5 B9 @ 9 1/2" CTS. (TYP. BAYS 1-2) (BOT. OF SLAB) (8 BAR RUN) (2'-0" MIN. SPLICE)
- (I) 4-#5 B10 @ 9 1/2" CTS. (BOT. OF SLAB) (TYP. BAYS 1-2)
- (J) 4-#5 B9 @ 7" CTS. (8 BAR RUN) (BOT. OF SLAB) (2'-0" MIN. SPLICE)
- (K) 3-#5 B1 @ 1'-4" MAX. CTS. (2 BAR RUN) (TOP OF SLAB)
- (L) 3-#6 B7 (3 BAR RUN) (TOP OF SLAB) (SEE CLOSURE POUR DETAILS)
- (M) 6-#6 B8 (TOP OF SLAB) (SEE CLOSURE POUR DETAILS) (STAGGERED)
- (N) 42-#6 B8 (TOP OF SLAB) (3 @ 4" CTS.) (SPACED BETWEEN #6 B7 BARS) (STAGGERED)

DRAWN BY : N.D. AIUTO DATE : 7-15-20  
 CHECKED BY : N. REZAEI DATE : 7-21-20  
 DESIGN E.O.R. : P. R. HOLSHOUSER DATE : 7-23-20

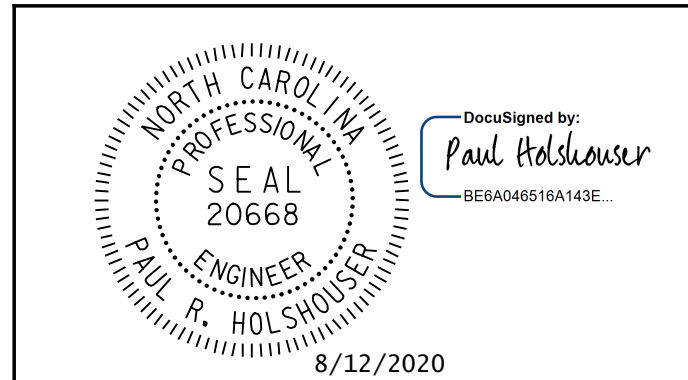

ICE of Carolinas, PLLC  
 4505 Falls of Neuse Road, Suite 110  
 Raleigh, North Carolina 27609  
 Phone: 803-822-0333  
 License #: P-0999

PROJECT NO. 48793.3.1  
 BLADEN COUNTY  
 STATION: 118+81.78 -L-  
 SHEET 1 OF 8

STATE OF NORTH CAROLINA DEPARTMENT OF TRANSPORTATION RALEIGH					
SUPERSTRUCTURE					
PLAN OF SPANS UNIT 1					
SPANS A & B					
REVISIONS					
NO.	BY:	DATE:	NO.	BY:	DATE:
1			3		
2			4		
SHEET NO. S-17					TOTAL SHEETS 107

DOCUMENT NOT CONSIDERED FINAL  
 UNLESS ALL SIGNATURES COMPLETED

Pen Table: \\192.168.64.12\ice\rd\RDUCAD\Plotting\Pen Tables\ICE\_NC\_S\struct.tbl  
 Print Driver: \\192.168.64.12\ice\rd\RDUCAD\Plotting\NGD0T\22x34\_PDF-ICE.pltcfq  
 User: jmaustfn  
 File: R:\Projects\19-77 Division 6 On Call\02 US 701 over Cape Fear River\NCDOT\Structures\Dwgs\Final\401-017-US-701-SMU-PS-01.dgn  
 Plot Date: 8/11/2020 10:07:48 PM