

STATE OF NORTH CAROLINA
DIVISION OF HIGHWAYS

TRANSPORTATION MANAGEMENT PLAN

ALAMANCE COUNTY

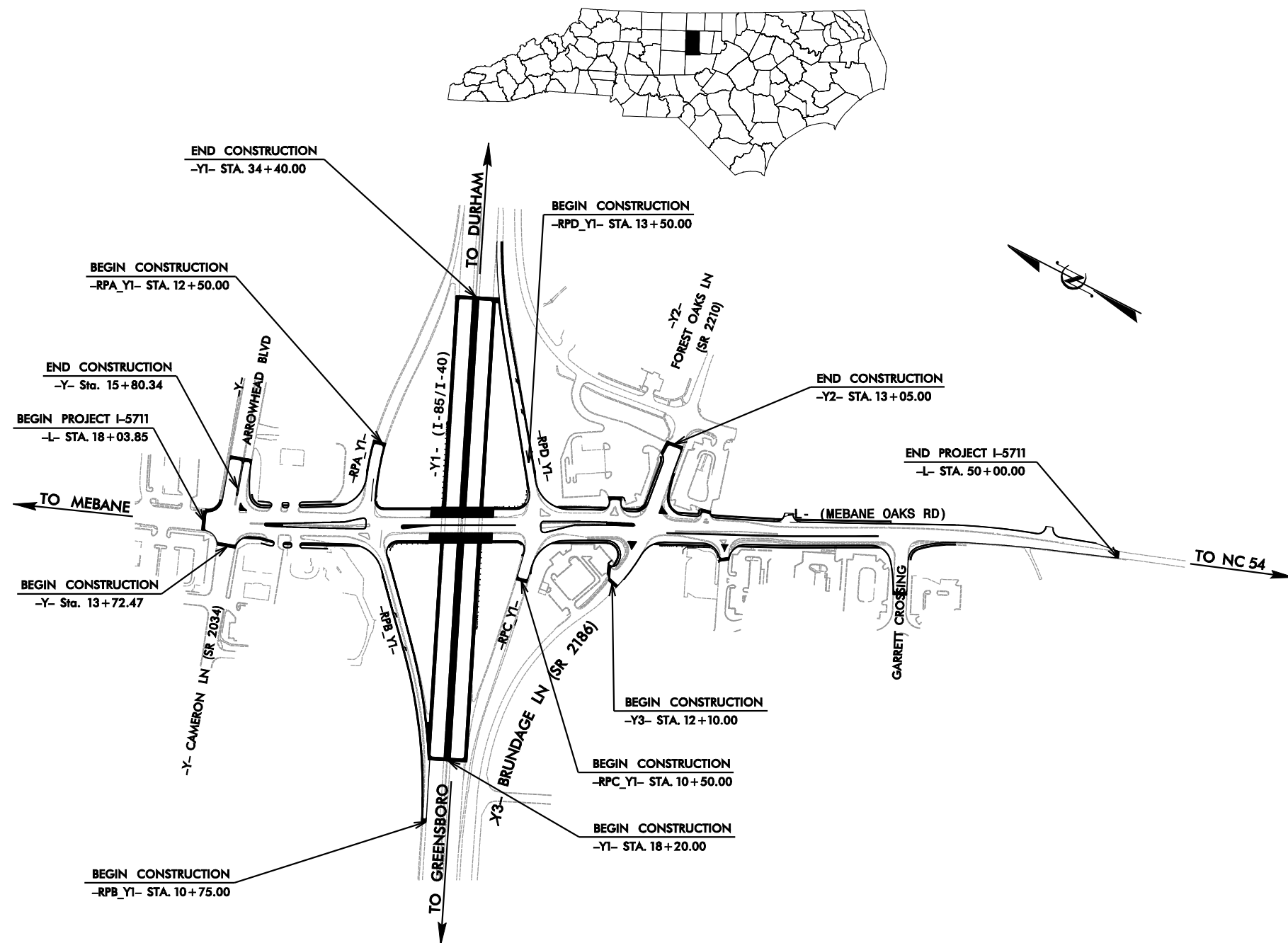

INDEX OF SHEETS

SHEET NO.	TITLE
TMP-1	TITLE SHEET, VICINITY MAP AND INDEX OF SHEETS
TMP-1A	LIST OF APPLICABLE ROADWAY STANDARD DRAWINGS AND LEGEND
TMP-1B AND TMP-1C	TRANSPORTATION OPERATIONS PLAN
TMP-1D	PCB TYPICAL
TMP-2	-Y1- OFFSITE DETOUR ROUTE
TMP-2A	PORTABLE CONCRETE BARRIER AT TEMPORARY SHORING LOCATIONS
TMP-2B	TEMPORARY SHORING DATA
TMP-3 AND TMP-3A	PROJECT PHASING
TMP-4	PHASE IA OVERVIEW
TMP-4A THRU TMP-4D	PHASE IA DETAILS
TMP-5	PHASE IB OVERVIEW
TMP-5A THRU TMP-5C	PHASE IB DETAILS
TMP-5D	PHASE IC DETAILS
TMP-6	PHASE II OVERVIEW
TMP-6A THRU TMP-6B	PHASE II DETAILS
TMP-6C THRU TMP-6D	PHASE IIA DETAILS
TMP-7	PHASE III OVERVIEW
TMP-7A THRU TMP-7B	PHASE III DETAILS
TMP-7C THRU TMP-7D	PHASE III DETAILS, STEPS 5-7
TMP-8 AND TMP-8A	TEMPORARY TRAFFIC CONTROL CROSS SECTIONS

SHEET NO.
TMP-1

I-571I

TIP PROJECT:



PLANS PREPARED BY:

TIM AREY, P.E.

NCDOT CONTACTS:

KENNETH C. THORNEWELL P.E.
PROJECT ENGINEER

MIKE STEELMAN
PROJECT DESIGN ENGINEER

DOCUMENT NOT CONSIDERED FINAL
UNLESS ALL SIGNATURES COMPLETED

Prepared In the Office of:
PROGRESSIVE
DESIGN GROUP, INC.
ENGINEERS • CONSULTANTS

APPROVED: Tim Arey
DATE: 2/26/2020

SEAL

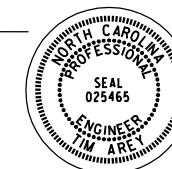

ROADWAY STANDARD DRAWINGS

THE FOLLOWING ROADWAY STANDARDS AS SHOWN IN "ROADWAY STANDARD DRAWINGS" - N.C. DEPARTMENT OF TRANSPORTATION - RALEIGH, N.C., DATED JANUARY 2018 ARE APPLICABLE TO THIS PROJECT AND BY REFERENCE HEREBY ARE CONSIDERED A PART OF THESE PLANS:

STD. NO.	TITLE
1101.01	WORK ZONE ADVANCE WARNING SIGNS
1101.02	TEMPORARY LANE CLOSURES
1101.03	TEMPORARY ROAD CLOSURES
1101.04	TEMPORARY SHOULDER CLOSURES
1101.05	WORK ZONE VEHICLE ACCESSES
1101.11	TRAFFIC CONTROL DESIGN TABLES
1110.01	STATIONARY WORK ZONE SIGNS
1110.02	PORTABLE WORK ZONE SIGNS
1115.01	FLASHING ARROW BOARDS
1130.01	DRUM
1135.01	CONES
1145.01	BARRICADES
1150.01	FLAGGING DEVICES
1160.01	TEMPORARY CRASH CUSHION
1165.01	WORK VEHICLE LIGHTING SYSTEMS AND TMA DELINEATION
1170.01	POSITIVE PROTECTION
1180.01	SKINNY-DRUM
1205.01	PAVEMENT MARKINGS - LINE TYPES AND OFFSETS
1205.02	PAVEMENT MARKINGS - TWO-LANE AND MULTI-LANE ROADWAYS
1205.03	PAVEMENT MARKINGS - EXITS AND ENTRANCE RAMP
1205.04	PAVEMENT MARKINGS - INTERSECTIONS
1205.05	PAVEMENT MARKINGS - TURN LANES
1205.06	PAVEMENT MARKINGS - LANE DROPS
1205.07	PAVEMENT MARKINGS - PEDESTRIAN CROSSWALKS
1205.08	PAVEMENT MARKINGS - SYMBOLS AND WORD MESSAGES
1205.09	PAVEMENT MARKINGS - PAINTED ISLANDS
1205.12	PAVEMENT MARKINGS - BRIDGES
1205.13	PAVEMENT MARKINGS - LANE REDUCTIONS
1250.01	RAISED PAVEMENT MARKERS - INSTALLATION SPACING
1251.01	RAISED PAVEMENT MARKERS - PERMANENT AND TEMPORARY
1261.01	GUARDRAIL AND BARRIER DELINEATORS - INSTALLATION SPACING
1261.02	GUARDRAIL AND BARRIER DELINEATORS - TYPES AND MOUNTING
1262.01	GUARDRAIL END DELINEATION

LEGEND

GENERAL

- DIRECTION OF TRAFFIC FLOW
- DIRECTION OF PEDESTRIAN TRAFFIC FLOW
- EXIST. PVMT.
- NORTH ARROW
- PROPOSED PVMT.
- TEMP. SHORING (LOCATION PURPOSES ONLY)

- WORK AREA
- ON-GOING CONSTRUCTION
- REMOVAL
- WORK AREA WITH A DELAY OF ENTRY (SEE SPECIAL PROVISIONS)

SIGNALS

- EXISTING
- PROPOSED
- TEMPORARY

PAVEMENT MARKINGS

- EXISTING LINES
- TEMPORARY LINES

TRAFFIC CONTROL DEVICES

- BARRICADE (TYPE III)
- CONE
- DRUM SKINNY DRUM TUBULAR MARKER
- TEMPORARY CRASH CUSHION
- FLASHING ARROW BOARD
- FLAGGER
- LAW ENFORCEMENT
- TRUCK MOUNTED ATTENUATOR (TMA)
- CHANGEABLE MESSAGE SIGN

TEMPORARY SIGNING

- PORTABLE SIGN
- STATIONARY SIGN
- STATIONARY OR PORTABLE SIGN

PAVEMENT MARKERS

- CRYSTAL/CRYSTAL
- CRYSTAL/RED
- YELLOW/YELLOW

PAVEMENT MARKING SYMBOLS

- PAVEMENT MARKING SYMBOLS

TEMPORARY PAVEMENT MARKING SCHEDULE

PAVEMENT MARKINGS PAINT(4")

- PA WHITE EDGELINE
- PB YELLOW EDGELINE
- PC 10 FT. WHITE SKIP
- PD 3 FT. - 9 FT./SP WHITE MINISKIP
- PE WHITE SOLID LANE LINE
- PI YELLOW DOUBLE CENTER

PAVEMENT MARKINGS PAINT(6")

- P6 WHITE EDGELINE
- P7 YELLOW EDGELINE
- PJ 10 FT. WHITE SKIP
- PK 3 FT. - 9 FT./SP WHITE MINISKIP

PAVEMENT MARKINGS PAINT(8")

- PN WHITE GORELINE
- PQ WHITE CROSSWALK LINE

PAVEMENT MARKINGS PAINT(12")

- PS WHITE GORELINE
- QM YIELD LINE TRIANGLE

PAVEMENT MARKINGS PAINT(24")

- P2 WHITE STOPBAR

PAVEMENT MARKING SYMBOLS (PAINT)

- QA LEFT TURN ARROW
- QB RIGHT TURN ARROW
- QC STRAIGHT ARROW
- QE COMBO. STRAIGHT/RIGHT ARROW
- QI ALPHANUMERIC CHARACTER
- QP MERGE ARROW

PAVEMENT MARKINGS COLD APPLIED PLASTIC TAPE(4")

- CC 10 FT. WHITE SKIP
- CD 3 FT. - 9 FT./SP WHITE MINISKIP
- CE WHITE SOLID LANE LINE

PAVEMENT MARKING SYMBOLS (COLD APPLIED PLASTIC TAPE)

- DC STRAIGHT ARROW

<p>PLAN PREPARED IN THE OFFICE OF:</p> <p>PROGRESSIVE DESIGN GROUP, INC.</p> <p>ENGINEERS • CONSULTANTS</p>	<p>APPROVED: <i>Tim Arey</i></p> <p>DATE: 2/26/2020</p> <p>SEAL</p>			<p>ROADWAY STANDARD DRAWINGS & LEGEND</p>
	<p>DOCUMENT NOT CONSIDERED FINAL UNLESS ALL SIGNATURES COMPLETED</p>			

PROJECT NOTES

MANAGEMENT STRATEGIES

THE PROJECT WILL BE CONSTRUCTED USING A COMBINATION OF STAGED CONSTRUCTION AND LANE CLOSURES IN ACTIVE ROADWAY LOCATIONS. LANE SHIFTING ALONG I-85 WILL BE UTILIZED FOR CENTER PIER CONSTRUCTION AND ACCESS TO DRIVEWAYS ALONG ALL ROADWAYS ARE TO BE MAINTAINED AT ALL TIMES UNLESS OTHERWISE SHOWN IN THESE PLANS OR DIRECTED BY THE ENGINEER.

GENERAL NOTES

CHANGES MAY BE REQUIRED WHEN PHYSICAL DIMENSIONS IN THE DETAIL DRAWINGS, STANDARD DETAILS, AND ROADWAY DETAILS ARE NOT ATTAINABLE TO MEET FIELD CONDITIONS OR RESULT IN DUPLICATE OR UNDESIRED OVERLAPPING OF DEVICES. MODIFICATION MAY INCLUDE: MOVING, SUPPLEMENTING, COVERING, OR REMOVAL OF DEVICES AS DIRECTED BY THE ENGINEER.

THE FOLLOWING GENERAL NOTES APPLY AT ALL TIMES FOR THE DURATION OF THE CONSTRUCTION PROJECT EXCEPT WHEN OTHERWISE NOTED IN THE PLAN OR DIRECTED BY THE ENGINEER.

TIME RESTRICTIONS

A) DO NOT CLOSE OR NARROW TRAVEL LANES AS FOLLOWS:

ROAD NAME	DAY AND TIME RESTRICTIONS
-Y1- (I-40 / I-85), 1 OF 4 LANES	6:00AM-8:00PM MONDAY THRU SUNDAY
-Y1- (I-40 / I-85), 2 OF 4 LANES	6:00AM-10:00PM MONDAY THRU SUNDAY
-Y1- (I-40 / I-85), 3 OF 4 LANES	6:00AM-MIDNIGHT MONDAY THRU SUNDAY
ALL I-40 / I-85 RAMPS	6:00AM-8:00PM MONDAY THRU SUNDAY
-Y2-, -Y3-	6:00AM-9:00AM, 4:00PM-6:00PM MONDAY THRU FRIDAY
-L- (MEBANE OAKS RD)	6:00AM-9:00AM, 4:00PM-6:00PM MONDAY THRU FRIDAY
	9:00AM-6:00PM SATURDAY AND SUNDAY

B) DO NOT CLOSE OR NARROW TRAVEL LANES DURING HOLIDAYS AND SPECIAL EVENTS AS FOLLOWS:

ROAD NAME

I-40 / I-85, ALL RAMPS, AND -L- UNLESS OTHERWISE NOTED

HOLIDAY

- FOR ANY UNEXPECTED OCCURRENCE THAT CREATES UNUSUALLY HIGH TRAFFIC VOLUMES, AS DIRECTED BY THE ENGINEER.
- FOR NEW YEAR'S, BETWEEN THE HOURS OF 6:00 A.M. DECEMBER 31st TO 8:00 P.M. JANUARY 2ND. IF NEW YEAR'S DAY IS ON A FRIDAY, SATURDAY, SUNDAY, OR MONDAY THEN UNTIL 8:00 P.M. THE FOLLOWING TUESDAY.
- FOR EASTER, BETWEEN THE HOURS OF 6:00 A.M. THURSDAY AND 8:00 P.M. MONDAY.
- FOR MEMORIAL DAY, BETWEEN THE HOURS OF 6:00 A.M. FRIDAY TO 8:00 P.M. TUESDAY.
- FOR INDEPENDENCE DAY, BETWEEN THE HOURS OF 6:00 A.M. THE DAY BEFORE INDEPENDENCE DAY AND 8:00 P.M. THE DAY AFTER INDEPENDENCE DAY.

IF INDEPENDENCE DAY IS ON A FRIDAY, SATURDAY, SUNDAY OR MONDAY THEN BETWEEN THE HOURS OF 6:00 A.M. THE THURSDAY BEFORE INDEPENDENCE DAY AND 8:00 P.M. THE TUESDAY AFTER INDEPENDENCE DAY.

- FOR LABOR DAY, BETWEEN THE HOURS OF 6:00 A.M. FRIDAY AND 8:00 P.M. TUESDAY.
- FOR THANKSGIVING DAY, BETWEEN THE HOURS OF 6:00 A.M. TUESDAY TO 8:00 P.M. MONDAY, FOR I-85 ONLY.
- FOR CHRISTMAS, BETWEEN THE HOURS OF 6:00 A.M. THE FRIDAY BEFORE THE WEEK OF CHRISTMAS DAY AND 8:00 P.M. THE FOLLOWING TUESDAY AFTER THE WEEK OF CHRISTMAS, FOR I-85 ONLY.
- FOR THANKSGIVING THROUGH THE CHRISTMAS HOLIDAY PERIOD BEGINNING ON THE TUESDAY OF THE WEEK OF THANKSGIVING AND ENDING ON THE FOLLOWING TUESDAY AFTER THE WEEK OF CHRISTMAS, FOR ALL RAMPS AND -L- ONLY:
6:00AM-9:00AM, 4:00PM-6:00PM, MONDAY THRU THURSDAY
6:00AM-8:00PM, FRIDAY THRU SUNDAY
- FOR FOOTBALL AND BASKETBALL GAMES AT UNC IN CHAPEL HILL BETWEEN 3 HOURS BEFORE THE START AND 2 HOURS AFTER THE END OF THE FOOTBALL AND BASKETBALL GAMES AT UNC IN CHAPEL HILL.

C) DO NOT CLOSE ROADS AS FOLLOWS:

ROAD NAME	DAY AND TIME RESTRICTIONS
-Y1- (I-40 / I-85)	6:00AM-1:00AM MONDAY THRU SUNDAY

D) DO NOT STOP TRAFFIC AS FOLLOWS:

ROAD NAME	DAY & TIME RESTRICTIONS	DURATION & OPERATION
-L- (MEBANE OAKS RD)	6:00AM-1:00AM	30 MIN CLOSURE
-Y1- (I-40 / I-85)	MONDAY THRU SUNDAY	FOR OVERHEAD
AND ALL RAMPS		SIGN INSTALLATION

E) DO NOT CONDUCT MULTI-VEHICLE HAULING AS FOLLOWS EGRESS FROM RAMPS WILL BE ALLOWED:

ROAD NAME	DAY AND TIME RESTRICTIONS
-Y1- I-40 / I-85	6:00AM-9:00AM, 4:00PM-6:00PM
AND ALL RAMPS	MONDAY THRU FRIDAY

F) DO NOT CONDUCT ANY HAULING OPERATIONS AGAINST THE FLOW OF TRAFFIC OF AN OPEN TRAVELWAY UNLESS THE HAULING OPERATION IS PROTECTED BY BARRIER OR GUARDRAIL OR AS DIRECTED BY THE ENGINEER.

LANE AND SHOULDER CLOSURE REQUIREMENTS

- REMOVE LANE CLOSURE FROM THE LANE WHEN WORK IS NOT BEING PERFORMED BEHIND THE LANE CLOSURE OF WHEN A LANE CLOSURE IS NO LONGER NEEDED OR AS DIRECTED BY THE ENGINEER
- WHEN PERSONNEL AND/OR EQUIPMENT ARE WORKING WITHIN 15 FT OF AN OPEN TRAVEL LANE, CLOSE THE NEAREST OPEN SHOULDER USING ROADWAY STANDARD DRAWING NO. 1101.04 UNLESS THE WORK AREA IS PROTECTED BY BARRIER OR GUARDRAIL OR A LANE CLOSURE IS INSTALLED.
- WHEN PERSONNEL AND/OR EQUIPMENT ARE WORKING ON THE SHOULDER ADJACENT TO AN UNDIVIDED FACILITY AND WITHIN 5 FT OF AN OPEN TRAVEL LANE, CLOSE THE NEAREST OPEN TRAVEL LANE USING ROADWAY STANDARD DRAWING NO. 1101.02 UNLESS THE WORK AREA IS PROTECTED BY BARRIER OR GUARDRAIL.

WHEN PERSONNEL AND/OR EQUIPMENT ARE WORKING ON THE SHOULDER ADJACENT TO A DIVIDED FACILITY AND WITHIN 10 FT OF AN OPEN TRAVEL LANE, CLOSE THE NEAREST OPEN TRAVEL LANE USING ROADWAY STANDARD DRAWING NO. 1101.02 UNLESS THE WORK AREA IS PROTECTED BY BARRIER OR GUARDRAIL.

J) WHEN PERSONNEL AND/OR EQUIPMENT ARE WORKING WITHIN A LANE OF TRAVEL OF AN UNDIVIDED OR DIVIDED FACILITY, CLOSE THE LANE ACCORDING TO THE TRAFFIC MANAGEMENT PLANS, ROADWAY STANDARD DRAWINGS, OR AS DIRECTED BY THE ENGINEER. CONDUCT THE WORK SO THAT ALL PERSONNEL AND/OR EQUIPMENT REMAIN WITHIN THE CLOSED TRAVEL LANE.

K) DO NOT WORK SIMULTANEOUSLY WITHIN 15 FT ON BOTH SIDES OF AN OPEN TRAVELWAY, RAMP, OR LOOP WITHIN THE SAME LOCATION UNLESS PROTECTED WITH GUARDRAIL OR BARRIER.

L) PROVIDE TRAFFIC CONTROL FOR APPROPRIATE LANE CLOSURES FOR SURVEYING DONE BY THE DEPARTMENT.

PAVEMENT EDGE DROP OFF REQUIREMENTS

M) BACKFILL AT A 6:1 SLOPE UP TO THE EDGE AND ELEVATION OF EXISTING PAVEMENT IN AREAS ADJACENT TO AN OPENED TRAVEL LANE THAT HAS AN EDGE OF PAVEMENT DROP-OFF AS FOLLOWS:

BACKFILL DROP-OFFS THAT EXCEED 2 INCHES ON ROADWAYS WITH POSTED SPEED LIMITS OF 45 MPH OR GREATER.

BACKFILL DROP-OFFS THAT EXCEED 3 INCHES ON ROADWAYS WITH POSTED SPEED LIMITS LESS THAN 45 MPH.

BACKFILL WITH SUITABLE COMPACTED MATERIAL, AS APPROVED BY THE ENGINEER, AT NO EXPENSE TO THE DEPARTMENT.

N) DO NOT EXCEED A DIFFERENCE OF 2 INCHES IN ELEVATION BETWEEN OPEN LANES OF TRAFFIC FOR NOMINAL LIFTS OF 1.5 INCHES. INSTALL ADVANCE WARNING "UNEVEN LANES" SIGNS (W8-11) 300 ft IN ADVANCE AND A MINIMUM OF EVERY HALF MILE THROUGHOUT THE UNEVEN AREA.

TRAFFIC PATTERN ALTERATIONS



O) NOTIFY THE ENGINEER THIRTY (30) CALENDAR DAYS PRIOR TO ANY TRAFFIC PATTERN ALTERATION.

SIGNING

P) INSTALL ADVANCE WORK ZONE WARNING SIGNS WHEN WORK IS WITHIN 40 FT FROM THE EDGE OF TRAVEL LANE AND NO MORE THAN THREE (3) DAYS PRIOR TO THE BEGINNING OF CONSTRUCTION.

Q) PROVIDE SIGNING AND DEVICES REQUIRED TO CLOSE THE ROAD ACCORDING TO THE ROADWAY STANDARD DRAWINGS AND TRAFFIC CONTROL PLANS.

PROVIDE SIGNING REQUIRED FOR THE OFF-SITE DETOUR ROUTE AS SHOWN IN THE TRAFFIC CONTROL PLANS.

<p style="font-size: small;">PLAN PREPARED IN THE OFFICE OF:</p> <p style="text-align: center; font-weight: bold; font-size: large;">PROGRESSIVE DESIGN GROUP, INC.</p> <p style="text-align: center; font-size: x-small;">ENGINEERS • CONSULTANTS</p>	<p>APPROVED: <i>Tim Arcy</i></p> <p>DATE: 2/26/2020</p> <p style="text-align: center;">SEAL</p>			TRANSPORTATION OPERATIONS PLAN
DOCUMENT NOT CONSIDERED FINAL UNLESS ALL SIGNATURES COMPLETED				

PROJECT NOTES

GENERAL NOTES

R) COVER OR REMOVE ALL SIGNS AND DEVICES REQUIRED TO CLOSE THE ROAD WHEN ROAD CLOSURE IS NOT IN OPERATION.

COVER OR REMOVE ALL SIGNS REQUIRED FOR THE OFF-SITE DETOUR WHEN THE DETOUR IS NOT IN OPERATION.

S) ENSURE ALL NECESSARY SIGNING IS IN PLACE PRIOR TO ALTERING ANY TRAFFIC PATTERN.

T) INSTALL BLACK ON ORANGE "DIP" SIGNS (W8-2) AND/OR "BUMP" SIGNS (W8-1) 300 ft IN ADVANCE OF THE UNEVEN AREA, OR AS DIRECTED BY THE ENGINEER.

TRAFFIC BARRIER

U) INSTALL TEMPORARY BARRIER ACCORDING TO THE TRANSPORTATION MANAGEMENT PLANS A MAXIMUM OF TWO (2) WEEKS PRIOR TO BEGINNING WORK IN ANY LOCATION. ONCE TEMPORARY BARRIER IS INSTALLED AT ANY LOCATION PROCEED IN A CONTINUOUS MANNER TO COMPLETE THE PROPOSED WORK IN THAT LOCATION UNLESS OTHERWISE STATED IN THE TRANSPORTATION MANAGEMENT PLANS OR AS DIRECTED BY THE ENGINEER.

DO NOT PLACE BARRIER DIRECTLY ON ANY SURFACE OTHER THAN ASPHALT OR CONCRETE.

ONCE TEMPORARY BARRIER IS INSTALLED AT ANY LOCATION AND NO WORK IS PERFORMED BEHIND THE TEMPORARY BARRIER FOR A PERIOD LONGER THAN TWO (2) MONTHS, REMOVE / RESET TEMPORARY BARRIER AT NO COST TO THE DEPARTMENT UNLESS OTHERWISE STATED IN THE TRANSPORTATION MANAGEMENT PLANS, TEMPORARY BARRIER IS PROTECTING A HAZARD, OR AS DIRECTED BY THE ENGINEER.

INSTALL TEMPORARY BARRIER WITH THE TRAFFIC FLOW BEGINNING WITH THE UPSTREAM SIDE OF TRAFFIC. REMOVE TEMPORARY BARRIER AGAINST THE TRAFFIC FLOW BEGINNING WITH THE DOWNSTREAM SIDE OF TRAFFIC.

INSTALL AND SPACE DRUMS NO GREATER THAN TWICE THE POSTED SPEED LIMIT (MPH) TO CLOSE OR KEEP THE SECTION OF THE ROADWAY CLOSED UNTIL THE TEMPORARY BARRIER CAN BE PLACED OR AFTER THE TEMPORARY BARRIER IS REMOVED.

V) PROTECT THE APPROACH END OF MOVABLE/PORTABLE CONCRETE BARRIER AT ALL TIMES DURING THE INSTALLATION AND REMOVAL OF THE BARRIER BY EITHER A TRUCK MOUNTED ATTENUATOR (MAXIMUM 72 HOURS) OR A TEMPORARY CRASH CUSHION.

PROTECT THE APPROACH END OF MOVABLE/PORTABLE CONCRETE BARRIER FROM ONCOMING TRAFFIC AT ALL TIMES BY A TEMPORARY CRASH CUSHION UNLESS THE APPROACH END OF MOVABLE/PORTABLE CONCRETE BARRIER IS OFFSET FROM ONCOMING TRAFFIC AS FOLLOWS OR AS SHOWN IN THE PLANS: (SEE ALSO 1101.05)

POSTED SPEED LIMIT	MINIMUM OFFSET
40 OR LESS	15 FT
45 - 50	20 FT
55	25 FT
60 MPH or HIGHER	30 FT

TRAFFIC CONTROL DEVICES

W) WHEN LANE CLOSURES ARE NOT IN EFFECT SPACE CHANNELIZING DEVICES IN WORK AREAS NO GREATER IN FEET THAN TWICE THE POSTED SPEED LIMIT (MPH) EXCEPT, 10 FT ON-CENTER IN RADII, AND 3 FT OFF THE EDGE OF AN OPEN TRAVELWAY. REFER TO STANDARD SPECIFICATIONS FOR ROADS AND STRUCTURES SECTIONS 1130 (DRUMS), 1135 (CONES) AND 1180 (SKINNY DRUMS) FOR ADDITIONAL REQUIREMENTS.

X) PLACE TYPE III BARRICADES, WITH "ROAD CLOSED" SIGN R11-2 ATTACHED, OF SUFFICIENT LENGTH TO CLOSE ENTIRE ROADWAY.

Y) PLACE ADDITIONAL SETS OF THREE CHANNELIZING DEVICES (DRUMS) PERPENDICULAR TO THE EDGE OF TRAVELWAY ON 500 FT CENTERS WHEN UNOPENED LANES ARE CLOSED TO TRAFFIC.

PAVEMENT MARKINGS AND MARKERS

ZZ) INSTALL TEMPORARY PAVEMENT MARKINGS AND TEMPORARY PAVEMENT MARKERS ON INTERIM LAYERS OF PAVEMENT AS FOLLOWS:

<u>ROAD NAME</u>	<u>MARKING</u>	<u>MARKER</u>
ALL ROADS	PAINT	TEMPORARY RAISED
BRIDGE DECKS	COLD APPLIED PLASTIC (TYPE IV - REMOVABLE TAPE)	TEMPORARY RAISED

AA) PLACE ONE APPLICATION OF PAINT FOR TEMPORARY TRAFFIC PATTERNS. PLACE A SECOND APPLICATION OF PAINT SIX (6) MONTHS AFTER THE INITIAL APPLICATION AND EVERY SIX MONTHS AS DIRECTED BY THE ENGINEER.

BB) TIE PROPOSED PAVEMENT MARKING LINES TO EXISTING PAVEMENT MARKING LINES.

CC) REMOVE/REPLACE ANY CONFLICTING/DAMAGED PAVEMENT MARKINGS AND MARKERS BY THE END OF EACH DAY'S OPERATION.

DD) TRACE THE EXISTING AND PROPOSED MONOLITHIC ISLAND LOCATIONS WITH PROPER COLOR PAVEMENT MARKINGS PRIOR TO REMOVAL AND INSTALLATION. PLACE DRUMS TO DELINEATE ANY EXISTING AND PROPOSED MONOLITHIC ISLANDS AFTER REMOVAL AND BEFORE INSTALLATION

MISCELLANEOUS

EE) LAW ENFORCEMENT MAY BE USED TO MAINTAIN TRAFFIC THROUGH THE WORK AREA AND/OR INTERSECTIONS AS DIRECTED BY THE ENGINEER. THE DEPARTMENT WILL PROVIDE POLICE CONTROL AT INTERSECTIONS WHEN REQUIRED. PROVIDE PORTABLE LIGHTING FOR LAW ENFORCEMENT WHEN THEY ARE CONTROLLING TRAFFIC AT INTERSECTIONS AT NIGHTTIME.

FF) ALL CURB RAMP LOCATIONS SHALL BE DERIVED FROM STATIONING SHOWN ON PAVEMENT MARKING PLANS OR AS DIRECTED BY THE ENGINEER IN COORDINATION WITH THE SIGNING AND DELINEATION UNIT.

GG) CONTRACTOR SHALL MAINTAIN SIDEWALK ACCESS AT ALL TIMES AS STATED IN THE PHASING. CONTRACTOR SHALL BE RESPONSIBLE TO PROVIDE TEMPORARY SIDEWALKS (CONCRETE, ASPHALT, OR OTHER SUITABLE MATERIAL AS APPROVED BY THE ENGINEER) AT ALL LOCATIONS WHERE THE OPEN PEDESTRIAN TRAVELWAY HAS BEEN REMOVED FOR CONSTRUCTION OPERATIONS (UTILITIES, DRAINAGE, ETC.).

USE THE PEDESTRIAN TRANSPORT SERVICE WHEN CLOSING SIDEWALK. SEE PEDESTRIAN TRANSPORT SERVICE SPECIAL PROVISION.

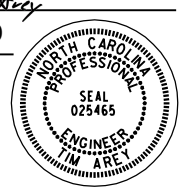
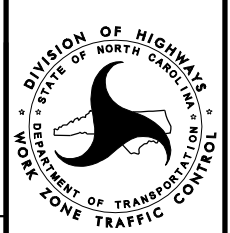
<p style="font-size: small;">PLAN PREPARED IN THE OFFICE OF:</p> <p style="text-align: center;">PROGRESSIVE DESIGN GROUP, INC.</p> <div style="display: flex; justify-content: center; gap: 5px;"> <div style="width: 15px; height: 15px; background-color: #ccc;"></div> <div style="width: 15px; height: 15px; background-color: #ccc;"></div> <div style="width: 15px; height: 15px; background-color: #ccc;"></div> <div style="width: 15px; height: 15px; background-color: #ccc;"></div> <div style="width: 15px; height: 15px; background-color: #ccc;"></div> <div style="width: 15px; height: 15px; background-color: #000;"></div> </div> <p style="font-size: x-small; text-align: center;">ENGINEERS • CONSULTANTS</p>	<p>APPROVED: <i>Tim Arey</i></p> <p>DATE: 2/26/2020</p> <p style="text-align: center;">SEAL</p> <div style="text-align: center;">  </div>	<div style="text-align: center;">  </div>	<p style="font-size: large; font-weight: bold;">TRANSPORTATION OPERATIONS PLAN</p>
<p style="font-size: small; font-weight: bold;">DOCUMENT NOT CONSIDERED FINAL UNLESS ALL SIGNATURES COMPLETED</p>			

LEADING EDGE LAYOUT FOR PORTABLE CONCRETE BARRIER

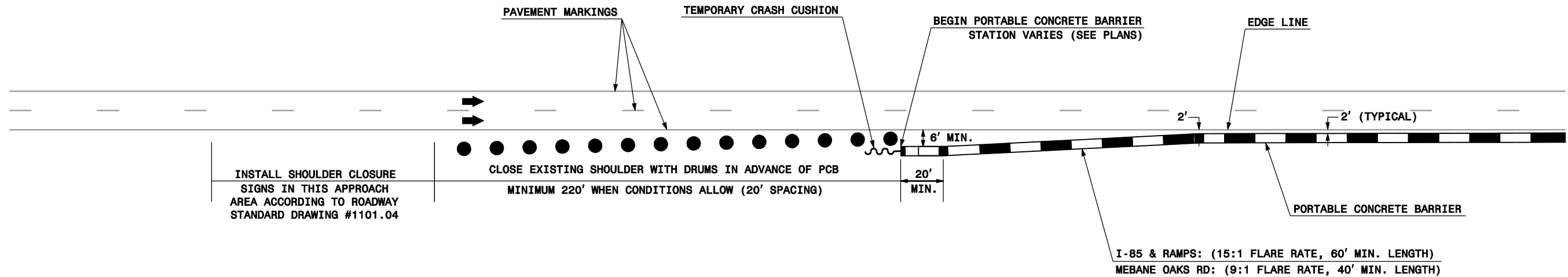

PLAN PREPARED IN THE OFFICE OF: PROGRESSIVE DESIGN GROUP, INC. ENGINEERS • CONSULTANTS	APPROVED: <i>Tim Arzy</i> DATE: 2/26/2020			TRANSPORTATION MANAGEMENT PLAN PCB TYPICAL
	SEAL			

USE THIS OFFSITE DETOUR ROUTE FOR I-85 TRAFFIC WHEN REMOVING SECTIONS OF THE EXISTING -L- BRIDGE DECKING OVER -Y1- (PHASE IA, STEP 3) AND WHEN INSTALLING PROPOSED -L- BRIDGE GIRDERS OVER -Y1- (PHASE IA, STEP 5 AND PHASE II, STEP 4).

REFER TO NCDOT RSD #1101.03, SHEET 7, FOR ADVANCE WARNING SIGNS AND DEVICES ON I-40/85.

REFER TO NCDOT RSD #1101.03, SHEET 7, FOR ADVANCE WARNING SIGNS AND DEVICES ON I-40/85.

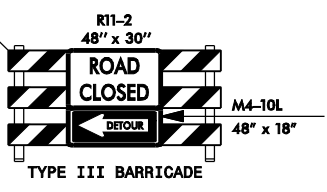
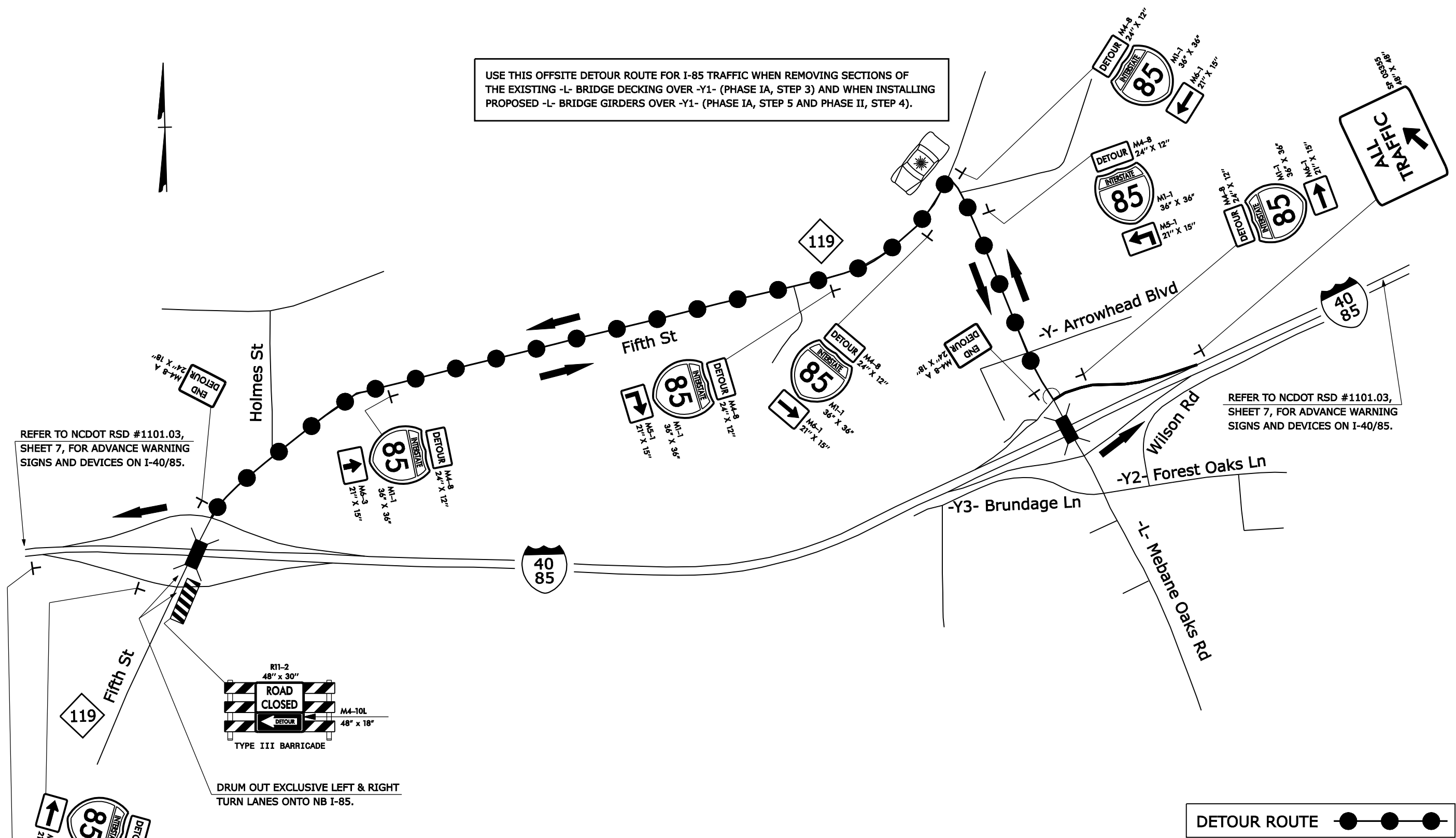

DRUM OUT EXCLUSIVE LEFT & RIGHT TURN LANES ONTO NB I-85.



PLAN PREPARED IN THE OFFICE OF: PROGRESSIVE DESIGN GROUP, INC. ENGINEERS • CONSULTANTS	APPROVED: <i>Tim Arey</i> DATE: 2/26/2020			TRANSPORTATION MANAGEMENT PLAN OFFSITE DETOUR ROUTE
	SEAL			

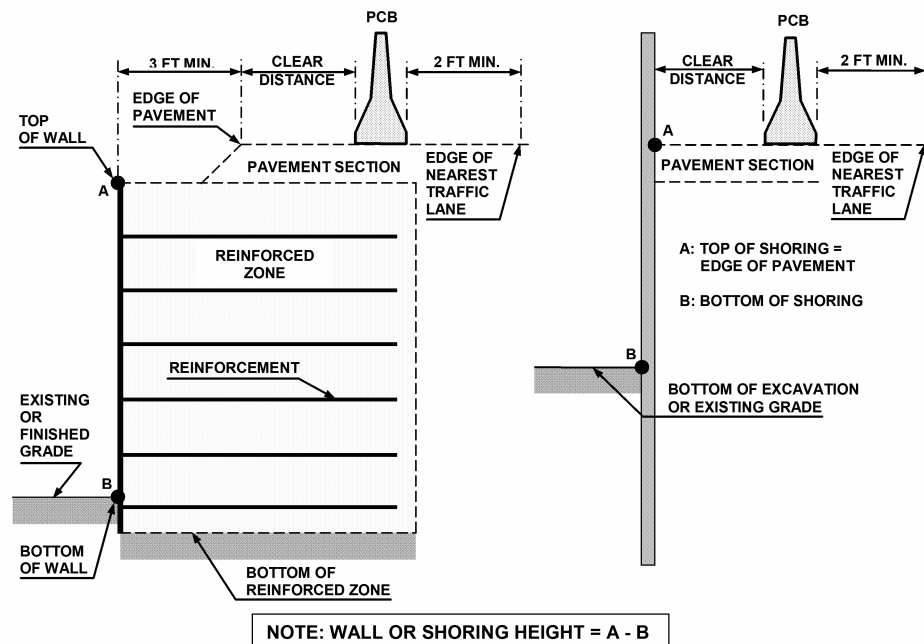

FIGURE A

NOTES

- 1- REFER TO THE TRAFFIC CONTROL PLANS FOR TEMPORARY SHORING LOCATIONS AND NOTES.
- 2- REFER TO THE "TEMPORARY SHORING" PROJECT SPECIAL PROVISION FOR INFORMATION ABOUT TEMPORARY SHORING AND PORTABLE CONCRETE BARRIER (PCB).
- 3- PCB IS REQUIRED IF TEMPORARY SHORING IS LOCATED WITHIN THE CLEAR ZONE IN ACCORDANCE WITH THE AASHTO ROADSIDE DESIGN GUIDE. DO NOT PLACE BARRIER DIRECTLY ON ANY SURFACE OTHER THAN ASPHALT OR CONCRETE. (CONTACT NCDOT PAVEMENT MANAGEMENT UNIT FOR APPLICABLE PAVEMENT DESIGN).
- 4- BASED ON THE CLEAR DISTANCE, OFFSET, DESIGN SPEED AND PAVEMENT TYPE, CHOOSE AN UNANCHORED OR ANCHORED PCB FROM THE TABLE SHOWN IN FIGURE B. CLEAR DISTANCE IS DEFINED AS SHOWN IN FIGURE A AND OFFSET IS DEFINED AS SHOWN IN FIGURE B.
- 5- AT THE CONTRACTOR'S OPTION OR IF THE MINIMUM REQUIRED CLEAR DISTANCE IS NOT AVAILABLE, SET PCB NEXT TO AND UP AGAINST THE TRAFFIC SIDE OF THE TEMPORARY SHORING EXCEPT FOR BARRIER ABOVE TEMPORARY WALLS. PCB WITH THE MINIMUM REQUIRED CLEAR DISTANCE IS REQUIRED ABOVE TEMPORARY WALLS.
- 6- USE NCDOT PORTABLE CONCRETE BARRIER (PCB) IN ACCORDANCE WITH ROADWAY STANDARD DRAWING NO. 1170.01 AND SECTION 1170 OF THE STANDARD SPECIFICATIONS.
- 7- PCB REQUIREMENTS FOR TEMPORARY WALLS APPLY TO TEMPORARY MECHANICALLY STABILIZED EARTH (MSE) WALLS AND TEMPORARY SOIL NAIL WALLS.
- 8- SET PCB WITH A MINIMUM HORIZONTAL DISTANCE OF 2 FT BETWEEN THE FRONT FACE OF THE BARRIER AND THE EDGE OF THE NEAREST TRAFFIC LANE AS SHOWN IN FIGURE A UNLESS OTHERWISE SHOWN IN THE PLANS AND OR AS APPROVED BY THE ENGINEER.
- 9- FOR PCB ABOVE AND BEHIND TEMPORARY WALLS, PROVIDE A MINIMUM DISTANCE OF 3 FT BETWEEN THE EDGE OF PAVEMENT AND THE WALL FACE AS SHOWN IN FIGURE A. IF THESE MINIMUM REQUIRED DISTANCES ARE NOT AVAILABLE, CONTACT THE ENGINEER.
- 10- TABLE SHOWN IN FIGURE B IS BASED ON NCDOT RESEARCH PROJECT NO. 2005-010 WITH VEHICLE TYPE USED FOR NCHRP 350 CRASH TESTS. BARRIER DEFLECTIONS AND RESULTING MINIMUM REQUIRED CLEAR DISTANCES MIGHT VARY SIGNIFICANTLY FOR LARGER HEAVIER VEHICLES, RUNS OF BARRIER LESS THAN 200 FT IN LENGTH AND WET OR DRY PAVEMENT.

Barrier Type	Pavement Type	Offset * ft	Design Speed, mph							
			<30	31-40	41-50	51-60	61-70	71-80		
Unanchored PCB	Asphalt	<8	24	26	29	32	36	40		
		8-14	26	28	31	35	38	42		
		14-20	27	29	34	36	39	43		
		20-26	28	31	35	38	40	44		
		26-32	29	32	36	39	42	45		
		32-38	30	34	38	41	43	46		
		38-44	31	34	41	43	45	48		
	Concrete	44-50	31	35	41	43	46	49		
		50-56	32	36	42	44	47	50		
		>56	32	36	42	45	47	51		
		<8	17	18	21	22	25	26		
		8-14	19	20	23	25	26	29		
		14-20	22	22	24	26	28	31		
		20-26	23	24	26	27	30	34		
Anchored PCB	Asphalt	26-32	24	25	27	28	32	35		
		32-38	24	26	27	30	33	36		
		38-44	25	26	28	30	34	37		
		44-50	26	26	28	32	35	37		
		50-56	26	26	28	32	35	38		
		>56	26	27	29	32	36	38		
		All Offsets	24 for All Design Speeds							
		Anchored PCB	Concrete (including bridge approach slabs)	All Offsets	12 for All Design Speeds					

* See Figure Below

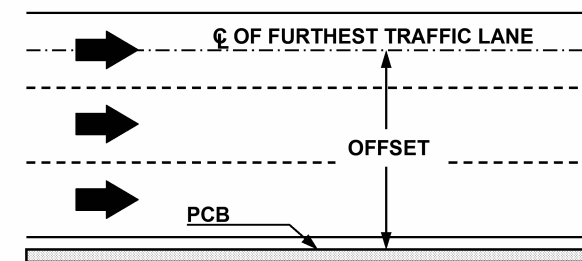

FIGURE B

PLAN PREPARED IN THE OFFICE OF: PROGRESSIVE DESIGN GROUP, INC. ENGINEERS • CONSULTANTS	APPROVED: <i>Tim Arvey</i> DATE: 2/26/2020	DIVISION OF HIGHWAYS STATE OF NORTH CAROLINA DEPARTMENT OF TRANSPORTATION WORK ZONE TRAFFIC CONTROL	PORTABLE CONCRETE BARRIER AT TEMPORARY SHORING LOCATIONS
	SEAL NORTH CAROLINA PROFESSIONAL ENGINEER SEAL 025465 ENGINEER TIM ARVEY		
DOCUMENT NOT CONSIDERED FINAL UNLESS ALL SIGNATURES COMPLETED			

TEMPORARY SHORING NO. 1

FOR TEMPORARY SHORING AND POSITIVE PROTECTION FOR TEMPORARY SHORING, SEE PLANS AND TEMPORARY SHORING PROVISION.

DESIGN TEMPORARY SHORING FROM STATION 25+65 +/- -L-, 27 FT. RT. TO STATION 26+00 +/- -L-, 27 FT. RT, FOR THE FOLLOWING ASSUMED SOIL PARAMETERS AND GROUNDWATER ELEVATION:

UNIT WEIGHT OF SOIL ABOVE WATER TABLE, . = 120 PCF
 UNIT WEIGHT OF SOIL BELOW WATER TABLE, .* = 60 PCF
 FRICTION ANGLE, f = 30
 COHESION, c = 0 PSF
 GROUNDWATER ELEVATION = 637 FT.

BEFORE BEGINNING TEMPORARY SHORING DESIGN OR CONSTRUCTION, SURVEY EXISTING GROUND ELEVATIONS IN THE VICINITY OF SHORING LOCATIONS TO DETERMINE ACTUAL SHORING HEIGHTS.

LIMITED SUBSURFACE INFORMATION IS AVAILABLE IN THE VICINITY OF TEMPORARY SHORING FROM STATION 25+65 +/- -L-, 27 FT. RT. TO STATION 26+00 +/- -L-, 27 FT. RT. THE INFORMATION PROVIDED FOR TEMPORARY SHORING DESIGN WAS ASSUMED AND MAY NOT BE APPLICABLE TO THE ACTUAL SITE CONDITIONS ENCOUNTERED DURING CONSTRUCTION.

DRIVEN PILING FOR TEMPORARY SHORING FROM STATION 25+65 +/- -L-, 27 FT. RT. TO STATION 26+00 +/- -L-, 27 FT. RT MAY NOT PENETRATE BELOW ELEVATION 640 FT. DUE TO OBSTRUCTIONS, VERY DENSE OR HARD SOIL, BOULDERS OR WEATHERED OR HARD ROCK.

AT THE CONTRACTOR*S OPTION, USE STANDARD TEMPORARY SHORING FOR TEMPORARY SHORING FROM STATION 25+65 +/- -L-, 27 FT. RT. TO STATION 26+00 +/- -L-, 27 FT. RT. SEE STANDARD DETAIL NO. 1801.01 FOR STANDARD TEMPORARY SHORING.

TEMPORARY SHORING NO. 2

FOR TEMPORARY SHORING AND POSITIVE PROTECTION FOR TEMPORARY SHORING, SEE PLANS AND TEMPORARY SHORING PROVISION.

DESIGN TEMPORARY SHORING FROM STATION 28+10 +/- -L-, 27 FT. RT. TO STATION 28+45 +/- -L-, 27 FT. RT, FOR THE FOLLOWING ASSUMED SOIL PARAMETERS AND GROUNDWATER ELEVATION:

UNIT WEIGHT OF SOIL ABOVE WATER TABLE, . = 120 PCF
 UNIT WEIGHT OF SOIL BELOW WATER TABLE, .* = 60 PCF
 FRICTION ANGLE, f = 30
 COHESION, c = 0 PSF
 GROUNDWATER ELEVATION = 637 FT.

BEFORE BEGINNING TEMPORARY SHORING DESIGN OR CONSTRUCTION, SURVEY EXISTING GROUND ELEVATIONS IN THE VICINITY OF SHORING LOCATIONS TO DETERMINE ACTUAL SHORING HEIGHTS.

LIMITED SUBSURFACE INFORMATION IS AVAILABLE IN THE VICINITY OF TEMPORARY SHORING FROM STATION 28+10 +/- -L-, 27 FT. RT. TO STATION 28+45 +/- -L-, 27 FT. RT. THE INFORMATION PROVIDED FOR TEMPORARY SHORING DESIGN WAS ASSUMED AND MAY NOT BE APPLICABLE TO THE ACTUAL SITE CONDITIONS ENCOUNTERED DURING CONSTRUCTION.

DRIVEN PILING FOR TEMPORARY SHORING FROM STATION 28+10 +/- -L-, 27 FT. RT. TO STATION 28+45 +/- -L-, 27 FT. RT MAY NOT PENETRATE BELOW ELEVATION 640 FT. DUE TO OBSTRUCTIONS, VERY DENSE OR HARD SOIL, BOULDERS OR WEATHERED OR HARD ROCK.

AT THE CONTRACTOR*S OPTION, USE STANDARD TEMPORARY SHORING FOR TEMPORARY SHORING FROM STATION 28+10 +/- -L-, 27 FT. RT. TO STATION 28+45 +/- -L-, 27 FT. RT. SEE STANDARD DETAIL NO. 1801.01 FOR STANDARD TEMPORARY SHORING.

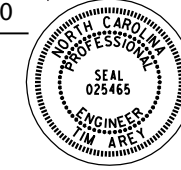
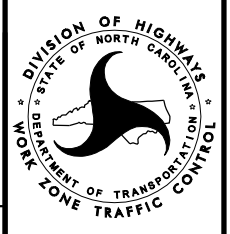
<p>PLAN PREPARED IN THE OFFICE OF:</p> <p>PROGRESSIVE DESIGN GROUP, INC.</p>  <p>ENGINEERS • CONSULTANTS</p>	<p>APPROVED: <i>Tim Arey</i></p> <p>DATE: 2/26/2020</p> <p>SEAL</p>  <p>DOCUMENT NOT CONSIDERED FINAL UNLESS ALL SIGNATURES COMPLETED</p>		<p>TEMPORARY SHORING DATA</p>
--	--	---	---------------------------------------

PROJECT PHASING

PHASE IA

STEP 1: INSTALL ADVANCE WORK ZONE WARNING SIGNS ON ALL ROADWAYS WITHIN THE PROJECT LIMITS ACCORDING TO ROADWAY STANDARD DRAWING NO. 1101.01.

STEP 2: USING ROADWAY STANDARD DRAWING NO. 1101.02 SHEET 1 OR 3 OF 15 BEGIN CONSTRUCTION ON THE FOLLOWING:
 -L-(LEFT SIDE): FROM THE -Y- INTERSECTION TO THE -RPAY1- INTERSECTION AND FROM THE -RPDY1- INTERSECTION TO THE -Y2- INTERSECTION AS SHOWN ON SHEETS TMP-4A AND TMP-4B.
 -L-(RIGHT SIDE): FROM THE -RPDY1- INTERSECTION TO THE -Y3- INTERSECTION AS SHOWN ON SHEET TMP-4B.
 -Y2-: IN THE LOCATIONS SHOWN ON SHEET TMP-4B.
 -Y3-: IN THE LOCATIONS SHOWN ON SHEET TMP-4B.

MODIFY THE EXISTING TRAFFIC SIGNALS AT THE -L-/-RPAY1- AND -L-/-RPDY1- INTERSECTIONS, REVISE THE PAVEMENT MARKINGS ON -L- BETWEEN -RPAY1- AND -RPDY1- TO THE PATTERN SHOWN ON SHEET TMP-4B AND INSTALL ANCHORED PORTABLE CONCRETE BARRIER AND TEMPORARY CRASH CUSHIONS ALONG THE RIGHT SIDE OF -L- IN THE LOCATIONS SHOWN ON SHEET TMP-4B. ANCHOR THE PORTABLE CONCRETE BARRIER TO THE EXISTING BRIDGE DECK.

STEP 3: BEHIND PORTABLE CONCRETE BARRIER, SAW CUT AND REMOVE THE PORTION OF THE EXISTING -L- BRIDGE OVER -Y1- SHOWN ON CROSS SECTION C-C, SHEET TMP-8. THIS OPERATION SHOULD TAKE PLACE ONLY WITHIN THE TIME RESTRICTIONS DICTATED ON GENERAL NOTE 'C', SHEET TMP-1B BY PLACING ALL -Y1- THRU TRAFFIC IN AN ALL TRAFFIC EXIT PATTERN. USE THE OFFSITE DETOUR ROUTE/SIGNING SHOWN ON SHEET TMP-2 FOR -Y1- TRAFFIC.

BEGIN CONSTRUCTION ON -L-(RIGHT SIDE) FROM THE -RPBY1- INTERSECTION TO THE -RPCY1- INTERSECTION AS SHOWN ON SHEET TMP-4B.

COMPLETE THE WORK REQUIRED OF PHASE IA, STEP 4A THRU STEP 4E IN 60 CONSECUTIVE CALENDAR DAYS. SEE INTERMEDIATE CONTRACT TIME AND LIQUIDATED DAMAGES.

STEP 4: USING ROADWAY STANDARD DRAWING NO. 1101.02, SHEET 4 OF 15, COMPLETE THE FOLLOWING:

- MILL THE RUMBLE STRIPS OFF OF THE EXISTING I-85 NORTHBOUND AND SOUTHBOUND OUTSIDE SHOULDER IN THE LOCATIONS WHERE THE NEW TEMPORARY PAVEMENT MARKINGS WILL BE TRAVERSING ONTO THE SHOULDER AS SHOWN ON SHEETS TMP-4B THRU TMP-4D. REPLACE THE MILLED SECTIONS OF ROADWAY WITH SURFACE COURSE AS SHOWN IN THE ROADWAY DESIGN PLAN TYPICALS.
- PLACE TEMPORARY PAVEMENT MARKINGS AND MARKERS ON NORTHBOUND AND SOUTHBOUND -Y1- AND PLACE NORTHBOUND AND SOUTHBOUND -Y1- TRAFFIC INTO THE PATTERNS SHOWN ON SHEETS TMP-4B THRU TMP-4D.
- INSTALL TEMPORARY CRASH CUSHIONS, PORTABLE CONCRETE BARRIER AND DRUMS ON NORTHBOUND AND SOUTHBOUND -Y1- IN THE LOCATIONS SHOWN ON SHEETS TMP-4B THRU TMP-4D.
- CONSTRUCT THE CENTER SUPPORTS FOR THE PROPOSED -L- BRIDGE OVER -Y1- ON BOTH SIDES OF THE EXISTING -L- BRIDGE OVER -Y1- AND REPLACE ANY PERMANENT MEDIAN BARRIER ALONG I-85 THAT WAS REMOVED FOR THE CENTER SUPPORT CONSTRUCTION.
- REMOVE THE PORTABLE CONCRETE BARRIER AND TEMPORARY CRASH CUSHIONS LOCATED IN THE MEDIAN OF NORTHBOUND AND SOUTHBOUND -Y1-. PLACE TEMPORARY PAVEMENT MARKINGS AND MARKERS ON NORTHBOUND AND SOUTHBOUND -Y1- BACK TO THE ORIGINAL PATTERN AND PLACE NORTHBOUND AND SOUTHBOUND -Y1- TRAFFIC BACK TO THE ORIGINAL PATTERN.

STEP 5: BEHIND PORTABLE CONCRETE BARRIER, BEGIN CONSTRUCTION ON THE PROPOSED SHOULDER PIERS, END BENTS AND DECK FOR THE PROPOSED RIGHT SIDE -L- BRIDGE WIDENING OVER -Y1- (INCLUDING THE PPC OVERLAY FOR THE NEW BRIDGE WIDENING DECK) AS SHOWN ON SHEET TMP-4B. GIRDER HANGING OPERATIONS SHOULD TAKE PLACE ONLY WITHIN THE TIME RESTRICTIONS DICTATED ON GENERAL NOTE 'C', SHEET TMP-1B BY PLACING ALL -Y1- THRU TRAFFIC IN AN ALL TRAFFIC EXIT PATTERN USE THE OFFSITE DETOUR ROUTE/SIGNING SHOWN ON SHEET TMP-2 FOR -Y1- TRAFFIC.

BEHIND PORTABLE CONCRETE BARRIER, BEGIN CONSTRUCTION ON THE PROPOSED SHOULDER PIERS FOR THE PROPOSED LEFT SIDE -L- BRIDGE WIDENING OVER -Y1- AS SHOWN ON SHEET TMP-4B.

PHASE IB

STEP 1: UTILIZING A FLAGGING OPERATION TO STOP TRAFFIC ON -RPBY1-, REVISE THE PAVEMENT MARKINGS ON -RPBY1- IN THE LOCATIONS SHOWN ON SHEET TMP-5B AND INSTALL PORTABLE CONCRETE BARRIER AND TEMPORARY CRASH CUSHION ALONG THE LEFT SIDE OF -RPBY1- IN THE LOCATIONS SHOWN ON SHEET TMP-5B.

STEP 2: CONSTRUCT THE PROPOSED -RPBY1- LEFT SIDE WIDENING IN THE LOCATIONS SHOWN ON SHEET TMP-5B.

USING ROADWAY STANDARD DRAWING NO. 1101.02 SHEET 1 OR 3 OF 15, BEGIN CONSTRUCTION ON THE FOLLOWING:
 -L-(RIGHT SIDE): FROM THE -Y- INTERSECTION TO THE -RPBY1- INTERSECTION AND FROM THE -Y3- INTERSECTION TO THE ENDING PROJECT LIMITS AS SHOWN ON SHEETS TMP-5B AND TMP-5C.
 -L-(LEFT SIDE): FROM THE -Y2- INTERSECTION TO THE ENDING PROJECT LIMITS AS SHOWN ON SHEETS TMP-5B AND TMP-5C.

PHASE IC

COMPLETE THE WORK REQUIRED OF PHASE IC, STEPS 1 THRU 3 IN 58 CONSECUTIVE HOURS BEGINNING AT 8:00PM ON A FRIDAY AND COMPLETING BY 6:00AM THE FOLLOWING MONDAY. SEE INTERMEDIATE CONTRACT TIME AND LIQUIDATED DAMAGES.

STEP 1: USING ROADWAY STANDARD DRAWING NO. 1101.02, SHEET 4 OF 15 CLOSE THE OUTSIDE LANE ON SOUTHBOUND I-85 AS SHOWN ON SHEET TMP-5D. INSTALL CHANGEABLE MESSAGE SIGNS AND DRUMS ON -RPBY1- IN THE PATTERN SHOWN ON SHEET TMP-5D.

STEP 2: UTILIZING A FLAGGING OPERATION TO STOP TRAFFIC ON -RPBY1-, EXTEND THE PORTABLE CONCRETE BARRIER ALONG -RPBY1- TO THE LOCATION SHOWN ON SHEET TMP-5D. CONSTRUCT THE REMAINING SECTION OF PROPOSED -RPBY1- BEHIND PORTABLE CONCRETE BARRIER IN THE LOCATIONS SHOWN ON SHEET TMP-5D.

STEP 3: USING ROADWAY STANDARD DRAWING NO. 1101.02, SHEET 4 OF 15, REMOVE THE PORTABLE CONCRETE BARRIER AND LANE CLOSURE ON SOUTHBOUND I-85 AND RETURN I-85 TRAFFIC BACK TO THE EXISTING TRAFFIC PATTERN.

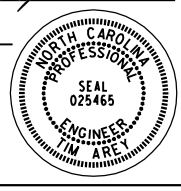
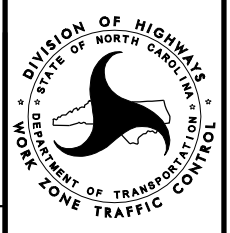
PLAN PREPARED IN THE OFFICE OF:  ENGINEERS • CONSULTANTS	APPROVED: <i>Tim Arey</i> DATE: 2/26/2020			TRANSPORTATION MANAGEMENT PLAN PROJECT PHASING
	SEAL			

PROJECT PHASING

PHASE II

- STEP 1: COMPLETE CONSTRUCTION ON THE PROPOSED RIGHT SIDE -L- BRIDGE WIDENING OVER -Y1- AND ALL ROADWAY WIDENING REQUIRED FOR THE TRAFFIC PATTERN SHOWN ON SHEETS TMP-6A AND TMP-6B UP TO BUT NOT INCLUDING THE FINAL LAYER OF SURFACE COURSE.
- REMOVE THE EXISTING ISLANDS ALONG -L- AND REPAIR ANY DAMAGED ROADWAY SURFACES AFTER REMOVAL.
- STEP 2: AWAY FROM EXISTING TRAFFIC PATTERNS, INSTALL AS MANY OF THE PROPOSED PAVEMENT MARKINGS AND MARKERS AS POSSIBLE FOR THE TRAFFIC PATTERN SHOWN ON SHEETS TMP-6A AND TMP-6B.
- STEP 3: USING ROADWAY STANDARD DRAWING NO. 1101.02, SHEETS 3 AND 7 OF 15, PLACE THE REMAINING PAVEMENT MARKINGS AND MARKERS ALONG -L- AND THE AFFECTED SIDE STREETS FOR THE TRAFFIC PATTERN SHOWN ON SHEETS TMP-6A AND TMP-6B AND PLACE ALL TRAFFIC IN THE PATTERN SHOWN ON SHEETS TMP-6A AND TMP-6B.
- INSTALL ANCHORED PORTABLE CONCRETE BARRIER AND TEMPORARY CRASH CUSHIONS ALONG THE LEFT SIDE OF -L- IN THE LOCATIONS SHOWN ON SHEET TMP-6B.
- STEP 4: BEHIND PORTABLE CONCRETE BARRIER, BEGIN CONSTRUCTION ON THE PROPOSED LEFT SIDE -L- BRIDGE WIDENING OVER -Y1- (INCLUDING THE PPC OVERLAY FOR THE NEW BRIDGE WIDENING DECK) AND PROPOSED -L- (LEFT SIDE) ROADWAY WIDENING BETWEEN -RPAY1- AND -RPDY1- UP TO BUT NOT INCLUDING THE FINAL LAYER OF SURFACE COURSE IN THE LOCATIONS SHOWN ON SHEET TMP-6B. GIRDER HANGING OPERATIONS SHOULD TAKE PLACE ONLY WITHIN THE TIME RESTRICTIONS DICTATED ON GENERAL NOTE 'C', SHEET TMP-1B. UTILIZE THE -Y1- OFFSITE DETOUR ROUTE SHOWN ON SHEET TMP-2 WHEN HANGING -L- GIRDERS OVER -Y1-.

PHASE IIA

- STEP 1: COMPLETE CONSTRUCTION ON THE PROPOSED RIGHT SIDE -L- ROADWAY WIDENING REQUIRED FOR THE TRAFFIC PATTERN SHOWN ON SHEETS TMP-6C AND TMP-6D UP TO BUT NOT INCLUDING THE FINAL LAYER OF SURFACE COURSE.
- STEP 2: AWAY FROM EXISTING TRAFFIC PATTERNS, INSTALL AS MANY OF THE PROPOSED PAVEMENT MARKINGS AND MARKERS AS POSSIBLE FOR THE TRAFFIC PATTERN SHOWN ON SHEETS TMP-6C AND TMP-6D.
- STEP 3: USING ROADWAY STANDARD DRAWING NO. 1101.02, SHEETS 3 AND 7 OF 15, PLACE THE REMAINING PAVEMENT MARKINGS AND MARKERS ALONG -L- AND THE AFFECTED SIDE STREETS FOR THE TRAFFIC PATTERN SHOWN ON SHEETS TMP-6C AND TMP-6D AND PLACE ALL TRAFFIC IN THE PATTERN SHOWN ON SHEETS TMP-6C AND TMP-6D.

PHASE III

- STEP 1: COMPLETE CONSTRUCTION ON THE PROPOSED LEFT SIDE -L- BRIDGE WIDENING OVER -Y1- AND ALL ROADWAY WIDENING REQUIRED FOR THE TRAFFIC PATTERN SHOWN ON SHEETS TMP-7A AND TMP-7B UP TO BUT NOT INCLUDING THE FINAL LAYER OF SURFACE COURSE. REMOVE THE PORTABLE CONCRETE BARRIER FROM -L-.
- STEP 2: AWAY FROM EXISTING TRAFFIC PATTERNS, INSTALL AS MANY OF THE PROPOSED PAVEMENT MARKINGS AND MARKERS AS POSSIBLE FOR THE -L- NORTHBOUND TRAFFIC PATTERN SHOWN ON SHEETS TMP-7A AND TMP-7B.
- STEP 3: USING ROADWAY STANDARD DRAWING NO. 1101.02, SHEETS 3 AND 7 OF 15, PLACE THE REMAINING PAVEMENT MARKINGS AND MARKERS ALONG -L- AND THE AFFECTED SIDE STREETS FOR THE -L- NORTHBOUND TRAFFIC PATTERN SHOWN ON SHEETS TMP-7A AND TMP-7B AND PLACE NORTHBOUND -L- TRAFFIC IN THE PATTERN SHOWN ON SHEETS TMP-7A AND TMP-7B.
- STEP 4: USING ROADWAY STANDARD DRAWING NO. 1101.02, SHEET 7 OF 15, CONSTRUCT THE PROPOSED MEDIAN ISLANDS ALONG -L- IN THE LOCATIONS SHOWN ON SHEETS TMP-7A AND TMP-7B.
- INSTALL PROPOSED OVERHEAD SIGNING IN THE LOCATIONS SHOWN IN THE SIGNING PLANS. OVERHEAD SIGN INSTALLATIONS SHOULD TAKE PLACE ONLY WITHIN THE TIME RESTRICTIONS DICTATED ON GENERAL NOTE 'D', SHEET TMP-1B.

COMPLETE THE WORK REQUIRED OF PHASE III, STEPS 5 THRU 7 IN 58 CONSECUTIVE HOURS BEGINNING AT 8:00PM ON A FRIDAY AND COMPLETING BY 6:00AM THE FOLLOWING MONDAY. SEE INTERMEDIATE CONTRACT TIME AND LIQUIDATED DAMAGES.

- STEP 5: CLOSE THE INSIDE EXCLUSIVE LEFT TURN LANE ON -RPCY1- USING DRUMS AS SHOWN ON SHEET TMP-7D.
- STEP 6: CLOSE THE INSIDE THRU LANE ON NORTHBOUND AND SOUTHBOUND -L- IN THE LOCATIONS SHOWN ON SHEETS TMP-7C AND TMP-7D. USE LAW ENFORCEMENT TO CONTROL TRAFFIC AT THE RAMP TERMINALS.
- STEP 7: COMPLETE THE PPC OVERLAY ON THE EXISTING -L- BRIDGE OVER -Y1-, INSTALL TEMPORARY TAPE PAVEMENT MARKINGS ON THE -L- BRIDGE DECK BACK TO THE PREVIOUS PATTERN SHOWN ON SHEET TMP-7A AND REOPEN ALL LANES ON -L- AND -RPCY1- TO TRAFFIC.
- STEP 8: COMPLETE CONSTRUCTION ON ALL ROADWAYS UP THRU THE FINAL LAYER OF SURFACE COURSE, INSTALL FINAL PAVEMENT MARKINGS AND MARKERS AND OPEN ALL ROADWAYS TO THE FINAL TRAFFIC PATTERN.

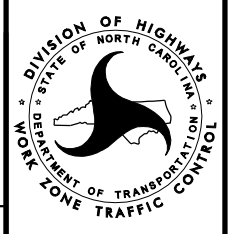
<p style="font-size: small;">PLAN PREPARED IN THE OFFICE OF:</p> <p style="text-align: center;">PROGRESSIVE DESIGN GROUP, INC.</p> <p style="text-align: center; font-size: x-small;">ENGINEERS • CONSULTANTS</p>	<p>APPROVED: <i>Tim Arey</i></p> <p>DATE: 2/26/2020</p> <p style="text-align: center;">SEAL</p> <div style="text-align: center;">  </div>	<div style="text-align: center;">  </div>	<p>TRANSPORTATION MANAGEMENT PLAN PROJECT PHASING</p>
<p>DOCUMENT NOT CONSIDERED FINAL UNLESS ALL SIGNATURES COMPLETED</p>			

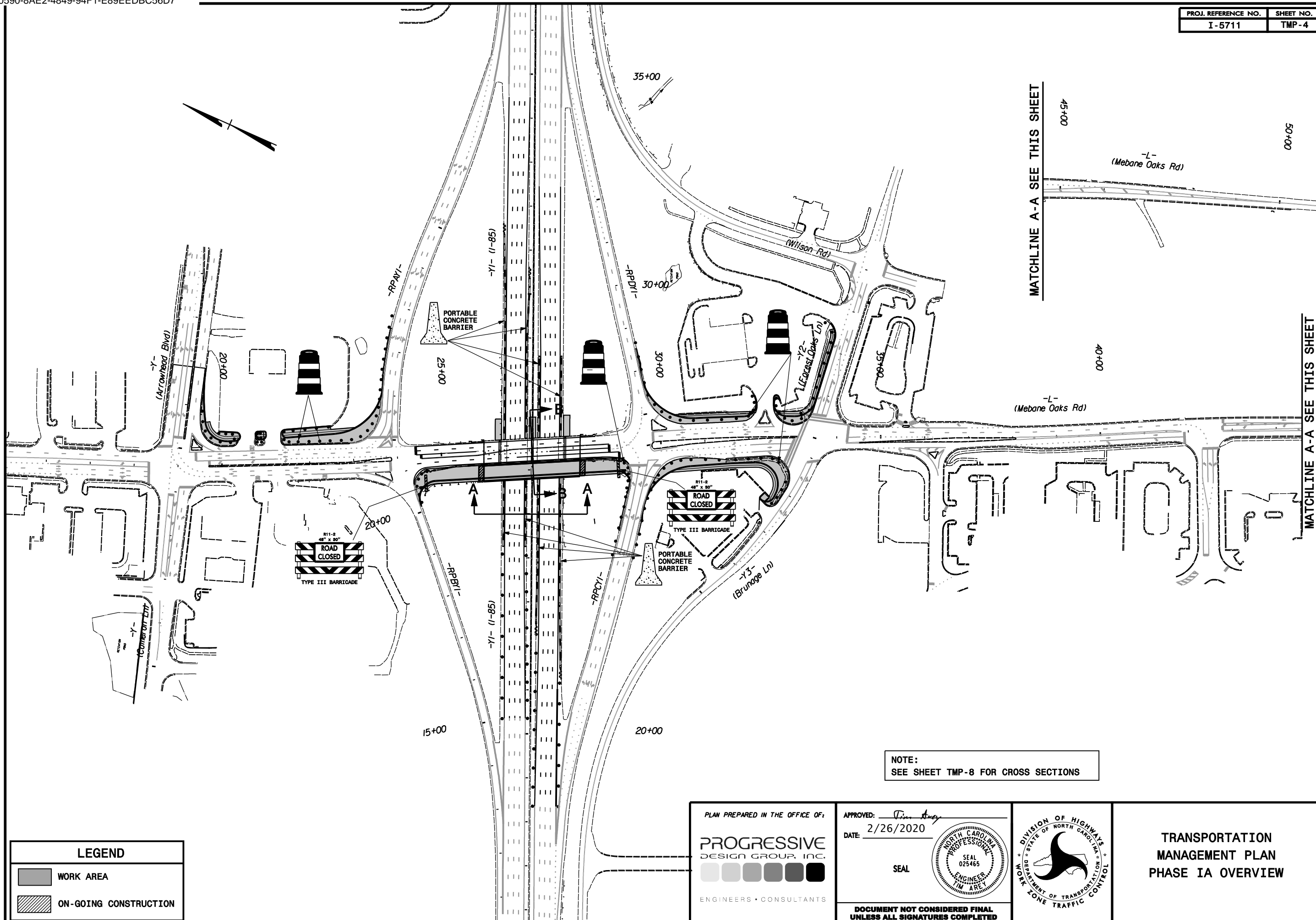

LEGEND	
	WORK AREA
	ON-GOING CONSTRUCTION

NOTE:
SEE SHEET TMP-8 FOR CROSS SECTIONS

PLAN PREPARED IN THE OFFICE OF: PROGRESSIVE DESIGN GROUP, INC. ENGINEERS • CONSULTANTS	APPROVED: <i>Tim Arey</i> DATE: 2/26/2020			TRANSPORTATION MANAGEMENT PLAN PHASE IA OVERVIEW
	SEAL			

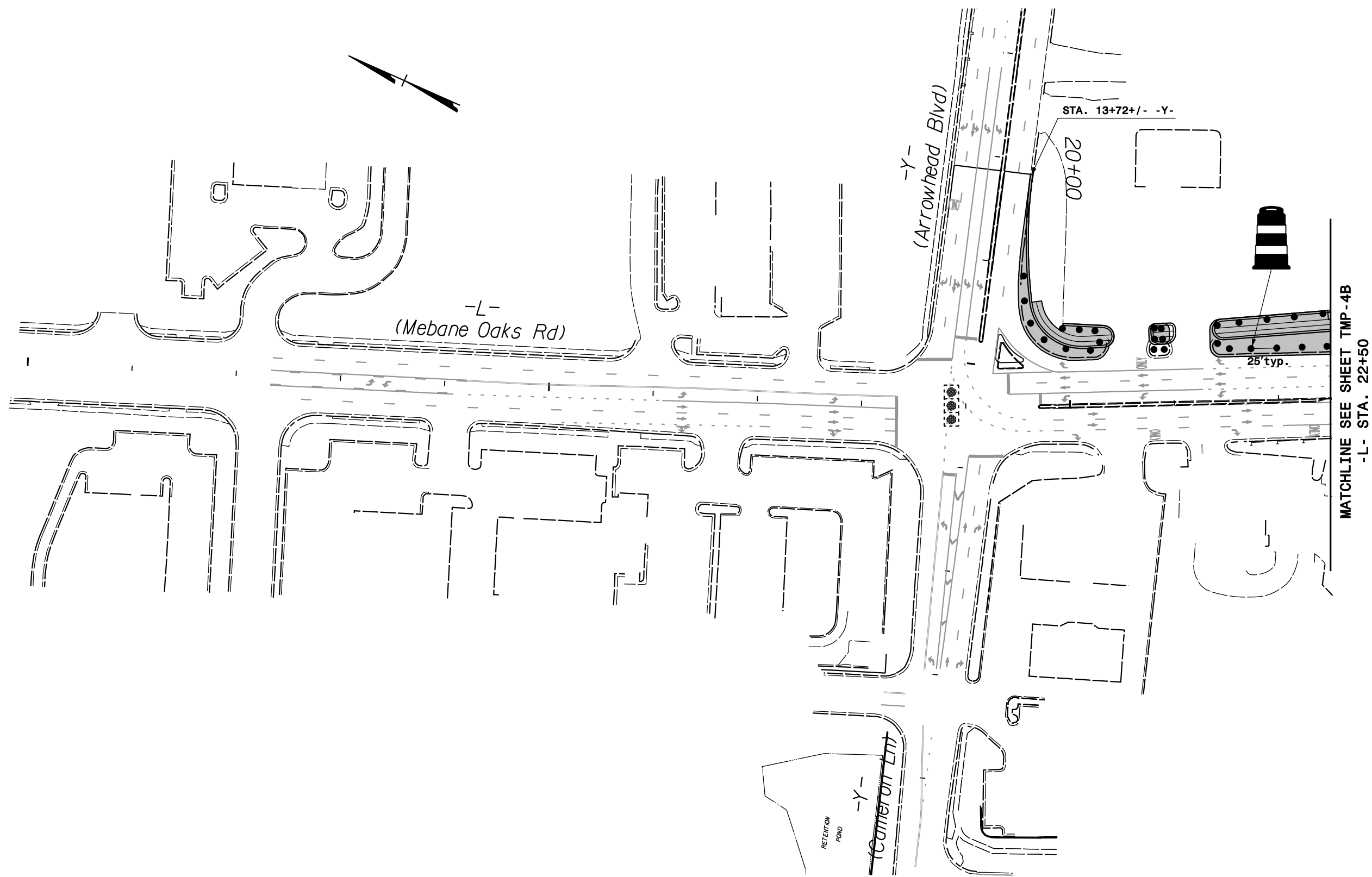

MATCHLINE SEE SHEET TMP-4B
-L- STA. 22+50

LEGEND	
	WORK AREA
	ON-GOING CONSTRUCTION

PLAN PREPARED IN THE OFFICE OF: PROGRESSIVE DESIGN GROUP, INC. ENGINEERS • CONSULTANTS	APPROVED: <i>Tim Arvey</i> DATE: 2/26/2020			TRANSPORTATION MANAGEMENT PLAN PHASE IA DETAILS
	SEAL			

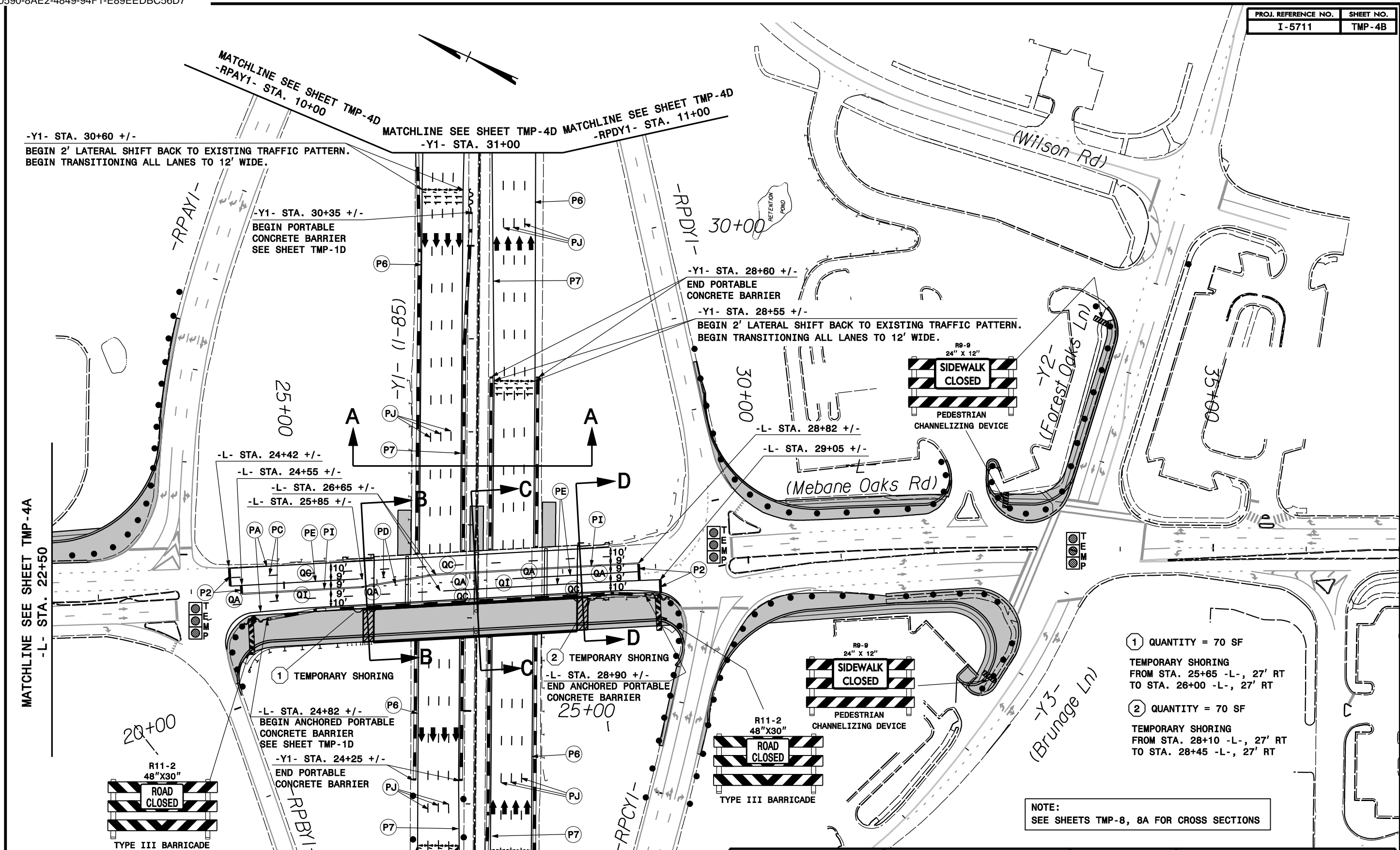

LEGEND	
	WORK AREA
	ON-GOING CONSTRUCTION

- ① QUANTITY = 70 SF
TEMPORARY SHORING
FROM STA. 25+65 -L-, 27' RT
TO STA. 26+00 -L-, 27' RT
- ② QUANTITY = 70 SF
TEMPORARY SHORING
FROM STA. 28+10 -L-, 27' RT
TO STA. 28+45 -L-, 27' RT

NOTE:
SEE SHEETS TMP-8, 8A FOR CROSS SECTIONS

PLAN PREPARED IN THE OFFICE OF: PROGRESSIVE DESIGN GROUP, INC. ENGINEERS • CONSULTANTS	APPROVED: <i>Tim Arey</i> DATE: 2/26/2020			TRANSPORTATION MANAGEMENT PLAN PHASE IA DETAILS
	SEAL			

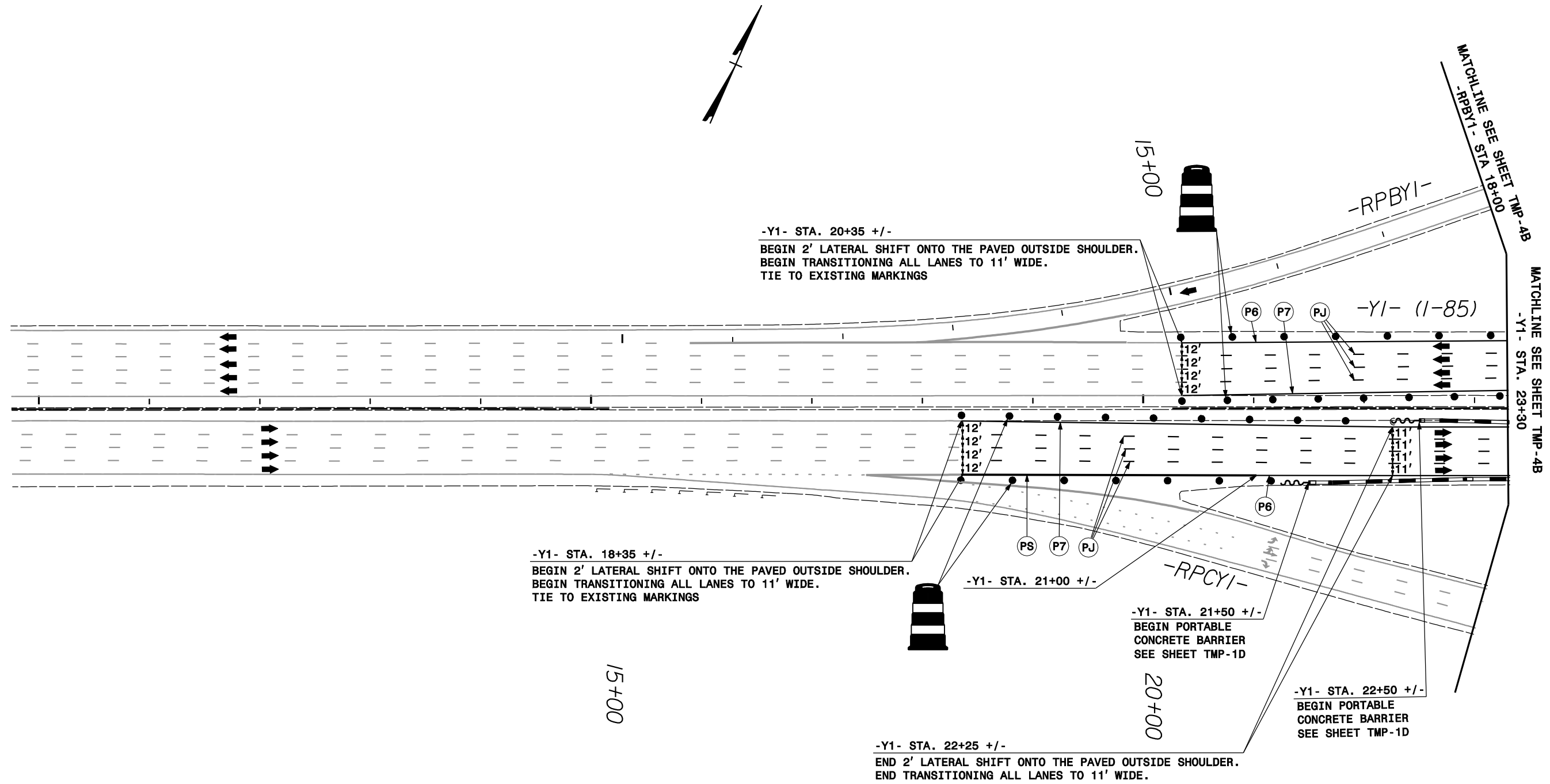

LEGEND	
	WORK AREA
	ON-GOING CONSTRUCTION

PLAN PREPARED IN THE OFFICE OF: PROGRESSIVE DESIGN GROUP, INC. ENGINEERS • CONSULTANTS	APPROVED: <i>Tim Arey</i> DATE: 2/26/2020			TRANSPORTATION MANAGEMENT PLAN PHASE IA DETAILS
	SEAL			

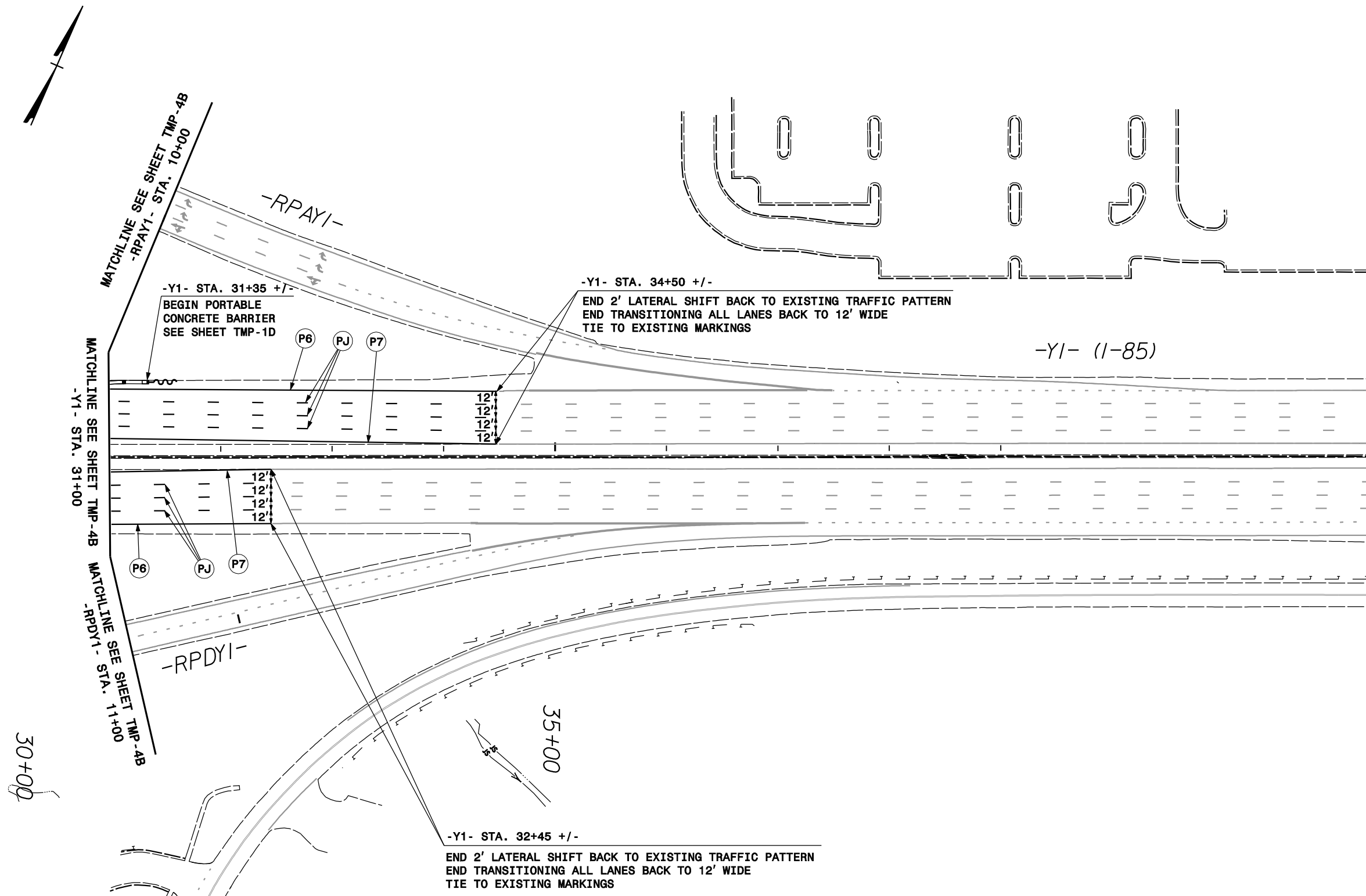

LEGEND	
	WORK AREA
	ON-GOING CONSTRUCTION

PLAN PREPARED IN THE OFFICE OF:

PROGRESSIVE
DESIGN GROUP, INC.

ENGINEERS • CONSULTANTS

APPROVED: *Tim Arey*

DATE: 2/26/2020

SEAL

SEAL
NORTH CAROLINA
PROFESSIONAL
ENGINEER
TIM AREY
025465

DOCUMENT NOT CONSIDERED FINAL
UNLESS ALL SIGNATURES COMPLETED

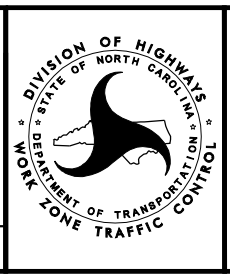

TRANSPORTATION
MANAGEMENT PLAN
PHASE IA DETAILS

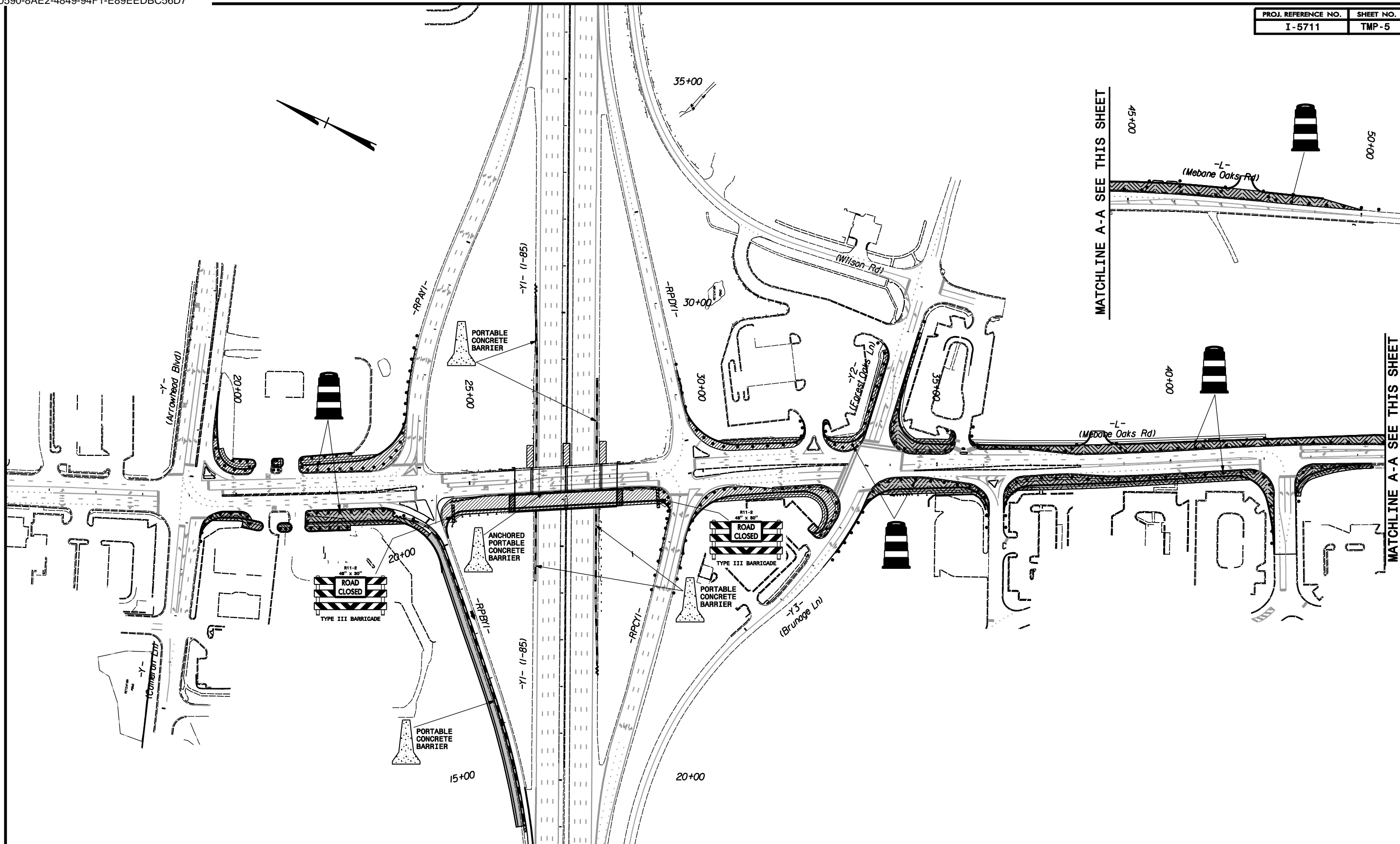

MATCHLINE A-A SEE THIS SHEET

MATCHLINE A-A SEE THIS SHEET

LEGEND	
	WORK AREA
	ON-GOING CONSTRUCTION
	WORK AREA WITH A DELAY OF ENTRY (SEE SPECIAL PROVISIONS)

PLAN PREPARED IN THE OFFICE OF:

PROGRESSIVE DESIGN GROUP, INC.

ENGINEERS • CONSULTANTS

APPROVED: *Tim Arey*

DATE: 2/26/2020

SEAL

DOCUMENT NOT CONSIDERED FINAL
UNLESS ALL SIGNATURES COMPLETED

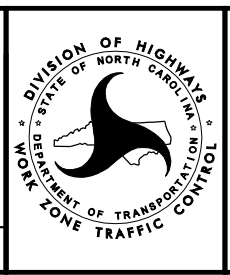

TRANSPORTATION MANAGEMENT PLAN

PHASE IB OVERVIEW

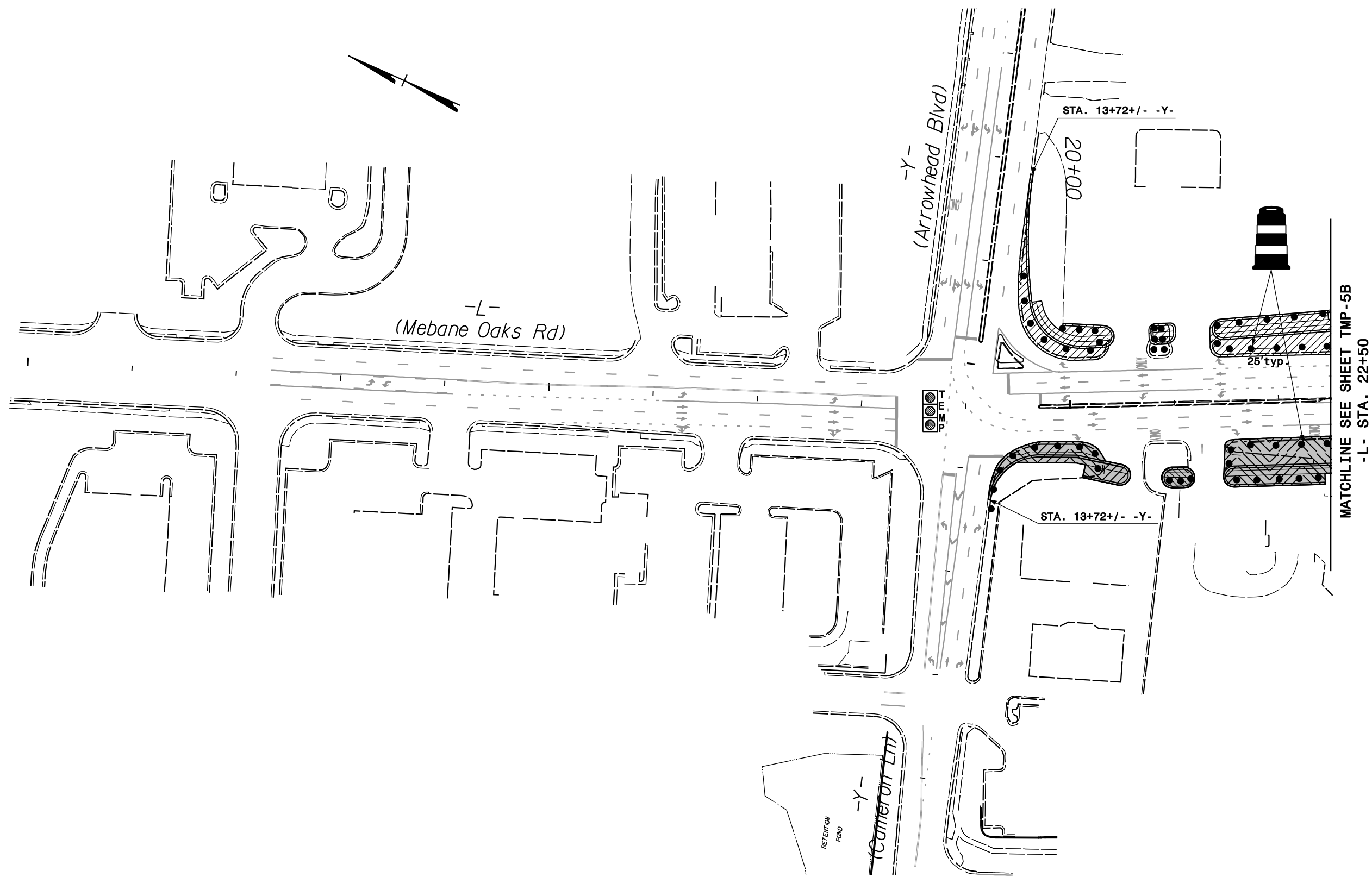

LEGEND	
	WORK AREA
	ON-GOING CONSTRUCTION
	WORK AREA WITH A DELAY OF ENTRY (SEE SPECIAL PROVISIONS)

PLAN PREPARED IN THE OFFICE OF:

PROGRESSIVE DESIGN GROUP, INC.

ENGINEERS • CONSULTANTS

APPROVED: *Tim Arey*

DATE: 2/26/2020

SEAL

SEAL

DOCUMENT NOT CONSIDERED FINAL
UNLESS ALL SIGNATURES COMPLETED

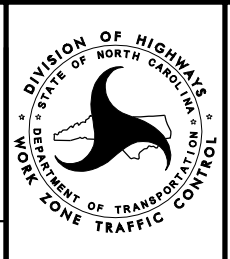

TRANSPORTATION
MANAGEMENT PLAN
PHASE IB DETAILS

MATCHLINE SEE SHEET TMP-5A
-L- STA. 22+50

MATCHLINE SEE SHEET TMP-5C
-L- STA. 22+50

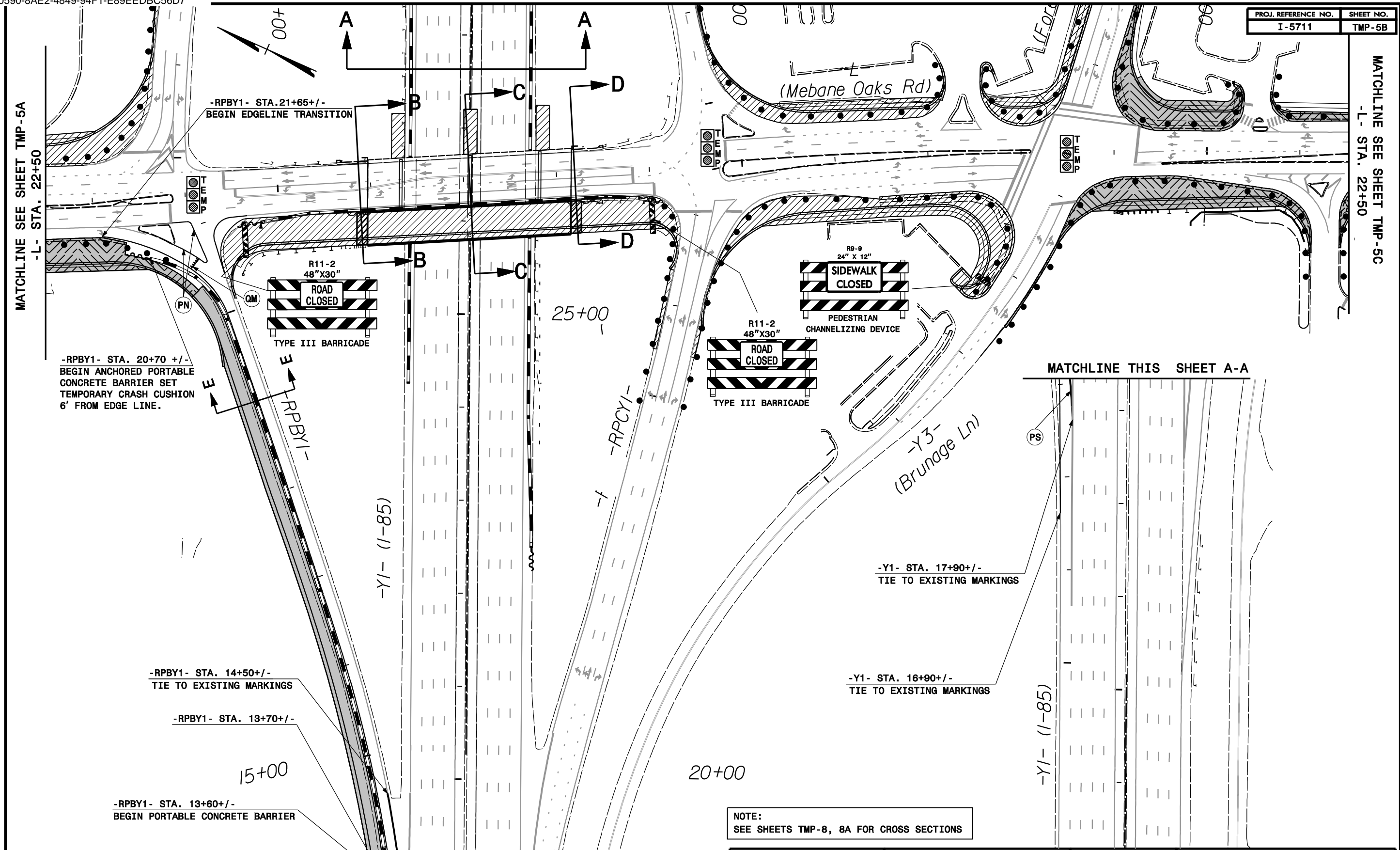

LEGEND	
	WORK AREA
	ON-GOING CONSTRUCTION
	WORK AREA WITH A DELAY OF ENTRY (SEE SPECIAL PROVISIONS)

NOTE:
SEE SHEETS TMP-8, 8A FOR CROSS SECTIONS

PLAN PREPARED IN THE OFFICE OF:

PROGRESSIVE DESIGN GROUP, INC.

ENGINEERS • CONSULTANTS

APPROVED: *Jim Arey*

DATE: 2/26/2020

SEAL

DOCUMENT NOT CONSIDERED FINAL UNLESS ALL SIGNATURES COMPLETED

TRANSPORTATION MANAGEMENT PLAN
PHASE IB DETAILS

MATCHLINE THIS SHEET A-A

MATCHLINE THIS SHEET A-A

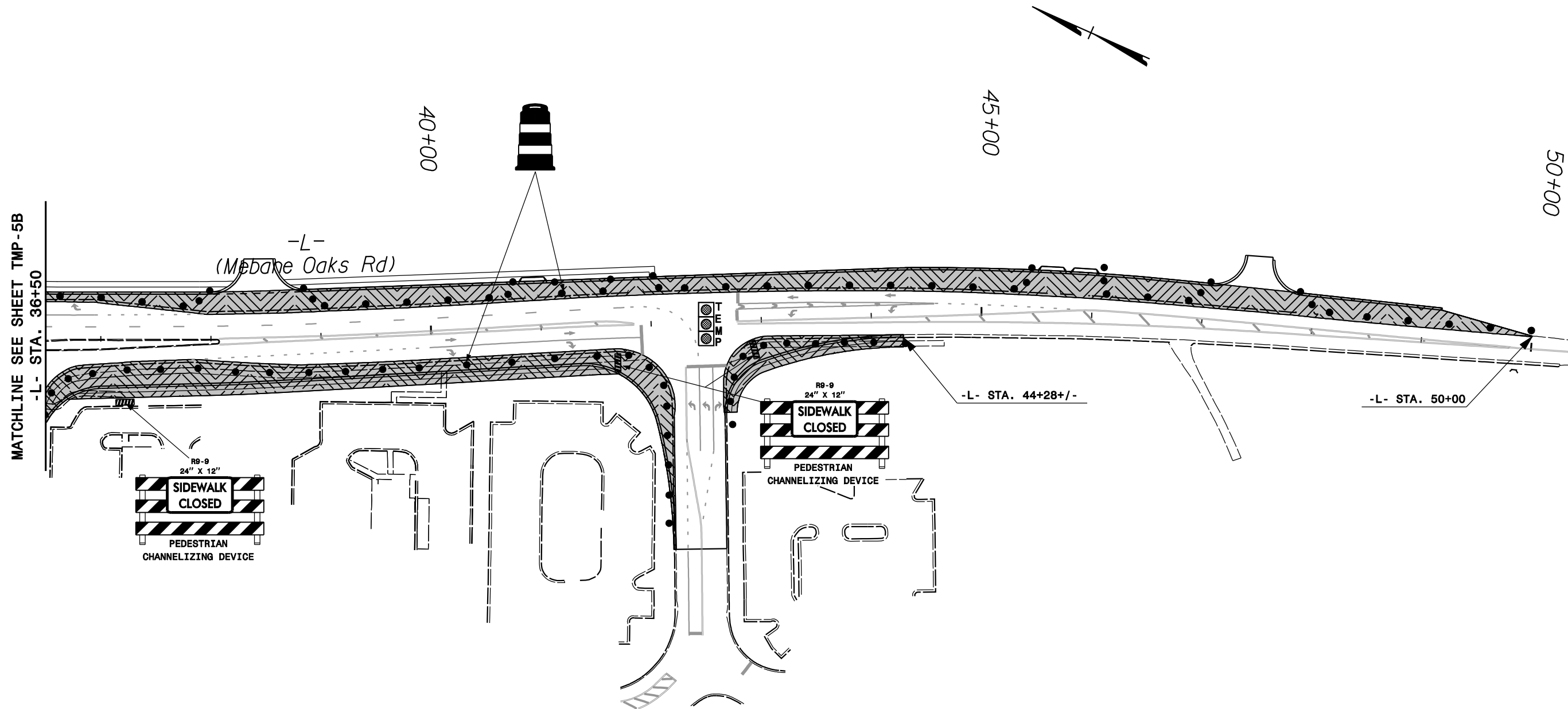

LEGEND	
	WORK AREA
	ON-GOING CONSTRUCTION
	WORK AREA WITH A DELAY OF ENTRY (SEE SPECIAL PROVISIONS)

PLAN PREPARED IN THE OFFICE OF:

PROGRESSIVE DESIGN GROUP, INC.

ENGINEERS • CONSULTANTS

APPROVED: *Tim Arey*

DATE: 2/26/2020

SEAL

PROFESSIONAL ENGINEER
TIM AREY
SEAL 025465
NORTH CAROLINA

DIVISION OF HIGHWAYS
STATE OF NORTH CAROLINA
DEPARTMENT OF TRANSPORTATION
WORK ZONE TRAFFIC CONTROL

**TRANSPORTATION MANAGEMENT PLAN
PHASE IB DETAILS**

DOCUMENT NOT CONSIDERED FINAL
UNLESS ALL SIGNATURES COMPLETED

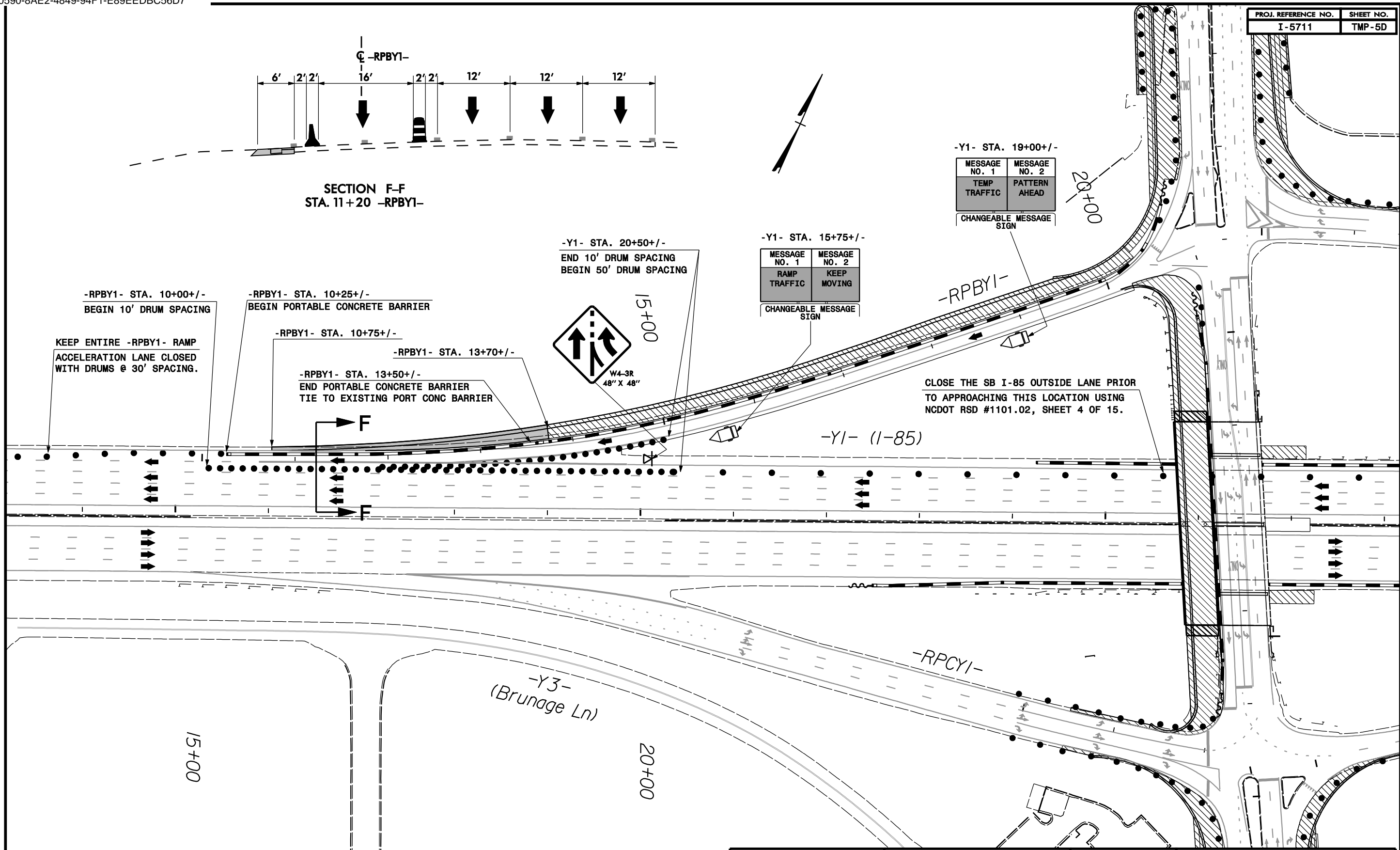

LEGEND	
	WORK AREA
	ON-GOING CONSTRUCTION

PLAN PREPARED IN THE OFFICE OF: PROGRESSIVE DESIGN GROUP, INC. ENGINEERS • CONSULTANTS	APPROVED: <i>Tim Arey</i> DATE: 2/26/2020			TRANSPORTATION MANAGEMENT PLAN PHASE IC DETAIL
	SEAL			

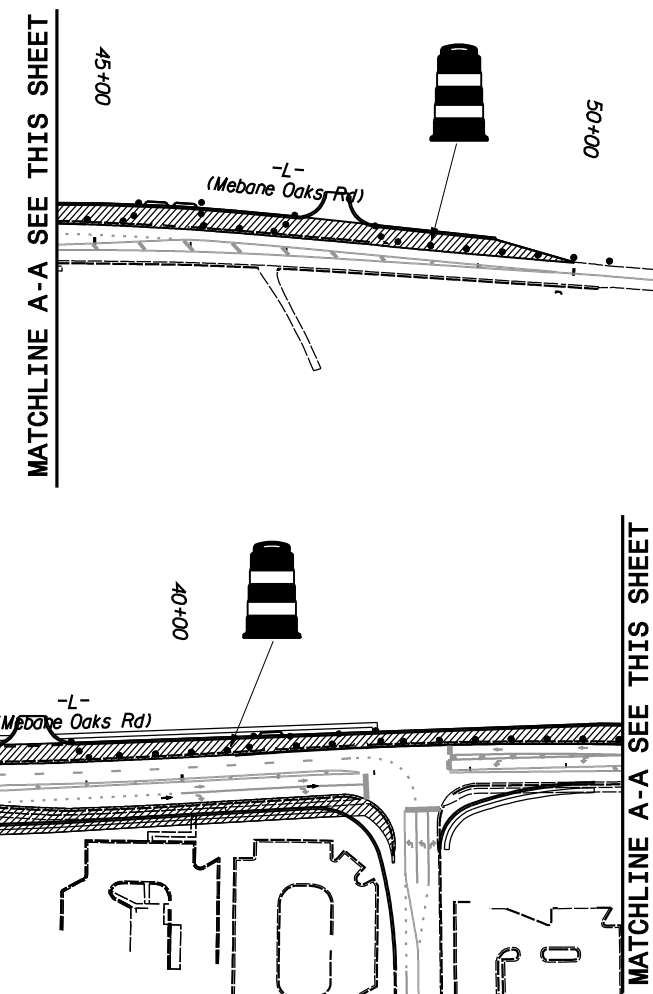
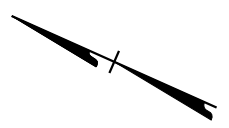
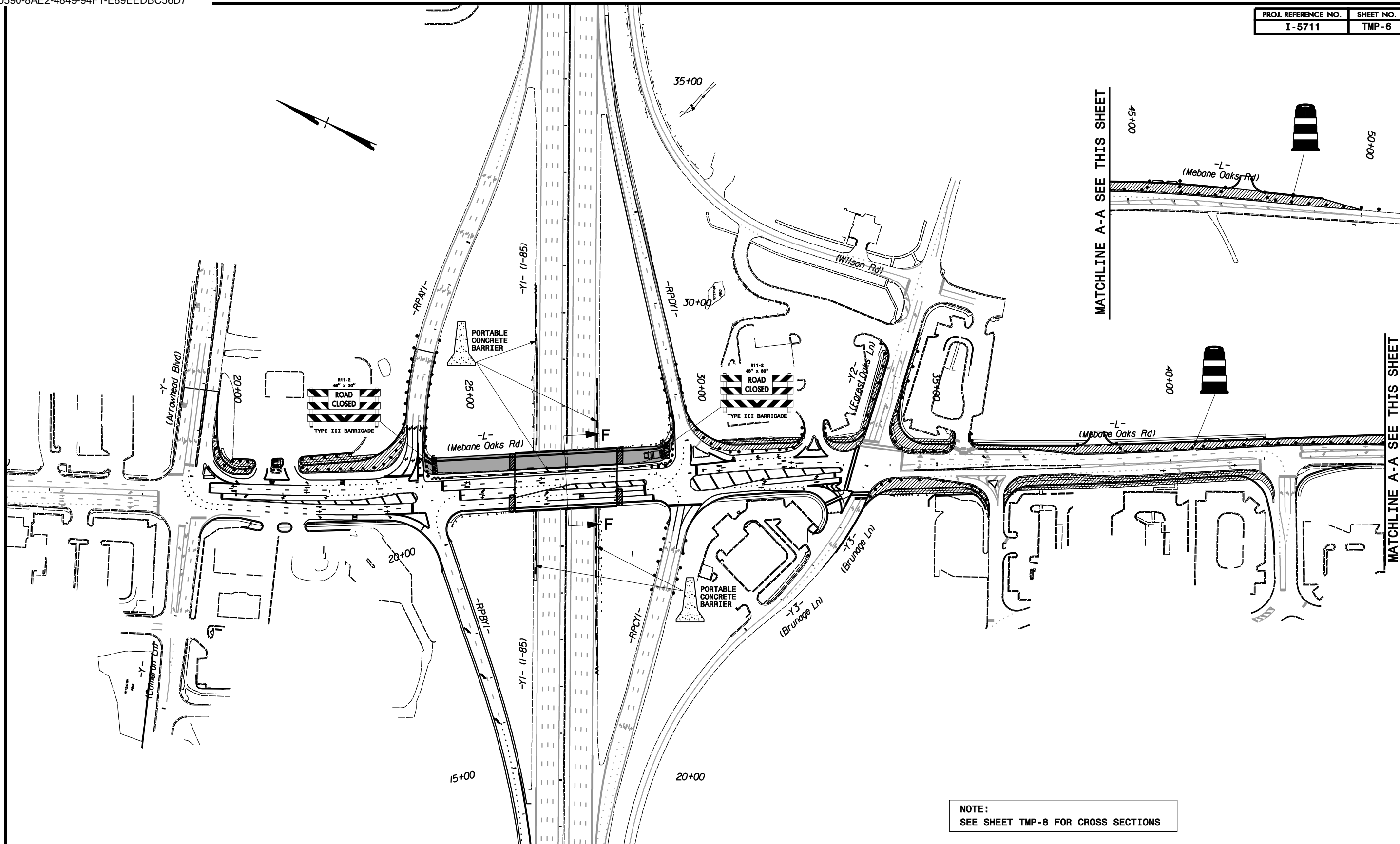

LEGEND	
	WORK AREA
	ON-GOING CONSTRUCTION

NOTE:
SEE SHEET TMP-8 FOR CROSS SECTIONS

PLAN PREPARED IN THE OFFICE OF: PROGRESSIVE DESIGN GROUP, INC. ENGINEERS • CONSULTANTS	APPROVED: <i>Tim Arey</i> DATE: 2/26/2020			TRANSPORTATION MANAGEMENT PLAN PHASE II OVERVIEW
	SEAL			

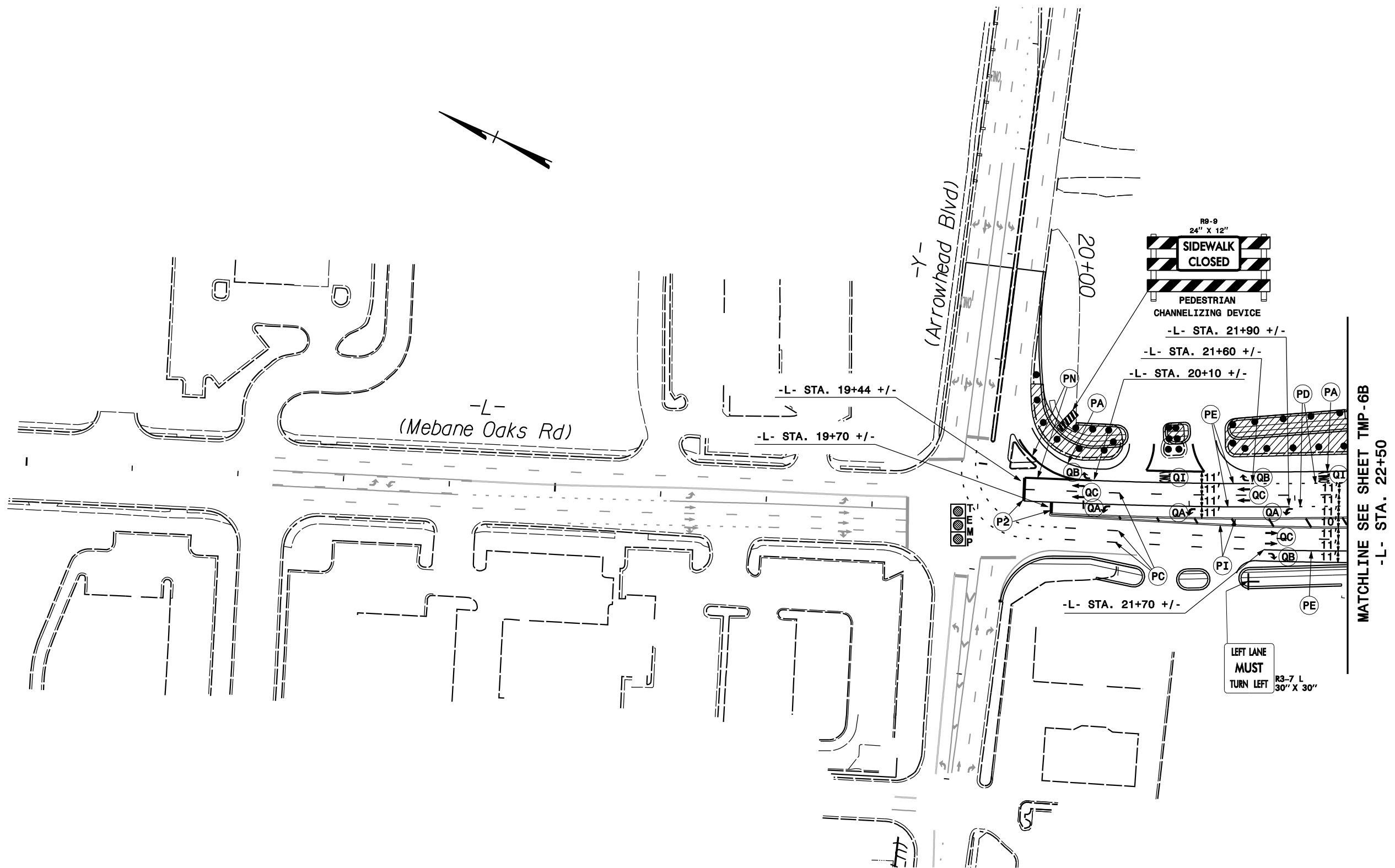

LEGEND	
	WORK AREA
	ON-GOING CONSTRUCTION

PLAN PREPARED IN THE OFFICE OF:
PROGRESSIVE DESIGN GROUP, INC.
 ENGINEERS • CONSULTANTS

APPROVED: *Tim Arey*
 DATE: 2/26/2020

SEAL

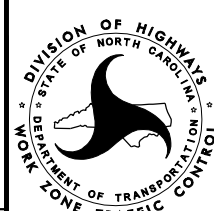
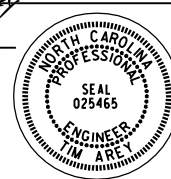

DOCUMENT NOT CONSIDERED FINAL
 UNLESS ALL SIGNATURES COMPLETED

TRANSPORTATION
 MANAGEMENT PLAN
 PHASE II DETAILS

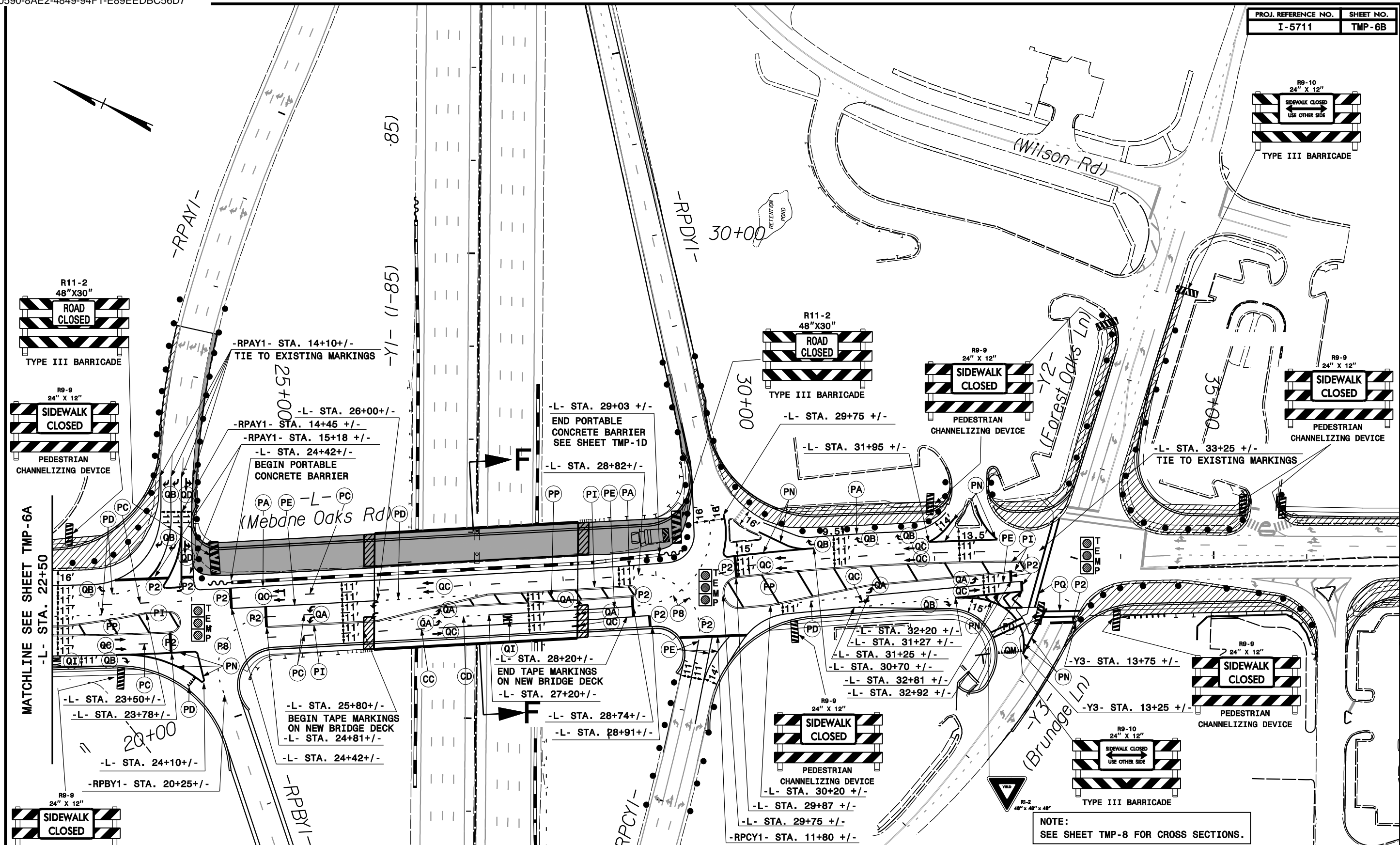

MATCHLINE SEE SHEET TMP-6A
-L- STA. 22+50

NOTE:
SEE SHEET TMP-8 FOR CROSS SECTIONS.

LEGEND	
	WORK AREA
	ON-GOING CONSTRUCTION

PLAN PREPARED IN THE OFFICE OF: PROGRESSIVE DESIGN GROUP, INC. ENGINEERS • CONSULTANTS	APPROVED: <i>Tim Arey</i> DATE: 2/26/2020			TRANSPORTATION MANAGEMENT PLAN PHASE II DETAILS
	SEAL			

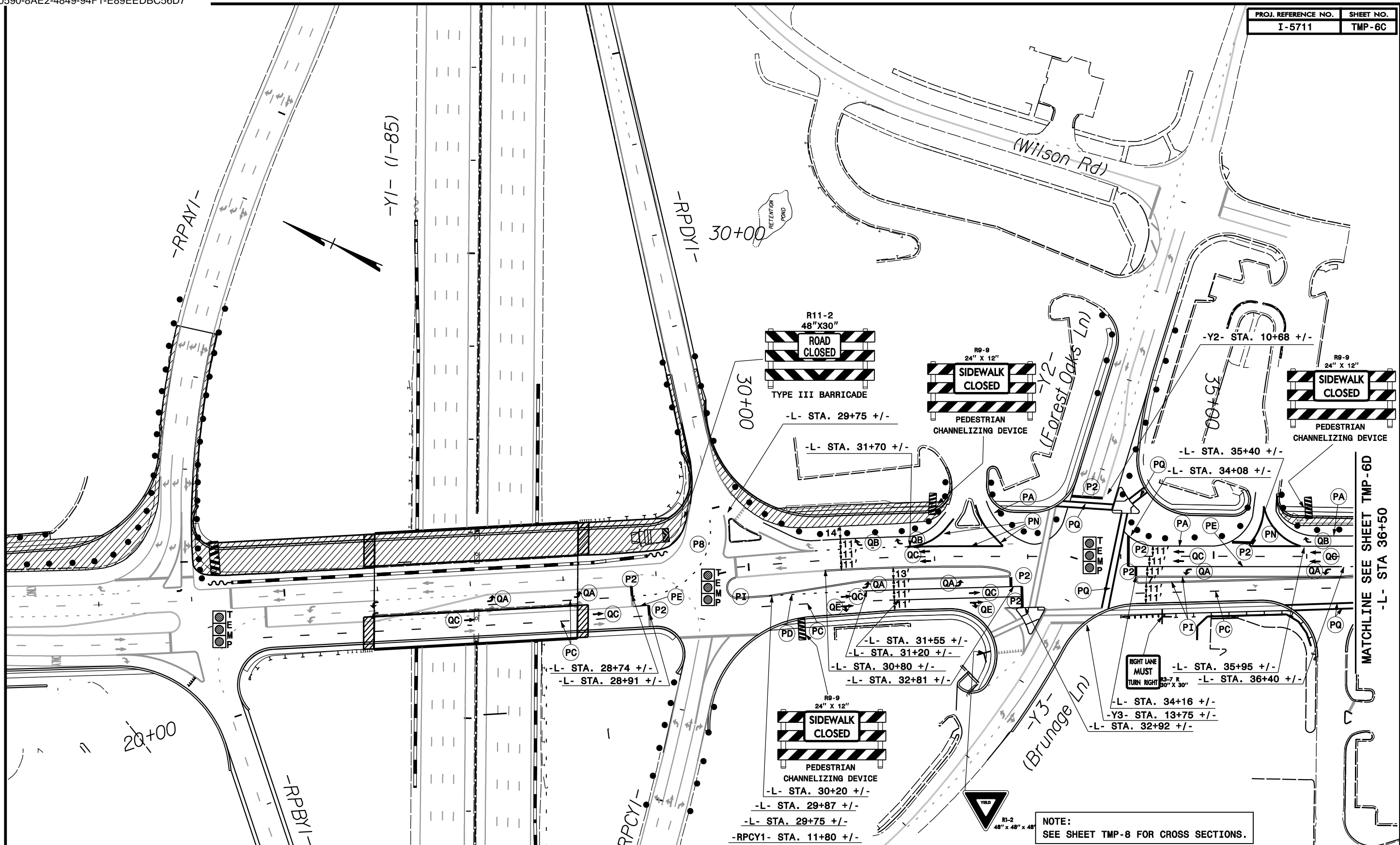

LEGEND	
	WORK AREA
	ON-GOING CONSTRUCTION

PLAN PREPARED IN THE OFFICE OF:

PROGRESSIVE DESIGN GROUP, INC.

ENGINEERS • CONSULTANTS

APPROVED: *Tim Arey*

DATE: 2/26/2020

SEAL

SEAL

ENGINEER
TIM AREY
025465

DOCUMENT NOT CONSIDERED FINAL
UNLESS ALL SIGNATURES COMPLETED

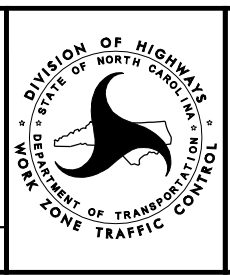

**TRANSPORTATION
MANAGEMENT PLAN
PHASE IIA DETAILS**

NOTE:
SEE SHEET TMP-8 FOR CROSS SECTIONS.

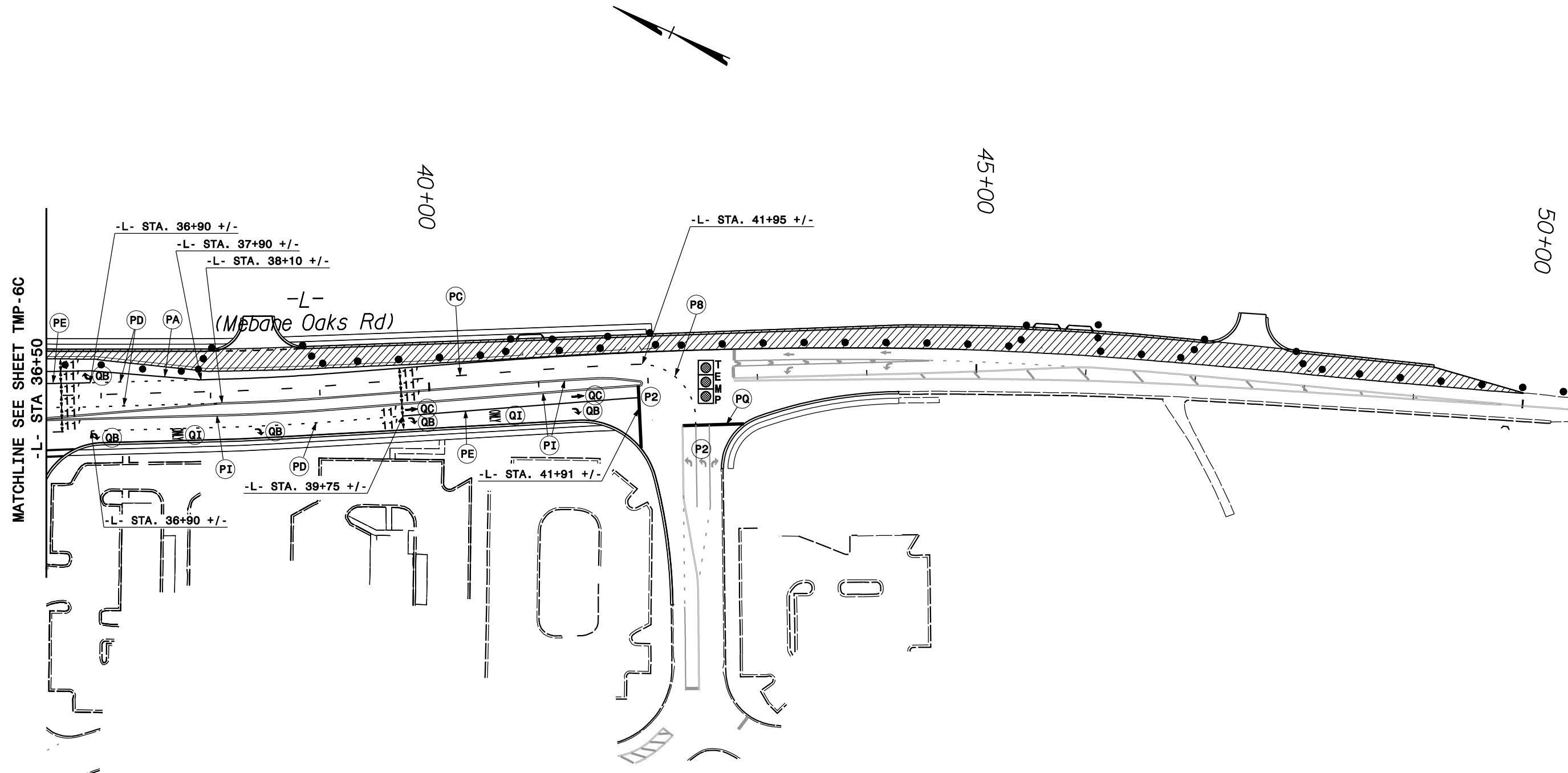

LEGEND	
	WORK AREA
	ON-GOING CONSTRUCTION

PLAN PREPARED IN THE OFFICE OF:
PROGRESSIVE
 DESIGN GROUP, INC.
 ENGINEERS • CONSULTANTS

APPROVED: *Tim Arey*
 DATE: 2/26/2020

SEAL

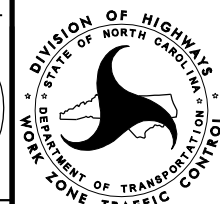

TRANSPORTATION
 MANAGEMENT PLAN
 PHASE IIA DETAILS

DOCUMENT NOT CONSIDERED FINAL
 UNLESS ALL SIGNATURES COMPLETED

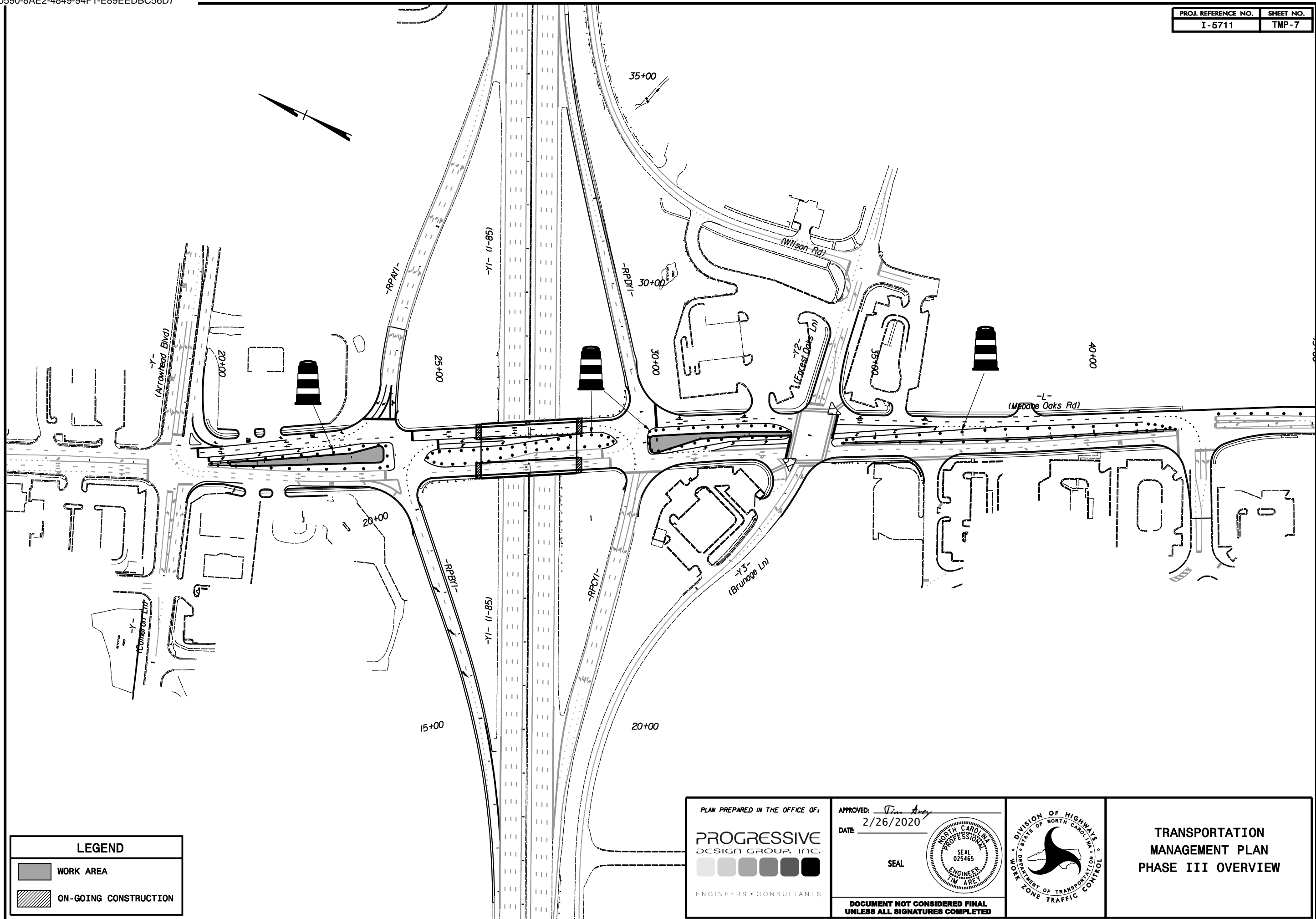

LEGEND	
	WORK AREA
	ON-GOING CONSTRUCTION

PLAN PREPARED IN THE OFFICE OF:

PROGRESSIVE DESIGN GROUP, INC.

ENGINEERS • CONSULTANTS

APPROVED: *Tim Arey*

DATE: 2/26/2020

SEAL

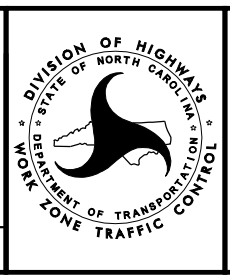

TRANSPORTATION MANAGEMENT PLAN

PHASE III OVERVIEW

DOCUMENT NOT CONSIDERED FINAL UNLESS ALL SIGNATURES COMPLETED

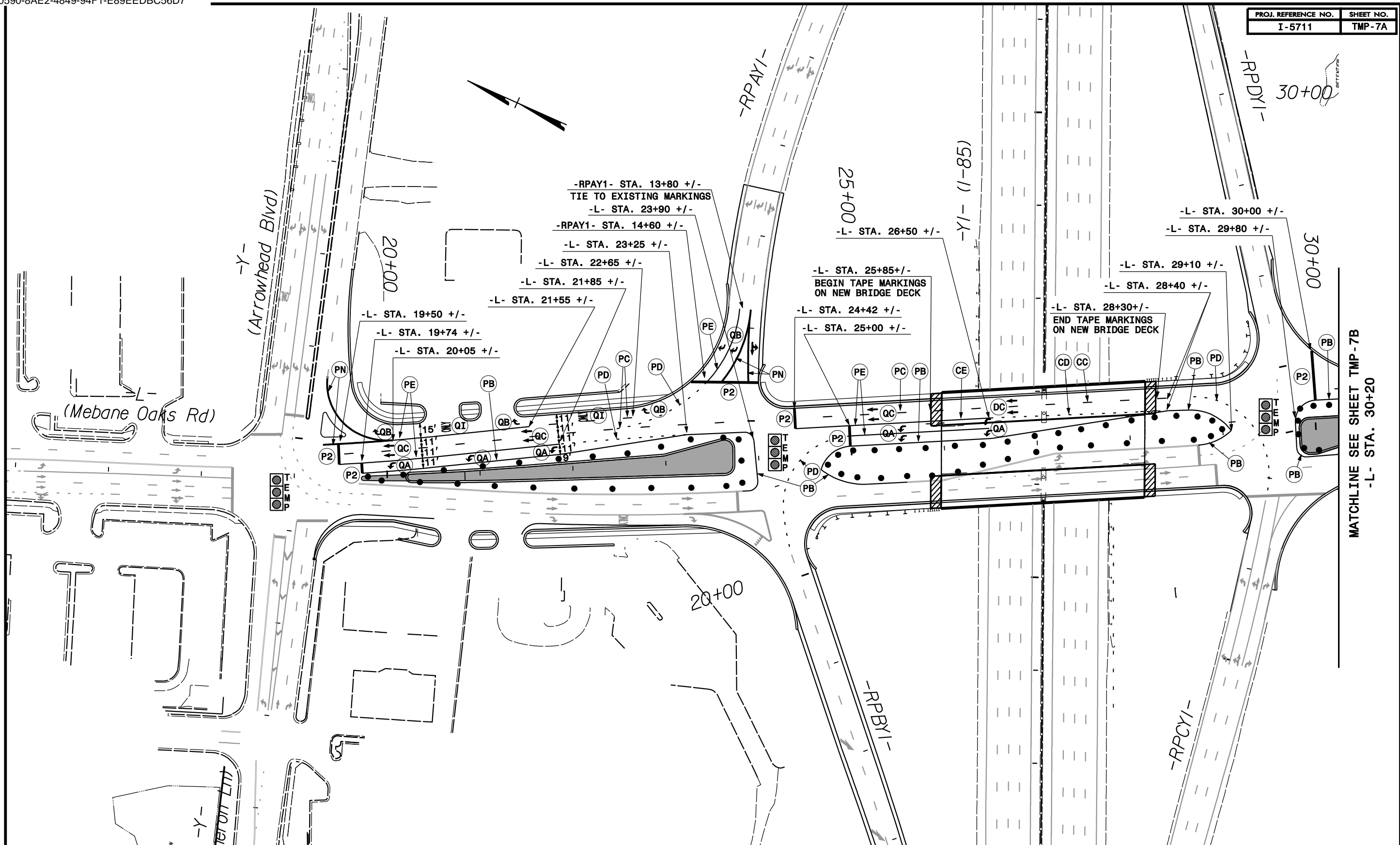

LEGEND	
	WORK AREA
	ON-GOING CONSTRUCTION

PLAN PREPARED IN THE OFFICE OF: PROGRESSIVE DESIGN GROUP, INC. ENGINEERS • CONSULTANTS	APPROVED: <i>Tim Arey</i> DATE: 2/26/2020			TRANSPORTATION MANAGEMENT PLAN PHASE III DETAILS
	SEAL			

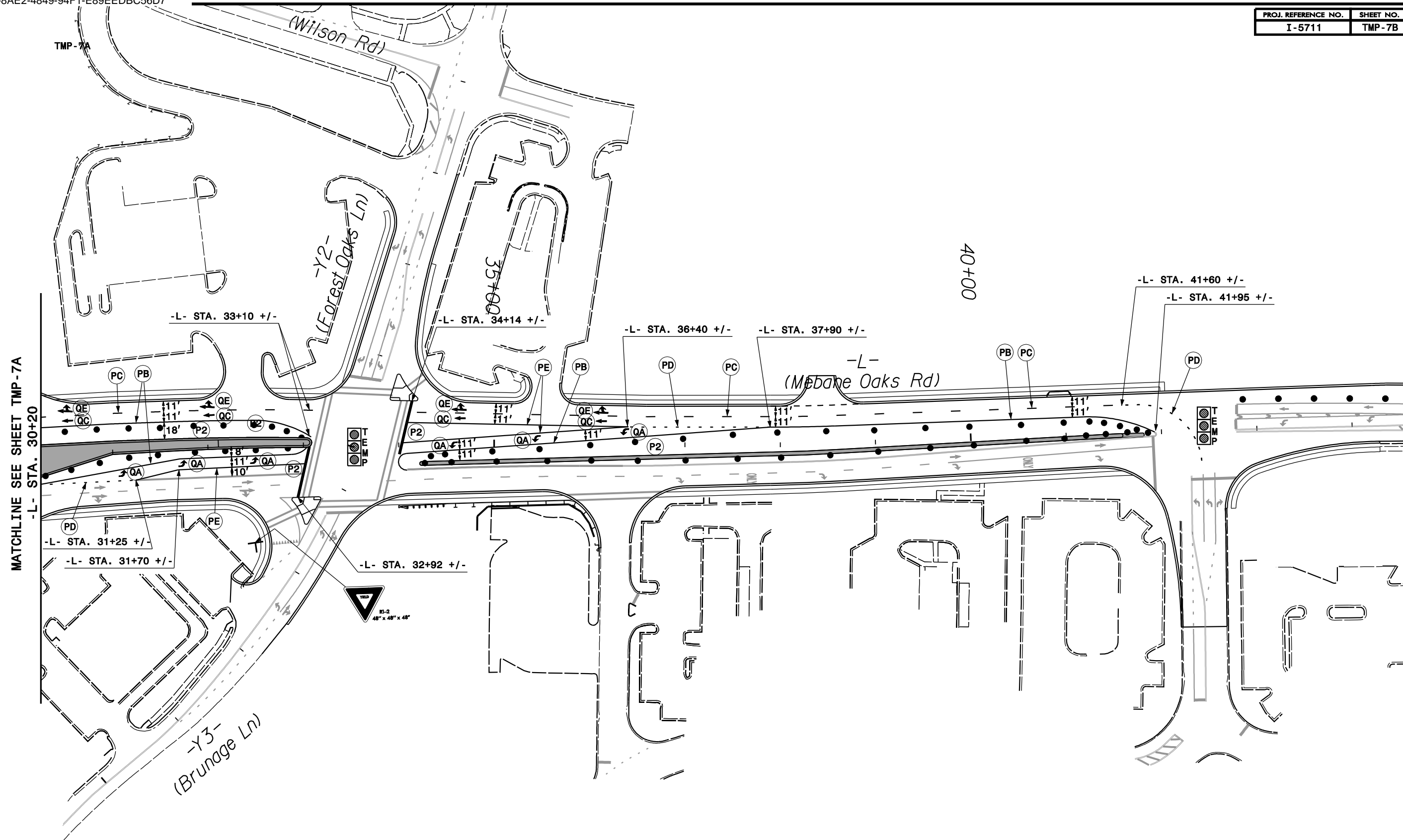

MATCHLINE SEE SHEET TMP-7A

LEGEND	
	WORK AREA
	ON-GOING CONSTRUCTION

<p>PLAN PREPARED IN THE OFFICE OF:</p> <p>PROGRESSIVE DESIGN GROUP, INC.</p> <p>ENGINEERS • CONSULTANTS</p>	<p>APPROVED: <i>Tim Arey</i></p> <p>DATE: 2/26/2020</p>			<p>TRANSPORTATION MANAGEMENT PLAN</p> <p>PHASE III DETAILS</p>
	<p>SEAL</p>			

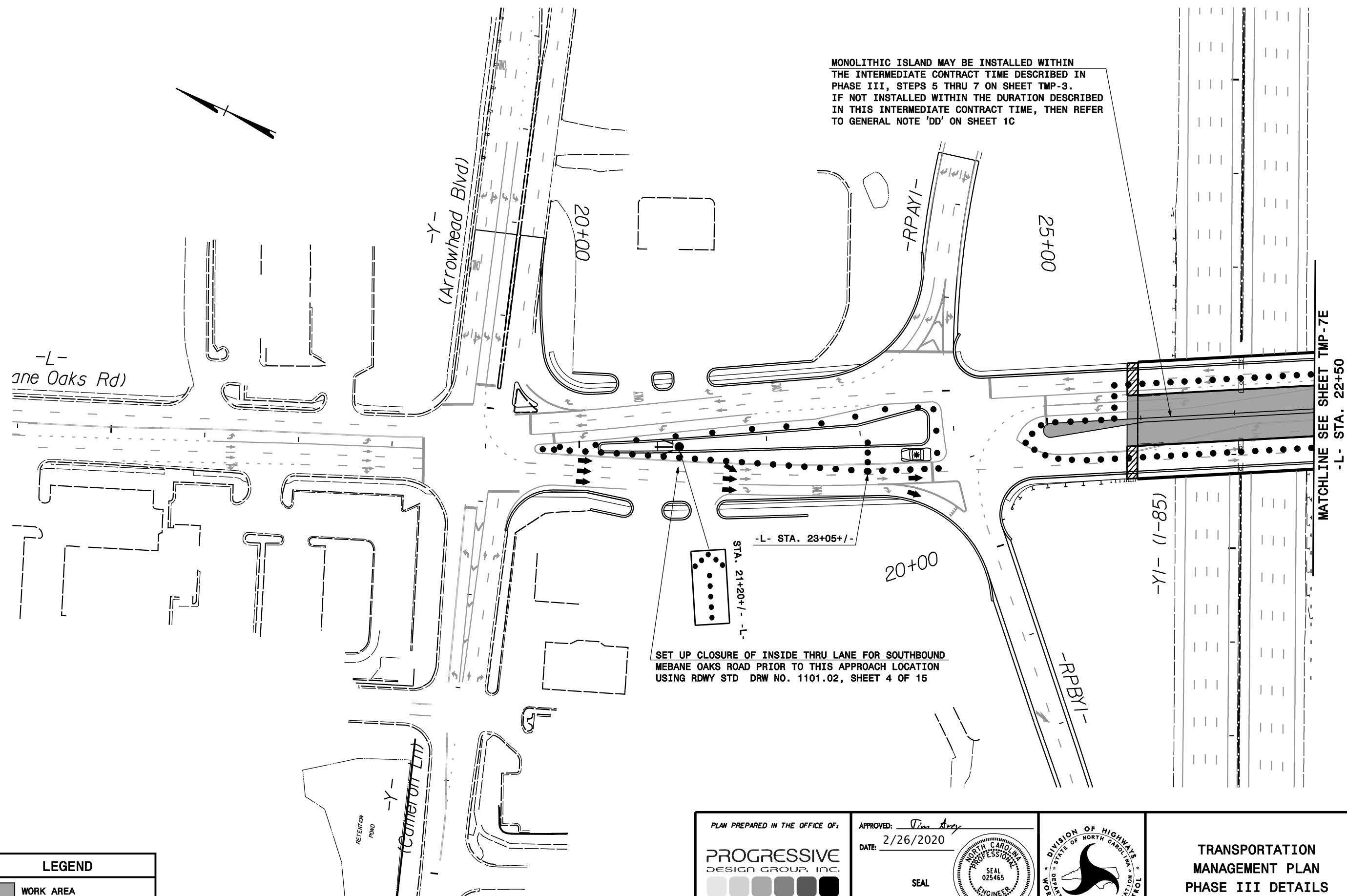

SET UP CLOSURE OF INSIDE THRU LANE FOR SOUTHBOUND MEBANE OAKS ROAD PRIOR TO THIS APPROACH LOCATION USING RDWY STD DRW NO. 1101.02, SHEET 4 OF 15

LEGEND	
	WORK AREA
	ON-GOING CONSTRUCTION

PLAN PREPARED IN THE OFFICE OF:

PROGRESSIVE DESIGN GROUP, INC.

ENGINEERS • CONSULTANTS

APPROVED: *Tim Arrey*

DATE: 2/26/2020

SEAL

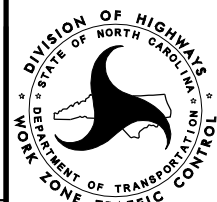
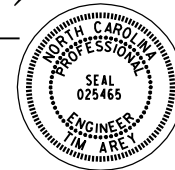

TRANSPORTATION MANAGEMENT PLAN
PHASE III DETAILS
STEPS 5-7

DOCUMENT NOT CONSIDERED FINAL UNLESS ALL SIGNATURES COMPLETED

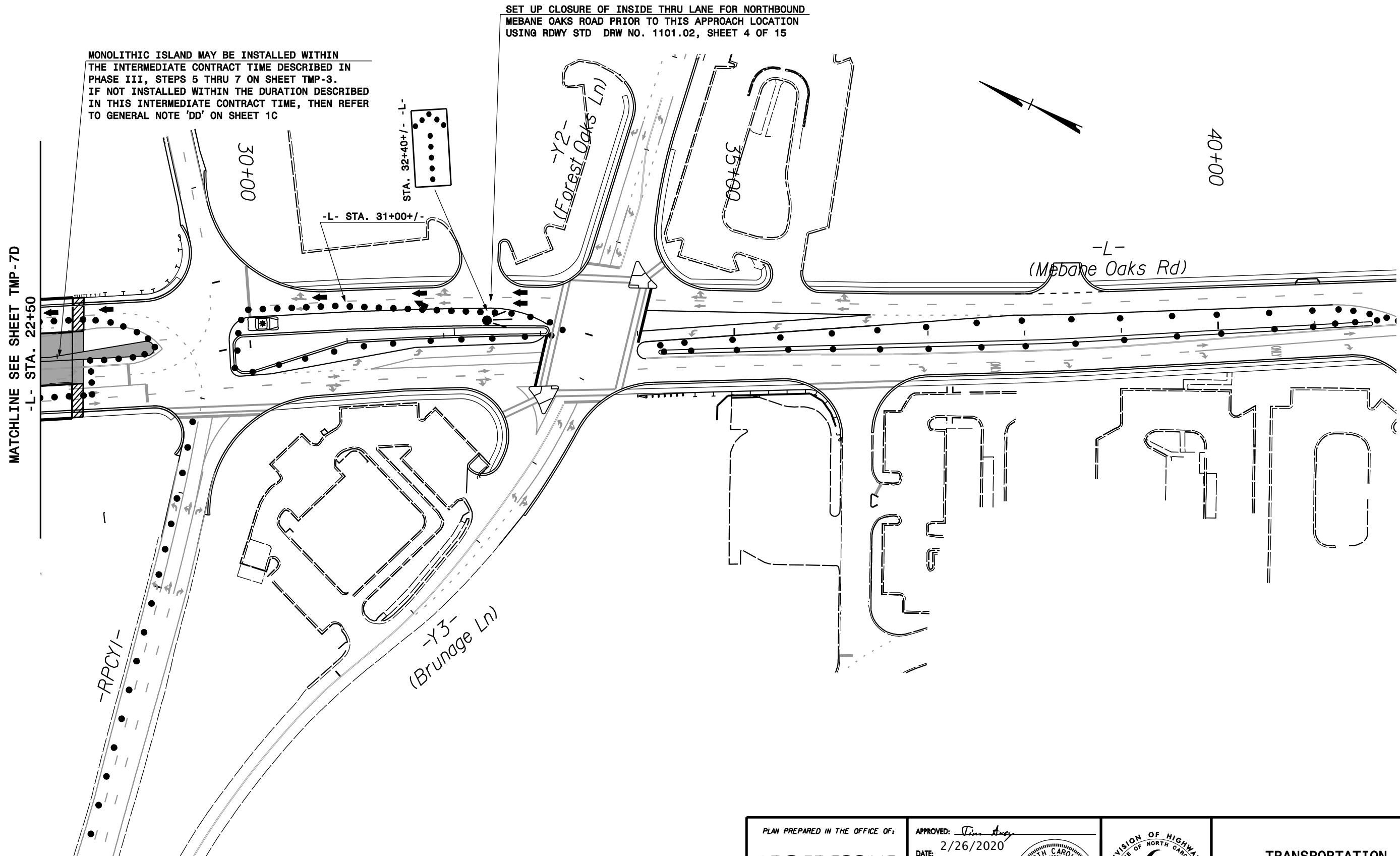

LEGEND	
	WORK AREA
	ON-GOING CONSTRUCTION

PLAN PREPARED IN THE OFFICE OF: PROGRESSIVE DESIGN GROUP, INC. ENGINEERS • CONSULTANTS	APPROVED: <i>Tim Arey</i> DATE: 2/26/2020			TRANSPORTATION MANAGEMENT PLAN PHASE III DETAILS STEPS 5-7
	SEAL			

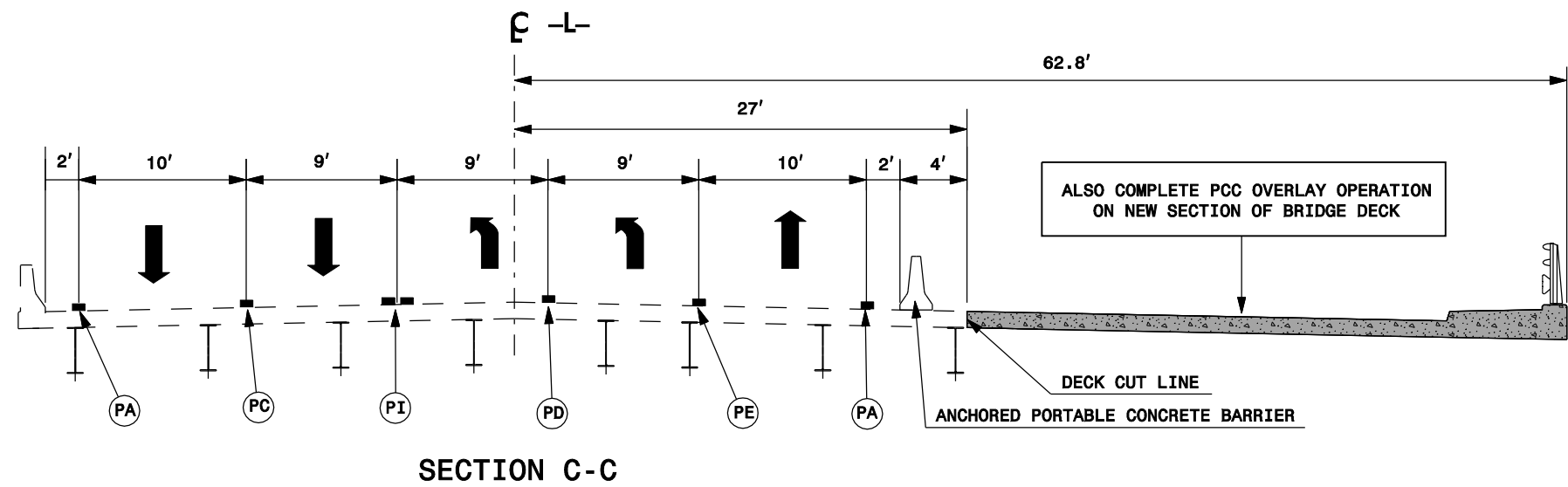
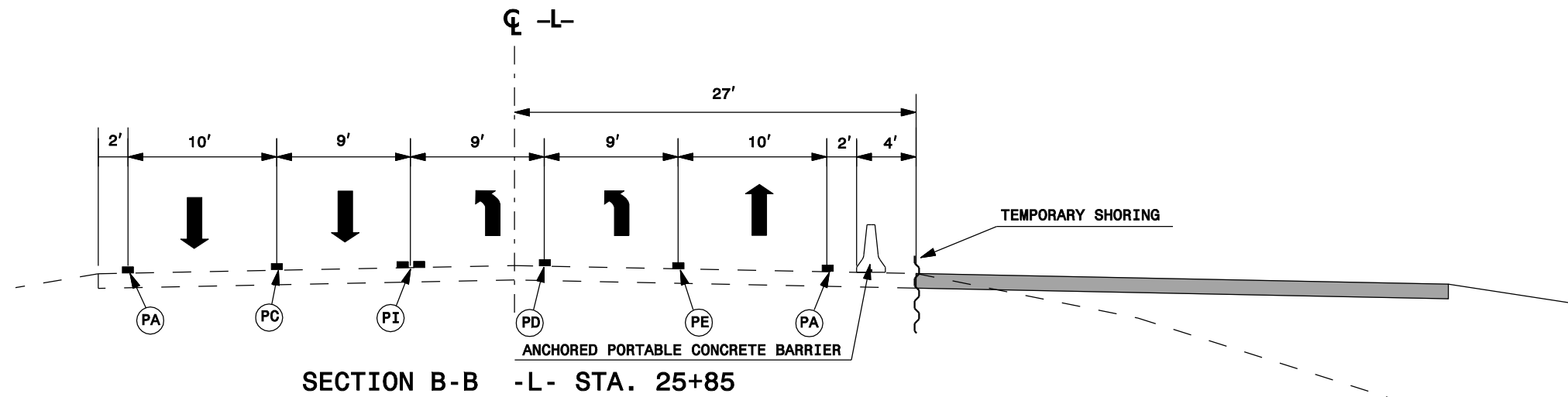
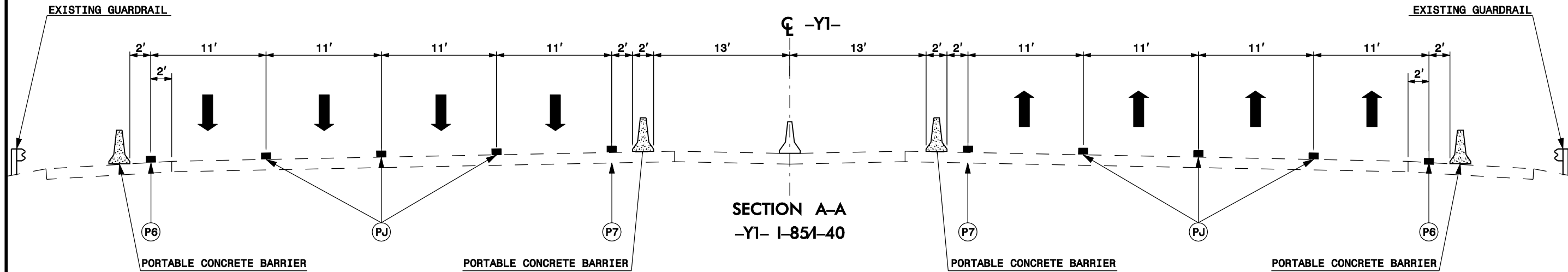

PLAN PREPARED IN THE OFFICE OF:
PROGRESSIVE DESIGN GROUP, INC.
ENGINEERS • CONSULTANTS

APPROVED: *Tim Arey*
DATE: 2/26/2020

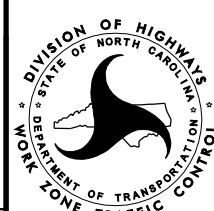
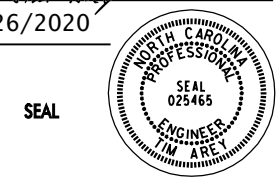

DOCUMENT NOT CONSIDERED FINAL
UNLESS ALL SIGNATURES COMPLETED

TRANSPORTATION
MANAGEMENT PLAN
CROSS SECTIONS

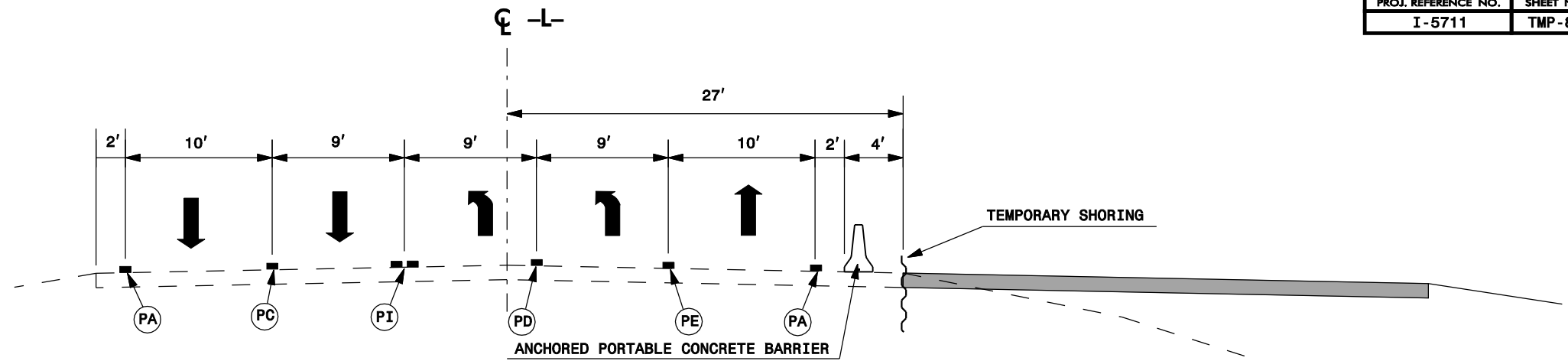

SECTION D-D -L- STA. 28+25

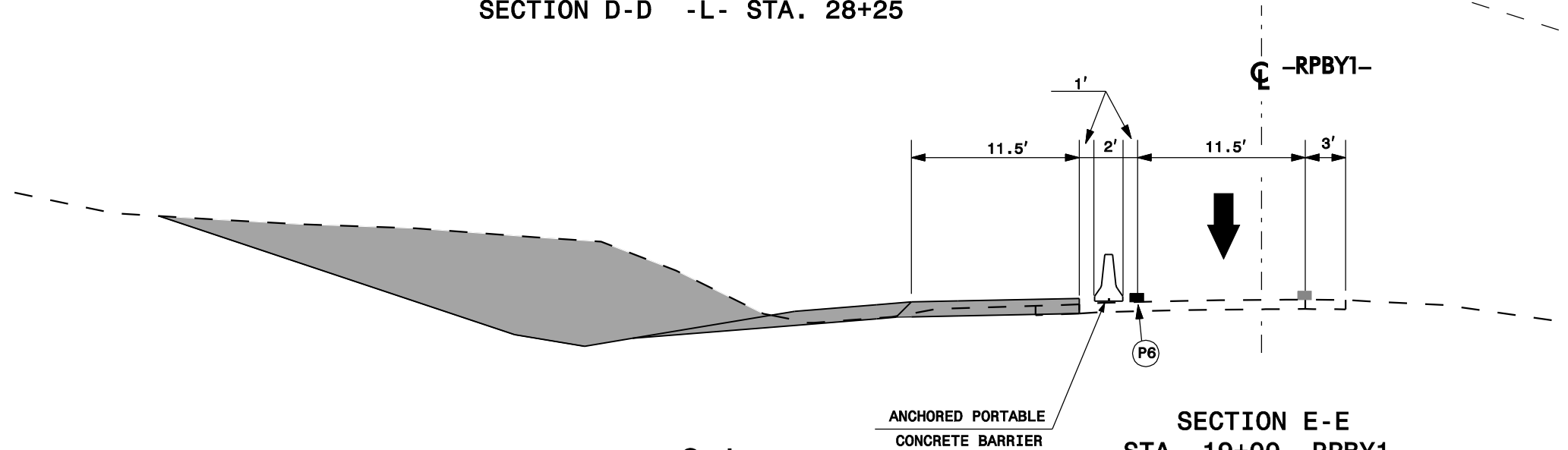

SECTION E-E
STA. 19+00 -RPBY1-

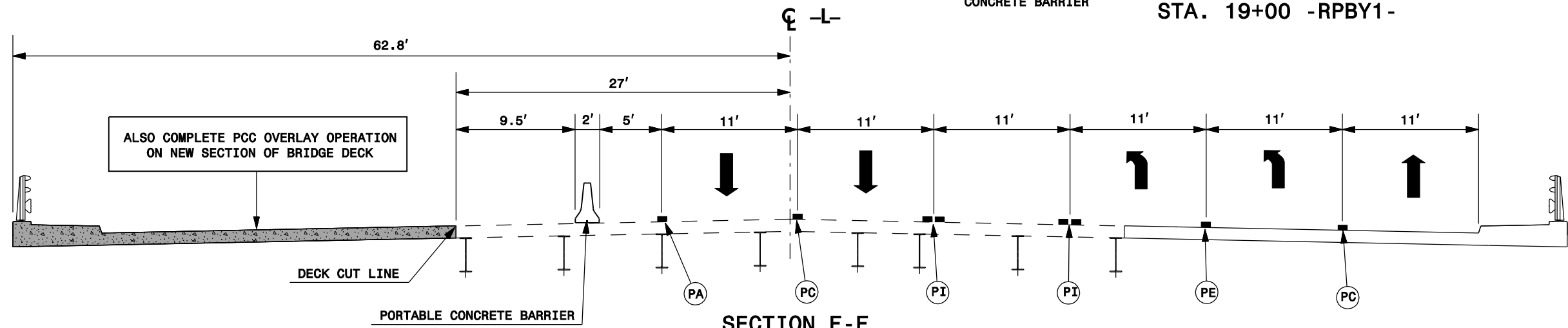

SECTION F-F

PLAN PREPARED IN THE OFFICE OF:
PROGRESSIVE DESIGN GROUP, INC.
ENGINEERS • CONSULTANTS

APPROVED: *Tim Arey*
DATE: 2/26/2020

SEAL

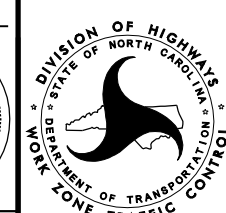
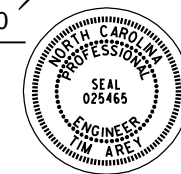

DOCUMENT NOT CONSIDERED FINAL
UNLESS ALL SIGNATURES COMPLETED

TRANSPORTATION
MANAGEMENT PLAN
CROSS SECTIONS