

NOTES

TYPICAL BENT CAP REPAIRS ARE SHOWN. REPAIR DETAILS SIMILAR FOR END BENT CAPS AND STRUTS.

THE METHOD USED TO DELINEATE THE AREAS OF UNSOUND CONCRETE TO BE REPAIRED SHALL NOT PERMANENTLY MARK THE CONCRETE, LEAVE ANY RESIDUE AFTER REMOVAL OR REQUIRE HARSH CHEMICALS TO REMOVE.

THE CONTRACTOR SHALL REMOVE THE DETERIORATED CONCRETE IN ACCORDANCE WITH THE GUIDELINES SET IN THESE NOTES, IN THE SPECIAL PROVISIONS AND THE STANDARD SPECIFICATIONS.

REMOVE UNSOUND CONCRETE TO THE EXTENT NECESSARY, MINIMUM OF 1" BEHIND REBAR AND MINIMUM OF 2" CLEARANCE TO SAWCUT.

NO MORE THAN ONE-THIRD OF THE CAP OR COLUMN CROSS SECTIONAL AREA SHALL BE REMOVED AT ONE TIME. SHOULD IT BECOME NECESSARY TO REMOVE MORE THAN 33% OF A CAP OR COLUMN CROSS SECTIONAL AREA, NOTIFY THE ENGINEER PRIOR TO PROCEEDING.

SIMULTANEOUS REMOVAL OF UNSOUND CONCRETE MAY BE PERMITTED ON MORE THAN ONE FACE OF A CAP AND/OR COLUMN, IF THE AREAS OF REMOVAL ARE NOT ADJACENT TO OR DIRECTLY OPPOSITE ONE ANOTHER. IF REMOVAL EXTENDS MORE THAN 1 1/2" BEHIND THE MAIN REINFORCING BARS, NOTIFY THE ENGINEER PRIOR TO PROCEEDING.

REINFORCING STEEL WHICH IS DETERMINED BY THE ENGINEER TO BE REPLACED, SHALL BE REMOVED TO A POINT WHERE IT IS SOUND. THE PATCH SHALL EXTEND A SUFFICIENT DISTANCE BEYOND THIS POINT TO DEVELOP A SPLICE LENGTH SPECIFIED IN THE TABLE ON THIS SHEET.

THE #4 "U" DOWELS ARE REQUIRED ONLY AROUND THE ANCHOR BOLTS. THE EXISTING REINFORCING STEEL IN THE PEDESTAL WALL SHALL BE CLEANED, STRAIGHTENED AND REMAIN IN PLACE.

FOR ADHESIVELY ANCHORED ANCHOR BOLTS OR DOWELS, SEE STANDARD SPECIFICATIONS.

COAT ALL REPAIR SURFACE AREAS ON THE TOP OF CAPS, INCLUDING CHAMFERS, WITH EPOXY PROTECTIVE COATING, OVERLAPPING THE REPAIR AREA BY A MINIMUM OF 3" ON ALL POSSIBLE SIDES.

FOR SHOTCRETE REPAIRS, SEE SPECIAL PROVISIONS.

FOR CONCRETE REPAIRS, SEE SPECIAL PROVISIONS.

FOR EPOXY PROTECTIVE COATING, SEE SPECIAL PROVISIONS.

FOR EPOXY RESIN INJECTION (ERI), SEE SPECIAL PROVISIONS.

PROJECT NO. I-5769
MECKLENBURG COUNTY
 BRIDGE NO. 590221, 590222,
590227, 590230, 590231, 590241, 590243

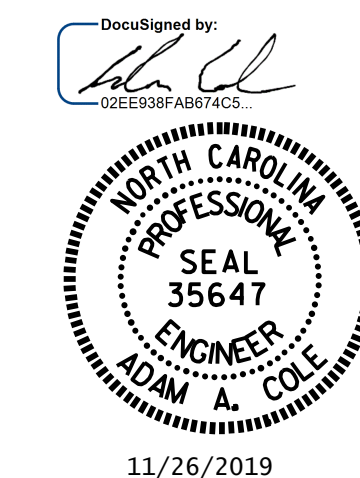

STATE OF NORTH CAROLINA
 DEPARTMENT OF TRANSPORTATION
 RALEIGH
 STANDARD
 TYPICAL CAP
 AND COLUMN
 REPAIR DETAILS

REVISIONS						SHEET NO.
NO.	BY:	DATE:	NO.	BY:	DATE:	SD-02
1			3			TOTAL SHEETS
2			4			3

DOCUMENT NOT CONSIDERED FINAL UNLESS ALL SIGNATURES COMPLETED

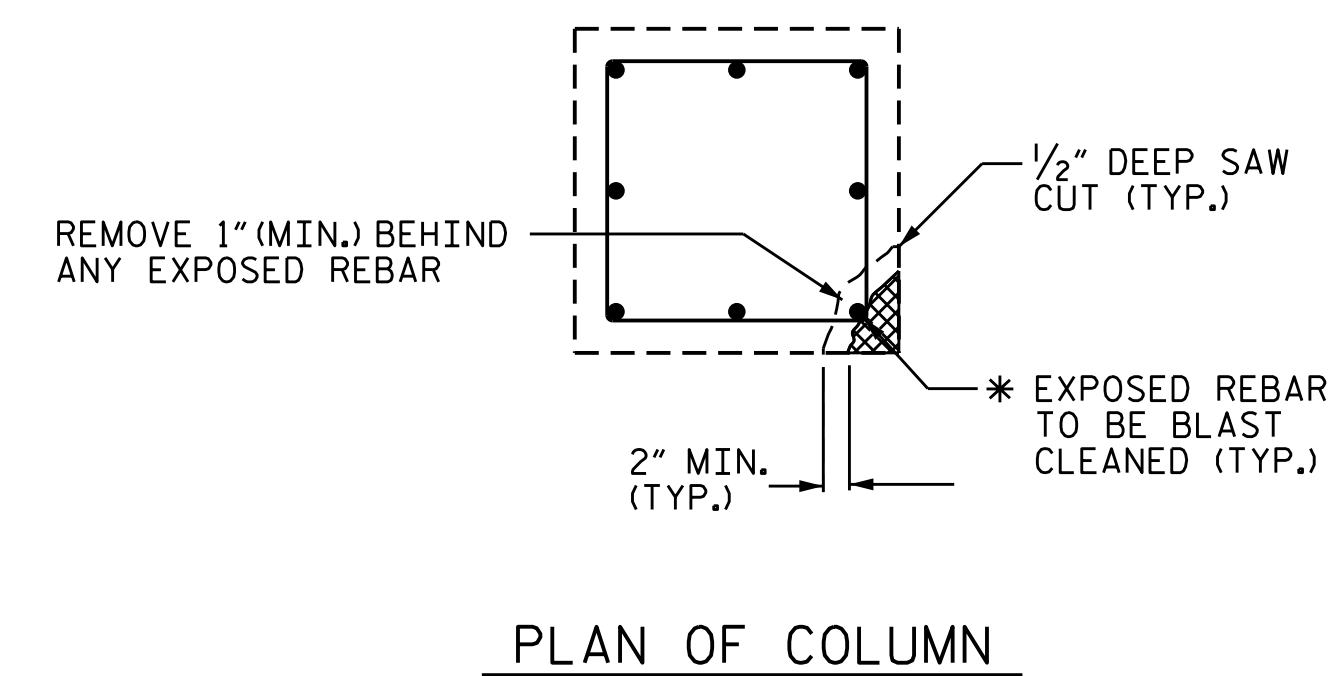
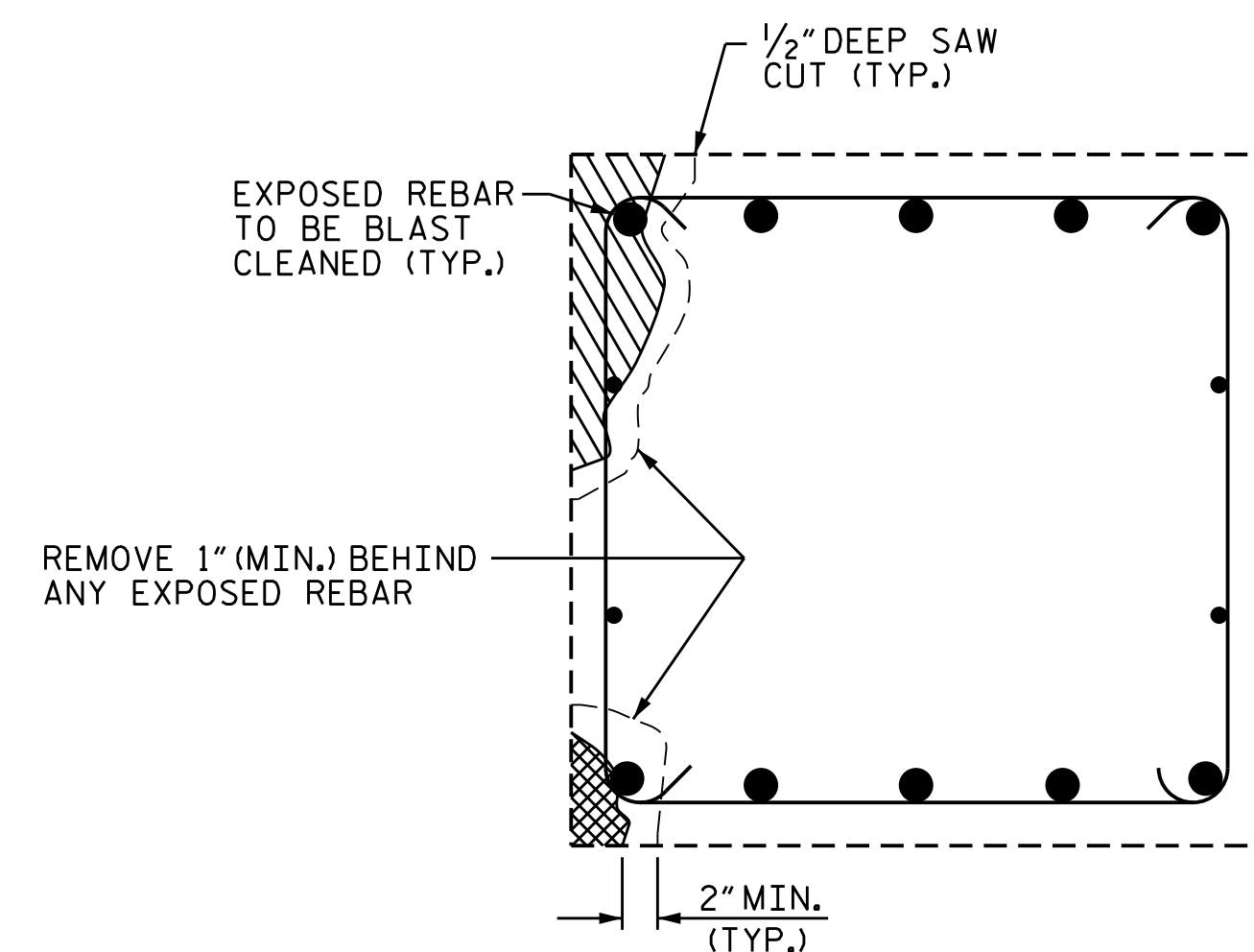
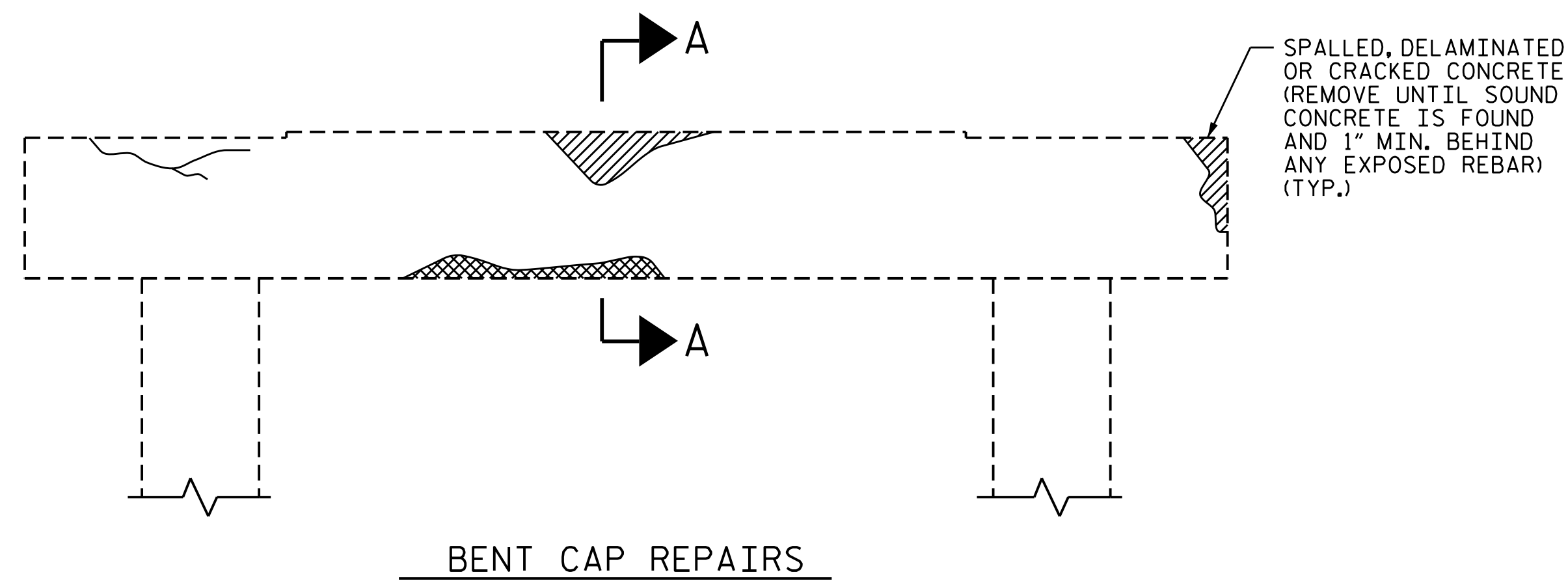

REPAIR KEY

- CONCRETE REPAIR AREA (FORM AND POUR)
- SHOTCRETE REPAIR AREA
- EPOXY RESIN INJECTION (ERI)

SECTION A-A
CAP REPAIR

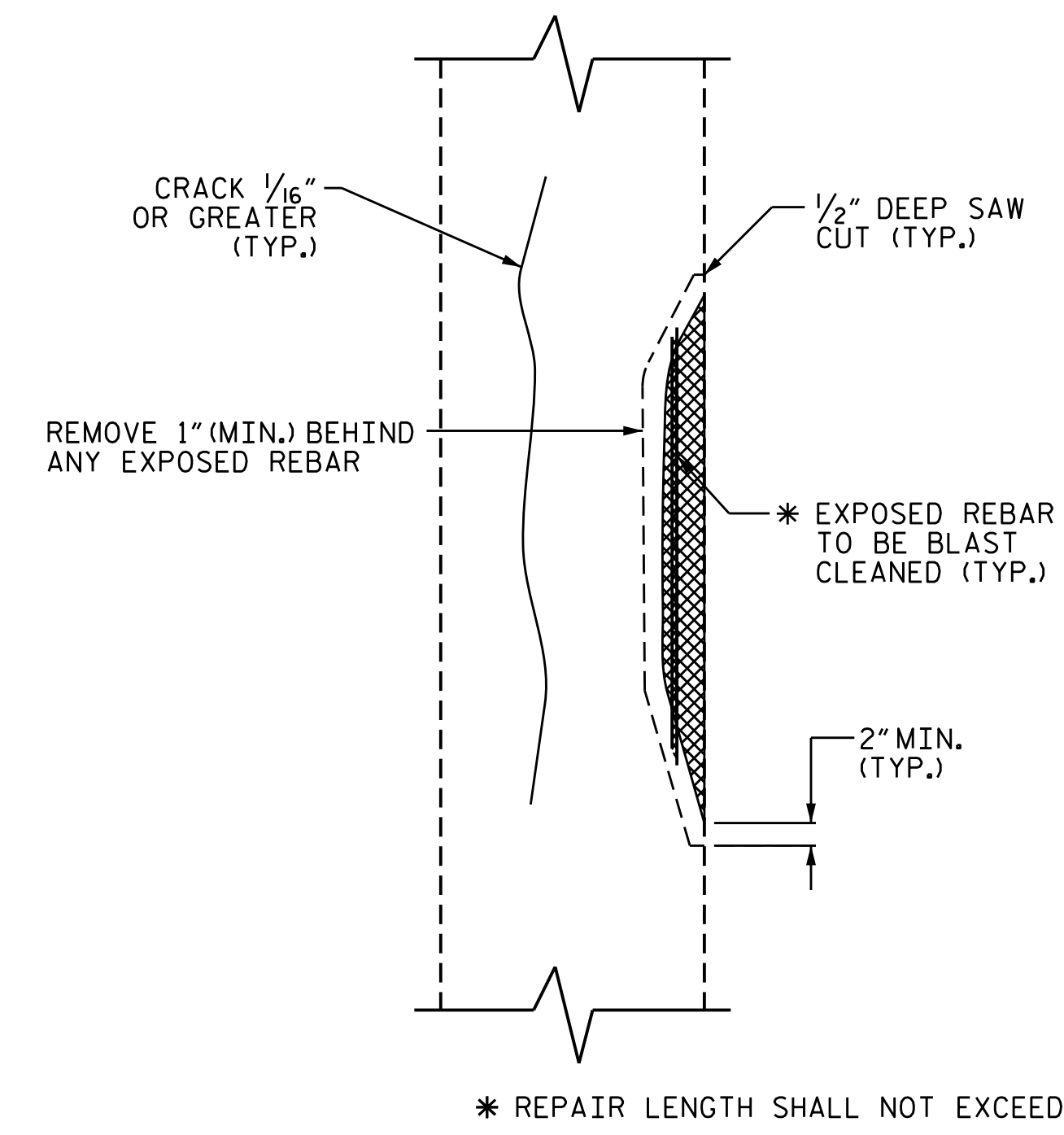

SPLICE LENGTH TABLE

BAR SIZE	MIN. SPLICE LENGTH
#4	2'-4"
#5	2'-9"
#6	4'-0"
#7	5'-3"
#8	6'-9"
#9	8'-6"
#10	10'-11"
#11	13'-4"

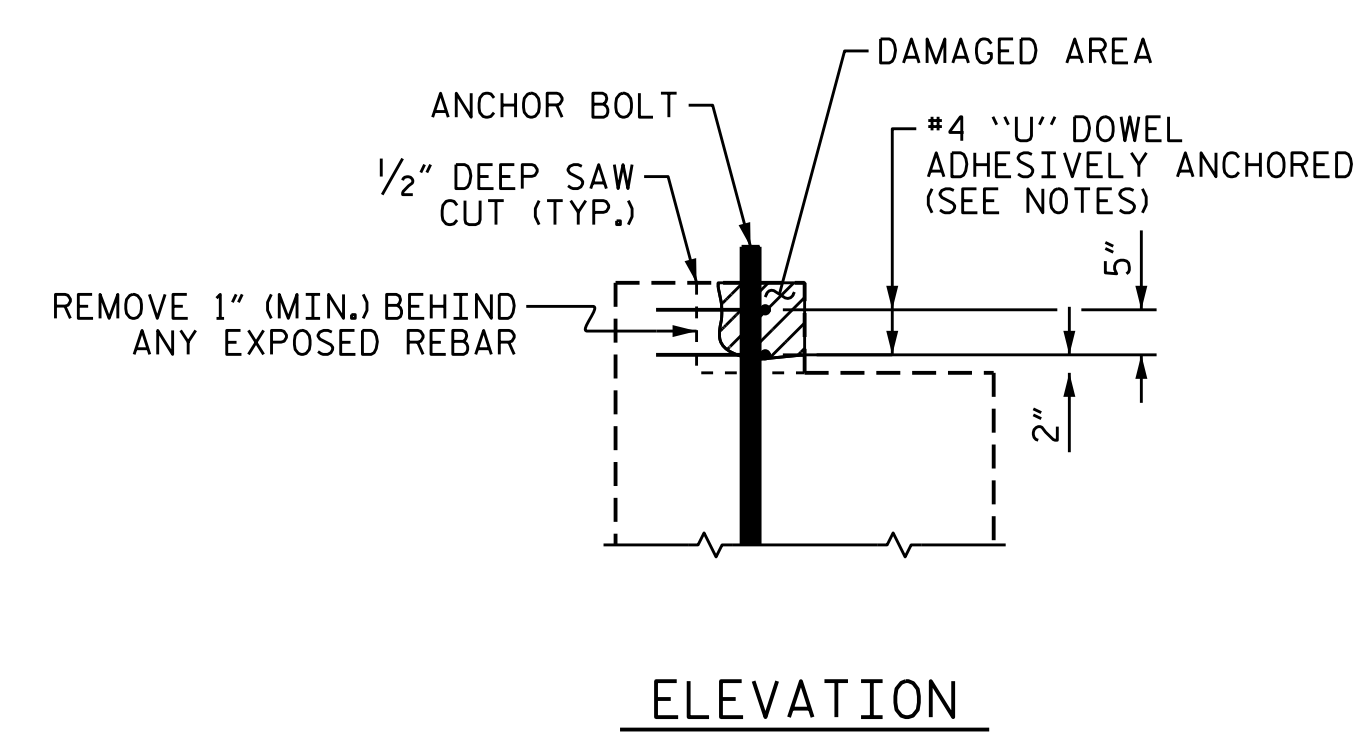
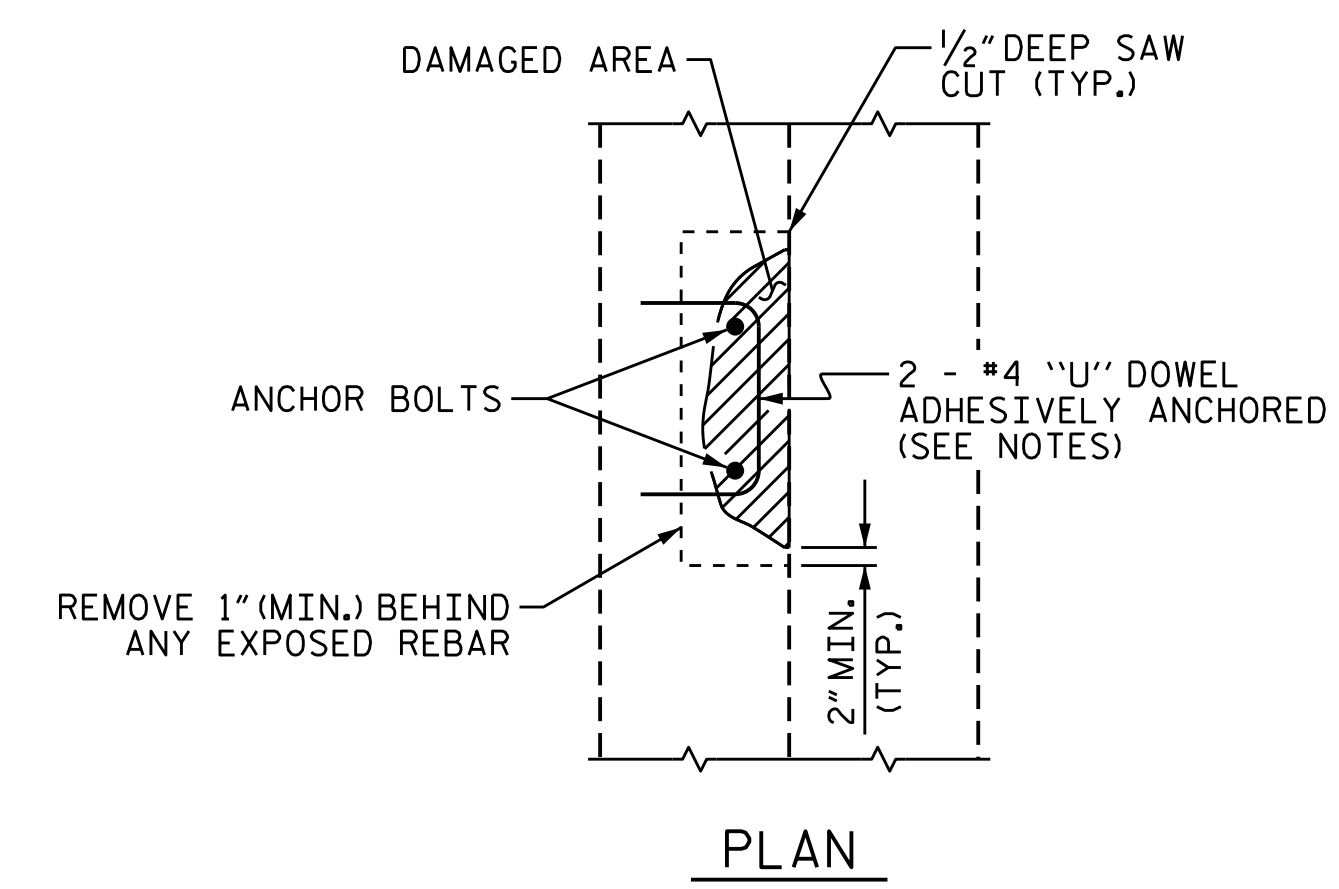

PEDESTAL WALL REPAIR

ELEVATION OF COLUMN
COLUMN REPAIR

* REPAIR LENGTH SHALL NOT EXCEED 10 FEET.

ASSEMBLED BY : R. SAHA DATE : 8/2019
 CHECKED BY : H.A. LOCKLEAR DATE : 9/2019
 DRAWN BY : NAP 8/18
 CHECKED BY :