

CONTRACT: C204210 T.I.P.: R-2582A

**STATE OF NORTH CAROLINA
DEPARTMENT OF TRANSPORTATION**

**SIGNING PLAN
NORTHAMPTON COUNTY & HALIFAX COUNTY
LOCATION: PROPOSED US 158 FROM I-95 EXIT 176 (NC 46) TO SR 1312 (ST. JOHN CHURCH RD)
EXISTING US 158 ROUTE CHANGE FROM I-95 EXIT 173 THROUGH WELDON TO GARYSBURG
I-95 BOTH APPROACHES TO EXIT 173 AND EXIT 176**

PROJECT REFERENCE NO. R-2582A	SHEET NO. SIGN-1
APPROVED: <small>DocuSigned by: Zhaolong Teng #868A0E527455</small>	
DATE: 8/13/2020	
DOCUMENT NOT CONSIDERED FINAL UNLESS ALL SIGNATURES COMPLETED	

SUMMARY OF QUANTITIES

ITEM NO.		ITEM DESCRIPTION	QUANTITY	UNIT
DESC. NO.	SECT. NO.			
4048000000	902	REINFORCED CONCRETE SIGN FOUNDATION	36	C.Y.
4054000000	902	PLAIN CONCRETE SIGN FOUNDATION	1	C.Y.
4057000000	SP	OVERHEAD FOOTING	41	C.Y.
4060000000	903	SUPPORTS, BREAKAWAY STEEL BEAM	20262	LB.
4066000000	903	SUPPORTS, SIMPLE STEEL BEAM	14824	LB.
4072000000	903	SUPPORTS, 3 LB STEEL U-CHANNEL	7700	L.F.
4096000000	904	SIGN ERECTION, TYPE D	18	EA.
4102000000	904	SIGN ERECTION, TYPE E	233	EA.
4108000000	904	SIGN ERECTION, TYPE F	102	EA.
4109000000	904	SIGN ERECTION, TYPE A (OVERHEAD)	4	EA.
4109000000	904	SIGN ERECTION, TYPE B (OVERHEAD)	2	EA.
4110000000	904	SIGN ERECTION, TYPE A (GROUND MOUNTED)	19	EA.
4110000000	904	SIGN ERECTION, TYPE B (GROUND MOUNTED)	10	EA.
4116100000	904	SIGN ERECTION, RELOCATE SIGN TYPE A (GROUND MOUNTED)	2	EA.
4116100000	904	SIGN ERECTION, RELOCATE SIGN TYPE D (GROUND MOUNTED)	3	EA.
4082100000	906	SUPPORTS, OVERHEAD SIGN STRUCTURE @ I-95 NB EXIT 173	1	L.S.
4082100000	906	SUPPORTS, OVERHEAD SIGN STRUCTURE @ I-95 SB EXIT 176	1	L.S.
4138000000	907	DISPOSAL OF SUPPORT, STEEL BEAM	1	EA.
4141000000	907	DISPOSAL OF SUPPORT, WOOD	4	EA.
4152000000	907	DISPOSAL OF SIGN SYSTEM, STEEL BEAM	13	EA.
4155000000	907	DISPOSAL OF SIGN SYSTEM, U-CHANNEL	56	EA.
4158000000	907	DISPOSAL OF SIGN SYSTEM, WOOD	86	EA.
4915000000	1264	7' U-CHANNEL POSTS	8	EA.
4955000000	1264	OBJECT MARKERS (END OF ROAD)	8	EA.
4957000000	1264	OBJECT MARKERS (TYPE 1)	11	EA.

GENERAL NOTES

- . SIGNS FURNISHED BY STATE
- . CONFIRM IN WRITING AT LEAST 4 MONTHS IN ADVANCE, THE ACTUAL DATE THE DEPARTMENT FURNISHED SIGNS WILL BE REQUIRED.
- . ALL TYPE 'D' SIGNS SHALL BE MOUNTED ON TWO U-CHANNEL POSTS UNLESS OTHERWISE INDICATED ON THE PLANS.
- . IF REMOVAL OR RELOCATION OF SIGNS ON PRIVATE STREET (NON-STATE MAINTAINED) IS REQUIRED DUE TO CONSTRUCTION, THE CONTRACTOR SHALL INFORM THE ENGINEER. THE WORK WILL BE COMPLETED BY OTHERS.
- . WHEN NOT STATIONED OR DIMENSIONED ON PLANS, ALL 'E' AND 'F' SIGNS SHALL BE FIELD LOCATED BY THE ENGINEER
- . ALL EXISTING SIGNS ON WOOD OR "U" CHANNEL POST WITHIN THE PROJECT LIMITS SHALL BE REMOVED AND DISPOSED OF UNLESS OTHERWISE NOTED ON PLANS.
- . WHEN EXISTING SIGNS ARE REMOVED AND INSTALLED ON NEW SUPPORTS, THE RE-ERECTION SHALL IMMEDIATELY FOLLOW THE REMOVAL.
- . THE BACKGROUND FOR TYPE E & F SIGNS SHALL BE TYPE C REFLECTIVE SHEETING.
- . DO NOT BEGIN FABRICATION FOR TYPES A & B SIGNS MOUNTED ON OVERHEAD STRUCTURES OR STEEL SUPPORTS UNTIL "S" DIMENSIONS HAVE BEEN FIELD VERIFIED.
- . SEE ROADWAY PLANS FOR GUARD/GUIDE RAIL DETAILS.

ROADWAY STANDARD DRAWING

THE FOLLOWING ROADWAY STANDARDS AS APPEAR IN "ROADWAY STANDARD DRAWINGS" - PROJECT SERVICES UNIT - N.C. DEPARTMENT OF TRANSPORTATION - RALEIGH, N.C., DATED JANUARY 2018 ARE APPLICABLE TO THIS PROJECT AND BY REFERENCE HEREBY ARE CONSIDERED A PART OF THESE PLANS:

STD. NO.	TITLE
901.10	TYPE 'A' SIGNS
901.20	TYPE 'B' SIGNS
901.50	ARROWS AND SHIELDS
901.70	SIGN STRINGERS AND SUPPORT SPACING
901.80	SIGN MOUNTING DETAILS - FOR TYPE A AND TYPE B SIGNS
903.10	GROUND MOUNTED SIGN SUPPORTS
903.20	WOOD SIGN SUPPORTS
904.10	ORIENTATION OF GROUND MOUNTED SIGNS
904.20	SECONDARY SIGN MOUNTING
904.50	MOUNTING OF TYPE 'D', 'E' AND 'F' SIGNS ON 'U' CHANNEL POSTS
910.30	SIGNING SIGNALIZED AND UNSIGNALIZED SUPERSTREET
910.40	SINGLE/TWO LANE ROUNDABOUT WITH PEDESTRIAN
910.50	SIGNING FOR SPEED REDUCTION ZONE
1264.01	OBJECT MARKERS (TYPES)
1264.02	OBJECT MARKERS (INSTALLATION)

PROJECT NOTES

- 1A RELOCATE SIGN, TYPE A (GROUND MOUNTED)
- 1B RELOCATE SIGN, TYPE B (GROUND MOUNTED)
- 1C RELOCATE SIGN, TYPE D
- 2A DISPOSAL OF SUPPORT, STEEL BEAM
- 2B DISPOSAL OF SUPPORT, WOOD
- 2C DISPOSAL OF SIGN SYSTEM, STEEL BEAM
- 2D DISPOSAL OF SIGN SYSTEM, U-CHANNEL
- 2E DISPOSAL OF SIGN SYSTEM, WOOD
- 2F DISPOSAL OF SUPPORT, U-CHANNEL
- 3A SIGN ERECTION, TYPE A (OVERHEAD)
- 3B SIGN ERECTION, TYPE B (OVERHEAD)
- 3C SIGN ERECTION, TYPE A (GROUND MOUNTED)
- 3D SIGN ERECTION, TYPE B (GROUND MOUNTED)
- 3E SIGN ERECTION, TYPE D, E, AND F
- 4A SIGN ERECTION, RELOCATE SIGN TYPE A (GROUND MOUNTED)
- 4B SIGN ERECTION, RELOCATE SIGN TYPE B (GROUND MOUNTED)
- 4C SIGN ERECTION, RELOCATE SIGN TYPE D

This plan supersedes the plan signed and sealed on 3/20/2019.

INDEX

SHEET NO.	DESCRIPTION
SIGN-1	TITLE SHEET
SIGN-2	SUPPORT INFORMATION
SIGN-2A & 2B	STRUCTURE LINE DRAWINGS
SIGN-3 - 3D	E AND F SHEETS
SIGN-4-4I	SIGN DESIGNS
SIGN-5-29	SIGNING PLAN SHEETS

PLAN REVIEWED BY: N.C.D.O.T. SIGNING AND DELINEATION UNIT		
<u>AYMAN ALQUDWAH, PE</u> SIGNING & DELINEATION REGIONAL ENGINEER		
<u>STACEY JOHNS</u> SIGNING & DELINEATION PROJECT DESIGN ENGINEER		

PLAN PREPARED BY:		ACCELERATE ENGINEERING, PLLC
<u>ZHAOLONG (GAVIN) TENG, PE, PTOE</u> PROJECT MANAGER		 <small>875 Walnut Street, Suite 316 Cary, NC 27511 Tel: 919.263.5678 Fax: 919.263.5687 NC License No. P-1442</small>
<u>ERIC M. THOMAS JR. PE</u> TRANSPORTATION ENGINEER		

PROJECT REFERENCE NO. R-2582A	SHEET NO. SIGN-2A
APPROVED: <i>Zhaolong Teng</i> 6868A0DE5297455	
DATE: 3/20/2019	
SEAL 	
DOCUMENT NOT CONSIDERED FINAL UNLESS ALL SIGNATURES COMPLETED	
<small>PREPARED IN THE OFFICE OF:</small>  Accelerate Engineering, PLLC 875 Walnut Street, Suite 316 Cary, NC 27511 Tel: 919.263.5678 Fax: 919.263.5687 NC License No. P-1442	

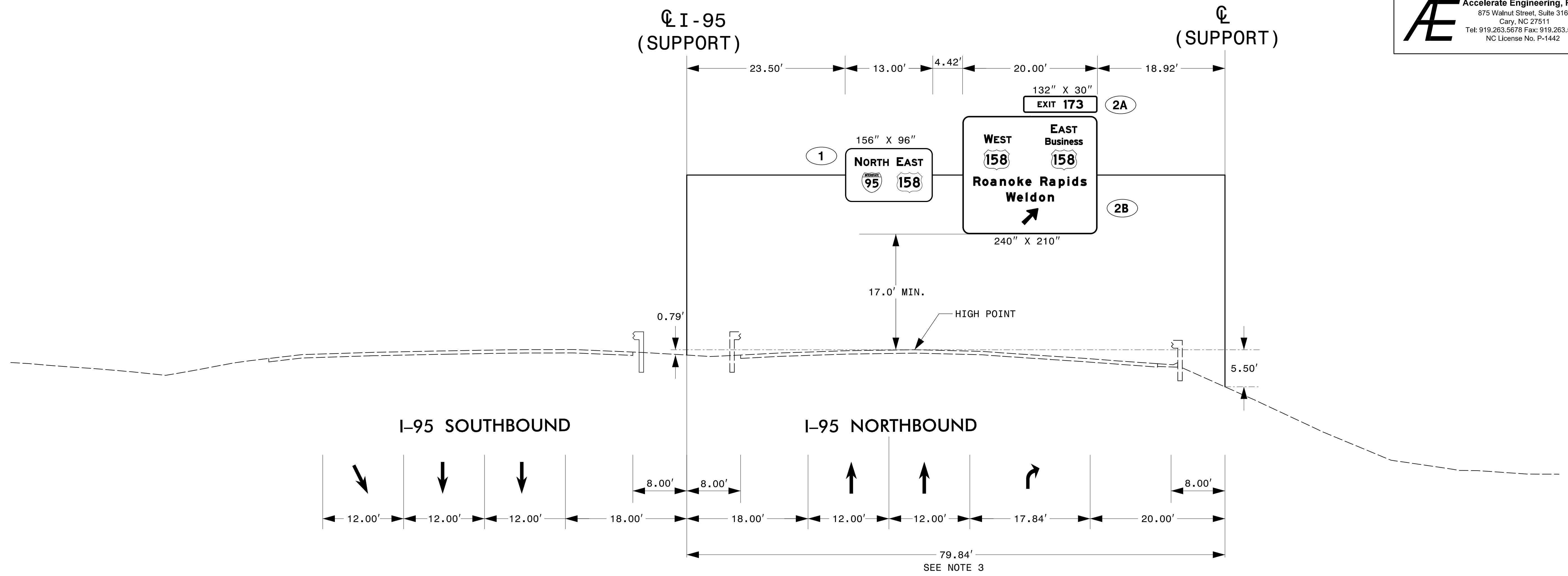

NOTES:

1. IF THE CONTRACTOR BIDS ALUMINUM SIGN STRUCTURE, EACH SHALL BE PROVIDED WITH AN APPROVED HIGHWAY TRUSS DAMPER DEVICE IN ACCORDANCE WITH AASHTO SPECIFICATIONS.
2. MOUNT SIGNS VERTICALLY CENTERED ON HORIZONTAL MEMBER OF STRUCTURE.
3. DIMENSIONS SHOWN ON THIS PLAN ARE ESTIMATED FOR PROJECT BID PURPOSES. FIELD VERIFICATION SHALL BE REQUIRED FOR ALL SUPPORT LOCATIONS, SPAN LENGTH AND FOOTING ELEVATIONS, PER THE LATEST NCDOT STANDARD SPECIFICATIONS FOR ROADS AND STRUCTURES. PROVIDE FIELD VERIFICATION TO THE SIGNING SECTION.
4. THE TOP OF THE FOOTING SHALL EXTEND AT LEAST 4 INCHES AND NOT MORE THAN 24 INCHES ABOVE THE HIGHEST POINT OF THE GROUND SURFACE AT THE FOOTING.
5. SIGN HANGERS AND ATTACHMENT HARDWARE SHALL BE PROVIDED AND INSTALLED ON THE ASSEMBLY TO ACCOMMODATE ALL SIGNS SHOWN IN THIS PLAN SHEET.
6. DESIGN AND CONSTRUCTION REQUIREMENTS FOR SIGN STRUCTURES SHALL ACCOMMODATE WIND VELOCITY OF 100 M.P.H.

OVERHEAD SIGN ASSEMBLY 'A'
I-95 EXIT 173

PROJECT REFERENCE NO. R-2582A	SHEET NO. SIGN-2B
APPROVED: <i>Zhaolong Teng</i> 098BA00E3287405	
DATE: 3/20/2019	
SEAL 	
DOCUMENT NOT CONSIDERED FINAL UNLESS ALL SIGNATURES COMPLETED	
PREPARED IN THE OFFICE OF: AE Accelerate Engineering, PLLC 875 Walnut Street, Suite 316 Cary, NC 27511 Tel: 919.263.5678 Fax: 919.263.5687 NC License No. P-1442	

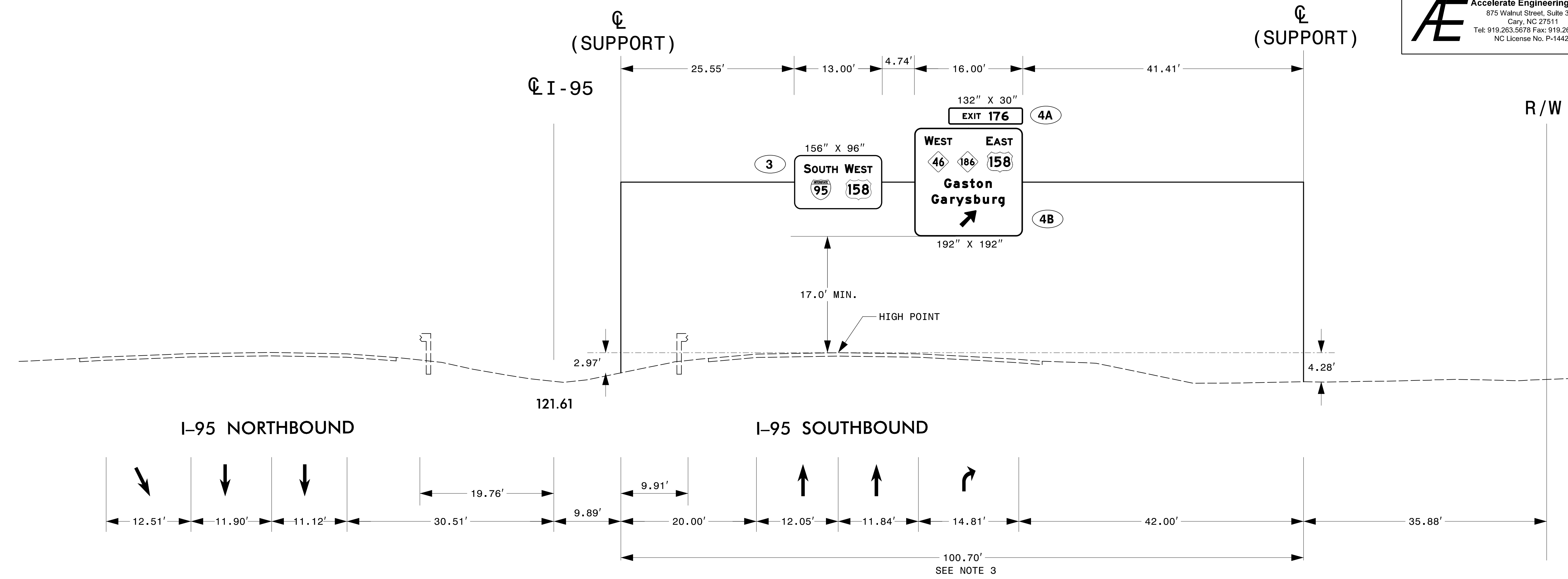

OVERHEAD SIGN ASSEMBLY 'B'
I-95 SB EXIT 176 THEORETICAL GORE

NOTES:

1. IF THE CONTRACTOR BIDS ALUMINUM SIGN STRUCTURE, EACH SHALL BE PROVIDED WITH AN APPROVED HIGHWAY TRUSS DAMPER DEVICE IN ACCORDANCE WITH AASHTO SPECIFICATIONS.
2. MOUNT SIGNS VERTICALLY CENTERED ON HORIZONTAL MEMBER OF STRUCTURE.
3. DIMENSIONS SHOWN ON THIS PLAN ARE ESTIMATED FOR PROJECT BID PURPOSES. FIELD VERIFICATION SHALL BE REQUIRED FOR ALL SUPPORT LOCATIONS, SPAN LENGTH AND FOOTING ELEVATIONS, PER THE LATEST NCDOT STANDARD SPECIFICATIONS FOR ROADS AND STRUCTURES. PROVIDE FIELD VERIFICATION TO THE SIGNING SECTION.
4. THE TOP OF THE FOOTING SHALL EXTEND AT LEAST 4 INCHES AND NOT MORE THAN 24 INCHES ABOVE THE HIGHEST POINT OF THE GROUND SURFACE AT THE FOOTING.
5. SIGN HANGERS AND ATTACHMENT HARDWARE SHALL BE PROVIDED AND INSTALLED ON THE ASSEMBLY TO ACCOMMODATE ALL SIGNS SHOWN IN THIS PLAN SHEET.
6. DESIGN AND CONSTRUCTION REQUIREMENTS FOR SIGN STRUCTURES SHALL ACCOMMODATE WIND VELOCITY OF 100 M.P.H.

OVERHEAD SIGN ASSEMBLY 'B'
I-95 EXIT 176

APPROVED: *Zhaolong Teng*
DATE: 8/13/2020

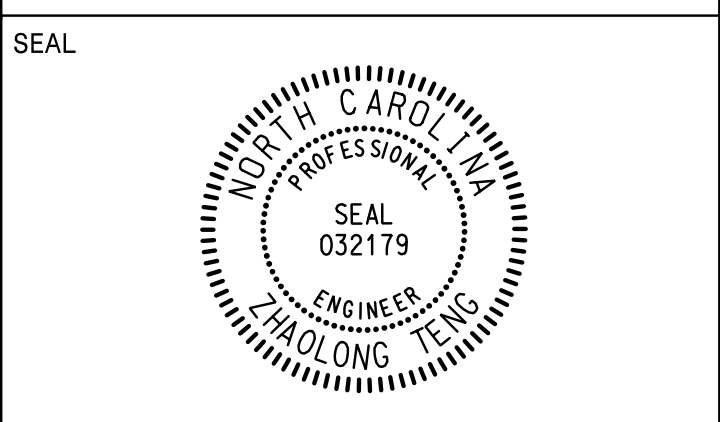

DOCUMENT NOT CONSIDERED FINAL UNLESS ALL SIGNATURES COMPLETED

PREPARED IN THE OFFICE OF:
AE Accelerate Engineering, PLLC
875 Walnut Street, Suite 316
Cary, NC 27511
Tel: 919.263.5678 Fax: 919.263.5687
NC License No. P-1442

401 QUANTITY REQ'D 17

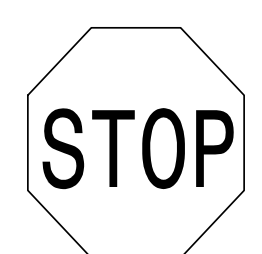

36 X 36
R1-1

ONE "U" POST PER SIGN
MOUNT BELOW SIGN 419
IN 9 INSTALLATIONS

402 QUANTITY REQ'D 1

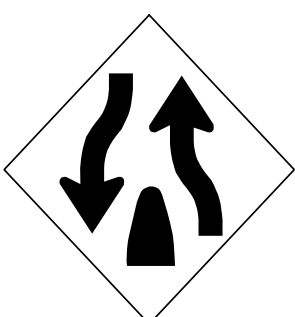

36 X 36
W6-2

ONE "U" POST PER SIGN

403 QUANTITY REQ'D 25

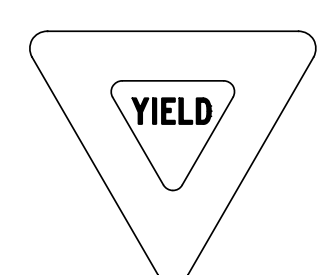

36 X 36 X 36
R1-2

ONE "U" POST PER SIGN

404 QUANTITY REQ'D 9

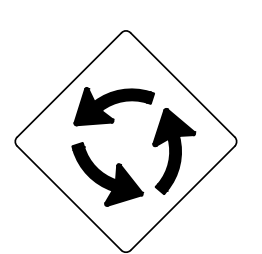

30 X 30
W2-6

ONE "U" POST PER SIGN

405 QUANTITY REQ'D 1

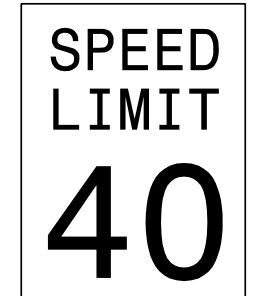

24 X 30
R2-1

ONE "U" POST PER SIGN

406 QUANTITY REQ'D 1

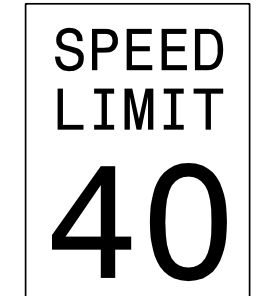

30 X 36
R2-1

ONE "U" POST PER SIGN

413 QUANTITY REQ'D 13

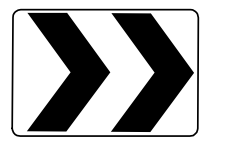

30 X 24
R6-4

ONE "U" POST PER SIGN

407 QUANTITY REQ'D 3



30 X 30
W14-2

ONE "U" POST PER SIGN

408 QUANTITY REQ'D 5



18 X 18
W13-1P

MOUNT BELOW SIGN 407 IN 1 INSTALLATION
MOUNT BELOW SIGN 431 IN 2 INSTALLATIONS
MOUNT BELOW SIGN 440 IN 1 INSTALLATION
MOUNT BELOW SIGN 441 IN 1 INSTALLATION

409 QUANTITY REQ'D 1



18 X 18
W13-1P

MOUNT BELOW SIGN 431
IN 1 INSTALLATION

410 QUANTITY REQ'D 11

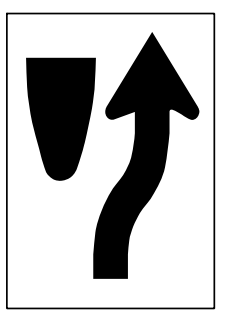

24 X 30
R4-7

ONE "U" POST PER SIGN

411 QUANTITY REQ'D 11

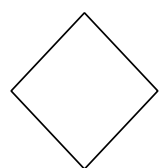

18 X 18
OM1-3

MOUNT BELOW SIGN 410
IN 11 INSTALLATIONS

412 QUANTITY REQ'D 2

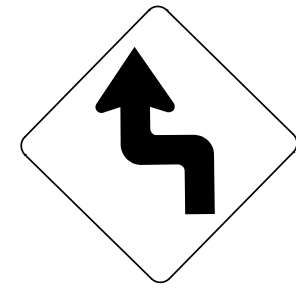

30 X 30
W1-3

ONE "U" POST PER SIGN

414 QUANTITY REQ'D 9

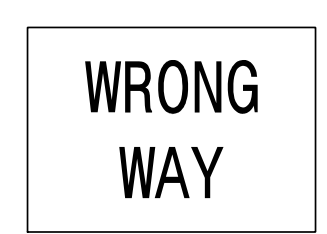

36 X 24
R5-1a

ONE "U" POST PER SIGN
MOUNT BEHIND SIGN 318 IN 1 INSTALLATION

415 QUANTITY REQ'D 2

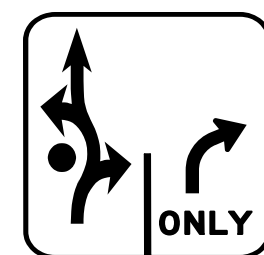

30 X 30
R3-8

ONE "U" POST PER SIGN

416 QUANTITY REQ'D 1



36 X 36
R3-7

ONE "U" POST PER SIGN

417 QUANTITY REQ'D 15



36 X 36
R3-4

ONE "U" POST PER SIGN

418 QUANTITY REQ'D 17

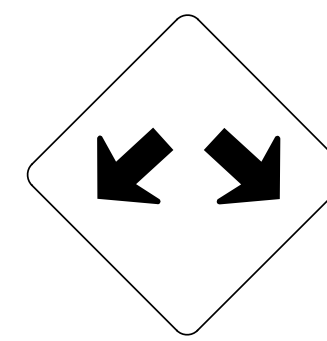

36 X 36
W12-1

ONE "U" POST PER SIGN

419 QUANTITY REQ'D 9



54 X 18
R6-1 (R)

TWO "U" POSTS PER SIGN

420 QUANTITY REQ'D 1



36 X 36
W3-5

ONE "U" POST PER SIGN

421 QUANTITY REQ'D 2

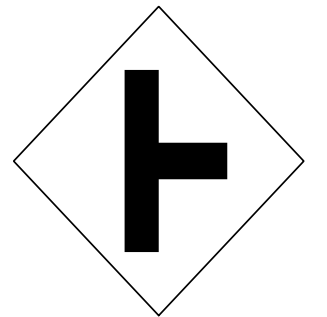

30 X 30
W2-2

ONE "U" POST PER SIGN

422 QUANTITY REQ'D 5

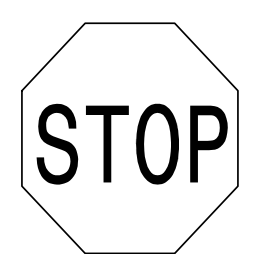

30 X 30
R1-1

ONE "U" POST PER SIGN

423 QUANTITY REQ'D 9

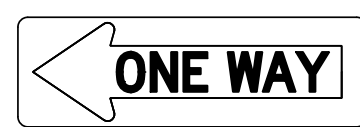

54 X 18
R6-1 (L)

TWO "U" POSTS PER SIGN

424 QUANTITY REQ'D 5



30 X 36
R2-1

ONE "U" POST PER SIGN

425 QUANTITY REQ'D 1



48 X 48
W3-5

TWO "U" POSTS PER SIGN

426 QUANTITY REQ'D 1



36 X 48
R2-1

TWO "U" POSTS PER SIGN

427 QUANTITY REQ'D 1



48 X 48
W3-5

TWO "U" POSTS PER SIGN

428 QUANTITY REQ'D 16

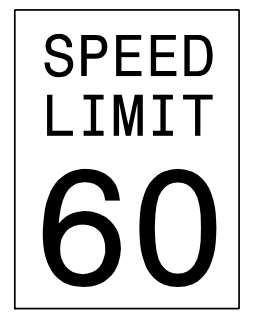

36 X 48
R2-1

TWO "U" POSTS PER SIGN

429 QUANTITY REQ'D 3



36 X 36
W1-10

ONE "U" POST PER SIGN

430 QUANTITY REQ'D 1

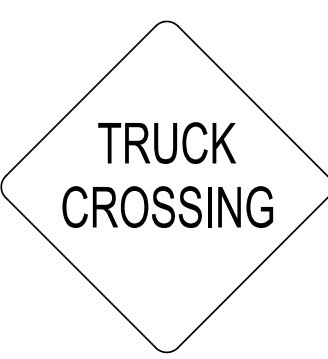

36 X 36
W8-6

ONE "U" POST PER SIGN

431 QUANTITY REQ'D 3



36 X 36
W14-2

ONE "U" POST PER SIGN

432 QUANTITY REQ'D 5

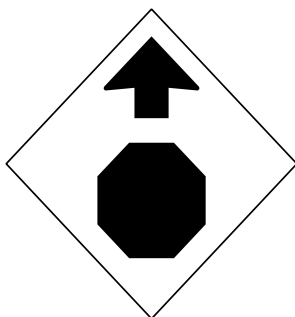

30 X 30
W3-1

ONE "U" POST PER SIGN

This plan supersedes the plan signed and sealed on 3/20/2019.

TYPE "E" SIGNS

Vertical text on the left margin: 11/11/2019 10:00 AM

APPROVED: *Shadong Teng*
DocuSigned by:
 8B6BA0D52524455
 DATE: 8/13/2020

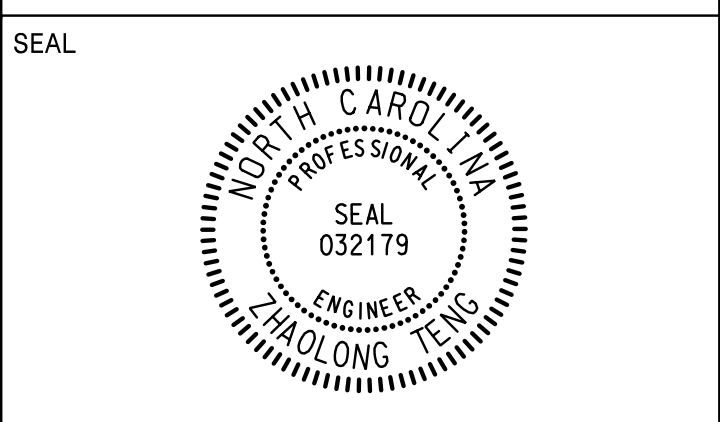

**DOCUMENT NOT CONSIDERED FINAL
UNLESS ALL SIGNATURES COMPLETED**

PREPARED IN THE OFFICE OF:
AE Accelerate Engineering, PLLC
 875 Walnut Street, Suite 316
 Cary, NC 27511
 Tel: 919.263.5678 Fax: 919.263.5687
 NC License No. P-1442

433 QUANTITY REQ'D 1

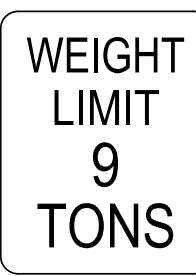

24 X 30
R12-1

ONE "U" POST PER SIGN

434 QUANTITY REQ'D 1

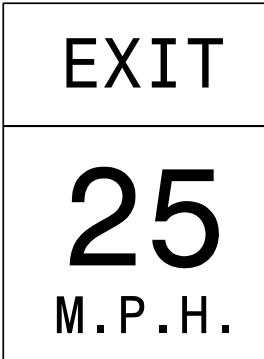

36 X 48
W13-2

TWO "U" POSTS PER SIGN

435 QUANTITY REQ'D 1

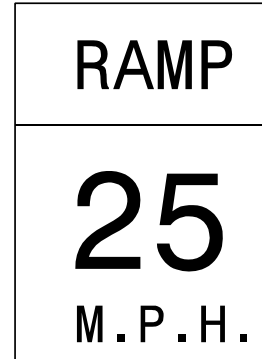

36 X 48
W13-3

TWO "U" POSTS PER SIGN

436 QUANTITY REQ'D 1

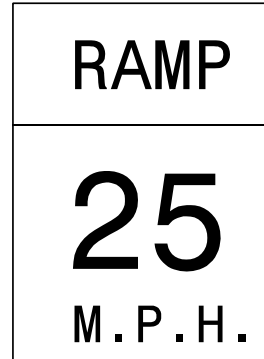

24 X 30
W13-3

ONE "U" POST PER SIGN

437 QUANTITY REQ'D 25

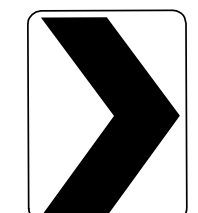

18 X 24
W1-8R
(RT SHOWN HERE)

ONE "U" POST PER SIGN
MOUNT BACK-TO-BACK
IN 4 INSTALLATIONS

438 QUANTITY REQ'D 2

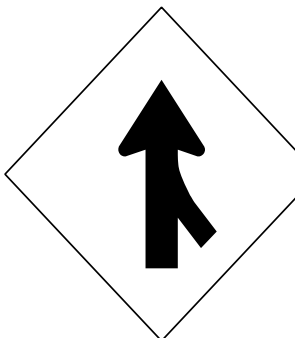

48 X 48
W4-1

TWO "U" POSTS PER SIGN

439 QUANTITY REQ'D 1

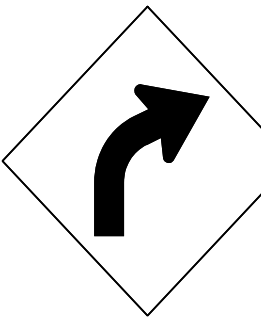

36 X 36
W1-2 (R)

ONE "U" POST PER SIGN

440 QUANTITY REQ'D 3



30 X 30
W1-2 (L)

ONE "U" POST PER SIGN

441 QUANTITY REQ'D 2

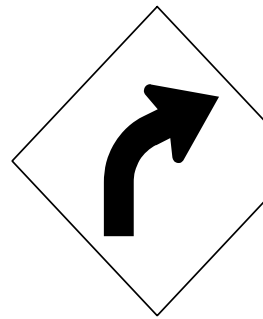

30 X 30
W1-2 (R)

ONE "U" POST PER SIGN

442 QUANTITY REQ'D 3



18 X 18
W13-1P

MOUNT BELOW SIGN 440 IN 2 INSTALLATIONS
MOUNT BELOW SIGN 441 IN 1 INSTALLATION

443 QUANTITY REQ'D 1



24 X 30
R2-1

ONE "U" POST PER SIGN

444 QUANTITY REQ'D 2

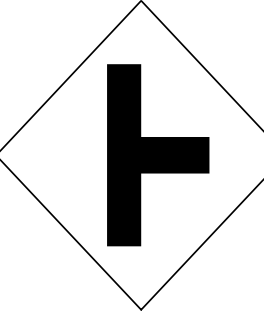

36 X 36
W2-2

ONE "U" POST PER SIGN

445 QUANTITY REQ'D 1



24 X 30
R12-2

ONE "U" POST PER SIGN

446 QUANTITY REQ'D 1

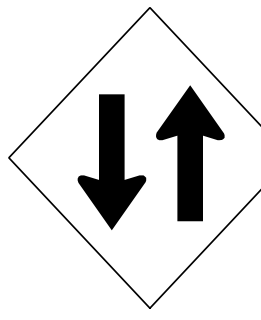

48 X 48
W6-3

TWO "U" POSTS PER SIGN

447 QUANTITY REQ'D 1

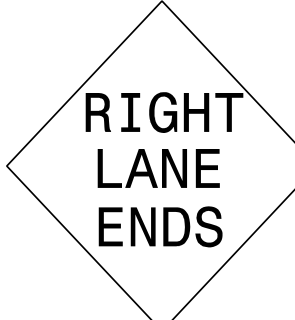

48 X 48
W9-1

TWO "U" POSTS PER SIGN

448 QUANTITY REQ'D 1

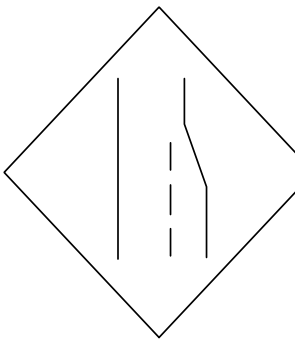

48 X 48
W4-2

TWO "U" POSTS PER SIGN

449 QUANTITY REQ'D 8

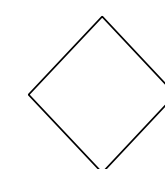

18 X 18
OM4-3

ONE 7' "U" POST (1.12 LB/FT) PER SIGN

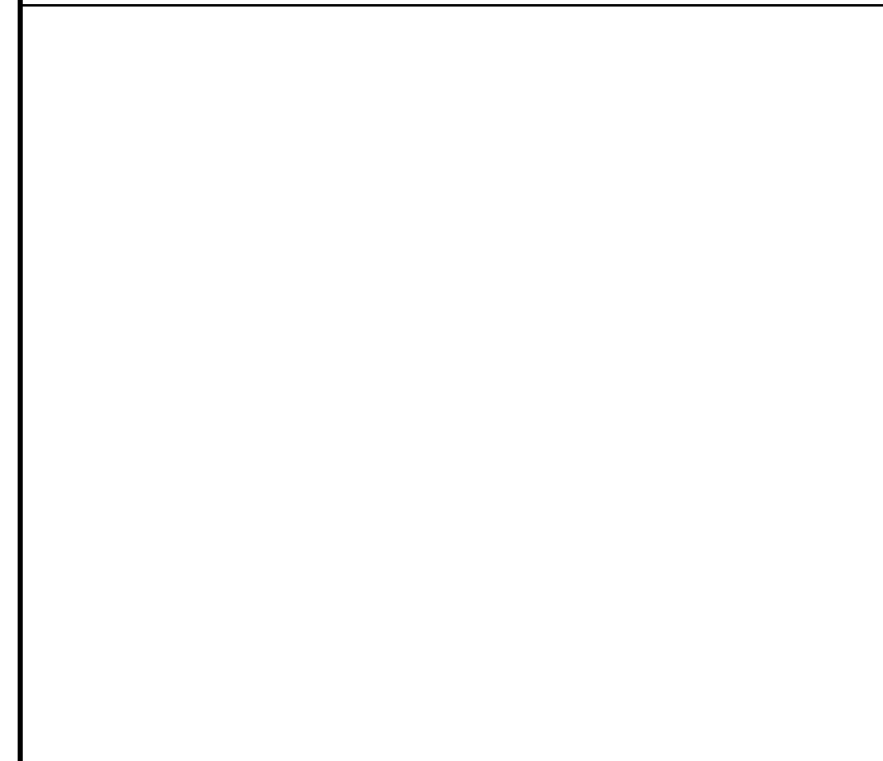

This plan supersedes the plan signed and sealed on 3/20/2019.

TYPE "E" SIGNS

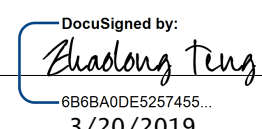
APPROVED: 
DocuSigned by:
Gao Long Teng
668BA0DE3257455
3/20/2019

DATE: _____

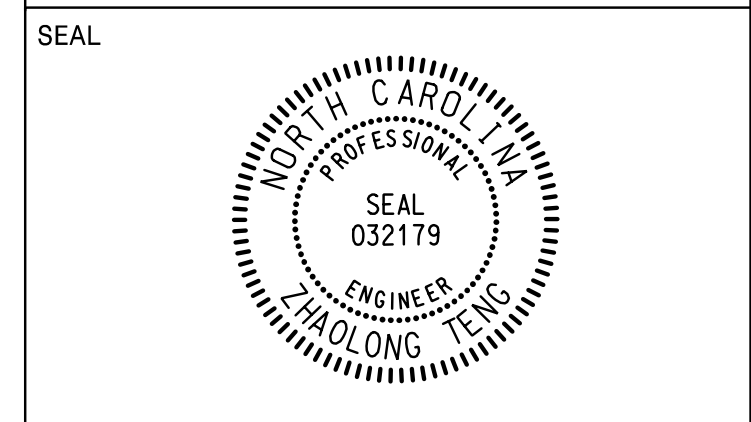

**DOCUMENT NOT CONSIDERED FINAL
UNLESS ALL SIGNATURES COMPLETED**

PREPARED IN THE OFFICE OF:

Accelerate Engineering, PLLC
 875 Walnut Street, Suite 316
 Cary, NC 27511
 Tel: 919.263.5678 Fax: 919.263.5687
 NC License No. P-1442

SIGN NUMBER: 101A, 102A TYPE: B	BACKG COLOR: Green COPY COLOR: White	DESIGN BY: G TENG	CHECKED BY: E THOMAS	Sep 08, 2018
QUANTITY: 1		PROJECT ID: R-2582A	LOCATION: SEE SIGN-5 AND SIGN-6	DIV: 1 & 4

SIGN WIDTH: 11'-0"
 HEIGHT: 2'-6"
 TOTAL AREA: 27.5 Sq.-Ft.

BORDER TYPE: FLUSH
 RECESS: 0"
 WIDTH: 2"
 RADII: 3"

NO. Z BARS: 2
 LENGTH: 124.0

MAT'L: 0.125" (3.2 mm) ALUMINUM

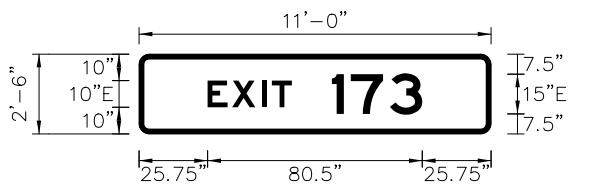

USE NOTES:
 1. Legend and border(except those that are colored black) shall be direct applied Grade C sheeting.
 2. Background shall be Grade C reflective sheeting.

LETTER POSITIONS

Letter spacings are to start of next letter

	E	X	I	T	Series/Size Text Length			
	25.7	9.2	11.1	3.8	7.5	74.6	E 2000	31.6
	1	7	3				E 2000	33.9
	72.4	7.1	14.7	12.2	25.7			

FILENAME: R-2582A_Sgn_GuideSIGN NORTH CAROLINA D.O.T. SIGN DETAIL

SIGN NUMBER: 101B, 107B TYPE: A	BACKG COLOR: Green COPY COLOR: White	DESIGN BY: G TENG	CHECKED BY: E THOMAS	Sep 09, 2018
QUANTITY: 1		PROJECT ID: R-2582A	LOCATION: SEE SIGN-5 AND SIGN-6	DIV: 1 & 4

SIGN WIDTH: 21'-2"
 HEIGHT: 16'-2"
 TOTAL AREA: 342.2 Sq.-Ft.

BORDER TYPE: FLUSH
 RECESS: 0"
 WIDTH: 2"
 RADII: 12"

NO. Z BARS: 6
 LENGTH: 246.0

MAT'L: 0.125" (3.2 mm) ALUMINUM

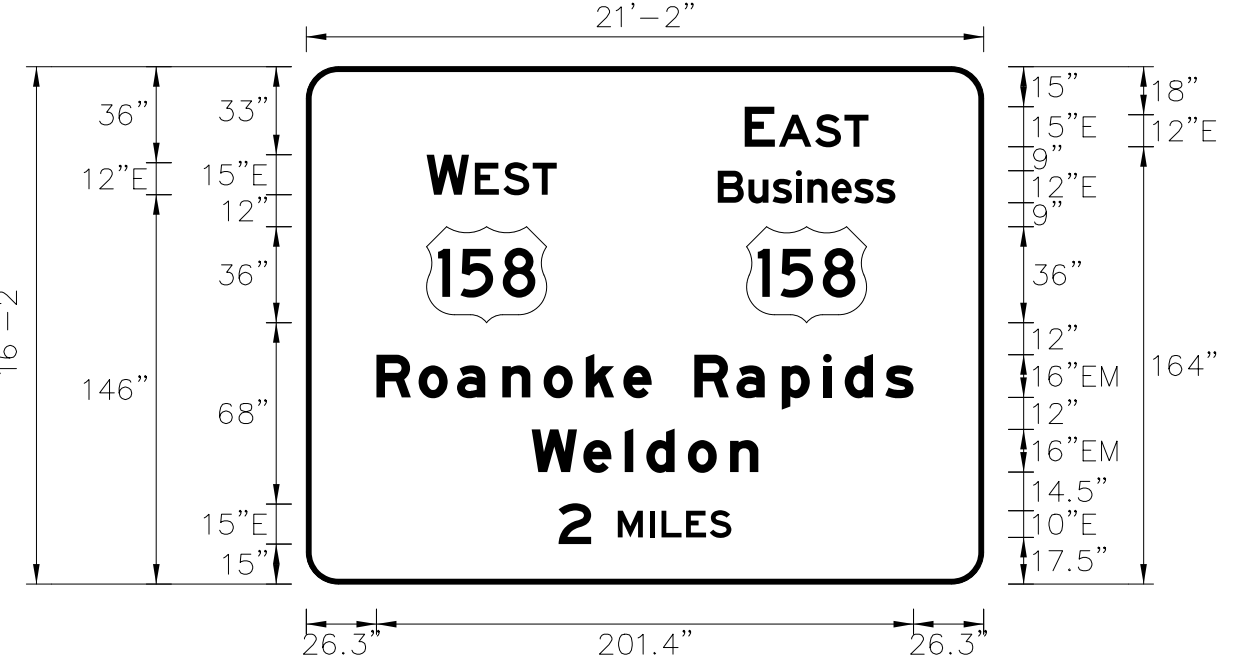

USE NOTES:
 1. Legend and border(except those that are colored black) shall be direct applied Grade C sheeting.
 2. Background shall be Grade C reflective sheeting.
 3. Shields; A, B, and C type arrows shall be on 0.032" (0.8mm) aluminum with Grade C reflective sheeting and demountable.

LETTER POSITIONS

Letter spacings are to start of next letter

	E	A	S	T	Series/Size Text Length													
	16.4	11.3	1.5	13.6	11	9	43.2	E 2000	46.4									
	45.1	15.9	2.2	10.7	11	9	160.1	E 2000	48.8									
	154.3	11.5	9	8.8	4.3	9.1	8.4	8.2	7.3	33.1	E 2000	66.6						
	26.3	15.8	14.4	17	15.5	15.8	14.1	10.6	16	15.8	17	15.5	8.2	15.2	10.6	26.3	EM 2000	201.4
	84.5	19.4	15.5	8.2	15.5	15.8	10.6	84.5									EM 2000	85
	2	M	I	L	E	S											E 2000	64.8
	94.6	12.1	10	12	4.4	9.2	8.9	8.1	94.6									

FILENAME: R-2582A_Sgn_GuideSIGN NORTH CAROLINA D.O.T. SIGN DETAIL

SIGN NUMBER: 102B TYPE: A	BACKG COLOR: Green COPY COLOR: White	DESIGN BY: G TENG	CHECKED BY: E THOMAS	Sep 08, 2018
QUANTITY: 1		PROJECT ID: R-2582A	LOCATION: SEE SIGN-5	DIV: 4

SIGN WIDTH: 20'-0"
 HEIGHT: 16'-2"
 TOTAL AREA: 323.3 Sq.-Ft.

BORDER TYPE: FLUSH
 RECESS: 0"
 WIDTH: 2"
 RADII: 12"

NO. Z BARS: 6
 LENGTH: 232.0

MAT'L: 0.125" (3.2 mm) ALUMINUM

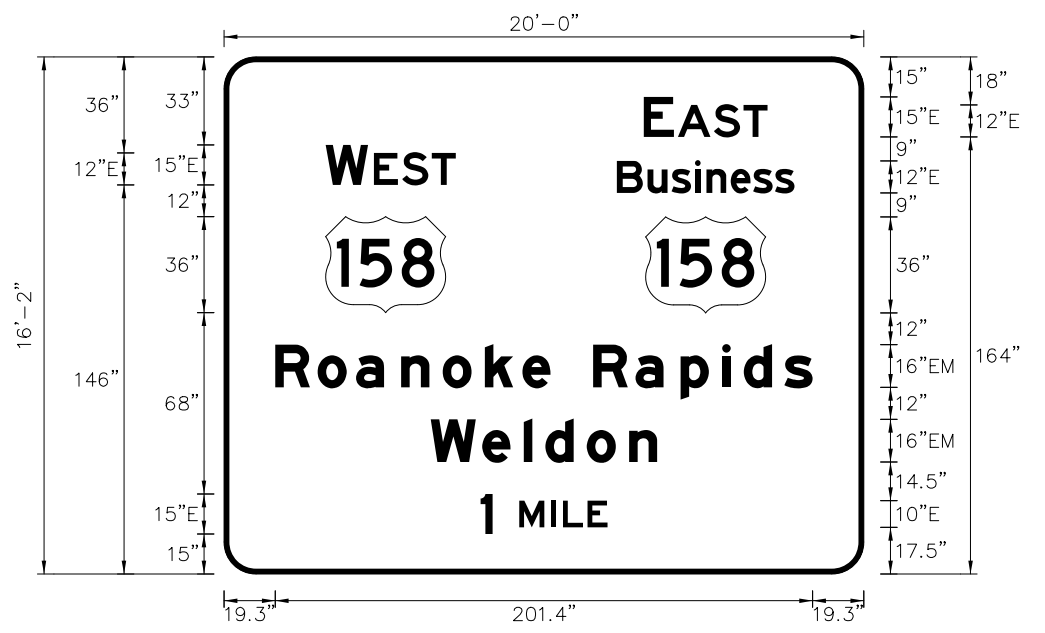

USE NOTES:
 1. Legend and border(except those that are colored black) shall be direct applied Grade C sheeting.
 2. Background shall be Grade C reflective sheeting.
 3. Shields; A, B, and C type arrows shall be on 0.032" (0.8mm) aluminum with Grade C reflective sheeting and demountable.

LETTER POSITIONS

Letter spacings are to start of next letter

	E	A	S	T	Series/Size Text Length													
	157.5	11.3	1.5	13.6	11	9	36.2	E 2000	46.4									
	38.1	15.9	2.2	10.7	11	9	153.1	E 2000	48.8									
	147.3	11.5	9	8.8	4.3	9.1	8.4	8.2	7.3	26.1	E 2000	66.6						
	19.3	15.8	14.4	17	15.5	15.8	14.1	10.6	16	15.8	17	15.5	8.2	15.2	10.6	19.3	EM 2000	201.4
	77.5	19.4	15.5	8.2	15.5	15.8	10.6	77.5									EM 2000	85
	1	M	I	L	E	S											E 2000	47.6
	96.2	4.5	10	12	4.4	9.2	7.5	96.2										

FILENAME: R-2582A_Sgn_GuideSIGN NORTH CAROLINA D.O.T. SIGN DETAIL

SIGN NUMBER: 103, 104 TYPE: A	BACKG COLOR: Green COPY COLOR: White	DESIGN BY: G TENG	CHECKED BY: E THOMAS	Sep 08, 2018
QUANTITY: 1		PROJECT ID: R-2582A	LOCATION: SEE SIGN-2 AND SIGN-7	DIV: 4

SIGN WIDTH: 8'-0"
 HEIGHT: 5'-0"
 TOTAL AREA: 40.0 Sq.-Ft.

BORDER TYPE: FLUSH
 RECESS: 0"
 WIDTH: 1.5"
 RADII: 6"

NO. Z BARS: 2
 LENGTH: 88.0

MAT'L: 0.125" (3.2 mm) ALUMINUM

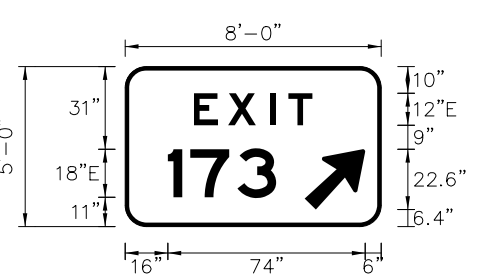

USE NOTES:
 1. Legend and border(except those that are colored black) shall be direct applied Grade C sheeting.
 2. Background shall be Grade C reflective sheeting.
 3. Shields; A, B, and C type arrows shall be on 0.032" (0.8mm) aluminum with Grade C reflective sheeting and demountable.

LETTER POSITIONS

Letter spacings are to start of next letter

	E	X	I	T	Series/Size Text Length			
	25.8	12.8	15.8	6.8	9	25.8	E 2000	44.4
	16	8.5	17.6	14.6	39.3		E 2000	40.7

FILENAME: R-2582A_Sgn_GuideSIGN NORTH CAROLINA D.O.T. SIGN DETAIL

**GROUND MOUNTED
SIGN DESIGNS**

01
02
03
04
05
06
07
08
09
10
11
12
13
14
15
16
17
18
19
20
21
22
23
24
25
26
27
28
29
30
31
32
33
34
35
36
37
38
39
40
41
42
43
44
45
46
47
48
49
50
51
52
53
54
55
56
57
58
59
60
61
62
63
64
65
66
67
68
69
70
71
72
73
74
75
76
77
78
79
80
81
82
83
84
85
86
87
88
89
90
91
92
93
94
95
96
97
98
99
100

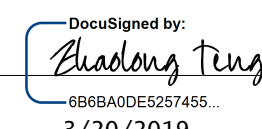
APPROVED: 
 DATE: 3/20/2019

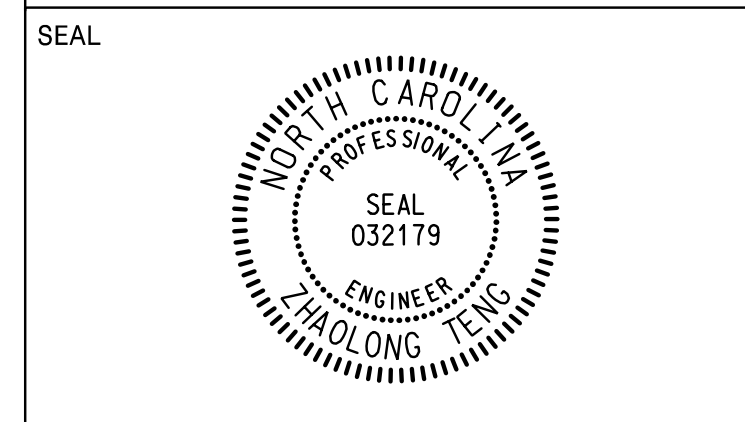

**DOCUMENT NOT CONSIDERED FINAL
UNLESS ALL SIGNATURES COMPLETED**

PREPARED IN THE OFFICE OF:
Accelerate Engineering, PLLC
 875 Walnut Street, Suite 316
 Cary, NC 27511
 Tel: 919.263.5678 Fax: 919.263.5687
 NC License No. P-1442

SIGN NUMBER: 105B TYPE: A QUANTITY: 1 SIGN WIDTH: 20'-0" HEIGHT: 17'-6" TOTAL AREA: 350.0 Sq.Ft. BORDER TYPE: FLUSH RECESS: 0" WIDTH: 2" RADIUS: 12" NO. Z BARS: 6 LENGTH: 232.0	BACKG COLOR: Green COPY COLOR: White SYMBOL X Y WID HT M1_4 38.1 114 45 36 M1_4 158.1 114 45 36 AR_Type A 105.1 16.3 24 37.8 MAT'L: 0.125" (3.2 mm) ALUMINUM	DESIGN BY: G TENG PROJECT ID: R-2582A CHECKED BY: E THOMAS LOCATION: SEE SIGN-5 Sep 08, 2018 DIV: 1
---	--	--

USE NOTES:
 1. Legend and border(except those that are colored black) shall be direct applied Grade C sheeting.
 2. Background shall be Grade C reflective sheeting.
 3. Shields; A, B, and C type arrows shall be on 0.032" (0.8mm) aluminum with Grade C reflective sheeting and demountable.

LETTER POSITIONS

Letter spacings are to start of next letter											Series/Size	Text Length					
E	A	S	T								E 2000	46.4					
157.5	11.3	1.5	13.6	11	9	36.2					E 2000	48.8					
W	E	S	T								E 2000	66.6					
38.1	15.9	2.2	10.7	11	9	153.1					E 2000	201.4					
B	u	s	i	n	e	s	s				EM 2000	85					
147.3	11.5	9	8.8	4.3	9.1	8.4	8.2	7.3	26.1		EM 2000	89.1					
R	o	a	n	o	k	e	R	a	p	i	d	s					
19.3	15.8	14.4	17	15.5	15.8	14.1	10.6	16	15.8	17	15.5	8.2	15.2	10.6	19.3		
W	e	l	d	o	n												
77.5	19.4	15.5	8.2	15.5	15.8	10.6	77.5										

FILENAME: R-2582A_Sgn_GuideSIGN NORTH CAROLINA D.O.T. SIGN DETAIL

SIGN NUMBER: 106B TYPE: A QUANTITY: 1 SIGN WIDTH: 20'-0" HEIGHT: 16'-2" TOTAL AREA: 323.3 Sq.Ft. BORDER TYPE: FLUSH RECESS: 0" WIDTH: 2" RADIUS: 12" NO. Z BARS: 6 LENGTH: 232.0	BACKG COLOR: Green COPY COLOR: White SYMBOL X Y WID HT M1_4 38.1 98 45 36 M1_4 158.1 98 45 36 MAT'L: 0.125" (3.2 mm) ALUMINUM	DESIGN BY: G TENG PROJECT ID: R-2582A CHECKED BY: E THOMAS LOCATION: SEE SIGN-6 Sep 08, 2018 DIV: 1
---	--	--

USE NOTES:
 1. Legend and border(except those that are colored black) shall be direct applied Grade C sheeting.
 2. Background shall be Grade C reflective sheeting.
 3. Shields; A, B, and C type arrows shall be on 0.032" (0.8mm) aluminum with Grade C reflective sheeting and demountable.

LETTER POSITIONS

Letter spacings are to start of next letter											Series/Size	Text Length					
E	A	S	T								E 2000	46.4					
157.4	11.3	1.5	13.6	11	9	36.2					E 2000	48.8					
W	E	S	T								E 2000	66.6					
38.1	15.9	2.2	10.7	11	9	153.1					E 2000	201.4					
B	u	s	i	n	e	s	s				EM 2000	85					
147.3	11.5	9	8.8	4.3	9.1	8.4	8.2	7.3	26.1		EM 2000	89.1					
R	o	a	n	o	k	e	R	a	p	i	d	s					
19.3	15.8	14.4	17	15.5	15.8	14.1	10.6	16	15.8	17	15.5	8.2	15.2	10.6	19.3		
W	e	l	d	o	n												
77.5	19.4	15.5	8.2	15.5	15.8	10.6	77.5										
1	1/4	M	I	L	E	S											
75.5	4.5	10	22	10	12	4.4	9.2	8.9	8.1	75.5							

FILENAME: R-2582A_Sgn_GuideSIGN NORTH CAROLINA D.O.T. SIGN DETAIL

SIGN NUMBER: 108A, 109A, 110A TYPE: B QUANTITY: 1 SIGN WIDTH: 11'-0" HEIGHT: 2'-6" TOTAL AREA: 27.5 Sq.Ft. BORDER TYPE: FLUSH RECESS: 0" WIDTH: 2" RADIUS: 3" NO. Z BARS: 2 LENGTH: 124.0	BACKG COLOR: Green COPY COLOR: White SYMBOL X Y WID HT MAT'L: 0.125" (3.2 mm) ALUMINUM	DESIGN BY: G TENG PROJECT ID: R-2582A CHECKED BY: E THOMAS LOCATION: SEE SIGN-6 Sep 08, 2018 DIV: 1
--	---	--

USE NOTES:
 1. Legend and border(except those that are colored black) shall be direct applied Grade C sheeting.
 2. Background shall be Grade C reflective sheeting.

LETTER POSITIONS

Letter spacings are to start of next letter						Series/Size	Text Length
E	X	I	T			E 2000	31.6
25.5	9.2	11.1	3.8	7.5	74.9	E 2000	34.4
1	7	6					
72.1	7.1	15.1	12.2	25.5			

FILENAME: R-2582A_Sgn_GuideSIGN NORTH CAROLINA D.O.T. SIGN DETAIL

SIGN NUMBER: 108B, 112B TYPE: A QUANTITY: 1 SIGN WIDTH: 15'-4" HEIGHT: 14'-6" TOTAL AREA: 222.3 Sq.Ft. BORDER TYPE: FLUSH RECESS: 0" WIDTH: 2" RADIUS: 12" NO. Z BARS: 5 LENGTH: 176.0	BACKG COLOR: Green COPY COLOR: White SYMBOL X Y WID HT M1-5-2-36-15C 22.4 97 36 36 M1-5-3-36-12D 72.4 97 36 36 M1_4 123 96.5 45 36 MAT'L: 0.125" (3.2 mm) ALUMINUM	DESIGN BY: G TENG PROJECT ID: R-2582A CHECKED BY: E THOMAS LOCATION: SEE SIGN-6 Sep 09, 2018 DIV: 1
---	--	--

USE NOTES:
 1. Legend and border(except those that are colored black) shall be direct applied Grade C sheeting.
 2. Background shall be Grade C reflective sheeting.
 3. Shields; A, B, and C type arrows shall be on 0.032" (0.8mm) aluminum with Grade C reflective sheeting and demountable.

LETTER POSITIONS

Letter spacings are to start of next letter											Series/Size	Text Length
W	E	S	T								E 2000	48.8
16	15.9	2.2	10.7	11	9	119.2					E 2000	46.4
E	A	S	T								EM 2000	83.8
121.6	11.3	1.5	13.6	11	9	16					EM 2000	128.8
G	o	s	t	o	n						E 2000	47.6
50.1	16.3	15.2	13.9	12	15.8	10.6	50.1					
G	a	r	y	s	b	u	r	g				
27.6	16.3	17	10.1	16.5	15.5	15.5	17	10.4	10.6	27.6		
1	1	M	I	L	E	S						
68.2	4.5	10	12	4.4	9.2	7.5	68.2					

FILENAME: R-2582A_Sgn_GuideSIGN NORTH CAROLINA D.O.T. SIGN DETAIL

**GROUND MOUNTED
SIGN DESIGNS**

01
02
03
04
05
06
07
08
09
10
11
12
13
14
15
16
17
18
19
20
21
22
23
24
25
26
27
28
29
30
31
32
33
34
35
36
37
38
39
40
41
42
43
44
45
46
47
48
49
50
51
52
53
54
55
56
57
58
59
60
61
62
63
64
65
66
67
68
69
70
71
72
73
74
75
76
77
78
79
80
81
82
83
84
85
86
87
88
89
90
91
92
93
94
95
96
97
98
99
100

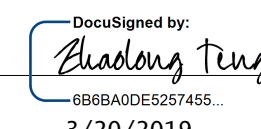
APPROVED: 
 DATE: 3/20/2019

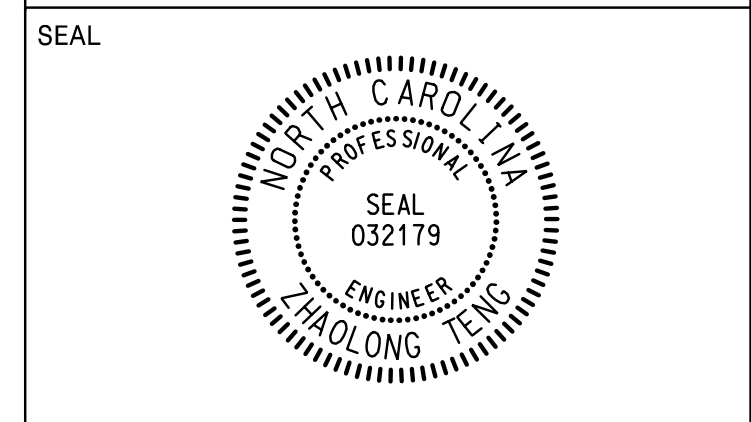

**DOCUMENT NOT CONSIDERED FINAL
UNLESS ALL SIGNATURES COMPLETED**

PREPARED IN THE OFFICE OF:
Accelerate Engineering, PLLC
 875 Walnut Street, Suite 316
 Cary, NC 27511
 Tel: 919.263.5678 Fax: 919.263.5687
 NC License No. P-1442

SIGN NUMBER: 115, 116 TYPE: A QUANTITY: 1 SIGN WIDTH: 6'-0" HEIGHT: 5'-0" TOTAL AREA: 30.0 Sq.Ft. BORDER TYPE: FLUSH RECESS: 0" WIDTH: 1.5" RADII: 6" NO. Z BARS: 2 LENGTH: 64.0	BACKG COLOR: Green COPY COLOR: White SYMBOL X Y WID HT AR_Type A 26.4 11.8 15.5 24.3	DESIGN BY: G TENG PROJECT ID: R-2582A CHECKED BY: E THOMAS LOCATION: -L- STA. 201+98 & STA. 217+28 DIV: 1 Sep 08, 2018
---	---	---

USE NOTES:
 1. Legend and border(except those that are colored black) shall be direct applied Grade C sheeting.
 2. Background shall be Grade C reflective sheeting.
 3. Shields: A, B, and C type arrows shall be on 0.032" (0.8mm) aluminum with Grade C reflective sheeting and decoutable.

Spacing Factor is 1 unless specified otherwise

LETTER POSITIONS

Letter spacings are to start of next letter										Series/Size
										Text Length
	E	X	I	T						E 2000
	17.5	10.6	13.2	5.6	7.5	17.5				37

FILENAME: R-2582A_Sgn_GuideSIGN NORTH CAROLINA D.O.T. SIGN DETAIL

SIGN NUMBER: 119 TYPE: A QUANTITY: 1 SIGN WIDTH: 13'-0" HEIGHT: 7'-6" TOTAL AREA: 97.5 Sq.Ft. BORDER TYPE: FLUSH RECESS: 0" WIDTH: 2" RADII: 12" NO. Z BARS: 3 LENGTH: 148.0	BACKG COLOR: Blue COPY COLOR: White SYMBOL X Y WID HT	DESIGN BY: G TENG PROJECT ID: R-2582A CHECKED BY: E THOMAS LOCATION: SEE SIGN-5 DIV: 4 Oct 25, 2018
---	---	--

USE NOTES:
 1. Legend and border(except those that are colored black) shall be direct applied Grade C sheeting.
 2. Background shall be Grade C reflective sheeting.

Spacing Factor is 1 unless specified otherwise

LETTER POSITIONS

Letter spacings are to start of next letter															Series/Size
															Text Length
	H	O	S	P	I	T	A	L							D 2000
	41.7	10.8	10.3	10.2	10	3.7	8.2	12	7.4	41.7					72.6
	E	X	I	T											D 2000
	42.6	7.2	8.5	3.1	6.2	15	6.6	13.9	10.2	42.6					70.7
	T	o	u	r	i	s	t								E 2000
	13.9	8.5	7.8	8	5.7	3.1	6.5	4.6	10	4	7.4	4.6	6.4	10	128.3

FILENAME: R-2582A_Sgn_GuideSIGN NORTH CAROLINA D.O.T. SIGN DETAIL

SIGN NUMBER: 301 TYPE: D QUANTITY: 1 SIGN WIDTH: 5'-6" HEIGHT: 2'-6" TOTAL AREA: 13.8 Sq.Ft. BORDER TYPE: FLUSH RECESS: 0" WIDTH: 0.75" RADII: 3" NO. Z BARS: LENGTH:	BACKG COLOR: Green COPY COLOR: White SYMBOL X Y WID HT AR_FTSHOOK 7.4 16.9 9.9 10.8 AR_Type D 49.6 4.8 6 9	DESIGN BY: G Teng PROJECT ID: R-2582A CHECKED BY: E THOMAS LOCATION: I-95 -RPA- STA. 15+00 DIV: 1 Sep 08, 2018
--	--	---

USE NOTES:
 1. Legend and border(except those that are colored black) shall be direct applied Grade C sheeting.
 2. Background shall be Grade C reflective sheeting.

Spacing Factor is 1 unless specified otherwise

LETTER POSITIONS

Letter spacings are to start of next letter										Series/Size
										Text Length
	G	a	s	t	o	n				D 2000
	23.3	5	4.2	3.1	2.8	4.6	3.5	19.4		23.2
	G	a	r	y	s	b	u	r	g	D 2000
	7.4	5	4.6	2.5	4.9	3.6	4.5	4.7	2.8	36.1

FILENAME: R-2582A_Sgn_GuideSIGN NORTH CAROLINA D.O.T. SIGN DETAIL

SIGN NUMBER: 302 TYPE: D QUANTITY: 1 SIGN WIDTH: 6'-6" HEIGHT: 2'-6" TOTAL AREA: 16.3 Sq.Ft. BORDER TYPE: FLUSH RECESS: 0" WIDTH: 0.75" RADII: 3" NO. Z BARS: LENGTH:	BACKG COLOR: Green COPY COLOR: White SYMBOL X Y WID HT AR_Type D 8.2 17.8 6 9 AR_Type D 55.1 4.8 6 9	DESIGN BY: G Teng PROJECT ID: R-2582A CHECKED BY: E THOMAS LOCATION: -L- STA. 29+50 DIV: 1 Sep 08, 2018
--	--	--

USE NOTES:
 1. Legend and border(except those that are colored black) shall be direct applied Grade C sheeting.
 2. Background shall be Grade C reflective sheeting.

Spacing Factor is 1 unless specified otherwise

LETTER POSITIONS

Letter spacings are to start of next letter												Series/Size
												Text Length
	R	o	c	k	y							D 2000
	20.2	4.7	4.4	4.3	4.1	4.5	6	5.8	4.6	4.7	4.1	49.6
	E	m	p	o	r	i	a					D 2000
	20.2	4.6	7.1	4.3	4.6	3	1.9	3.4	28.9			28.9

FILENAME: R-2582A_Sgn_GuideSIGN NORTH CAROLINA D.O.T. SIGN DETAIL

01
02
03
04
05
06
07
08
09
10
11
12
13
14
15
16
17
18
19
20
21
22
23
24
25
26
27
28
29
30
31
32
33
34
35
36
37
38
39
40
41
42
43
44
45
46
47
48
49
50
51
52
53
54
55
56
57
58
59
60
61
62
63
64
65
66
67
68
69
70
71
72
73
74
75
76
77
78
79
80
81
82
83
84
85
86
87
88
89
90
91
92
93
94
95
96
97
98
99
100

**GROUND MOUNTED
SIGN DESIGNS**

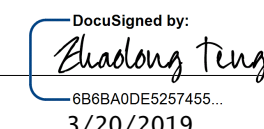
APPROVED: 
 DATE: 3/20/2019

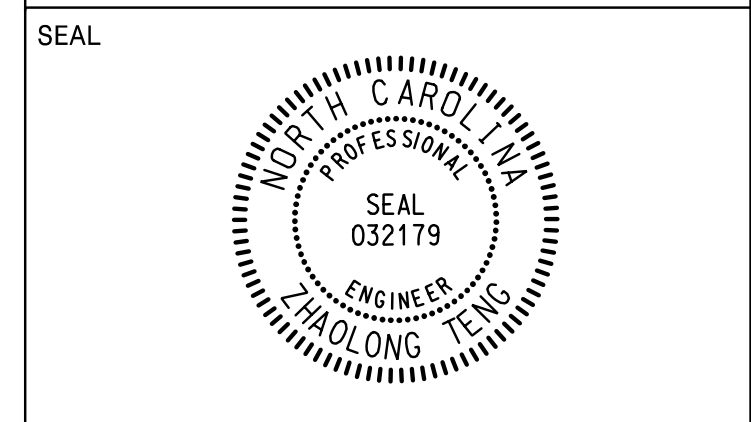

**DOCUMENT NOT CONSIDERED FINAL
UNLESS ALL SIGNATURES COMPLETED**

PREPARED IN THE OFFICE OF:
Accelerate Engineering, PLLC
 875 Walnut Street, Suite 316
 Cary, NC 27511
 Tel: 919.263.5678 Fax: 919.263.5687
 NC License No. P-1442

SIGN NUMBER: 303 TYPE: D QUANTITY: 1 SIGN WIDTH: 6'-6" HEIGHT: 2'-6" TOTAL AREA: 16.3 Sq.Ft. BORDER TYPE: FLUSH RECESS: 0" WIDTH: 0.75" RADII: 3" NO. Z BARS: _____ LENGTH: _____	BACKG COLOR: Green COPY COLOR: White <table border="1"> <tr><th>SYMBOL</th><th>X</th><th>Y</th><th>WID</th><th>HT</th></tr> <tr><td>AR_Type D</td><td>21.4</td><td>17.8</td><td>6</td><td>9</td></tr> <tr><td>AR_FISHHOOK</td><td>6.2</td><td>2.4</td><td>9.9</td><td>10.8</td></tr> </table> MAT'L: 0.125" (3.2 mm) ALUMINUM	SYMBOL	X	Y	WID	HT	AR_Type D	21.4	17.8	6	9	AR_FISHHOOK	6.2	2.4	9.9	10.8	DESIGN BY: G TENG PROJECT ID: R-2582A CHECKED BY: E THOMAS LOCATION: -L- STA. 21+30 Sep 08, 2018 DIV: 1
SYMBOL	X	Y	WID	HT													
AR_Type D	21.4	17.8	6	9													
AR_FISHHOOK	6.2	2.4	9.9	10.8													

USE NOTES:
 1. Legend and border(except those that are colored black) shall be direct applied Grade C sheeting.
 2. Background shall be Grade C reflective sheeting.

Spacing Factor is 1 unless specified otherwise

LETTER POSITIONS

Letter spacings are to start of next letter													Series/Size
													Text Length
G	a	s	t	o	n								D 2000
33.4	5	4.2	3.1	2.8	4.6	3.5	21.4						23.2
R	o	c	k	y	M	o	u	n	t				D 2000
22.1	4.7	4.4	4.3	4.1	4.5	6	5.8	4.6	4.7	4.1	2.4	6.2	49.6

FILENAME: R-2582A_Sgn_GuideSIGN NORTH CAROLINA D.O.T. SIGN DETAIL

SIGN NUMBER: 304 TYPE: D QUANTITY: 1 SIGN WIDTH: 5'-6" HEIGHT: 2'-6" TOTAL AREA: 13.8 Sq.Ft. BORDER TYPE: FLUSH RECESS: 0" WIDTH: 0.75" RADII: 3" NO. Z BARS: _____ LENGTH: _____	BACKG COLOR: Green COPY COLOR: White <table border="1"> <tr><th>SYMBOL</th><th>X</th><th>Y</th><th>WID</th><th>HT</th></tr> <tr><td>AR_FISHHOOK</td><td>7</td><td>16.9</td><td>9.9</td><td>10.8</td></tr> <tr><td>AR_Type D</td><td>43.1</td><td>4.8</td><td>6</td><td>9</td></tr> </table> MAT'L: 0.125" (3.2 mm) ALUMINUM	SYMBOL	X	Y	WID	HT	AR_FISHHOOK	7	16.9	9.9	10.8	AR_Type D	43.1	4.8	6	9	DESIGN BY: G TENG PROJECT ID: R-2582A CHECKED BY: E THOMAS LOCATION: I-95 -RPC- STA. 12+25 Sep 08, 2018 DIV: 1
SYMBOL	X	Y	WID	HT													
AR_FISHHOOK	7	16.9	9.9	10.8													
AR_Type D	43.1	4.8	6	9													

USE NOTES:
 1. Legend and border(except those that are colored black) shall be direct applied Grade C sheeting.
 2. Background shall be Grade C reflective sheeting.

Spacing Factor is 1 unless specified otherwise

LETTER POSITIONS

Letter spacings are to start of next letter													Series/Size
													Text Length
G	a	r	y	s	b	u	r	g					D 2000
22.9	5	4.6	2.5	4.9	3.6	4.5	4.7	2.8	3.6	7			36.1
G	o	s	t	o	n								D 2000
13.9	5	4.2	3.1	2.8	4.6	3.5	28.9						23.2

FILENAME: R-2582A_Sgn_GuideSIGN NORTH CAROLINA D.O.T. SIGN DETAIL

SIGN NUMBER: 305 TYPE: D QUANTITY: 1 SIGN WIDTH: 6'-6" HEIGHT: 2'-6" TOTAL AREA: 16.3 Sq.Ft. BORDER TYPE: FLUSH RECESS: 0" WIDTH: 0.75" RADII: 3" NO. Z BARS: _____ LENGTH: _____	BACKG COLOR: Green COPY COLOR: White <table border="1"> <tr><th>SYMBOL</th><th>X</th><th>Y</th><th>WID</th><th>HT</th></tr> <tr><td>AR_Type D</td><td>18.5</td><td>17.8</td><td>6</td><td>9</td></tr> <tr><td>AR_Type D</td><td>62.3</td><td>4.8</td><td>6</td><td>9</td></tr> </table> MAT'L: 0.125" (3.2 mm) ALUMINUM	SYMBOL	X	Y	WID	HT	AR_Type D	18.5	17.8	6	9	AR_Type D	62.3	4.8	6	9	DESIGN BY: G TENG PROJECT ID: R-2582A CHECKED BY: E THOMAS LOCATION: -L- STA. 17+00 Sep 08, 2018 DIV: 1
SYMBOL	X	Y	WID	HT													
AR_Type D	18.5	17.8	6	9													
AR_Type D	62.3	4.8	6	9													

USE NOTES:
 1. Legend and border(except those that are colored black) shall be direct applied Grade C sheeting.
 2. Background shall be Grade C reflective sheeting.

Spacing Factor is 1 unless specified otherwise

LETTER POSITIONS

Letter spacings are to start of next letter													Series/Size
													Text Length
E	m	p	o	r	i	a							D 2000
30.5	4.6	7.1	4.3	4.6	3	1.9	3.4	18.5					28.9
R	o	c	k	y	M	o	u	n	t				D 2000
6.7	4.7	4.4	4.3	4.1	4.5	6	5.8	4.6	4.7	4.1	2.4	21.7	49.6

FILENAME: R-2582A_Sgn_GuideSIGN NORTH CAROLINA D.O.T. SIGN DETAIL

SIGN NUMBER: 306 TYPE: D QUANTITY: 1 SIGN WIDTH: 5'-0" HEIGHT: 2'-6" TOTAL AREA: 12.5 Sq.Ft. BORDER TYPE: FLUSH RECESS: 0" WIDTH: 0.75" RADII: 3" NO. Z BARS: _____ LENGTH: _____	BACKG COLOR: Green COPY COLOR: White <table border="1"> <tr><th>SYMBOL</th><th>X</th><th>Y</th><th>WID</th><th>HT</th></tr> <tr><td>AR_Type D</td><td>6</td><td>17.8</td><td>6</td><td>9</td></tr> <tr><td>AR_FISHHOOK</td><td>6</td><td>2.4</td><td>9.9</td><td>10.8</td></tr> </table> MAT'L: 0.125" (3.2 mm) ALUMINUM	SYMBOL	X	Y	WID	HT	AR_Type D	6	17.8	6	9	AR_FISHHOOK	6	2.4	9.9	10.8	DESIGN BY: G TENG PROJECT ID: R-2582A CHECKED BY: E THOMAS LOCATION: -L- STA. 25+00 Sep 08, 2018 DIV: 1
SYMBOL	X	Y	WID	HT													
AR_Type D	6	17.8	6	9													
AR_FISHHOOK	6	2.4	9.9	10.8													

USE NOTES:
 1. Legend and border(except those that are colored black) shall be direct applied Grade C sheeting.
 2. Background shall be Grade C reflective sheeting.

Spacing Factor is 1 unless specified otherwise

LETTER POSITIONS

Letter spacings are to start of next letter													Series/Size
													Text Length
G	a	r	y	s	b	u	r	g					D 2000
17.9	5	4.6	2.5	4.9	3.6	4.5	4.7	2.8	3.6	6			36.1
E	m	p	o	r	i	a							D 2000
21.9	4.6	7.1	4.3	4.6	3	1.9	3.4	9.2					28.9

FILENAME: R-2582A_Sgn_GuideSIGN NORTH CAROLINA D.O.T. SIGN DETAIL

**GROUND MOUNTED
SIGN DESIGNS**

01
02
03
04
05
06
07
08
09
10
11
12
13
14
15
16
17
18
19
20
21
22
23
24
25
26
27
28
29
30
31
32
33
34
35
36
37
38
39
40
41
42
43
44
45
46
47
48
49
50
51
52
53
54
55
56
57
58
59
60
61
62
63
64
65
66
67
68
69
70
71
72
73
74
75
76
77
78
79
80
81
82
83
84
85
86
87
88
89
90
91
92
93
94
95
96
97
98
99
100

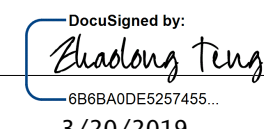
APPROVED: 
 DATE: 3/20/2019

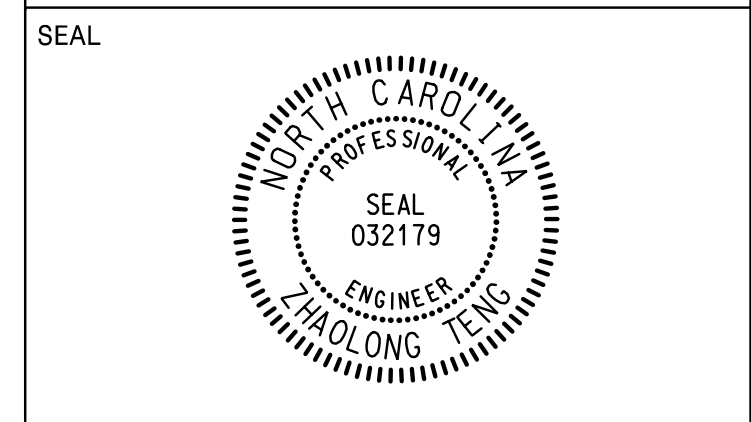

**DOCUMENT NOT CONSIDERED FINAL
UNLESS ALL SIGNATURES COMPLETED**

PREPARED IN THE OFFICE OF:
Accelerate Engineering, PLLC
 875 Walnut Street, Suite 316
 Cary, NC 27511
 Tel: 919.263.5678 Fax: 919.263.5687
 NC License No. P-1442

SIGN NUMBER: 307 TYPE: D QUANTITY: 1 SIGN WIDTH: 5'-0" HEIGHT: 2'-6" TOTAL AREA: 12.5 Sq.Ft. BORDER TYPE: FLUSH RECESS: 0" WIDTH: 0.75" RADII: 3" NO. Z BARS: LENGTH:	BACKG COLOR: Green COPY COLOR: White SYMBOL X Y WID HT AR_Type D 6 17.8 6 9 AR_Type D 45 4.8 6 9	DESIGN BY: G TENG PROJECT ID: R-2582A CHECKED BY: E THOMAS LOCATION: -Y9- STA. 18+10 Sep 08, 2018 DIV: 1
--	--	---

USE NOTES:
 1. Legend and border(except those that are colored black) shall be direct applied Grade C sheeting.
 2. Background shall be Grade C reflective sheeting.

Spacing Factor is 1 unless specified otherwise

LETTER POSITIONS

Letter spacings are to start of next letter											Series/Size
											Text Length
G	a	r	y	s	b	u	r	g			D 2000
17.9	5	4.6	2.5	4.9	3.6	4.5	4.7	2.8	3.6	6	36.1
J	a	c	k	s	o	n					D 2000
9.8	4.9	4.3	4.3	4.2	3.4	4.6	3.5	2.1			29.2

FILENAME: R-2582A_Sgn_GuideSIGN NORTH CAROLINA D.O.T. SIGN DETAIL

SIGN NUMBER: 308,311 TYPE: D QUANTITY: 1 SIGN WIDTH: 5'-6" HEIGHT: 2'-6" TOTAL AREA: 13.8 Sq.Ft. BORDER TYPE: FLUSH RECESS: 0" WIDTH: 0.75" RADII: 3" NO. Z BARS: LENGTH:	BACKG COLOR: Green COPY COLOR: White SYMBOL X Y WID HT AR_FISHOOK 7.4 16.9 9.9 10.8 AR_Type D 49.6 4.8 6 9	DESIGN BY: G TENG PROJECT ID: R-2582A CHECKED BY: E THOMAS LOCATION: -Y9LPD- STA. 18+50 -Y9RPA- STA. 31+00 Sep 08, 2018 DIV: 1
--	--	--

USE NOTES:
 1. Legend and border(except those that are colored black) shall be direct applied Grade C sheeting.
 2. Background shall be Grade C reflective sheeting.

Spacing Factor is 1 unless specified otherwise

LETTER POSITIONS

Letter spacings are to start of next letter											Series/Size
											Text Length
W	e	l	d	o	n						D 2000
23.3	5.9	4.4	1.9	4.6	4.6	3.5	17.8				24.9
G	a	r	y	s	b	u	r	g			D 2000
7.4	5	4.6	2.5	4.9	3.6	4.5	4.7	2.8	3.6	22.4	36.1

FILENAME: R-2582A_Sgn_GuideSIGN NORTH CAROLINA D.O.T. SIGN DETAIL

SIGN NUMBER: 309 TYPE: D QUANTITY: 1 SIGN WIDTH: 5'-0" HEIGHT: 2'-6" TOTAL AREA: 12.5 Sq.Ft. BORDER TYPE: FLUSH RECESS: 0" WIDTH: 0.75" RADII: 3" NO. Z BARS: LENGTH:	BACKG COLOR: Green COPY COLOR: White SYMBOL X Y WID HT AR_Type D 11.5 17.8 6 9 AR_FISHOOK 7.4 2.4 9.9 10.8	DESIGN BY: G TENG PROJECT ID: R-2582A CHECKED BY: E THOMAS LOCATION: -Y9- STA. 22+00 Sep 08, 2018 DIV: 1
--	--	---

USE NOTES:
 1. Legend and border(except those that are colored black) shall be direct applied Grade C sheeting.
 2. Background shall be Grade C reflective sheeting.

Spacing Factor is 1 unless specified otherwise

LETTER POSITIONS

Letter spacings are to start of next letter											Series/Size
											Text Length
W	e	l	d	o	n						D 2000
23.6	5.9	4.4	1.9	4.6	4.6	3.5	11.5				24.9
J	a	c	k	s	o	n					D 2000
23.3	4.9	4.3	4.3	4.2	3.4	4.6	3.5	7.4			29.2

FILENAME: R-2582A_Sgn_GuideSIGN NORTH CAROLINA D.O.T. SIGN DETAIL

SIGN NUMBER: 310 TYPE: D QUANTITY: 1 SIGN WIDTH: 5'-0" HEIGHT: 2'-6" TOTAL AREA: 12.5 Sq.Ft. BORDER TYPE: FLUSH RECESS: 0" WIDTH: 0.75" RADII: 3" NO. Z BARS: LENGTH:	BACKG COLOR: Green COPY COLOR: White SYMBOL X Y WID HT AR_Type D 6 17.8 6 9 AR_Type D 40.1 4.8 6 9	DESIGN BY: G TENG PROJECT ID: R-2582A CHECKED BY: E THOMAS LOCATION: -Y9- STA. 28+50 Sep 08, 2018 DIV: 1
--	--	---

USE NOTES:
 1. Legend and border(except those that are colored black) shall be direct applied Grade C sheeting.
 2. Background shall be Grade C reflective sheeting.

Spacing Factor is 1 unless specified otherwise

LETTER POSITIONS

Letter spacings are to start of next letter											Series/Size
											Text Length
G	a	r	y	s	b	u	r	g			D 2000
17.9	5	4.6	2.5	4.9	3.6	4.5	4.7	2.8	3.6	6	36.1
G	a	s	t	o	n						D 2000
10.9	5	4.2	3.1	2.8	4.6	3.5	25.9				23.2

FILENAME: R-2582A_Sgn_GuideSIGN NORTH CAROLINA D.O.T. SIGN DETAIL

01
02
03
04
05
06
07
08
09
10
11
12
13
14
15
16
17
18
19
20
21
22
23
24
25
26
27
28
29
30
31
32
33
34
35
36
37
38
39
40
41
42
43
44
45
46
47
48
49
50
51
52
53
54
55
56
57
58
59
60
61
62
63
64
65
66
67
68
69
70
71
72
73
74
75
76
77
78
79
80
81
82
83
84
85
86
87
88
89
90
91
92
93
94
95
96
97
98
99
100

**GROUND MOUNTED
SIGN DESIGNS**

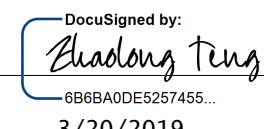
APPROVED: 
 DATE: 3/20/2019

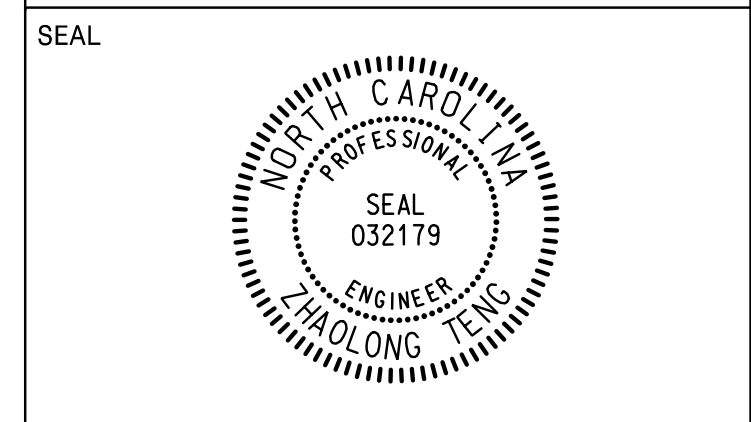

DOCUMENT NOT CONSIDERED FINAL UNLESS ALL SIGNATURES COMPLETED

PREPARED IN THE OFFICE OF:
Accelerate Engineering, PLLC
 875 Walnut Street, Suite 316
 Cary, NC 27511
 Tel: 919.263.5678 Fax: 919.263.5687
 NC License No. P-1442

SIGN NUMBER: 312 TYPE: D QUANTITY: 1 SIGN WIDTH: 4'-6" HEIGHT: 2'-6" TOTAL AREA: 11.3 Sq.Ft. BORDER TYPE: FLUSH RECESS: 0" WIDTH: 0.75" RADII: 3" NO. Z BARS: LENGTH:	BACKG COLOR: Green COPY COLOR: White SYMBOL X Y WID HT AR_Type D 9.5 17.8 6 9 AR_FISHOOK 7.4 2.4 9.9 10.8	DESIGN BY: G TENG PROJECT ID: R-2582A CHECKED BY: E THOMAS LOCATION: -Y9- STA. 33+00 Sep 08, 2018 DIV: 1
---	---	---

USE NOTES:
 1. Legend and border(except those that are colored black) shall be direct applied Grade C sheeting.
 2. Background shall be Grade C reflective sheeting.

Spacing Factor is 1 unless specified otherwise

LETTER POSITIONS

Letter spacings are to start of next letter

Series/Size	Text	Length
D 2000	W e l d o n	24.9
D 2000	G a s t o n	23.2

FILENAME: R-2582A_Sgn_GuideSIGN NORTH CAROLINA D.O.T. SIGN DETAIL

SIGN NUMBER: 313 TYPE: D QUANTITY: 1 SIGN WIDTH: 7'-6" HEIGHT: 2'-6" TOTAL AREA: 18.8 Sq.Ft. BORDER TYPE: FLUSH RECESS: 0" WIDTH: 0.75" RADII: 3" NO. Z BARS: LENGTH:	BACKG COLOR: Green COPY COLOR: White SYMBOL X Y WID HT	DESIGN BY: G TENG PROJECT ID: R-2582A CHECKED BY: E THOMAS LOCATION: -Y9- STA. 12+00 Sep 13, 2018 DIV: 1
---	--	---

USE NOTES:
 1. Legend and border(except those that are colored black) shall be direct applied Grade C sheeting.
 2. Background shall be Grade C reflective sheeting.

Spacing Factor is 1 unless specified otherwise

LETTER POSITIONS

Letter spacings are to start of next letter

Series/Size	Text	Length
D 2000	R o a n o k e R a p i d s 9	75.6
D 2000	E n f i e l d	23.6
D 2000	2 1	6.8

FILENAME: R-2582A_Sgn_GuideSIGN NORTH CAROLINA D.O.T. SIGN DETAIL

SIGN NUMBER: 314 TYPE: D QUANTITY: 1 SIGN WIDTH: 4'-6" HEIGHT: 1'-6" TOTAL AREA: 6.8 Sq.Ft. BORDER TYPE: FLUSH RECESS: 0" WIDTH: 0.75" RADII: 3" NO. Z BARS: LENGTH:	BACKG COLOR: Green COPY COLOR: White SYMBOL X Y WID HT AR_Type D 6 5.4 6 9	DESIGN BY: G TENG PROJECT ID: R-2582A CHECKED BY: E THOMAS LOCATION: SEE SIGN-20 Sep 08, 2018 DIV: 1
--	---	---

USE NOTES:
 1. Legend and border(except those that are colored black) shall be direct applied Grade C sheeting.
 2. Background shall be Grade C reflective sheeting.

Spacing Factor is 1 unless specified otherwise

LETTER POSITIONS

Letter spacings are to start of next letter

Series/Size	Text	Length
D 2000	E m p o r i a	28.9

FILENAME: R-2582A_Sgn_GuideSIGN NORTH CAROLINA D.O.T. SIGN DETAIL

SIGN NUMBER: 315 TYPE: D QUANTITY: 1 SIGN WIDTH: 4'-6" HEIGHT: 1'-6" TOTAL AREA: 6.8 Sq.Ft. BORDER TYPE: FLUSH RECESS: 0" WIDTH: 0.75" RADII: 3" NO. Z BARS: LENGTH:	BACKG COLOR: Green COPY COLOR: White SYMBOL X Y WID HT AR_Type D 38.9 5.4 6 9	DESIGN BY: G TENG PROJECT ID: R-2582A CHECKED BY: E THOMAS LOCATION: SEE SIGN-20 Sep 08, 2018 DIV: 1
--	--	---

USE NOTES:
 1. Legend and border(except those that are colored black) shall be direct applied Grade C sheeting.
 2. Background shall be Grade C reflective sheeting.

Spacing Factor is 1 unless specified otherwise

LETTER POSITIONS

Letter spacings are to start of next letter

Series/Size	Text	Length
D 2000	W e l d o n	24.9

FILENAME: R-2582A_Sgn_GuideSIGN NORTH CAROLINA D.O.T. SIGN DETAIL

GROUND MOUNTED SIGN DESIGNS

09
08
07
06
05
04
03
02
01
00
99
98
97
96
95
94
93
92
91
90
89
88
87
86
85
84
83
82
81
80
79
78
77
76
75
74
73
72
71
70
69
68
67
66
65
64
63
62
61
60
59
58
57
56
55
54
53
52
51
50
49
48
47
46
45
44
43
42
41
40
39
38
37
36
35
34
33
32
31
30
29
28
27
26
25
24
23
22
21
20
19
18
17
16
15
14
13
12
11
10
09
08
07
06
05
04
03
02
01
00
99
98
97
96
95
94
93
92
91
90
89
88
87
86
85
84
83
82
81
80
79
78
77
76
75
74
73
72
71
70
69
68
67
66
65
64
63
62
61
60
59
58
57
56
55
54
53
52
51
50
49
48
47
46
45
44
43
42
41
40
39
38
37
36
35
34
33
32
31
30
29
28
27
26
25
24
23
22
21
20
19
18
17
16
15
14
13
12
11
10
09
08
07
06
05
04
03
02
01
00
99
98
97
96
95
94
93
92
91
90
89
88
87
86
85
84
83
82
81
80
79
78
77
76
75
74
73
72
71
70
69
68
67
66
65
64
63
62
61
60
59
58
57
56
55
54
53
52
51
50
49
48
47
46
45
44
43
42
41
40
39
38
37
36
35
34
33
32
31
30
29
28
27
26
25
24
23
22
21
20
19
18
17
16
15
14
13
12
11
10
09
08
07
06
05
04
03
02
01
00
99
98
97
96
95
94
93
92
91
90
89
88
87
86
85
84
83
82
81
80
79
78
77
76
75
74
73
72
71
70
69
68
67
66
65
64
63
62
61
60
59
58
57
56
55
54
53
52
51
50
49
48
47
46
45
44
43
42
41
40
39
38
37
36
35
34
33
32
31
30
29
28
27
26
25
24
23
22
21
20
19
18
17
16
15
14
13
12
11
10
09
08
07
06
05
04
03
02
01
00
99
98
97
96
95
94
93
92
91
90
89
88
87
86
85
84
83
82
81
80
79
78
77
76
75
74
73
72
71
70
69
68
67
66
65
64
63
62
61
60
59
58
57
56
55
54
53
52
51
50
49
48
47
46
45
44
43
42
41
40
39
38
37
36
35
34
33
32
31
30
29
28
27
26
25
24
23
22
21
20
19
18
17
16
15
14
13
12
11
10
09
08
07
06
05
04
03
02
01
00
99
98
97
96
95
94
93
92
91
90
89
88
87
86
85
84
83
82
81
80
79
78
77
76
75
74
73
72
71
70
69
68
67
66
65
64
63
62
61
60
59
58
57
56
55
54
53
52
51
50
49
48
47
46
45
44
43
42
41
40
39
38
37
36
35
34
33
32
31
30
29
28
27
26
25
24
23
22
21
20
19
18
17
16
15
14
13
12
11
10
09
08
07
06
05
04
03
02
01
00
99
98
97
96
95
94
93
92
91
90
89
88
87
86
85
84
83
82
81
80
79
78
77
76
75
74
73
72
71
70
69
68
67
66
65
64
63
62
61
60
59
58
57
56
55
54
53
52
51
50
49
48
47
46
45
44
43
42
41
40
39
38
37
36
35
34
33
32
31
30
29
28
27
26
25
24
23
22
21
20
19
18
17
16
15
14
13
12
11
10
09
08
07
06
05
04
03
02
01
00
99
98
97
96
95
94
93
92
91
90
89
88
87
86
85
84
83
82
81
80
79
78
77
76
75
74
73
72
71
70
69
68
67
66
65
64
63
62
61
60
59
58
57
56
55
54
53
52
51
50
49
48
47
46
45
44
43
42
41
40
39
38
37
36
35
34
33
32
31
30
29
28
27
26
25
24
23
22
21
20
19
18
17
16
15
14
13
12
11
10
09
08
07
06
05
04
03
02
01
00
99
98
97
96
95
94
93
92
91
90
89
88
87
86
85
84
83
82
81
80
79
78
77
76
75
74
73
72
71
70
69
68
67
66
65
64
63
62
61
60
59
58
57
56
55
54
53
52
51
50
49
48
47
46
45
44
43
42
41
40
39
38
37
36
35
34
33
32
31
30
29
28
27
26
25
24
23
22
21
20
19
18
17
16
15
14
13
12
11
10
09
08
07
06
05
04
03
02
01
00
99
98
97
96
95
94
93
92
91
90
89
88
87
86
85
84
83
82
81
80
79
78
77
76
75
74
73
72
71
70
69
68
67
66
65
64
63
62
61
60
59
58
57
56
55
54
53
52
51
50
49
48
47
46
45
44
43
42
41
40
39
38
37
36
35
34
33
32
31
30
29
28
27
26
25
24
23
22
21
20
19
18
17
16
15
14
13
12
11
10
09
08
07
06
05
04
03
02
01
00
99
98
97
96
95
94
93
92
91
90
89
88
87
86
85
84
83
82
81
80
79
78
77
76
75
74
73
72
71
70
69
68
67
66
65
64
63
62
61
60
59
58
57
56
55
54
53
52
51
50
49
48
47
46
45
44
43
42
41
40
39
38
37
36
35
34
33
32
31
30
29
28
27
26
25
24
23
22
21
20
19
18
17
16
15
14
13
12
11
10
09
08
07
06
05
04
03
02
01
00
99
98
97
96
95
94
93
92
91
90
89
88
87
86
85
84
83
82
81
80
79
78
77
76
75
74
73
72
71
70
69
68
67
66
65
64
63
62
61
60
59
58
57
56
55
54
53
52
51
50
49
48
47
46
45
44
43
42
41
40
39
38
37
36
35
34
33
32
31
30
29
28
27
26
25
24
23
22
21
20
19
18
17
16
15
14
13
12
11
10
09
08
07
06
05
04
03
02
01
00
99
98
97
96
95
94
93
92
91
90
89
88
87
86
85
84
83
82
81
80
79
78
77
76
75
74
73
72
71
70
69
68
67
66
65
64
63
62
61
60
59
58
57
56
55
54
53
52
51
50
49
48
47
46
45
44
43
42
41
40
39
38
37
36
35
34
33
32
31
30
29
28
27
26
25
24
23
22
21
20
19
18
17
16
15
14
13
12
11
10
09
08
07
06
05
04
03
02
01
00
99
98
97
96
95
94
93
92
91
90
89
88
87
86
85
84
83
82
81
80
79
78
77
76
75
74
73
72
71
70
69
68
67
66
65
64
63
62
61
60
59
58
57
56
55
54
53
52
51
50
49
48
47
46
45
44
43
42
41
40
39
38
37
36
35
34
33
32
31
30
29
28
27
26
25
24
23
22
21
20
19
18
17
16
15
14
13
12
11
10
09
08
07
06
05
04
03
02
01
00
99
98
97
96
95
94
93
92
91
90
89
88
87
86
85
84
83
82
81
80
79
78
77
76
75
74
73
72
71
70
69
68
67
66
65
64
63
62
61
60
59
58
57
56
55
54
53
52
51
50
49
48
47
46
45
44
43
42
41
40
39
38
37
36
35
34
33
32
31
30
29
28
27
26
25
24
23
22
21
20
19
18
17
16
15
14
13
12
11
10
09
08
07
06
05
04
03
02
01
00
99
98
97
96
95
94
93
92
91
90
89
88
87
86
85
84
83
82
81
80
79
78
77
76
75
74
73
72
71
70
69
68
67
66
65
64
63
62
61
60
59
58
57
56
55
54
53
52
51
50
49
48
47
46
45
44
43
42
41
40
39
38
37
36
35
34
33
32
31
30
29
28
27
26
25
24
23
22
21
20
19
18
17
16
15
14
13
12
11
10
09
08
07
06
05
04
03
02
01
00
99
98
97
96
95
94
93
92
91
90
89
88
87
86
85
84
83
82
81
80
79
78
77
76
75
74
73
72
71
70
69
68
67
66
65
64
63
62
61
60
59
58
57
56
55
54
53
52
51
50
49
48
47
46
45
44
43
42
41
40
39
38
37
36
35
34
33
32
31
30
29
28
27
26
25
24
23
22
21
20
19
18
17
16
15
14
13
12
11
10
09
08
07
06
05
04
03
02
01
00
99
98
97
96
95
94
93
92
91
90
89
88
87
86
85
84
83
82
81
80
79
78
77
76
75
74
73
72
71
70
69
68
67
66
65
64
63
62
61
60
59
58
57
56
55
54
53
52
51
50
49
48
47
46
45
44
43
42
41
40
39
38
37
36
35
34
33
32
31
30
29
28
27
26
25
24
23
22
21
20
19
18
17
16
15
14
13
12
11
10
09
08
07
06
05
04
03
02
01
00
99
98
97
96
95
94
93
92
91
90
89
88
87
86
85
84
83
82
81
80
79
78
77
76
75
74
73
72
71
70
69
68
67
66
65
64
63
62
61
60
59
58
57
56
55
54
53
52
51
50
49
48
47
46
45
44
43
42
41
40
39
38
37
36
35
34
33
32
31
30
29
28
27
26
25
24
23
22
21
20
19
18
17
16
15
14
13
12
11
10
09
08
07
06
05
04
03
02
01
00
99
98
97
96
95
94
93
92
91
90
89
88
87
86
85
84
83
82
81
80
79
78
77
76
75
74
73
72
71
70
69
68
67
66
65
64
63
62
61
60
59
58
57
56
55
54
53
52
51
50
49
48
47
46
45
44
43
42
41
40
39
38
37
36
35
34
33
32
31
30
29
28
27
26
25
24
23
22
21
20
19
18
17
16
15
14
13
12
11
10
09
08
07
06
05
04
03
02
01
00
99
98
97
96
95
94
93
92
91
90
89
88
87
86
85
84
83
82
81
80
79
78
77
76
75
74
73
72
71
70
69
68
67
66
65
64
63
62
61
60
59
58
57
56
55
54
53
52
51
50
49
48
47
46
45
44
43
42
41
40
39
38
37
36
35
34
33
32
31
30
29
28
27
26
25
24
23
22
21
20
19
18
17
16
15
14
13
12
11
10
09
08
07
06
05
04
03
02
01
00
99
98
97
96
95
94
93
92
91
90
89
88
87
86
85
84
83
82
81
80
79
78
77
76
75
74
73
72
71
70
69
68
67
66
65
64
63
62
61
60
59
58
57
56
55
54
53
52
51
50
49
48
47
46
45
44
43
42
41
40
39
38
37
36
35
34
33
32
31
30
29
28
27
26
25
24
23
22
21
20
19
18
17
16
15
14
13
12
11
10
09
08
07
06
05
04
03
02
01
00
99
98
97
96
95
94
93
92
91
90
89
88
87
86
85
84
83
82
81
80
79
78
77
76
75
74
73
72
71
70
69
68
67
66
65
64
63
62
61
60
59
58
57
56
55
54
53
52
51
50
49
48
47
46
45
44
43
42
41
40
39
38
37
36
35
34
33
32
31
30
29
28
27
26
25
24
23
22
21
20
19
18
17
16
15
14
13
12
11
10
09
08
07
06
05
04
03
02
01
00
99
98
97
96
95
94
93
92
91
90
89
88
87
86
85
84
83
82
81
80
79
78
77
76
75
74
73
72
71
70
69
68
67
66
65
64
63
62
61
60
59
58
57
56
55
5

APPROVED: 
DocuSigned by:
Gao Teng
686BA0E5257455
3/20/2019

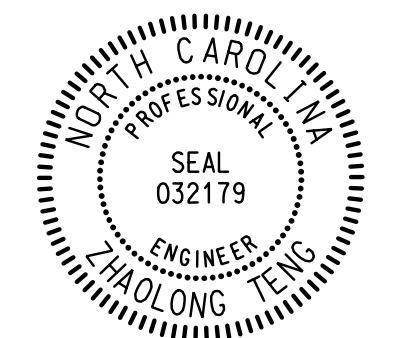
DATE: _____
 SEAL: 

**DOCUMENT NOT CONSIDERED FINAL
 UNLESS ALL SIGNATURES COMPLETED**

PREPARED IN THE OFFICE OF:
 **Accelerate Engineering, PLLC**
 875 Walnut Street, Suite 316
 Cary, NC 27511
 Tel: 919.263.5678 Fax: 919.263.5687
 NC License No. P-1442

SIGN NUMBER: 316 TYPE: D QUANTITY: 1 SIGN WIDTH: 8'-6" HEIGHT: 3'-0" TOTAL AREA: 25.5 Sq.Ft. BORDER TYPE: FLUSH RECESS: 0" WIDTH: 1" RADII: 3" NO. Z BARS: _____ LENGTH: _____	BACKG COLOR: Green COPY COLOR: White SYMBOL: _____ X Y WID HT AR_Type D 6.2 19.3 6 9 AR_Type D 52.7 4.8 6 9 MAT'L: 0.125" (3.2 mm) ALUMINUM	DESIGN BY: G TENG PROJECT ID: R-2582A CHECKED BY: E THOMAS LOCATION: -L STA. 260+00 Sep 13, 2018 DIV: 1
---	--	--

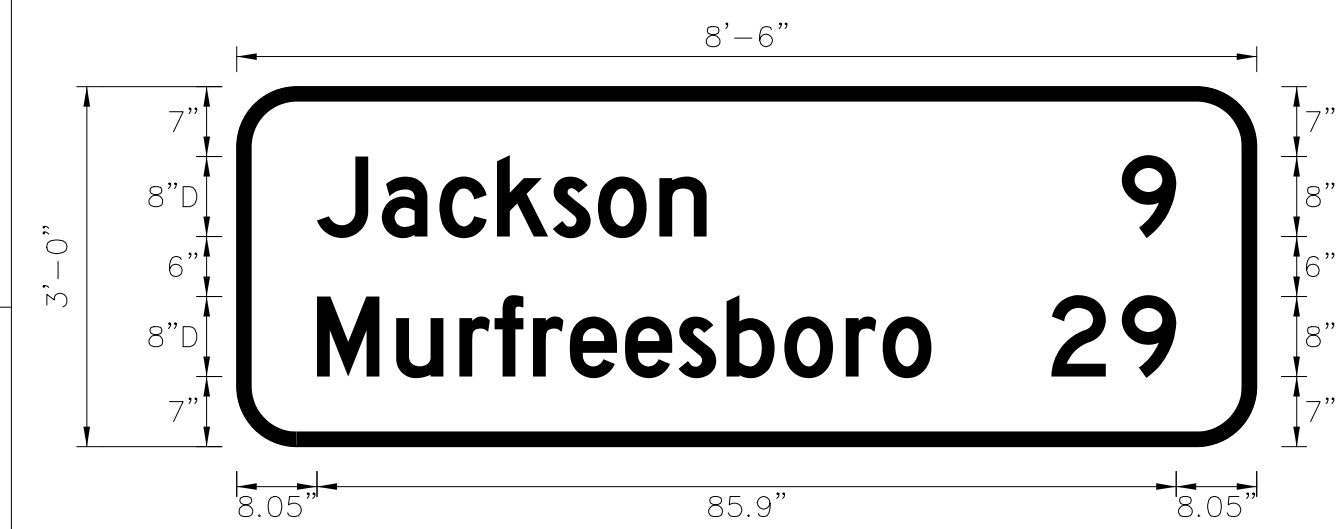

USE NOTES:
 1. Legend and border(except those that are colored black) shall be direct applied Grade C sheeting.
 2. Background shall be Grade C reflective sheeting.

Spacing Factor is 1 unless specified otherwise

LETTER POSITIONS

Letter spacings are to start of next letter

Series/Size	Text	Length
D 2000	J a c k s o n	55
D 2000	g	5.4
D 2000	M u r f r e e s b o r o	85.9

FILENAME: R-2582A_Sgn_GuideSIGN NORTH CAROLINA D.O.T. SIGN DETAIL

SIGN NUMBER: 317 TYPE: D QUANTITY: 1 SIGN WIDTH: 6'-0" HEIGHT: 2'-6" TOTAL AREA: 15.0 Sq.Ft. BORDER TYPE: FLUSH RECESS: 0" WIDTH: 0.75" RADII: 3" NO. Z BARS: _____ LENGTH: _____	BACKG COLOR: Green COPY COLOR: White SYMBOL: _____ X Y WID HT AR_Type D 6.2 19.3 6 9 AR_Type D 52.7 4.8 6 9 MAT'L: 0.125" (3.2 mm) ALUMINUM	DESIGN BY: G TENG PROJECT ID: R-2582A CHECKED BY: E THOMAS LOCATION: SEE SIGN-10 Sep 13, 2018 DIV: 1
--	--	---

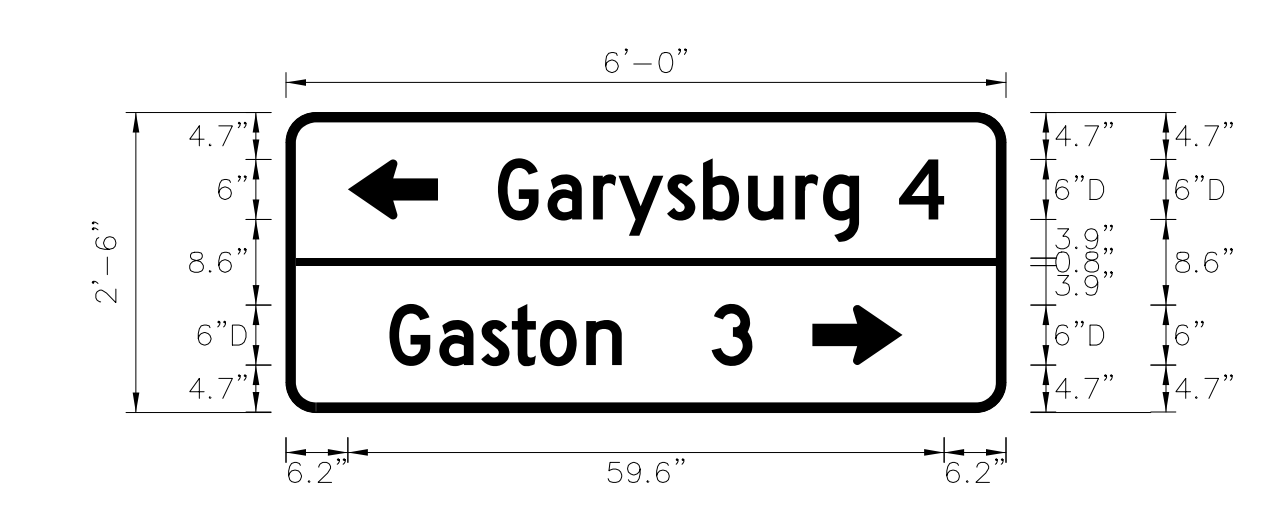

USE NOTES:
 1. Legend and border(except those that are colored black) shall be direct applied Grade C sheeting.
 2. Background shall be Grade C reflective sheeting.

Spacing Factor is 1 unless specified otherwise

LETTER POSITIONS

Letter spacings are to start of next letter

Series/Size	Text	Length
D 2000	G a r y s b u r g 4	44.6
D 2000	G a s t o n	23.2
D 2000	3	4.1

FILENAME: R-2582A_Sgn_GuideSIGN NORTH CAROLINA D.O.T. SIGN DETAIL

SIGN NUMBER: 318 TYPE: D QUANTITY: 1 SIGN WIDTH: 8'-6" HEIGHT: 3'-10" TOTAL AREA: 32.6 Sq.Ft. BORDER TYPE: FLUSH RECESS: 0" WIDTH: 0.75" RADII: 3" NO. Z BARS: _____ LENGTH: _____	BACKG COLOR: Blue COPY COLOR: White SYMBOL: _____ X Y WID HT AR_Type D 86.8 28 6 9 AR_Type D 86.8 5.5 6 9 MAT'L: 0.125" (3.2 mm) ALUMINUM	DESIGN BY: G TENG PROJECT ID: R-2582A CHECKED BY: E THOMAS LOCATION: SEE SIGN-7 Nov 16, 2018 DIV: 4
---	--	--

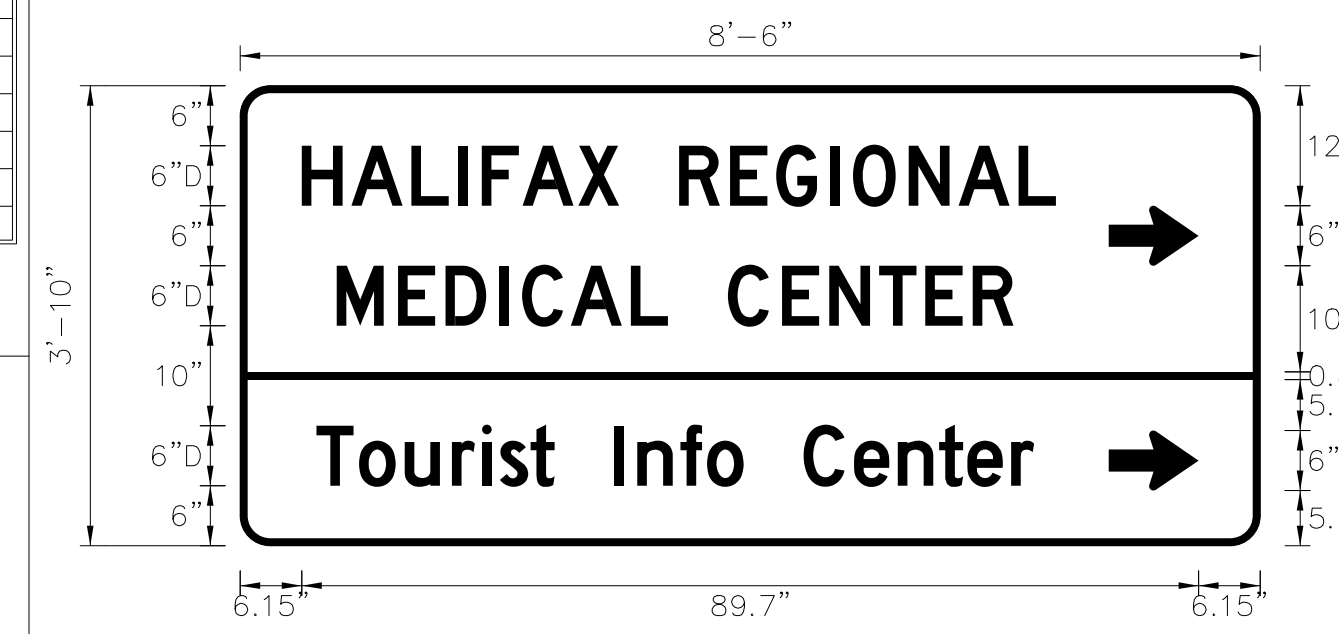

USE NOTES:
 1. Legend and border(except those that are colored black) shall be direct applied Grade C sheeting.
 2. Background shall be Grade C reflective sheeting.

Spacing Factor is 1 unless specified otherwise

LETTER POSITIONS



Letter spacings are to start of next letter

Series/Size	Text	Length
D 2000	H A L I F A X R E G I O N A L	75.4
D 2000	M E D I C A L C E N T E R	67.7
D 2000	T o u r i s t I n f o C e n t e r	71.8

FILENAME: R-2582A_Sgn_GuideSIGN NORTH CAROLINA D.O.T. SIGN DETAIL

**GROUND MOUNTED
 SIGN DESIGNS**

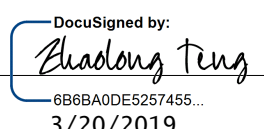
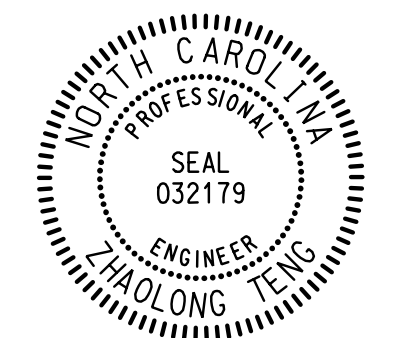
01
02
03
04
05
06
07
08
09
10
11
12
13
14
15
16
17
18
19
20
21
22
23
24
25
26
27
28
29
30
31
32
33
34
35
36
37
38
39
40
41
42
43
44
45
46
47
48
49
50
51
52
53
54
55
56
57
58
59
60
61
62
63
64
65
66
67
68
69
70
71
72
73
74
75
76
77
78
79
80
81
82
83
84
85
86
87
88
89
90
91
92
93
94
95
96
97
98
99
100

PROJECT REFERENCE NO. R-2582A	SHEET NO. SIGN-5
APPROVED:  686A00E5287455 3/20/2019	
DATE: _____	
SEAL 	
DOCUMENT NOT CONSIDERED FINAL UNLESS ALL SIGNATURES COMPLETED	
PREPARED IN THE OFFICE OF:  Accelerate Engineering, PLLC 875 Walnut Street, Suite 316 Cary, NC 27511 Tel: 919.263.5678 Fax: 919.263.5687 NC License No. P-1442	

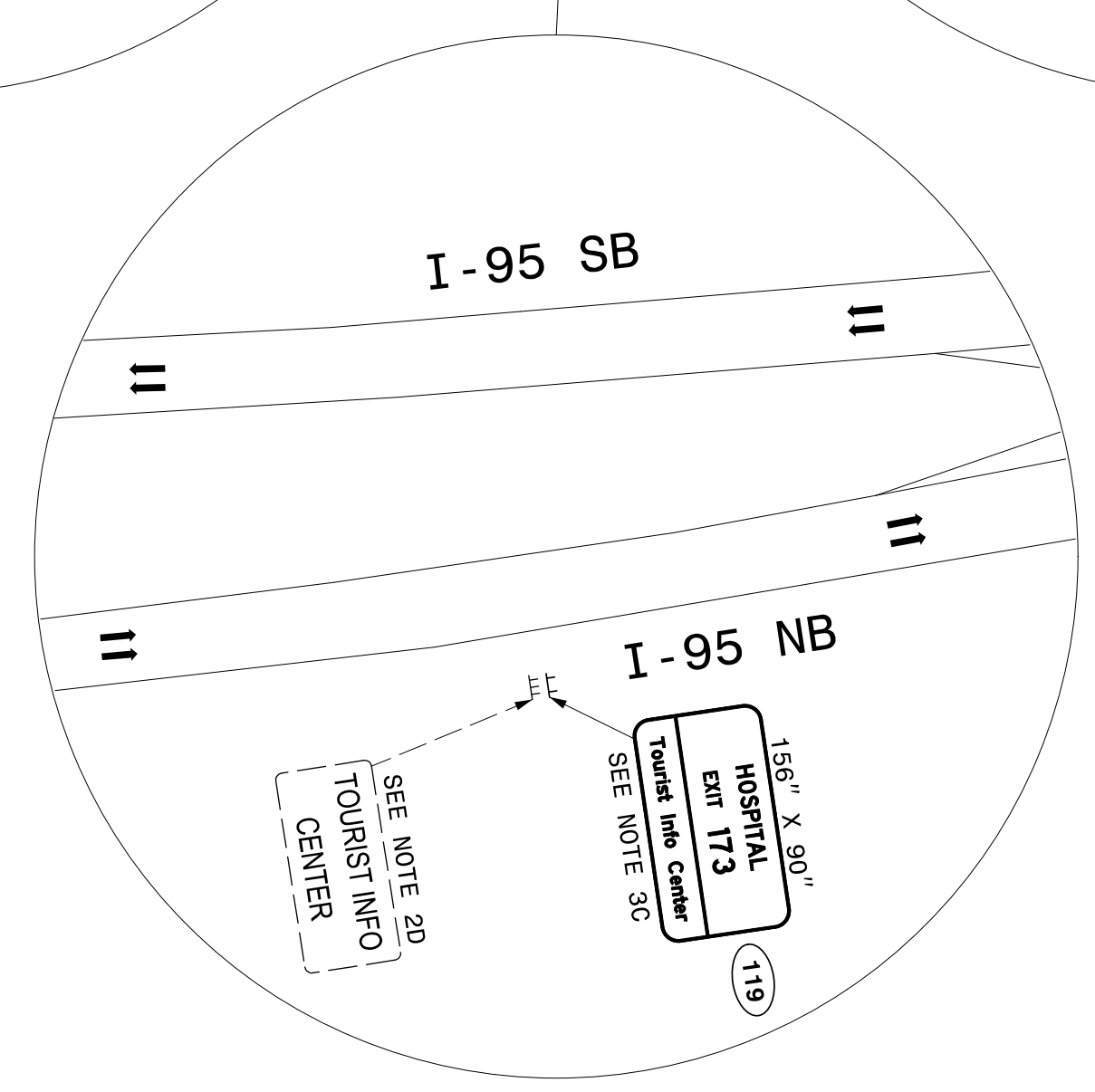
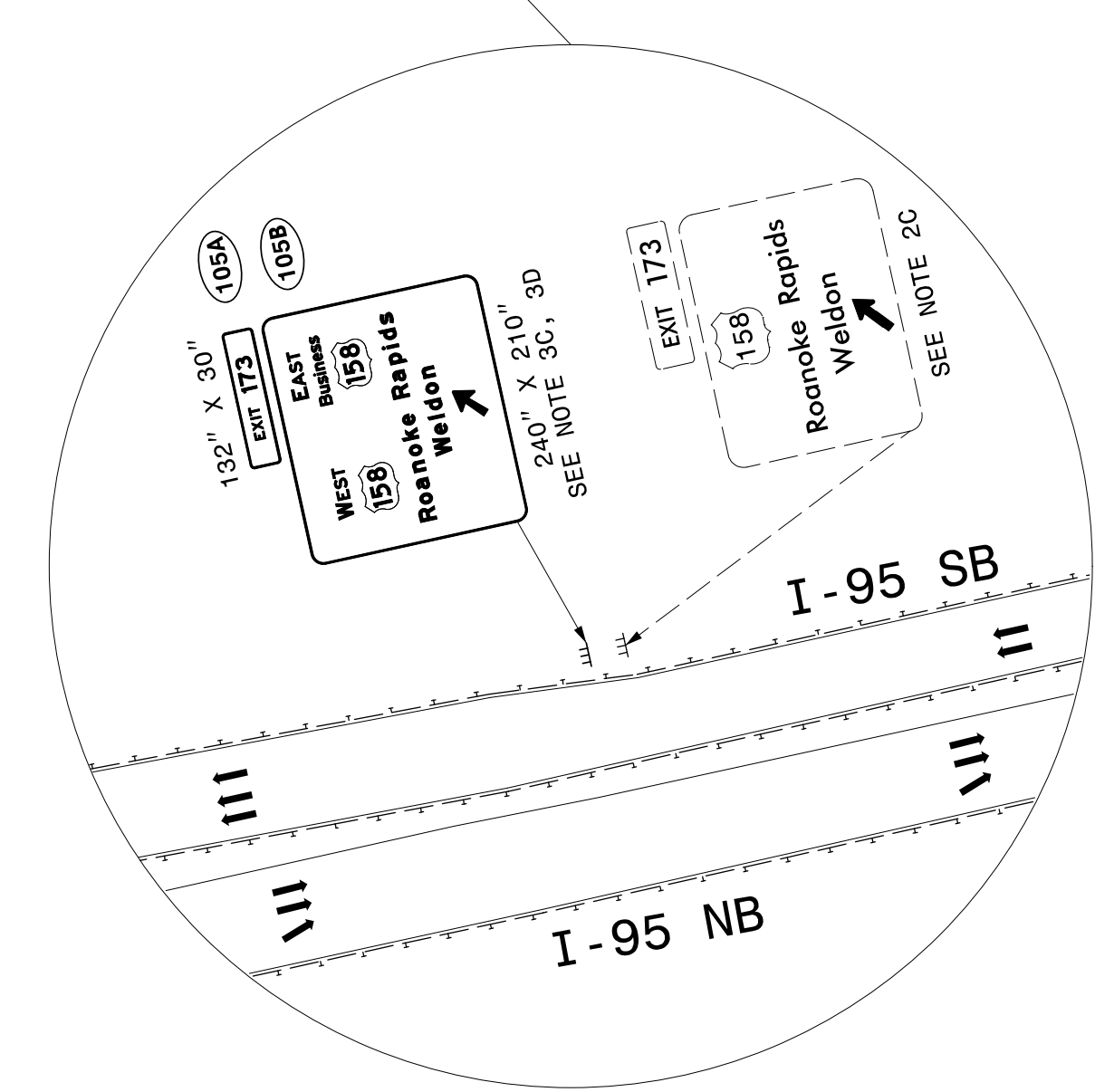
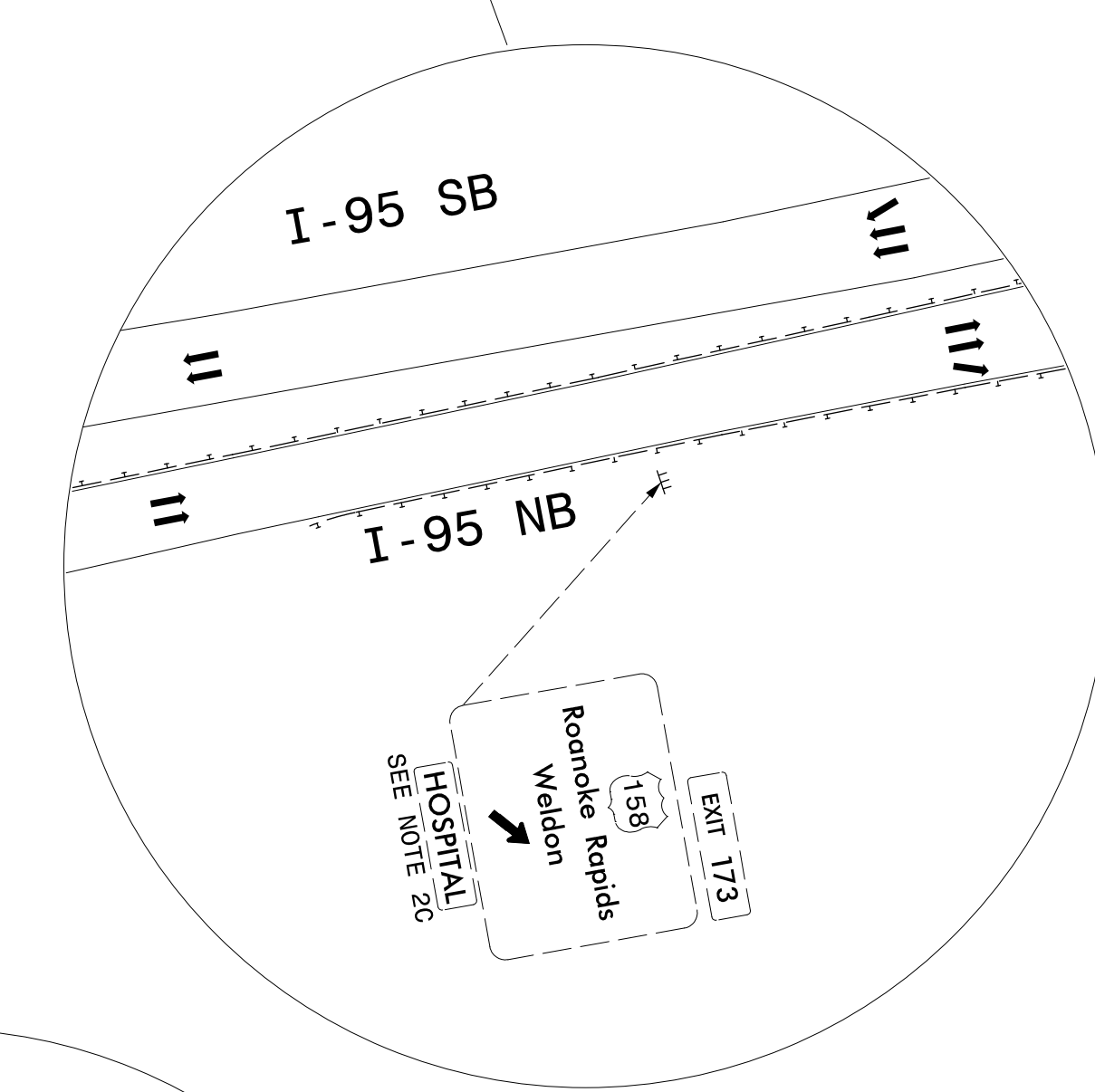
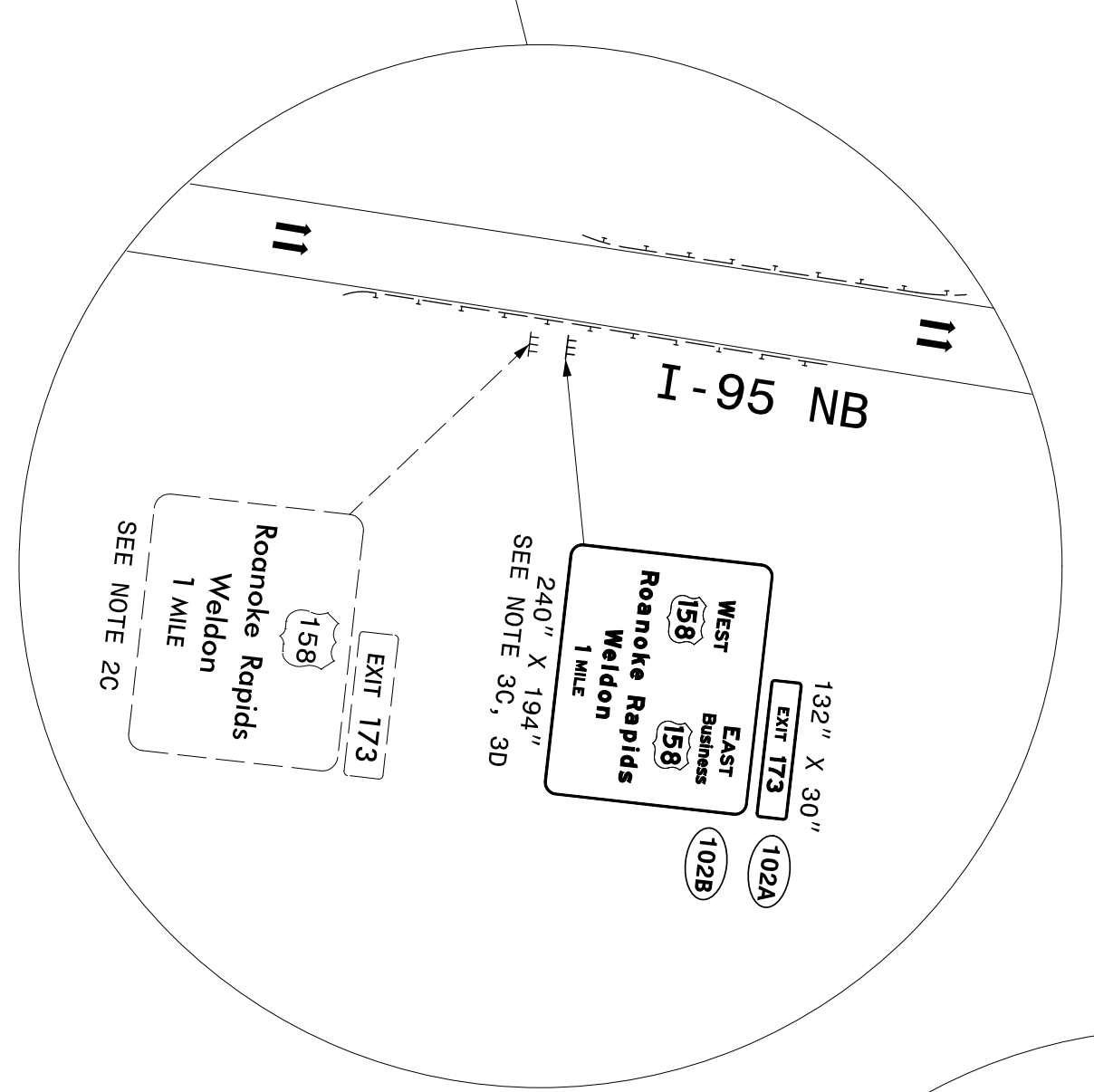
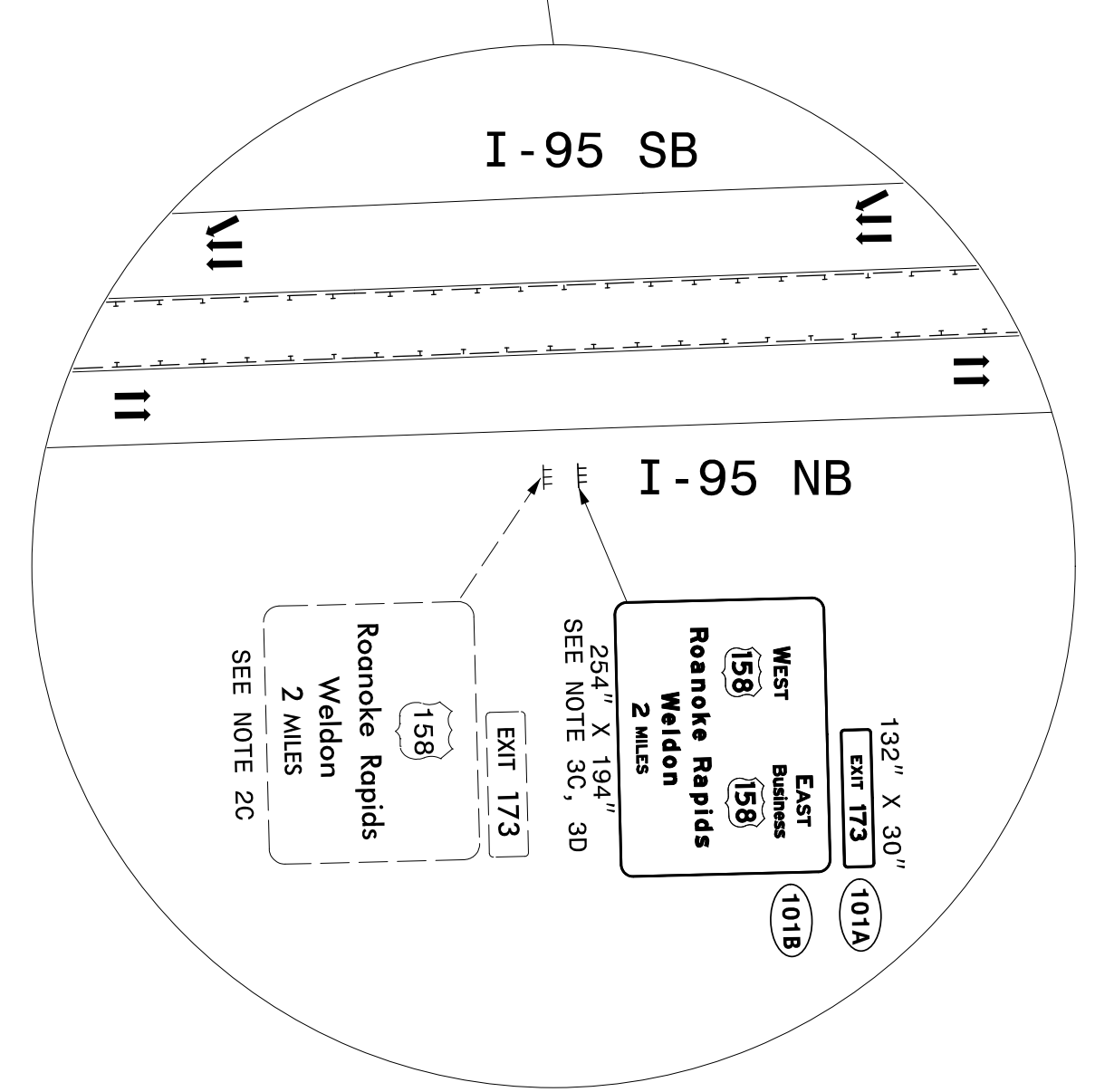
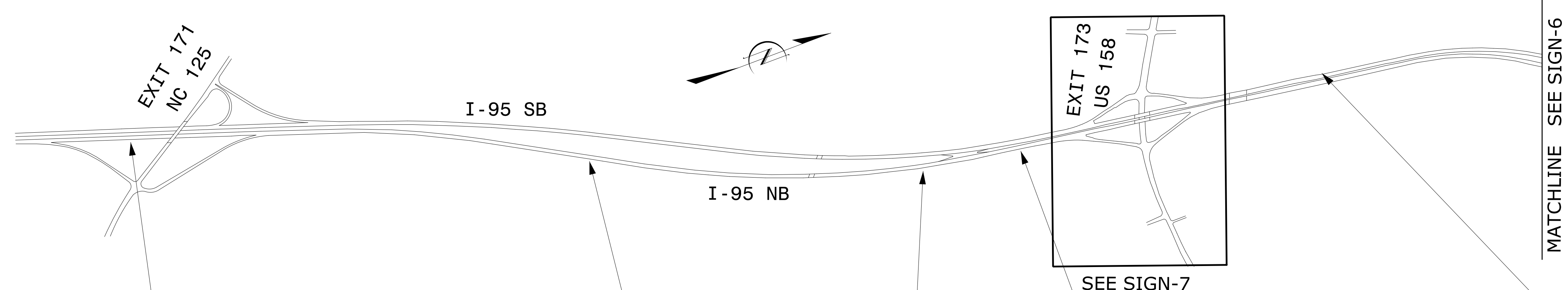

NOTE: INSTALL PROPOSED REPLACEMENT GUIDE SIGNS APPROXIMATELY 10 FEET BEHIND EXISTING SIGNS.

**EXISTING & PROPOSED SIGNS
I-95 IN HALIFAX COUNTY**

11/15/19

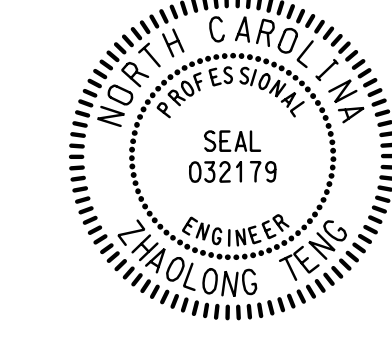
PROJECT REFERENCE NO. R-2582A	SHEET NO. SIGN-6
APPROVED: <i>Shaolong Teng</i> 032179 3/20/2019	
DATE: 3/20/2019	
SEAL 	
DOCUMENT NOT CONSIDERED FINAL UNLESS ALL SIGNATURES COMPLETED	
PREPARED IN THE OFFICE OF: Accelerate Engineering, PLLC 875 Walnut Street, Suite 316 Cary, NC 27511 Tel: 919.263.5678 Fax: 919.263.5687 NC License No. P-1442	

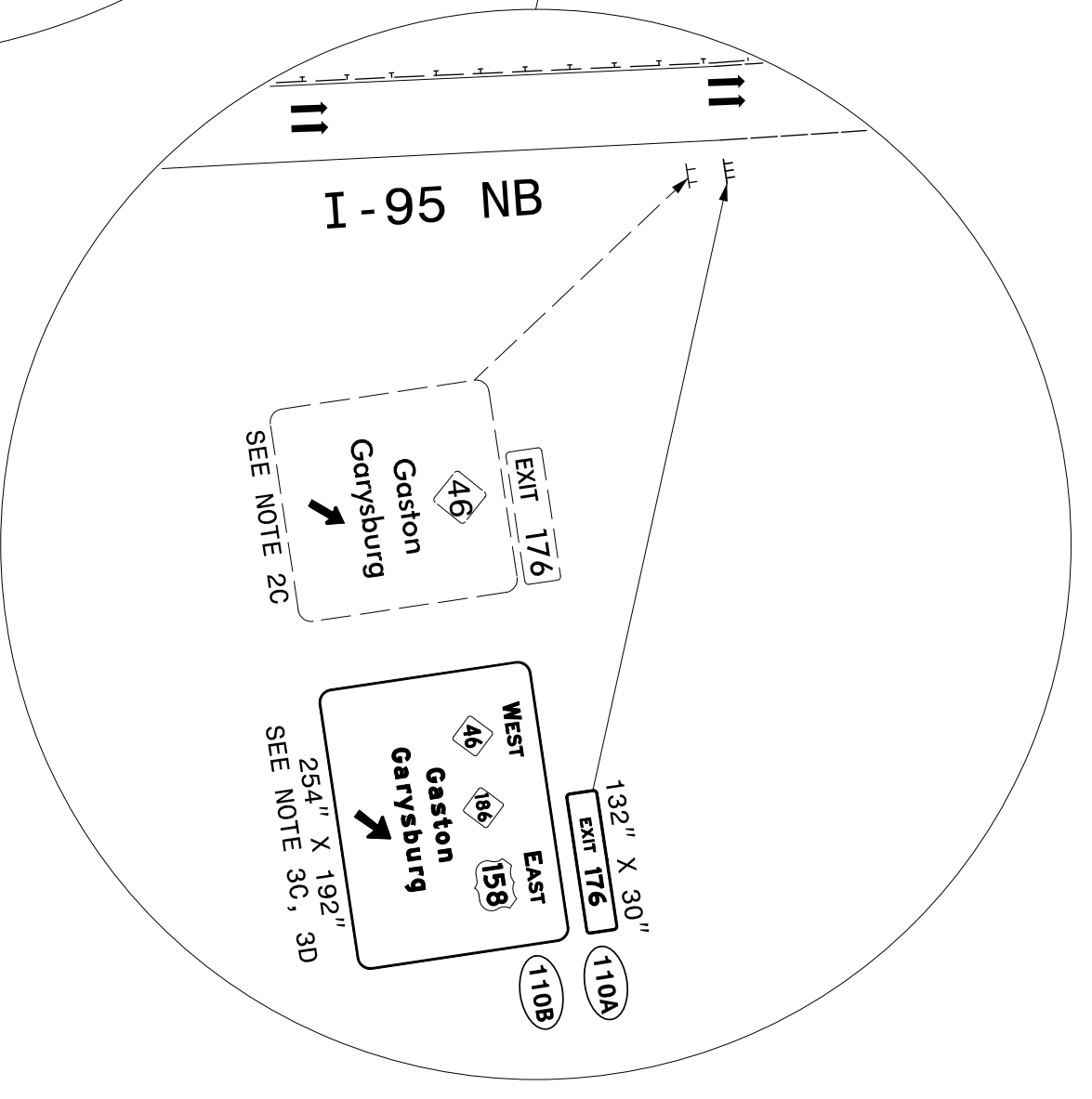
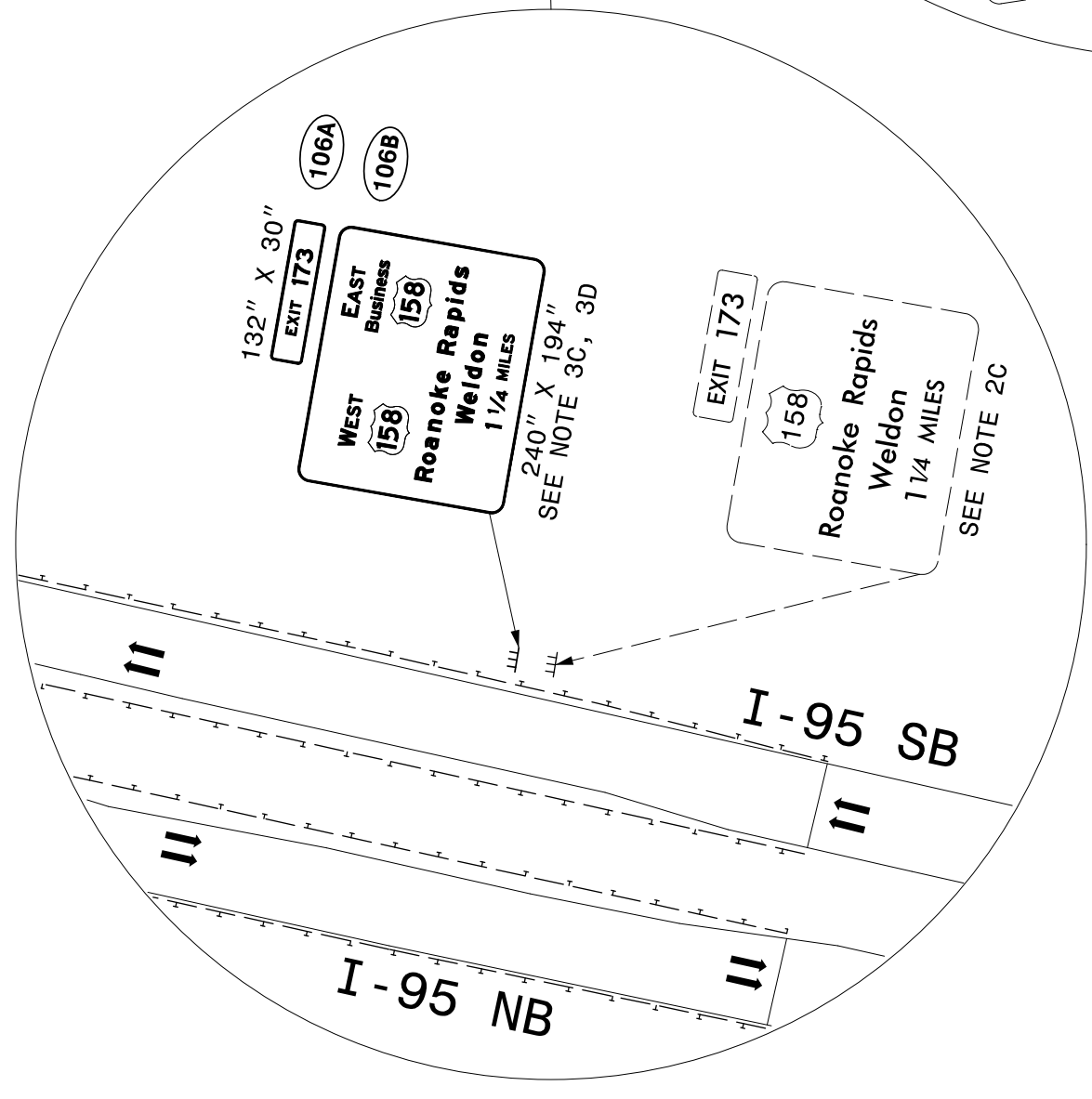
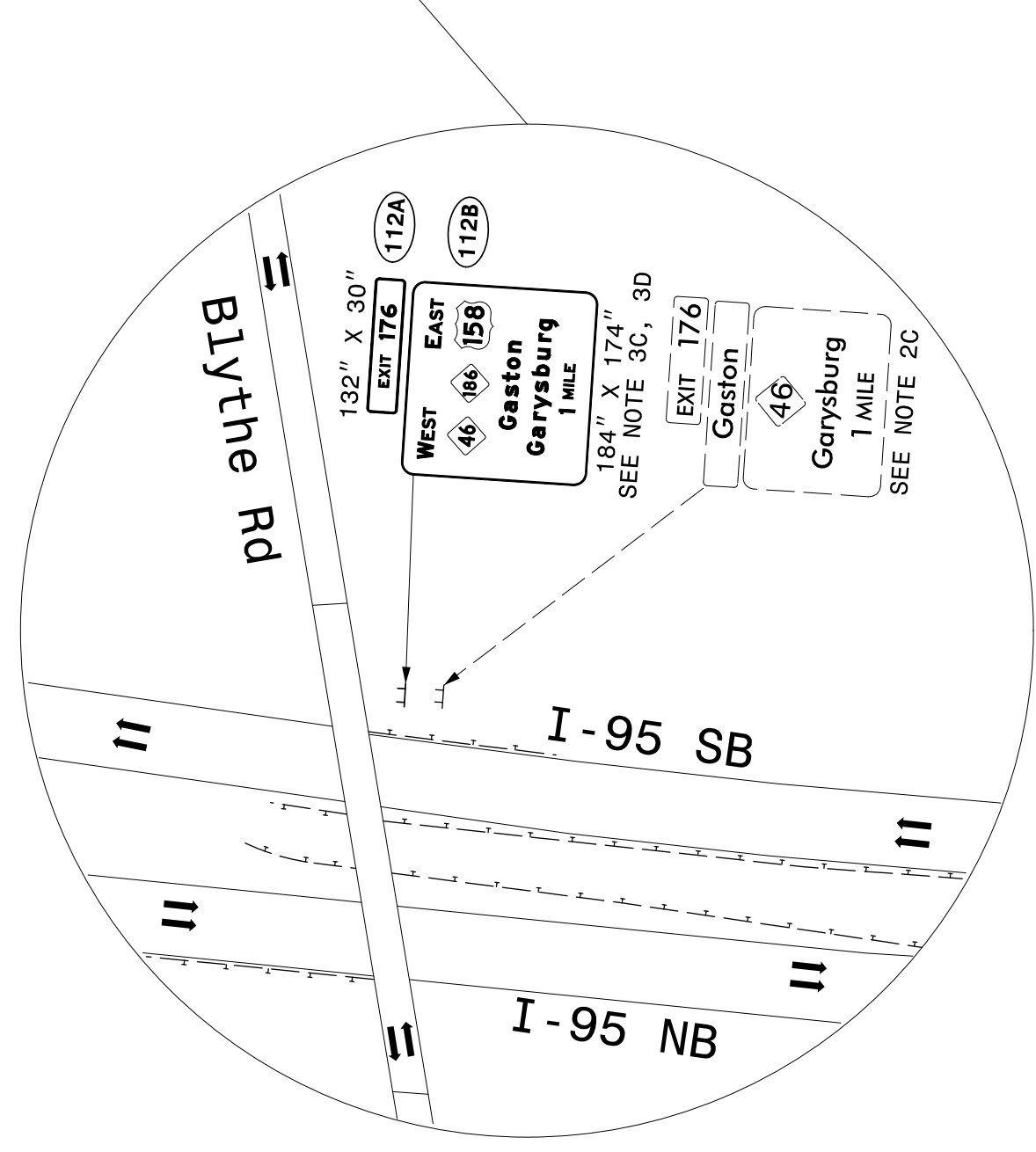
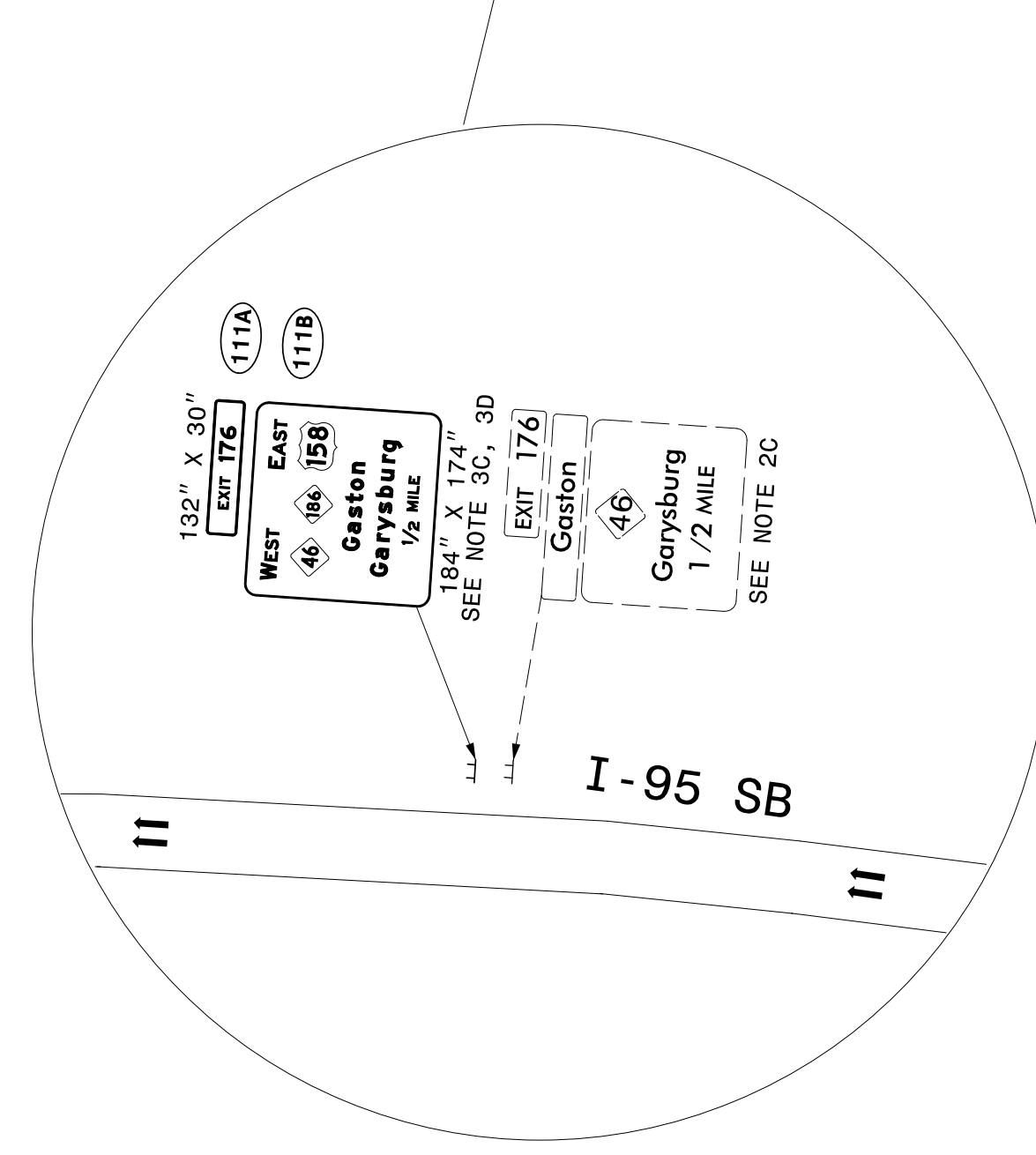
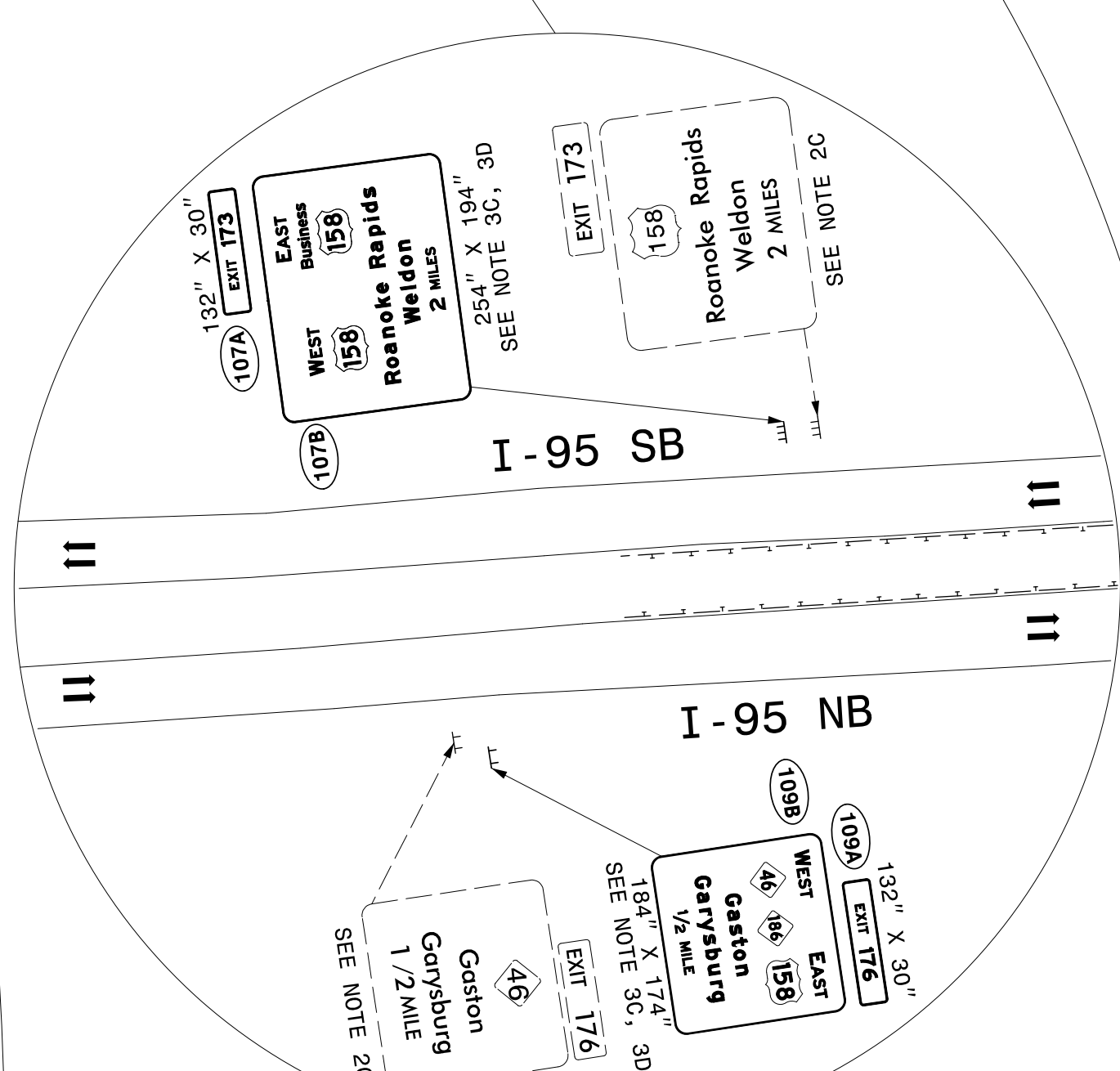
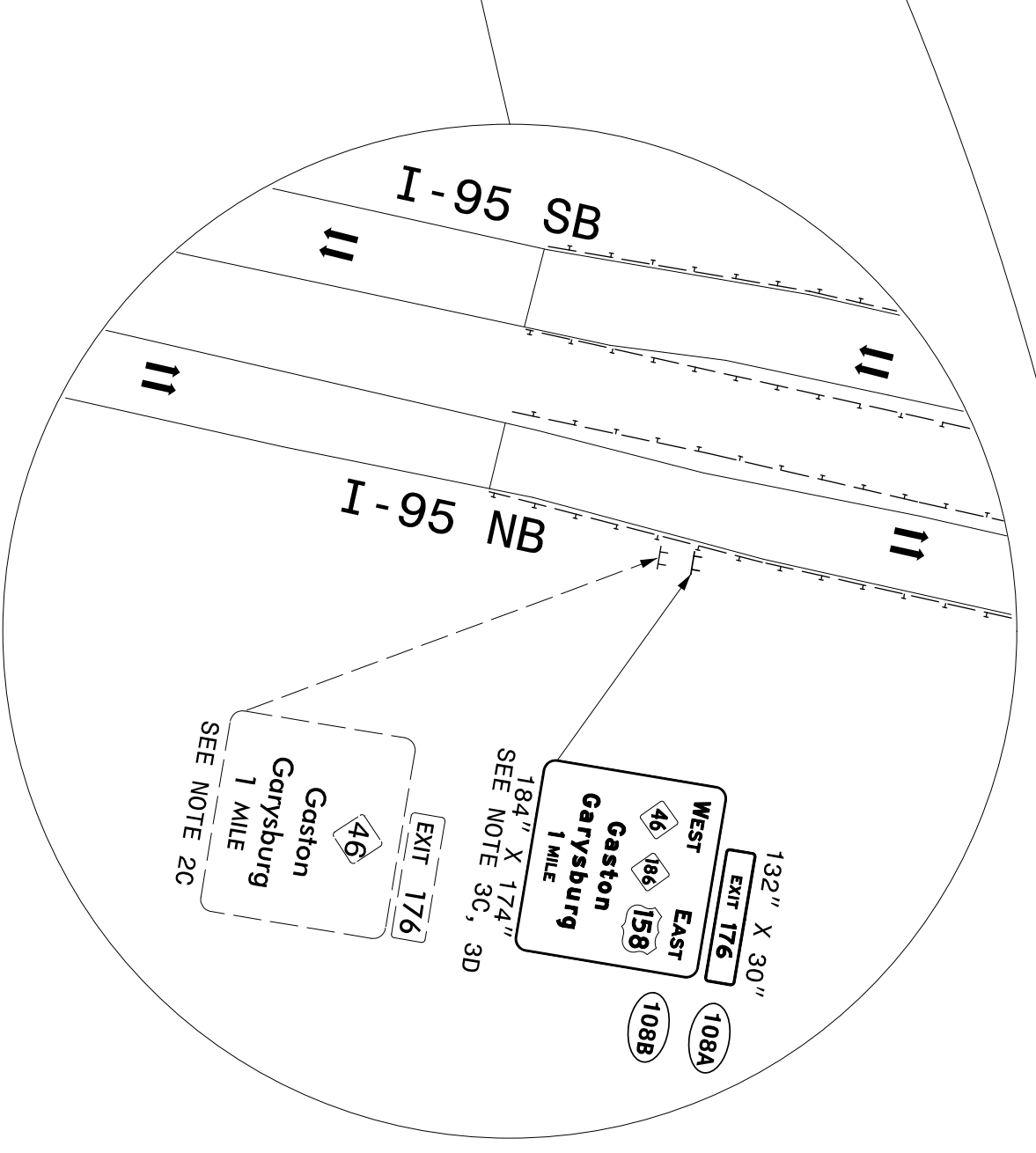

NOTE: INSTALL PROPOSED REPLACEMENT GUIDE SIGNS APPROXIMATELY 10 FEET BEHIND EXISTING SIGNS.

**EXISTING & PROPOSED SIGNS
I-95 IN NORTHAMPTON COUNTY**

11/15/2019 11:52 AM

SEE SHEET 9 MATCHLINE A

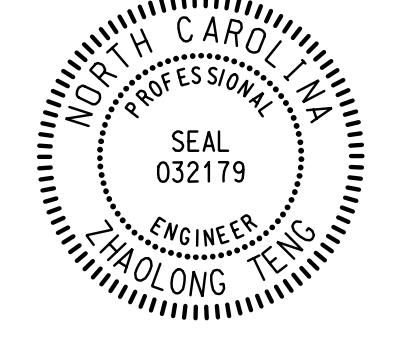
PROJECT REFERENCE NO. R-2582A	SHEET NO. SIGN-8
APPROVED: <i>Guangrong Teng</i> 3/20/2019	
DATE: _____	
SEAL 	
DOCUMENT NOT CONSIDERED FINAL UNLESS ALL SIGNATURES COMPLETED	
PREPARED IN THE OFFICE OF: Accelerate Engineering, PLLC 875 Walnut Street, Suite 316 Cary, NC 27511 Tel: 919.263.5678 Fax: 919.263.5687 NC License No. P-1442	

SEE SHEET 9 MATCHLINE B

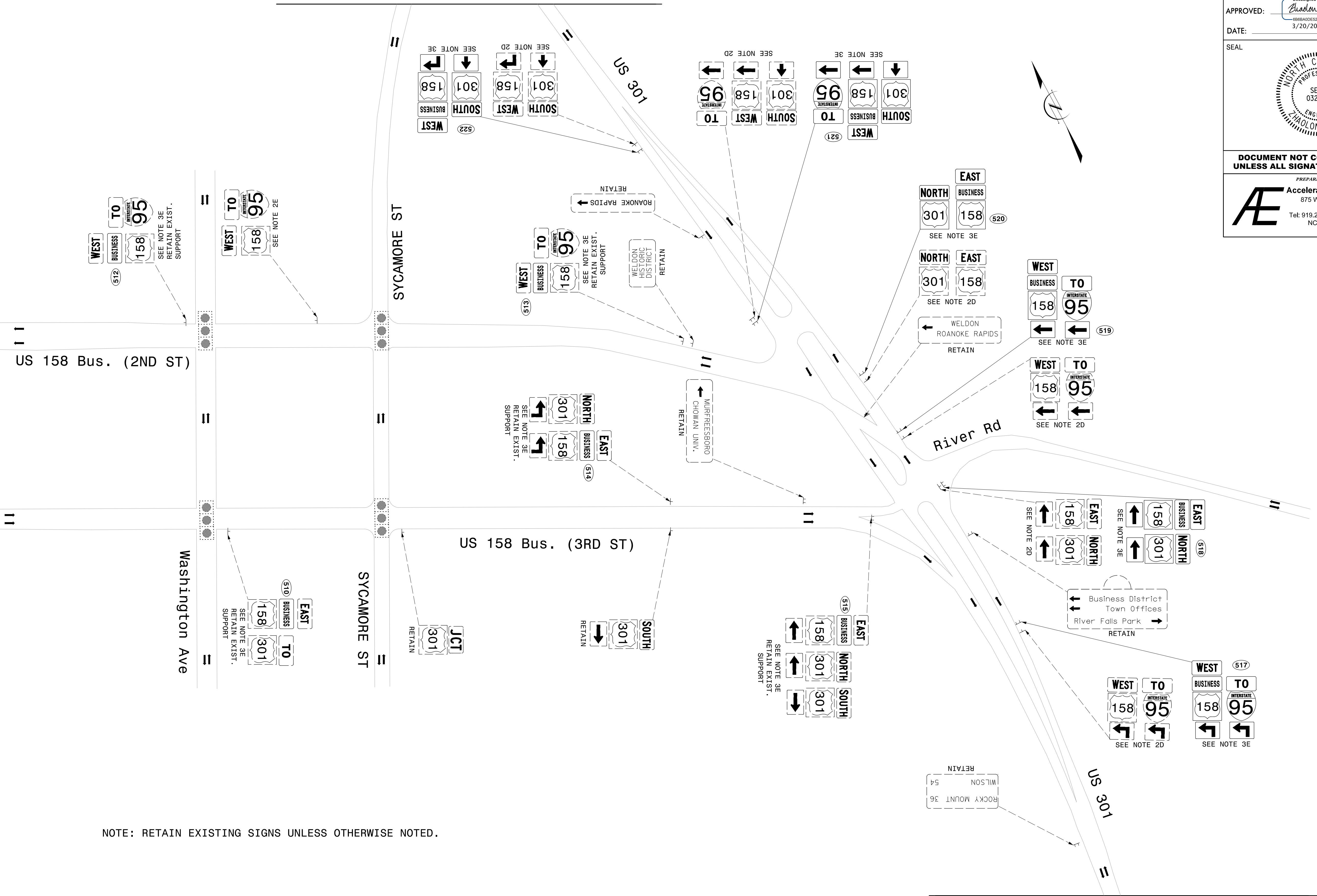

NOTE: RETAIN EXISTING SIGNS UNLESS OTHERWISE NOTED.

SEE SHEET 9 MATCHLINE C

**EXISTING & PROPOSED SIGNS
WELDON AREA**

54
53
52
51
50
49
48
47
46
45
44
43
42
41
40
39
38
37
36
35
34
33
32
31
30
29
28
27
26
25
24
23
22
21
20
19
18
17
16
15
14
13
12
11
10
9
8
7
6
5
4
3
2
1

NOTE: RETAIN EXISTING SIGNS UNLESS OTHERWISE NOTED.

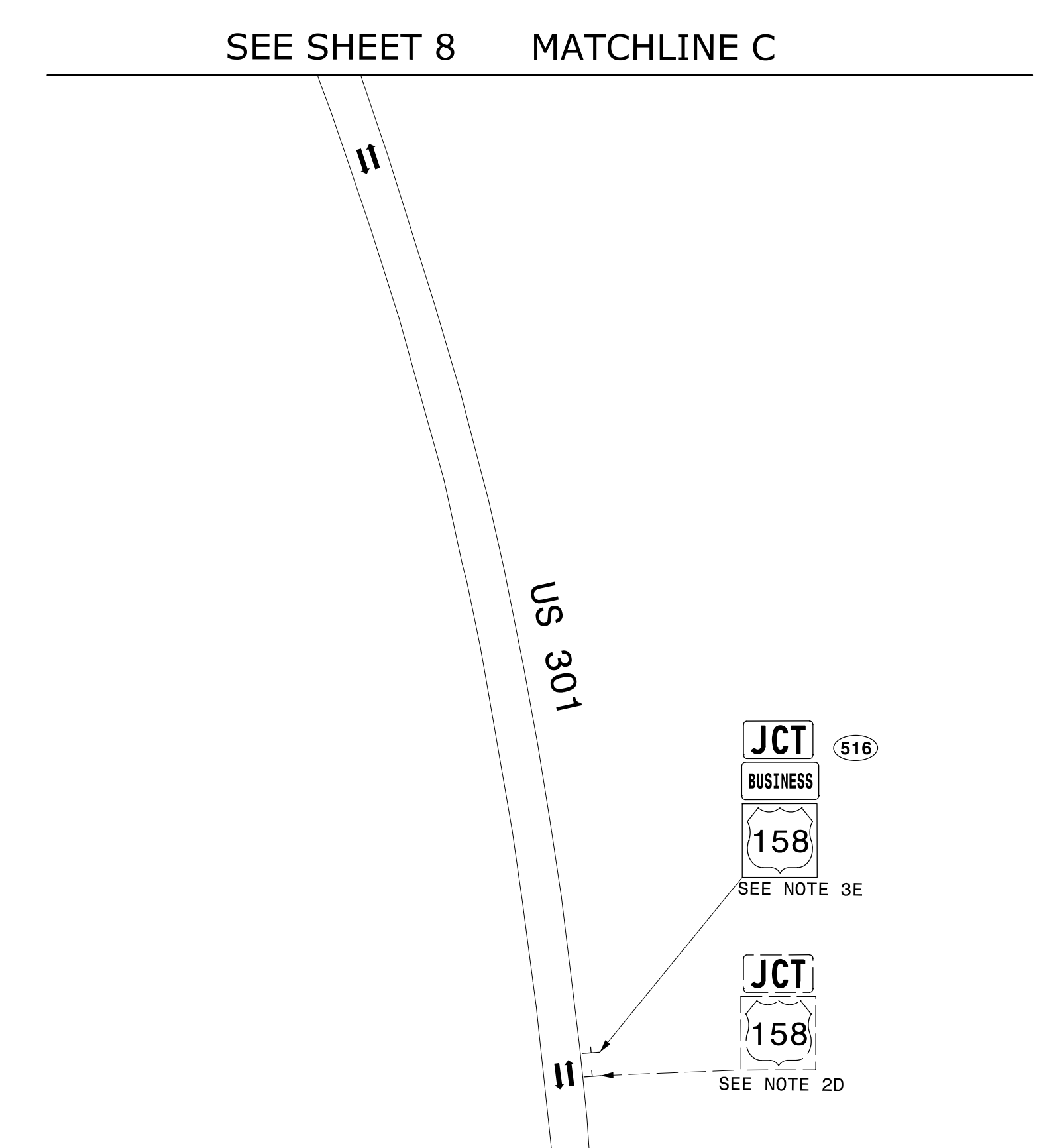
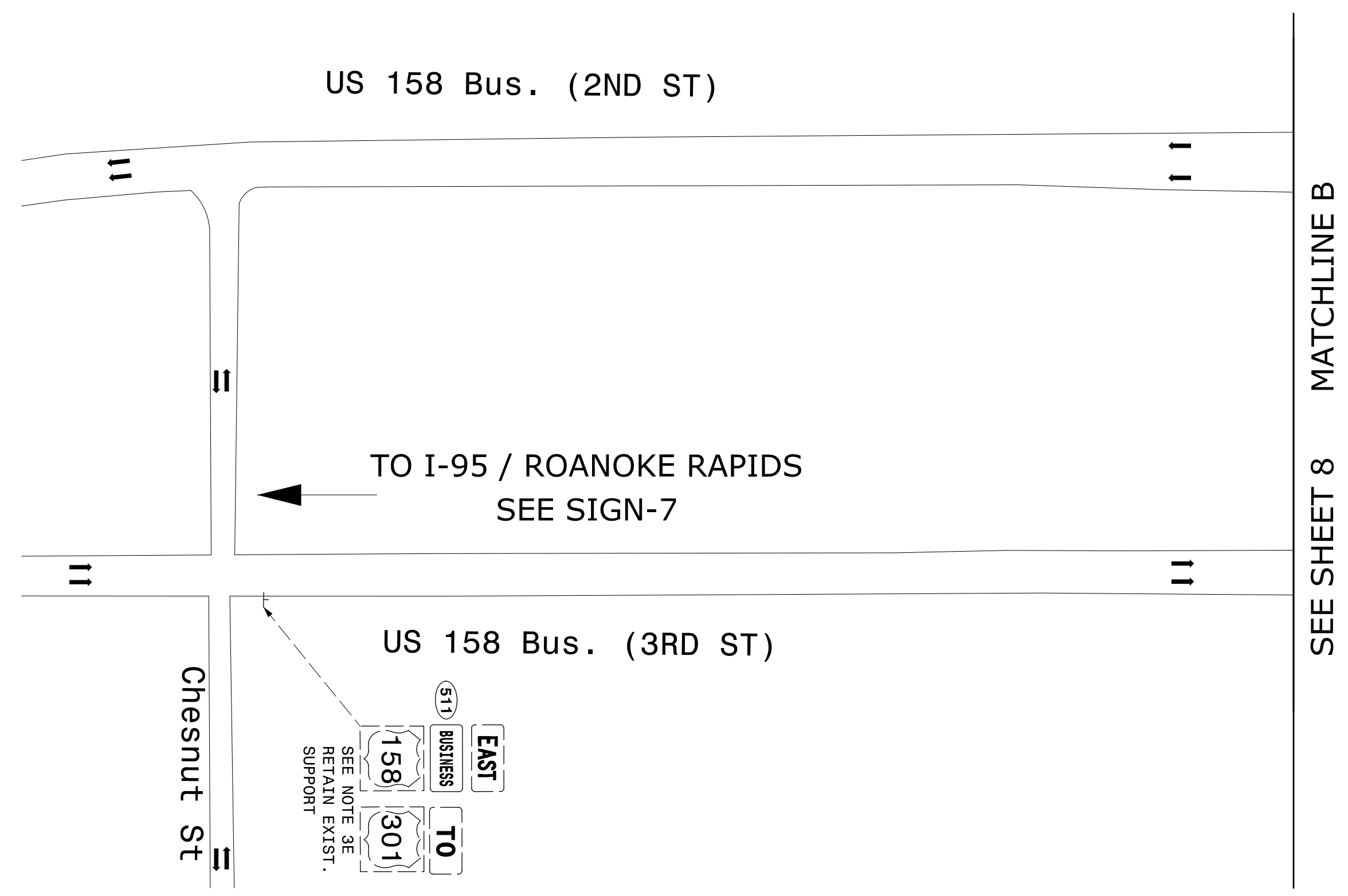
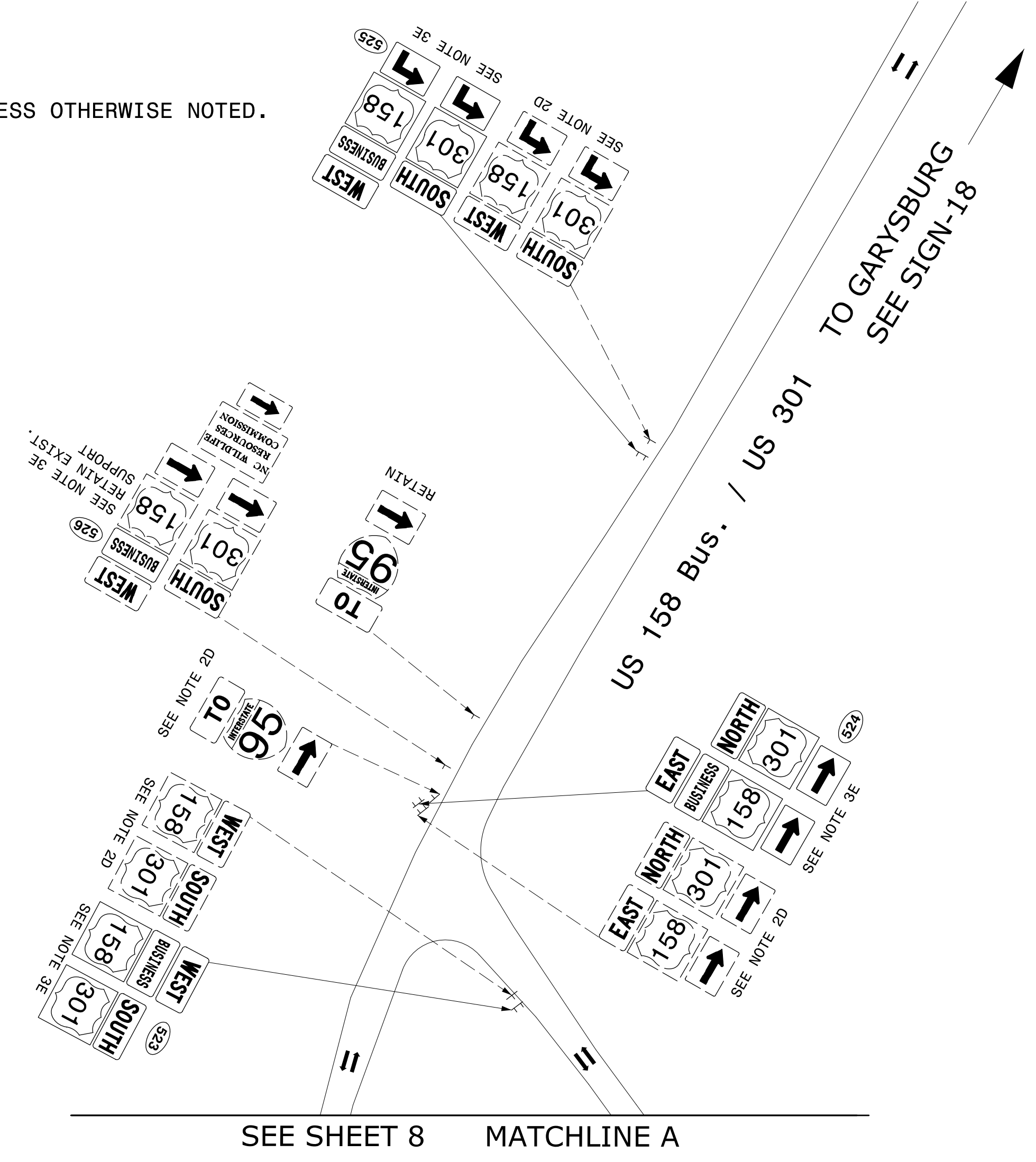

**EXISTING & PROPOSED SIGNS
WELDON AREA**

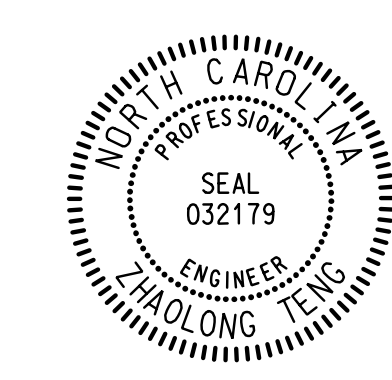
PROJECT REFERENCE NO. R-2582A	SHEET NO. SIGN-9
APPROVED: <i>Zhaolong Teng</i> 6668400E5257455 3/20/2019	
DATE: 3/20/2019	
SEAL 	
DOCUMENT NOT CONSIDERED FINAL UNLESS ALL SIGNATURES COMPLETED	
PREPARED IN THE OFFICE OF: Accelerate Engineering, PLLC 875 Walnut Street, Suite 316 Cary, NC 27511 Tel: 919.263.5678 Fax: 919.263.5687 NC License No. P-1442	

11/15/19 11:57 AM

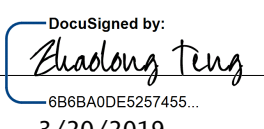
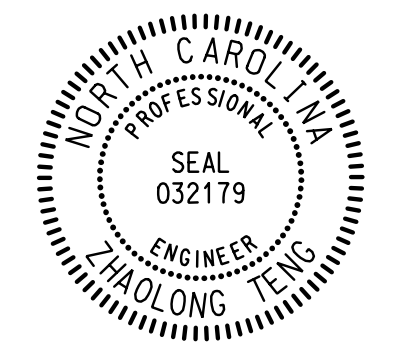
PROJECT REFERENCE NO. R-2582A	SHEET NO. SIGN-10
APPROVED:  DocuSigned by: Zhaolong Teng 6B6BA0DE5257455	
DATE: 3/20/2019	
SEAL 	
DOCUMENT NOT CONSIDERED FINAL UNLESS ALL SIGNATURES COMPLETED	
PREPARED IN THE OFFICE OF: Accelerate Engineering, PLLC 875 Walnut Street, Suite 316 Cary, NC 27511 Tel: 919.263.5678 Fax: 919.263.5687 NC License No. P-1442	

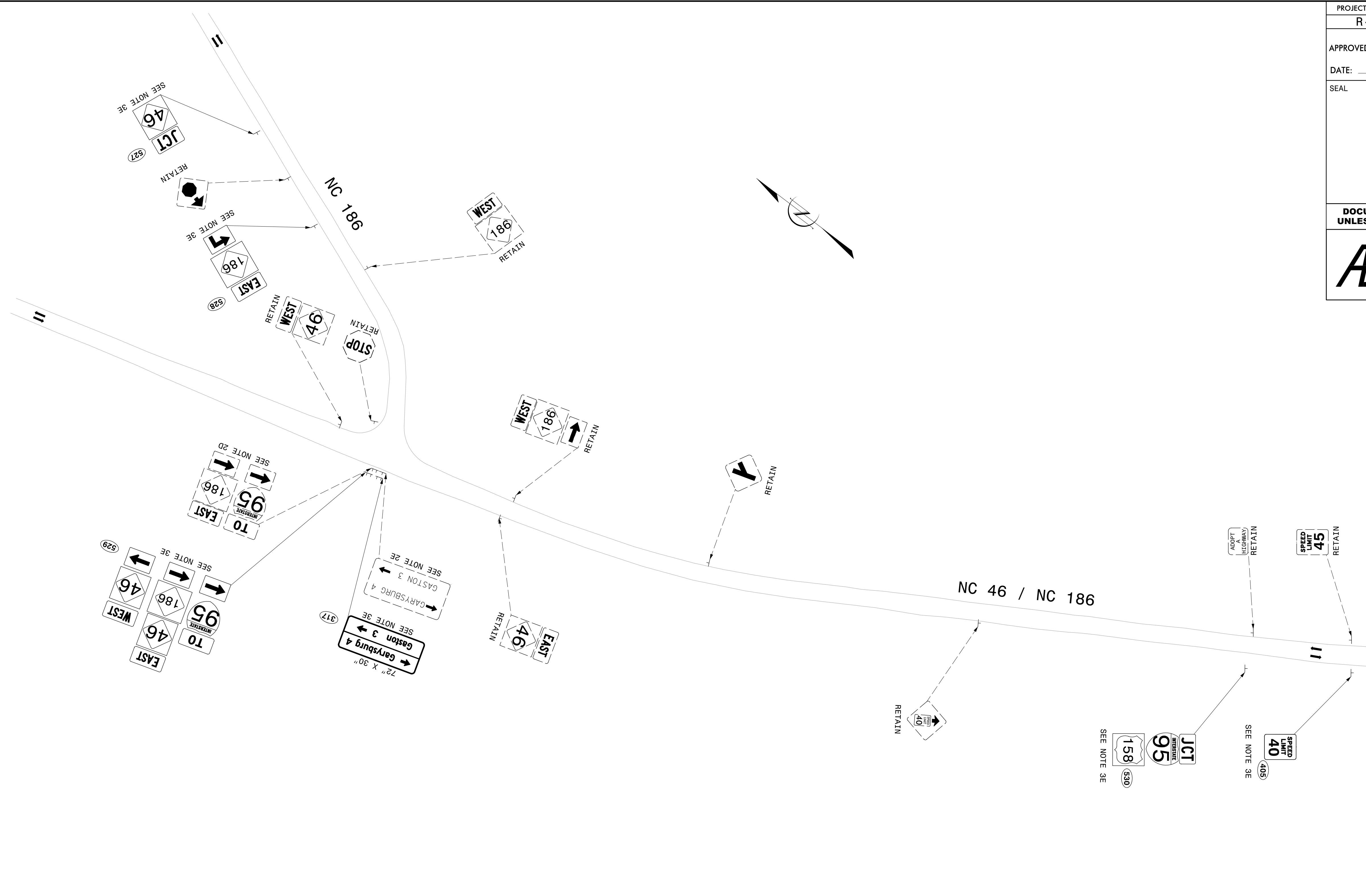

55
56
57
58
59
60
61
62
63
64
65
66
67
68
69
70
71
72
73
74
75
76
77
78
79
80
81
82
83
84
85
86
87
88
89
90
91
92
93
94
95
96
97
98
99
00

**EXISTING & PROPOSED SIGNS
NC 46 WEST OF I-95**

PROJECT REFERENCE NO. R-2582A	SHEET NO. SIGN-11
APPROVED: <i>Bladong Teng</i> 0866A00E5287455	
DATE: 3/20/2019	
SEAL	
DOCUMENT NOT CONSIDERED FINAL UNLESS ALL SIGNATURES COMPLETED	
PREPARED IN THE OFFICE OF: Accelerate Engineering, PLLC 875 Walnut Street, Suite 316 Cary, NC 27511 Tel: 919.263.5678 Fax: 919.263.5687 NC License No. P-1442	

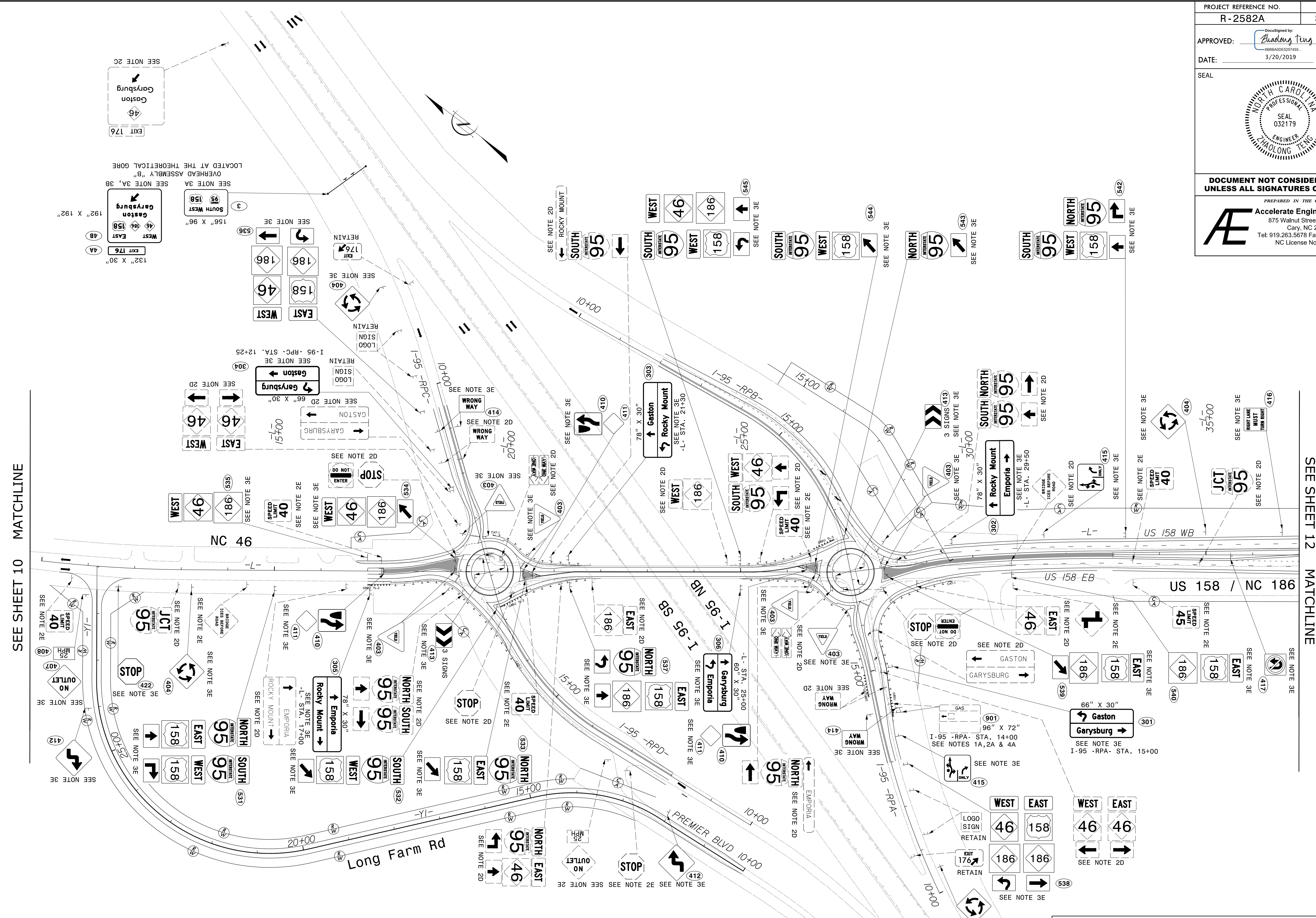



SEE SHEET 10 MATCHLINE

SEE SHEET 12 MATCHLINE

**EXISTING & PROPOSED SIGNS
-L- STA. 10+00 TO 37+00**

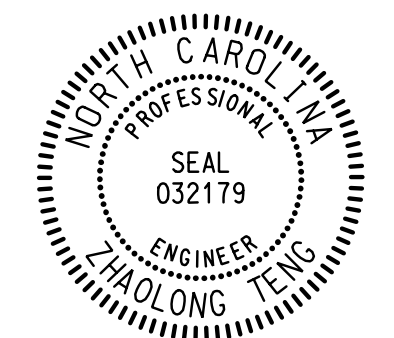
11
12
13
14
15
16
17
18
19
20
21
22
23
24
25
26
27
28
29
30
31
32
33
34
35
36
37
38
39
40
41
42
43
44
45
46
47
48
49
50
51
52
53
54
55
56
57
58
59
60
61
62
63
64
65
66
67
68
69
70
71
72
73
74
75
76
77
78
79
80
81
82
83
84
85
86
87
88
89
90
91
92
93
94
95
96
97
98
99
100

PROJECT REFERENCE NO. R-2582A	SHEET NO. SIGN-12
APPROVED: <i>Zhaolong Teng</i> DocuSigned by: Zhaolong Teng 6B8BA0DE5257455	
DATE: 3/20/2019	
SEAL 	
DOCUMENT NOT CONSIDERED FINAL UNLESS ALL SIGNATURES COMPLETED	
PREPARED IN THE OFFICE OF:  Accelerate Engineering, PLLC 875 Walnut Street, Suite 316 Cary, NC 27511 Tel: 919.263.5678 Fax: 919.263.5687 NC License No. P-1442	

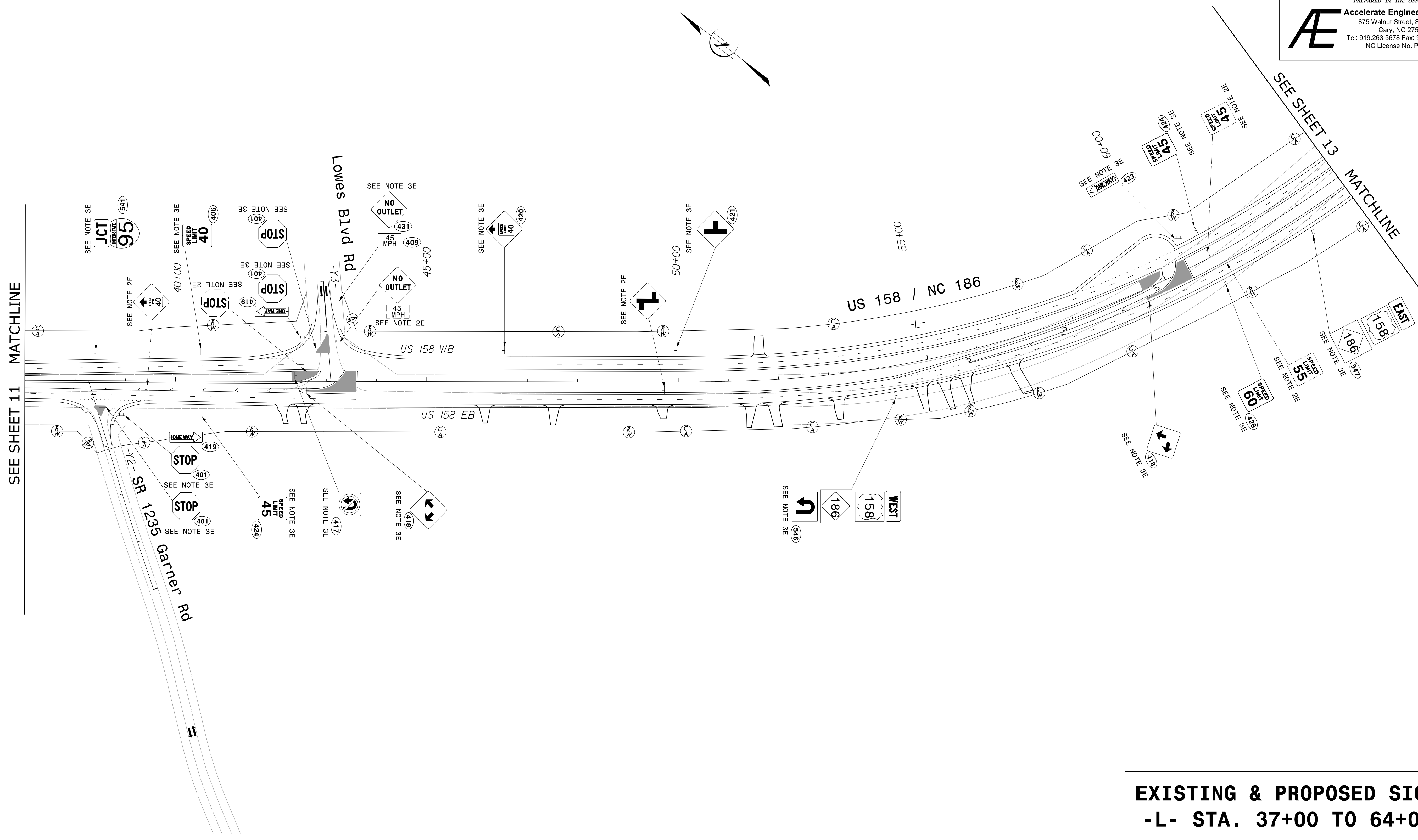

**EXISTING & PROPOSED SIGNS
-L- STA. 37+00 TO 64+00**

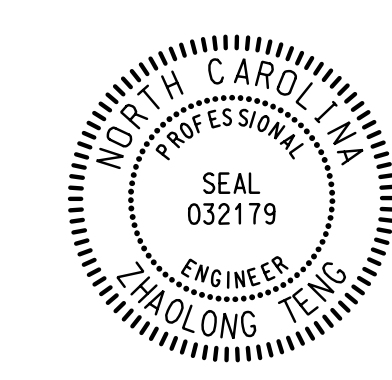

11 12 13 14 15 16 17 18 19 20 21 22 23 24 25 26 27 28 29 30 31 32 33 34 35 36 37 38 39 40 41 42 43 44 45 46 47 48 49 50 51 52 53 54 55 56 57 58 59 60 61 62 63 64 65 66 67 68 69 70 71 72 73 74 75 76 77 78 79 80 81 82 83 84 85 86 87 88 89 90 91 92 93 94 95 96 97 98 99 100

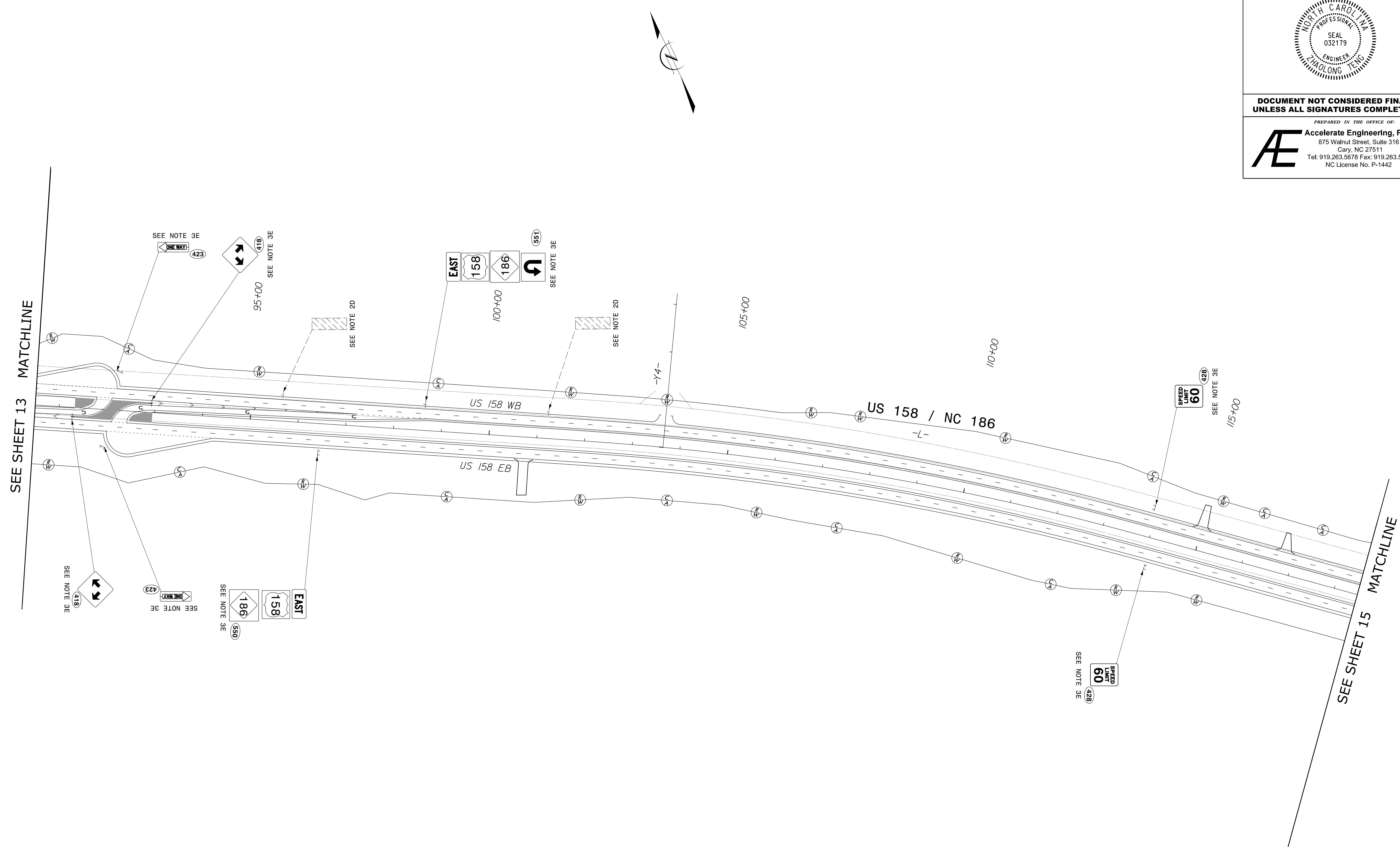
PROJECT REFERENCE NO. R-2582A	SHEET NO. SIGN-14
APPROVED: <i>Zhaolong Teng</i> <small>DocuSigned by: Zhaolong Teng 666BA0DE5257455 3/20/2019</small>	
DATE: 3/20/2019	
SEAL 	
DOCUMENT NOT CONSIDERED FINAL UNLESS ALL SIGNATURES COMPLETED	
PREPARED IN THE OFFICE OF: Accelerate Engineering, PLLC 875 Walnut Street, Suite 316 Cary, NC 27511 Tel: 919.263.5678 Fax: 919.263.5687 NC License No. P-1442	

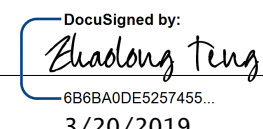

**EXISTING & PROPOSED SIGNS
-L- STA. 90+50 TO 118+50**

11
12
13
14
15
16
17
18
19
20
21
22
23
24
25
26
27
28
29
30
31
32
33
34
35
36
37
38
39
40
41
42
43
44
45
46
47
48
49
50
51
52
53
54
55
56
57
58
59
60
61
62
63
64
65
66
67
68
69
70
71
72
73
74
75
76
77
78
79
80
81
82
83
84
85
86
87
88
89
90
91
92
93
94
95
96
97
98
99
100

PROJECT REFERENCE NO. R-2582A	SHEET NO. SIGN-15
APPROVED:  3/20/2019	
DATE: 3/20/2019	
SEAL 	
DOCUMENT NOT CONSIDERED FINAL UNLESS ALL SIGNATURES COMPLETED	
PREPARED IN THE OFFICE OF:  Accelerate Engineering, PLLC 875 Walnut Street, Suite 316 Cary, NC 27511 Tel: 919.263.5678 Fax: 919.263.5687 NC License No. P-1442	

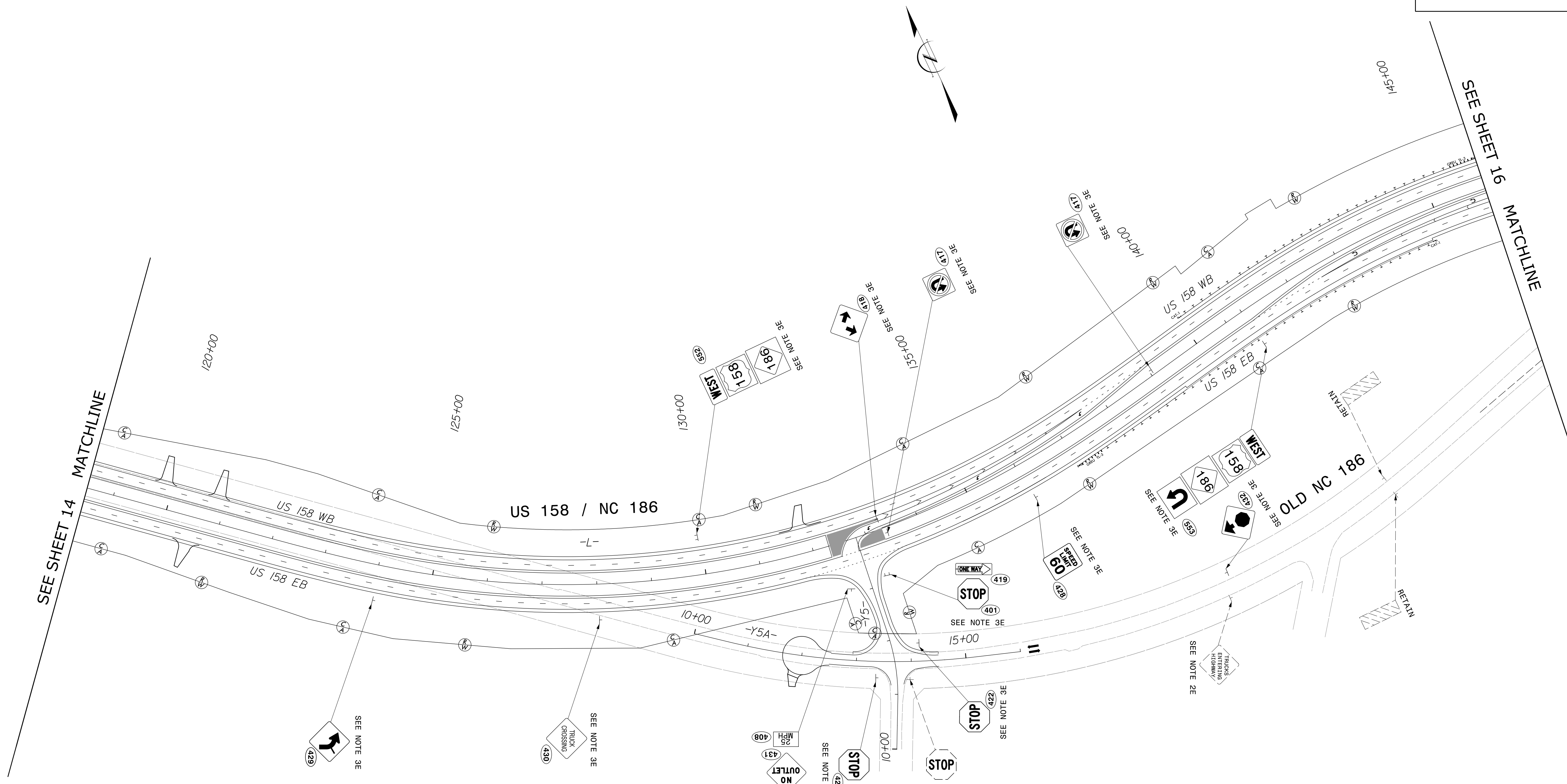

**EXISTING & PROPOSED SIGNS
-L- STA. 118+50 TO 146+00**

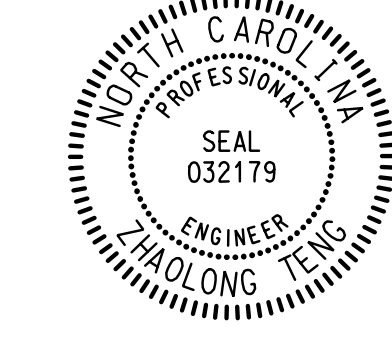
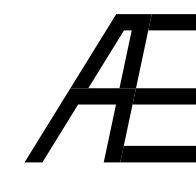

11
12
13
14
15
16
17
18
19
20
21
22
23
24
25
26
27
28
29
30
31
32
33
34
35
36
37
38
39
40
41
42
43
44
45
46
47
48
49
50
51
52
53
54
55
56
57
58
59
60
61
62
63
64
65
66
67
68
69
70
71
72
73
74
75
76
77
78
79
80
81
82
83
84
85
86
87
88
89
90
91
92
93
94
95
96
97
98
99
100

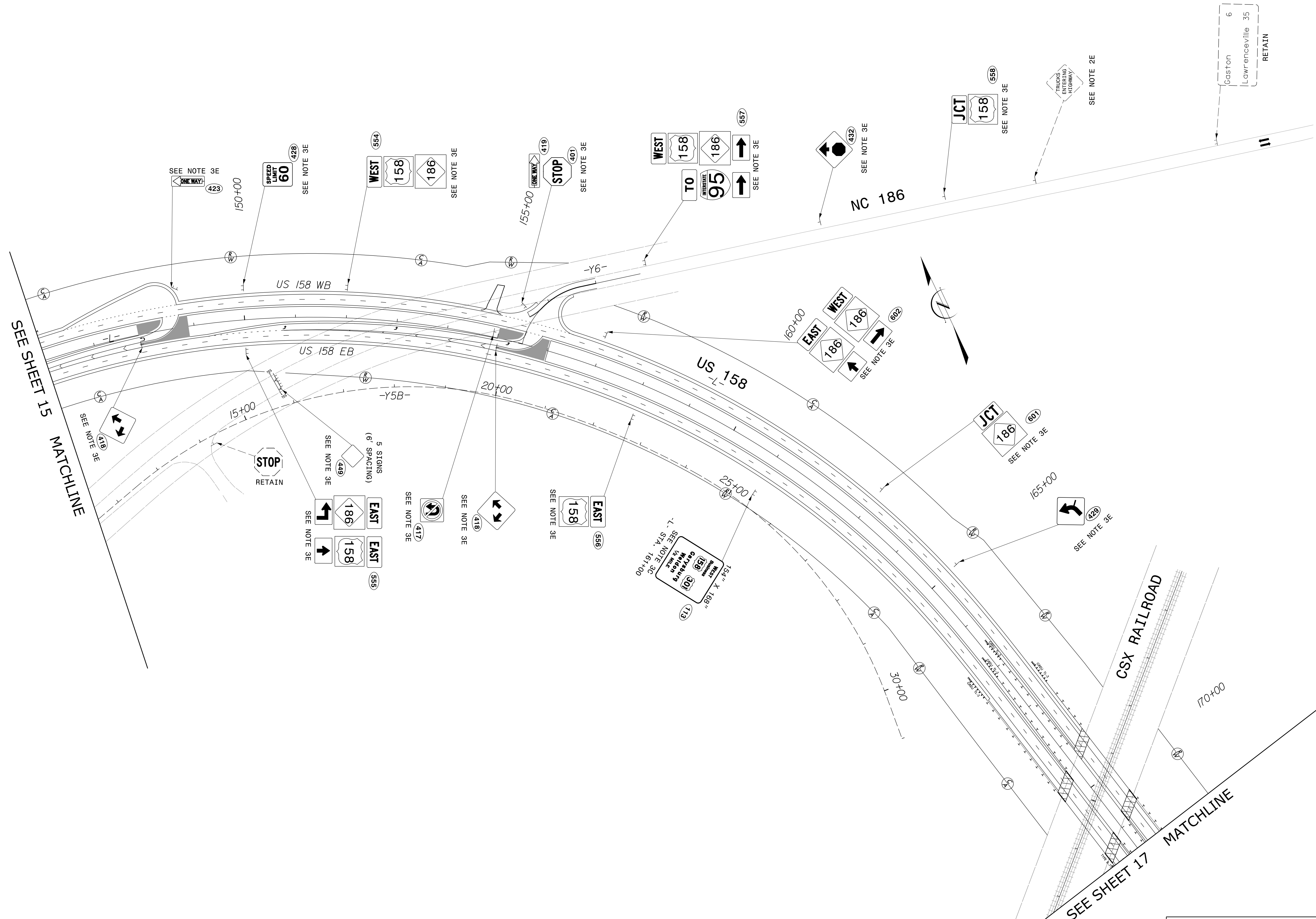
PROJECT REFERENCE NO. R-2582A	SHEET NO. SIGN-16
APPROVED: <i>Shadong Peng</i> <small>0886A0E5257455</small>	
DATE: 3/20/2019	
SEAL 	
DOCUMENT NOT CONSIDERED FINAL UNLESS ALL SIGNATURES COMPLETED	
<small>PREPARED IN THE OFFICE OF:</small>  Accelerate Engineering, PLLC 875 Walnut Street, Suite 316 Cary, NC 27511 Tel: 919.263.5678 Fax: 919.263.5687 NC License No. P-1442	

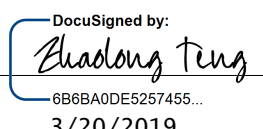

1
2
3
4
5
6
7
8
9
10
11
12
13
14
15
16
17
18
19
20
21
22
23
24
25
26
27
28
29
30
31
32
33
34
35
36
37
38
39
40
41
42
43
44
45
46
47
48
49
50
51
52
53
54
55
56
57
58
59
60
61
62
63
64
65
66
67
68
69
70
71
72
73
74
75
76
77
78
79
80
81
82
83
84
85
86
87
88
89
90
91
92
93
94
95
96
97
98
99
100

**EXISTING & PROPOSED SIGNS
-L- STA. 146+00 TO 171+50**

PROJECT REFERENCE NO. R-2582A	SHEET NO. SIGN-17
APPROVED:  0866A0DE5287455... 3/20/2019	
DATE: 3/20/2019	
SEAL 	
DOCUMENT NOT CONSIDERED FINAL UNLESS ALL SIGNATURES COMPLETED	
PREPARED IN THE OFFICE OF:  Accelerate Engineering, PLLC 875 Walnut Street, Suite 316 Cary, NC 27511 Tel: 919.263.5678 Fax: 919.263.5687 NC License No. P-1442	

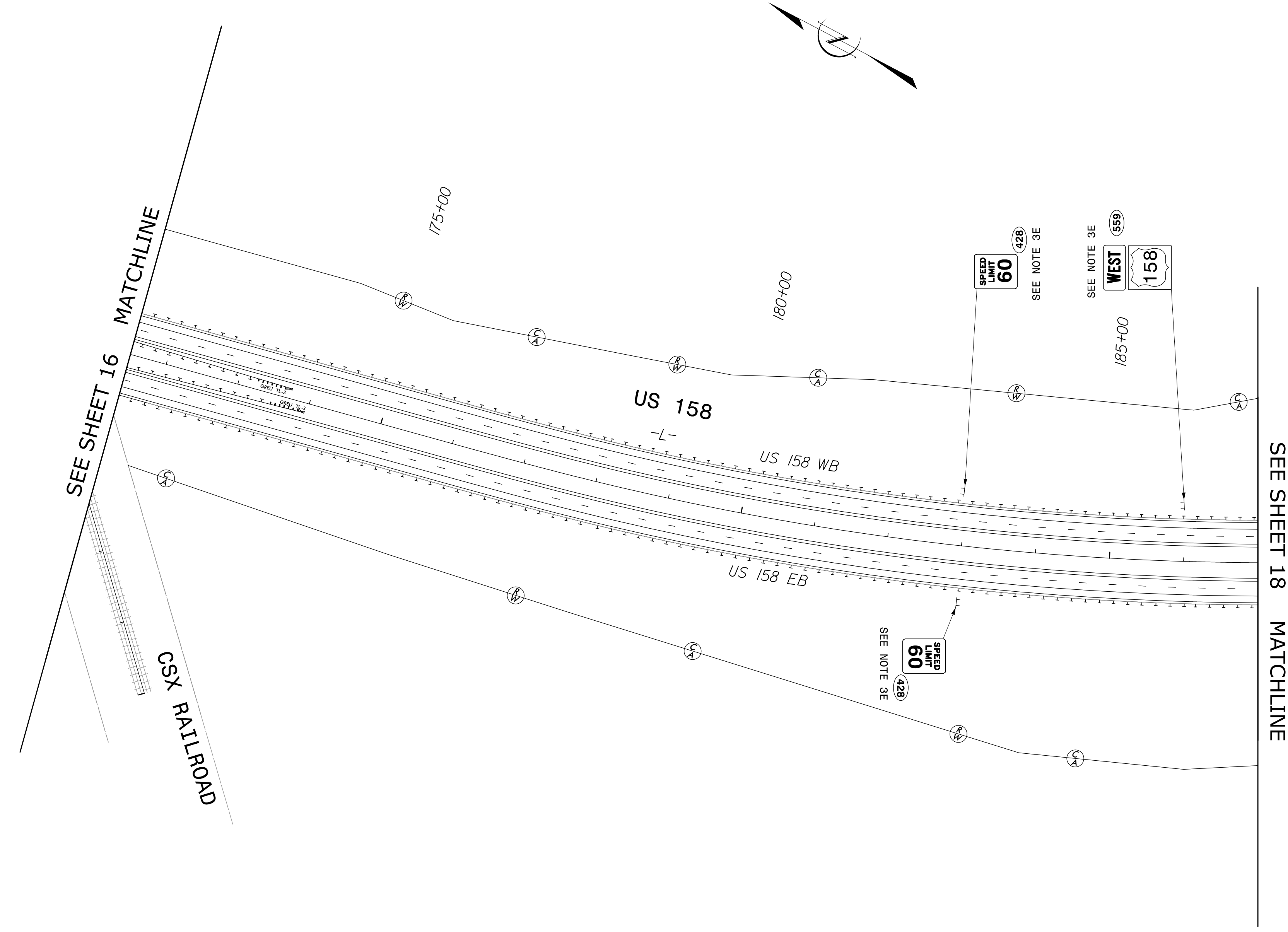

PROPOSED SIGNS
-L- STA. 171+50 TO 187+00

03/20/2019 10:58:11 AM

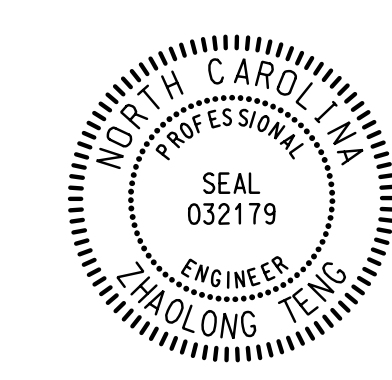
PROJECT REFERENCE NO. R-2582A	SHEET NO. SIGN-21
APPROVED: <i>Zhaolong Teng</i> 3/20/2019	
DATE: 3/20/2019	
SEAL 	
DOCUMENT NOT CONSIDERED FINAL UNLESS ALL SIGNATURES COMPLETED	
PREPARED IN THE OFFICE OF: Accelerate Engineering, PLLC 875 Walnut Street, Suite 316 Cary, NC 27511 Tel: 919.263.5678 Fax: 919.263.5687 NC License No. P-1442	



SEE SHEET 20 MATCHLINE

NOTE: RETAIN EXISTING SIGNS UNLESS OTHERWISE NOTED.

EXISTING & PROPOSED SIGNS GARYSBURG AREA

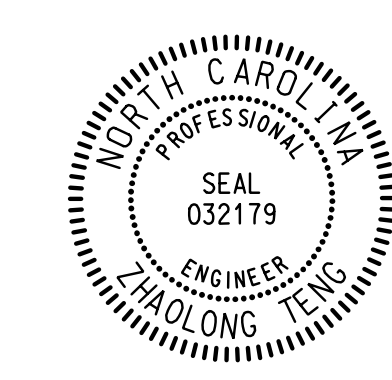

DATE PLOTTED: 3/20/2019 10:58 AM
SCALE: AS SHOWN
DRAWN BY: ZTENG
CHECKED BY: ZTENG
PROJECT: R-2582A
SHEET: SIGN-21

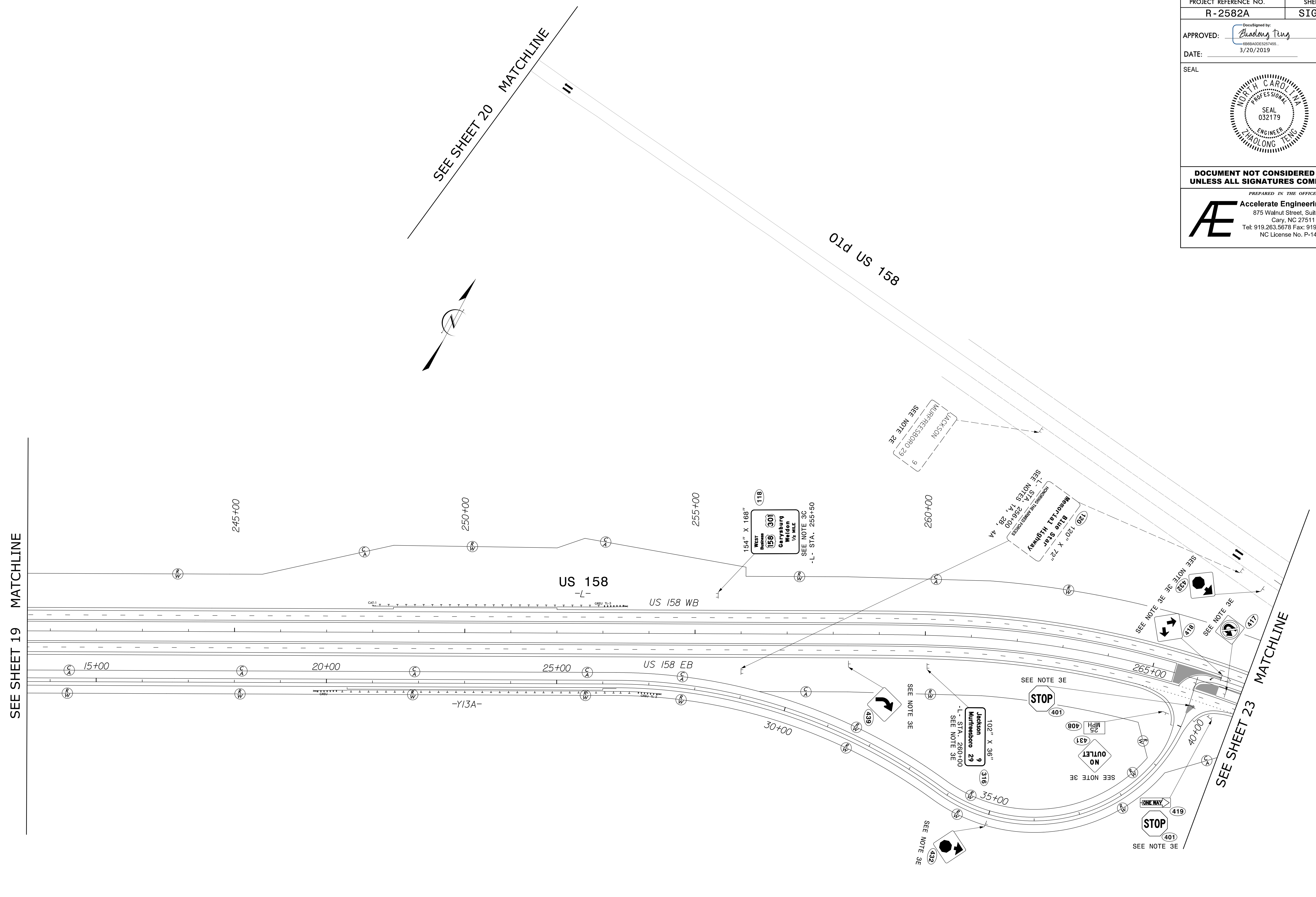
PROJECT REFERENCE NO. R-2582A	SHEET NO. SIGN-22
APPROVED: <i>Zhaolong Teng</i> 6668ADE5257455 3/20/2019	
DATE: 3/20/2019	
SEAL 	
DOCUMENT NOT CONSIDERED FINAL UNLESS ALL SIGNATURES COMPLETED	
PREPARED IN THE OFFICE OF: Accelerate Engineering, PLLC 875 Walnut Street, Suite 316 Cary, NC 27511 Tel: 919.263.5678 Fax: 919.263.5687 NC License No. P-1442	



**EXISTING & PROPOSED SIGNS
-L- STA. 240+50 TO 267+00**

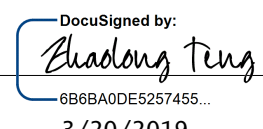

DATE PLOTTED: 3/20/2019 10:41:11 AM
 PLOTTER: HP DesignJet T1100
 PLOT SCALE: 1" = 400'

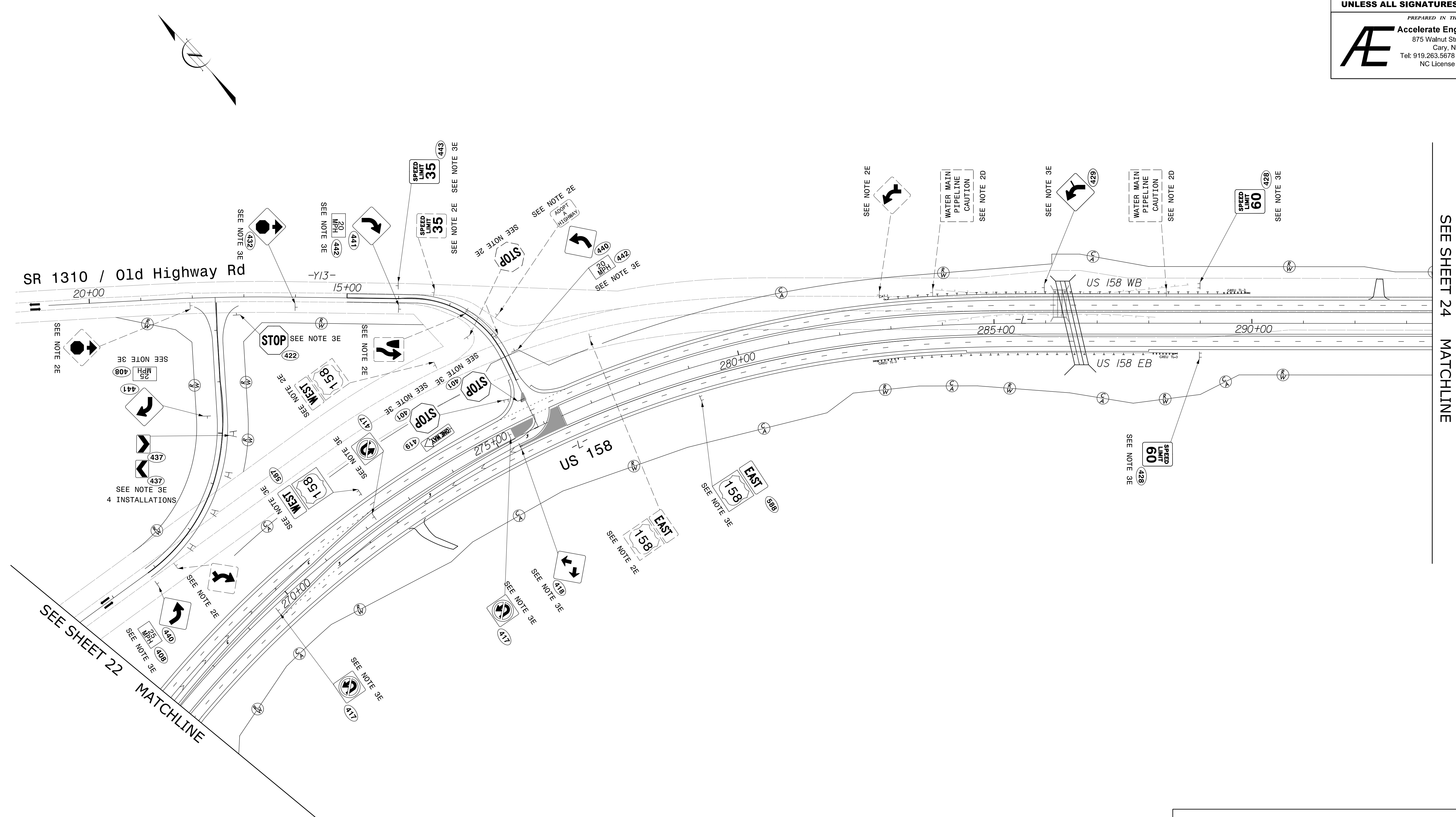
PROJECT REFERENCE NO. R-2582A	SHEET NO. SIGN-23
APPROVED:  6868A0DE5257455 3/20/2019	
DATE: 3/20/2019	
SEAL 	
DOCUMENT NOT CONSIDERED FINAL UNLESS ALL SIGNATURES COMPLETED	
PREPARED IN THE OFFICE OF:  Accelerate Engineering, PLLC 875 Walnut Street, Suite 316 Cary, NC 27511 Tel: 919.263.5678 Fax: 919.263.5687 NC License No. P-1442	

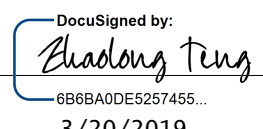
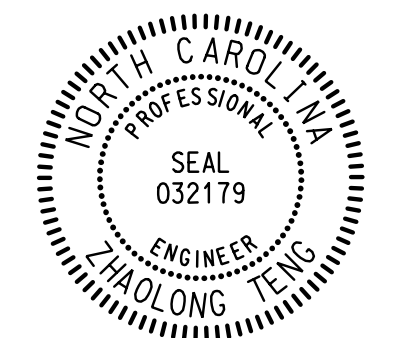

**EXISTING & PROPOSED SIGNS
-L- STA. 267+00 TO 293+50**

DATE PLOTTED: 3/20/2019 10:41:15 AM
PLOTTER: HP DesignJet T1100PS
PLOT SCALE: 1"=40'-0"

PROJECT REFERENCE NO. R-2582A	SHEET NO. SIGN-24
APPROVED:  6868A00E5257455	
DATE: 3/20/2019	
SEAL 	
DOCUMENT NOT CONSIDERED FINAL UNLESS ALL SIGNATURES COMPLETED	
PREPARED IN THE OFFICE OF:  Accelerate Engineering, PLLC 875 Walnut Street, Suite 316 Cary, NC 27511 Tel: 919.263.5678 Fax: 919.263.5687 NC License No. P-1442	

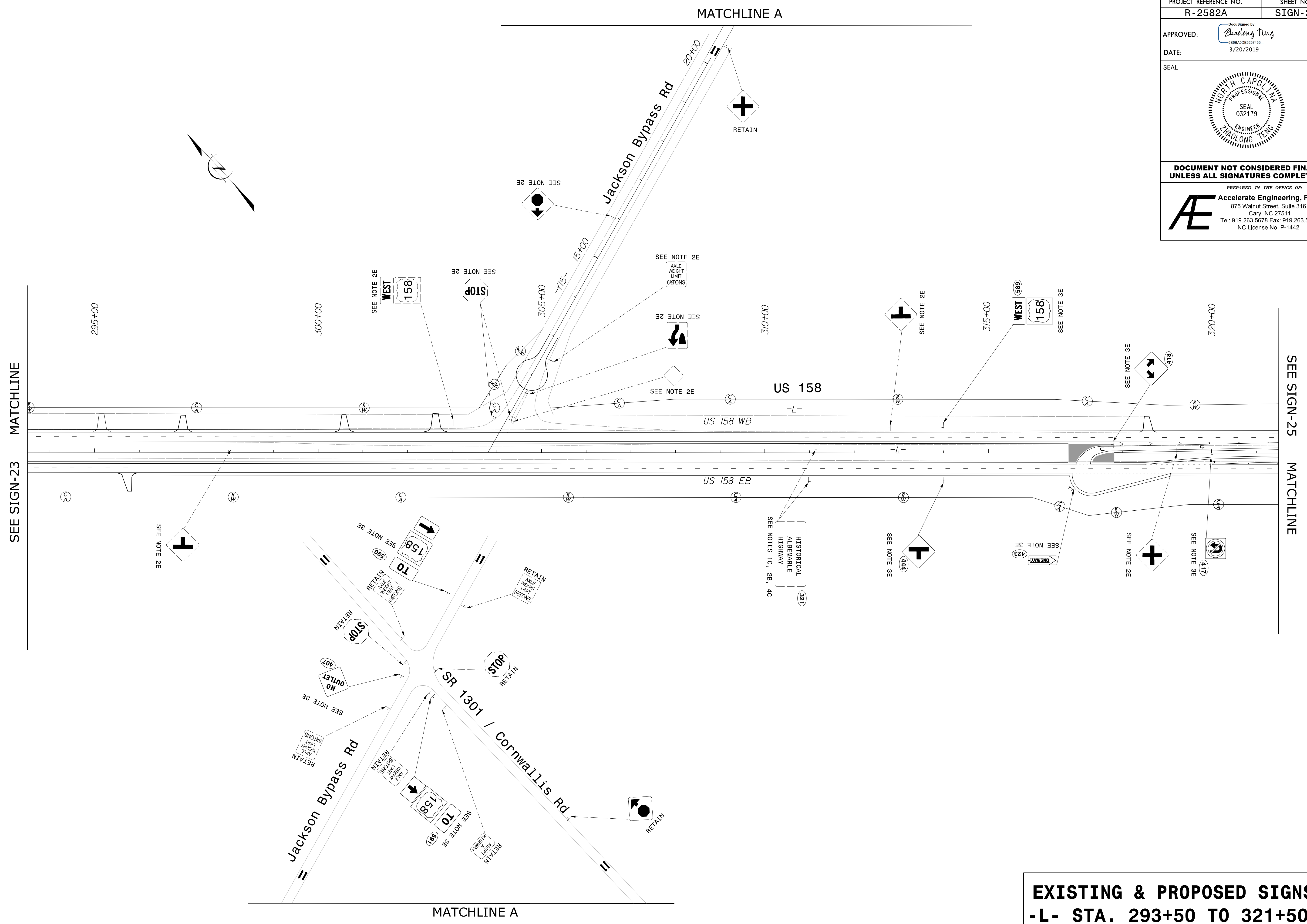

**EXISTING & PROPOSED SIGNS
-L- STA. 293+50 TO 321+50**

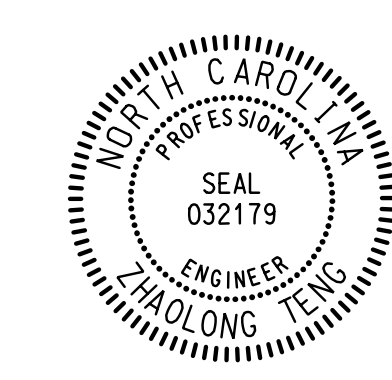

11/15/19 11:51 AM

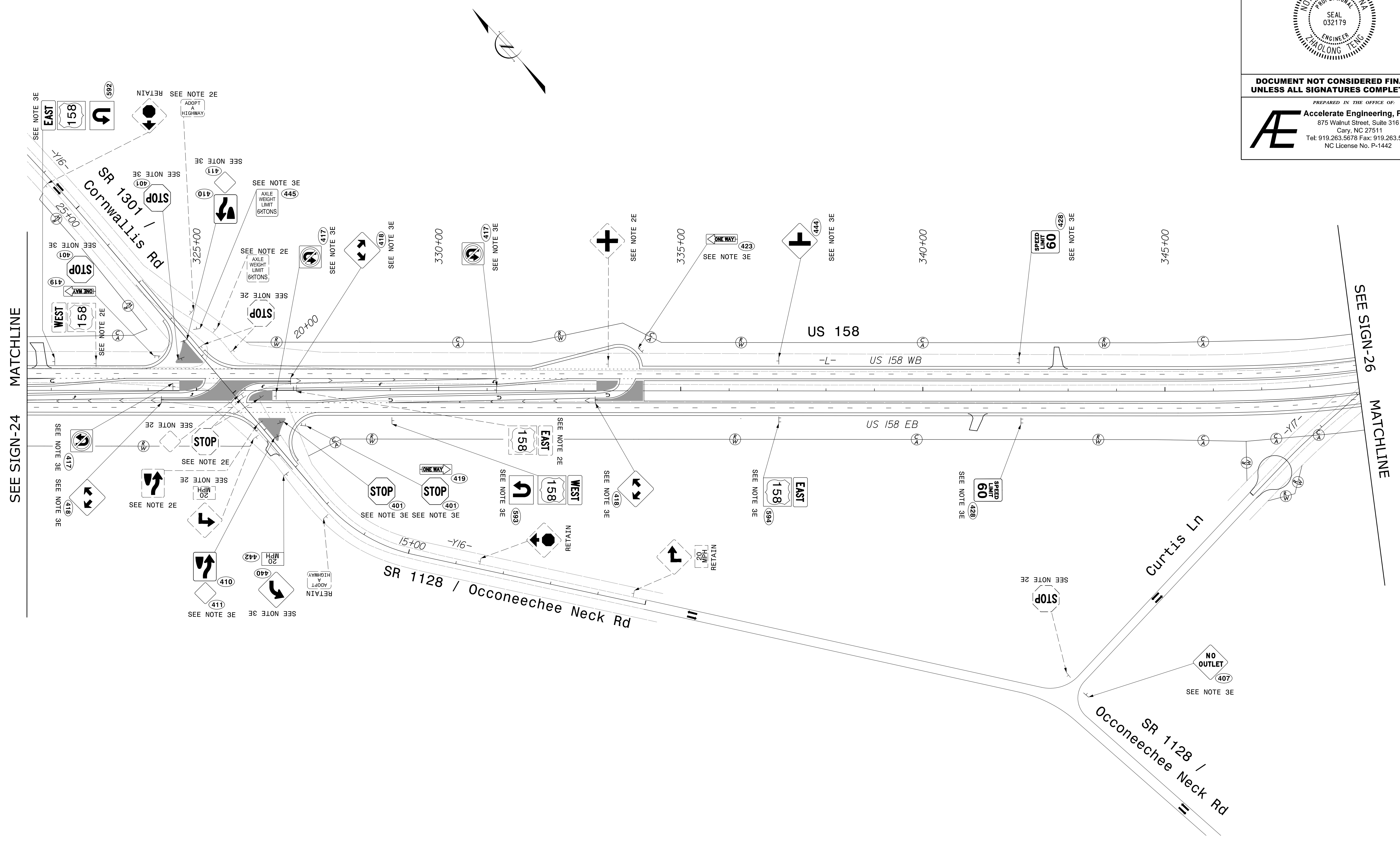
PROJECT REFERENCE NO. R-2582A	SHEET NO. SIGN-25
APPROVED: <i>Bradley Teng</i> 6866A0DE5257455 3/20/2019	
DATE: 3/20/2019	
SEAL 	
DOCUMENT NOT CONSIDERED FINAL UNLESS ALL SIGNATURES COMPLETED	
PREPARED IN THE OFFICE OF: Accelerate Engineering, PLLC 875 Walnut Street, Suite 316 Cary, NC 27511 Tel: 919.263.5678 Fax: 919.263.5687 NC License No. P-1442	

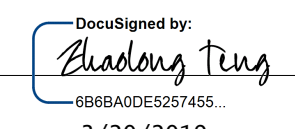
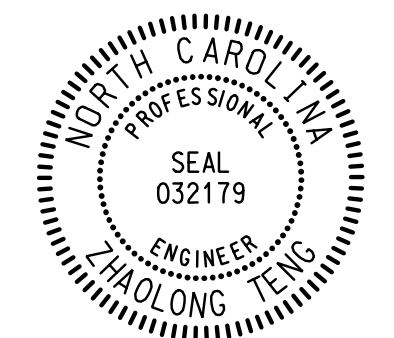

**EXISTING & PROPOSED SIGNS
-L- STA. 321+50 TO 349+00**

DATE PLOTTED: 3/20/2019 10:41:11 AM
 PLOTTER: HP DesignJet T1100
 PLOT SCALE: 1"=40'-0"

PROJECT REFERENCE NO. R-2582A	SHEET NO. SIGN-26
APPROVED:  3/20/2019	
DATE: 3/20/2019	
SEAL 	
DOCUMENT NOT CONSIDERED FINAL UNLESS ALL SIGNATURES COMPLETED	
PREPARED IN THE OFFICE OF:  Accelerate Engineering, PLLC 875 Walnut Street, Suite 316 Cary, NC 27511 Tel: 919.263.5678 Fax: 919.263.5687 NC License No. P-1442	

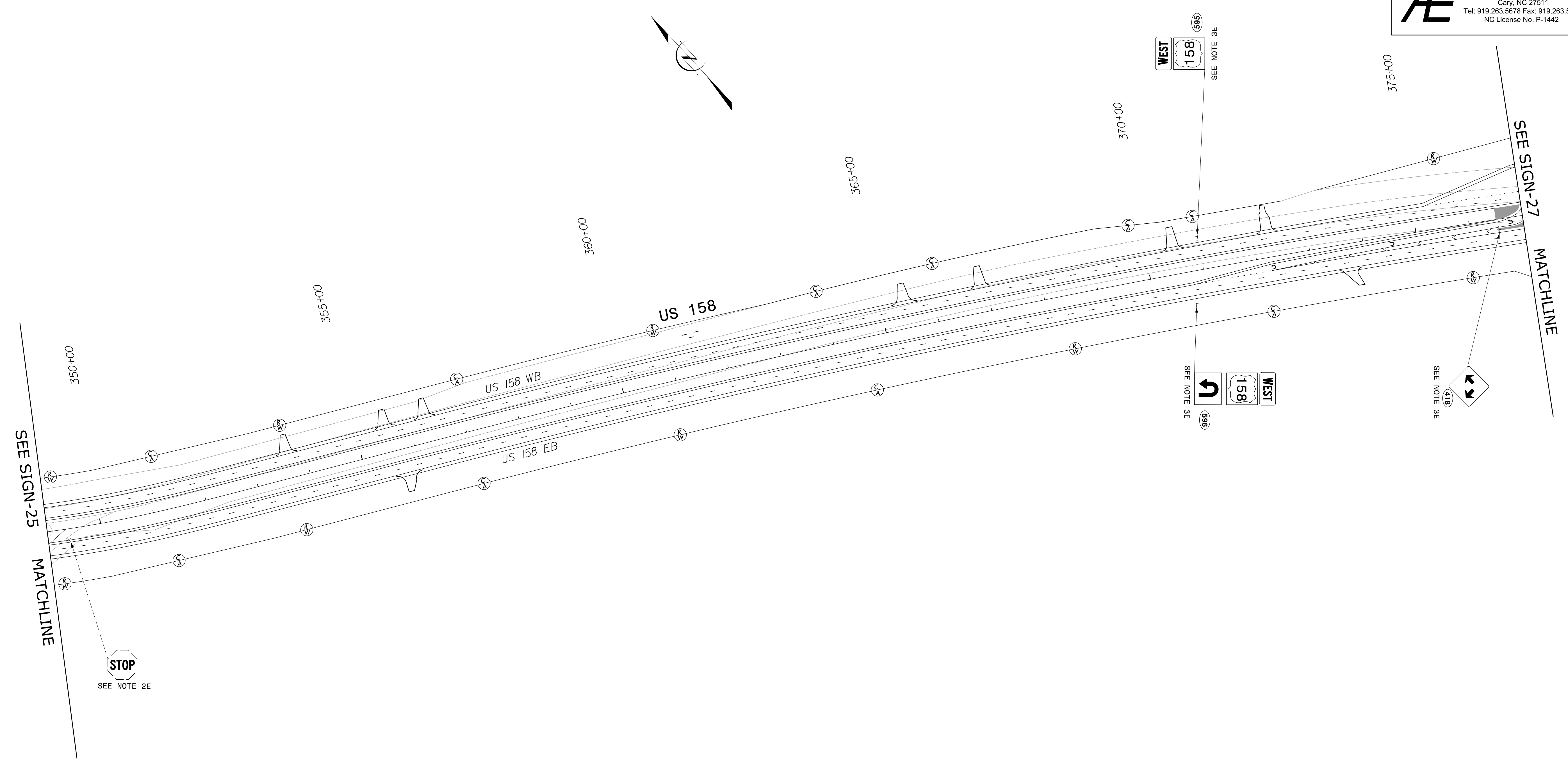

**EXISTING & PROPOSED SIGNS
-L- STA. 349+00 TO 377+00**

55
56
57
58
59
60
61
62
63
64
65
66
67
68
69
70
71
72
73
74
75
76
77
78
79
80
81
82
83
84
85
86
87
88
89
90
91
92
93
94
95
96
97
98
99
100

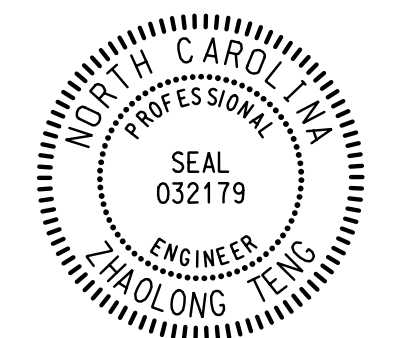
PROJECT REFERENCE NO. R-2582A	SHEET NO. SIGN-28
APPROVED: <i>Zhaolong Teng</i> 03/20/2019	
DATE: 3/20/2019	
SEAL 	
DOCUMENT NOT CONSIDERED FINAL UNLESS ALL SIGNATURES COMPLETED	
PREPARED IN THE OFFICE OF: Accelerate Engineering, PLLC 875 Walnut Street, Suite 316 Cary, NC 27511 Tel: 919.263.5678 Fax: 919.263.5687 NC License No. P-1442	

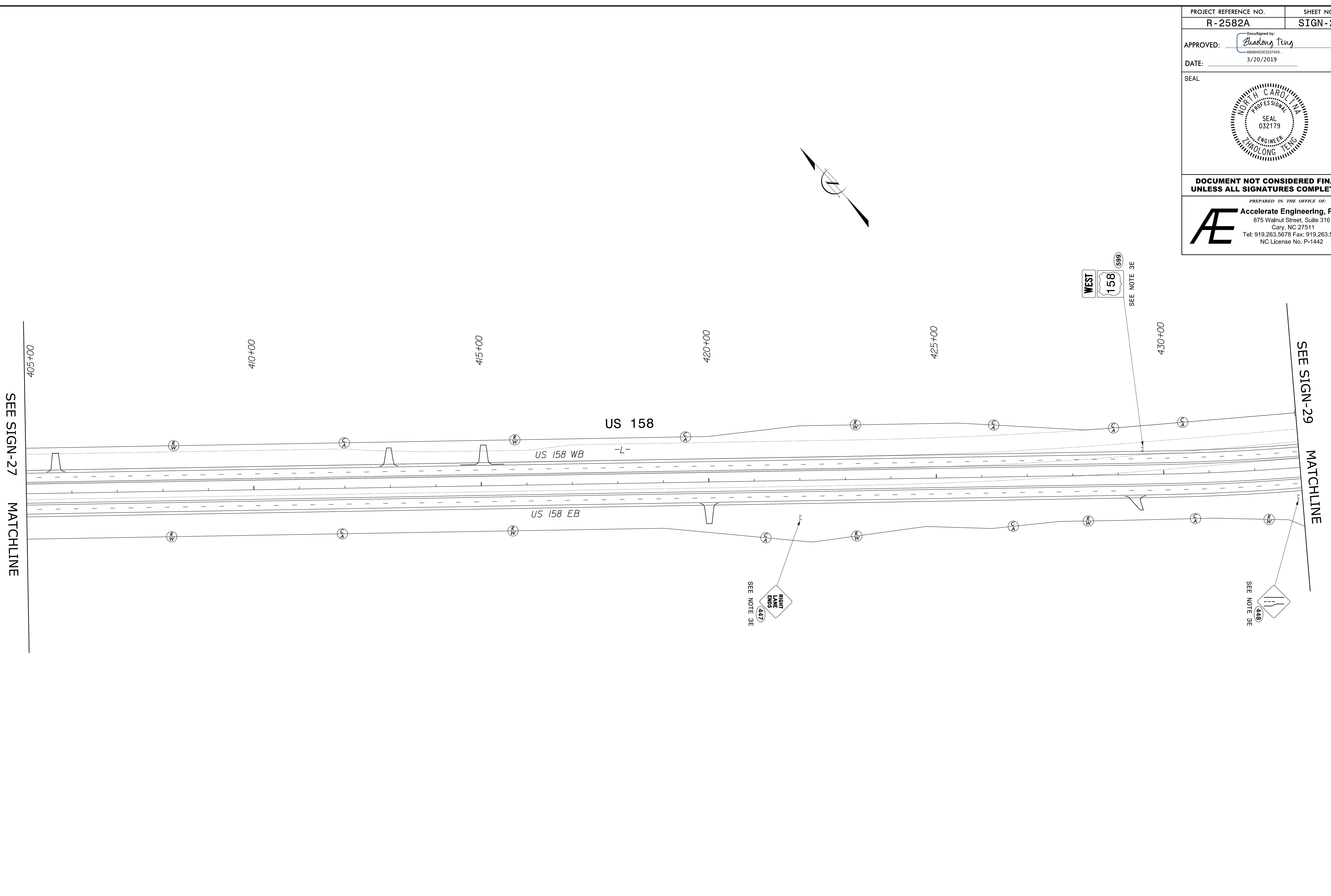

PROPOSED SIGNS
-L- STA. 405+00 TO 433+00

00
01
02
03
04
05
06
07
08
09
10
11
12
13
14
15
16
17
18
19
20
21
22
23
24
25
26
27
28
29
30
31
32
33
34
35
36
37
38
39
40
41
42
43
44
45
46
47
48
49
50
51
52
53
54
55
56
57
58
59
60
61
62
63
64
65
66
67
68
69
70
71
72
73
74
75
76
77
78
79
80
81
82
83
84
85
86
87
88
89
90
91
92
93
94
95
96
97
98
99

