

STATE OF NORTH CAROLINA
DIVISION OF HIGHWAYS

NORTHAMPTON COUNTY

**LOCATION: US 158 FROM I-95/NC 46 IN ROANOKE RAPIDS
TO SR 1312 (ST. JOHN CHURCH RD)**

**TYPE OF WORK: GRADING, DRAINAGE, PAVING, RESURFACING,
GUARDRAIL, SIGNALS, AND STRUCTURES.**

TIP NO. R-2582A SHEET NO. PMP-1

APPROVED: _____

DATE: _____

8/13/2020

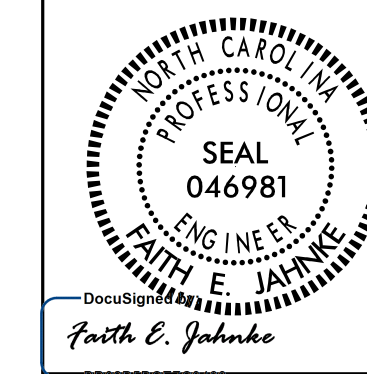

SEAL
NOT A CERTIFIED DOCUMENT AS TO THE ORIGINAL DOCUMENT BUT ONLY AS TO THE REVISIONS.
THIS DOCUMENT ORIGINALLY ISSUED AND SEALED BY:
J. STUART BOURNE
LIC. NO. 019680
ON
5/13/19
THIS DOCUMENT IS ONLY CERTIFIED AS TO THE REVISIONS.

DOCUMENT NOT CONSIDERED FINAL UNLESS ALL SIGNATURES COMPLETED

Prepared in the Office of: NC FIRM LICENSE No: P-0339
504 Meadowlands Drive Hillsborough, NC 27278
(919) 732-3883 (919) 732-6676 (FAX)

TIP PROJECT: R-2582A

CONTRACT: C204210

GENERAL NOTES

THE FOLLOWING GENERAL NOTES APPLY AT ALL TIMES FOR THE DURATION OF THE CONSTRUCTION PROJECT, EXCEPT WHEN OTHERWISE NOTED IN THE PLAN OR DIRECTED BY THE ENGINEER.

A) INSTALL PAVEMENT MARKINGS AND PAVEMENT MARKERS ON THE FINAL SURFACE AS FOLLOWS:

ROAD NAME	MARKING	MARKER
-L-	THERMO	SNOW PLOWABLE

B) TIE PROPOSED PAVEMENT MARKING LINES TO EXISTING PAVEMENT MARKING LINES.

C) REMOVE/REPLACE ANY CONFLICTING/DAMAGED PAVEMENT MARKINGS AND MARKERS.

US 158 /NC 46 MARKINGS

SYMBOL	DESCRIPTION	QUANTITY
THERMO (4", 90 MILS)		
T8	2 FT - 6 FT WHITE MINI-SKIP	965 LF
T9	2 FT - 6 FT YELLOW MINI-SKIP	145 LF
TA	WHITE EDGELINE	117,047 LF
TB	YELLOW EDGELINE	94,380 LF
TC	10 FT WHITE SKIP	20,730 LF
TD	3 FT - 9 FT/SP WHITE MINI SKIP	1,850 LF
TE	WHITE SOLID LANE LINE	845 LF
TF	10 FT. YELLOW SKIP	20 LF
TH	YELLOW SINGLE CENTER	68 LF
TI	YELLOW DOUBLE CENTER LINE	23,752 LF
THERMO (8", 90 MILS)		
T17	3 FT - 3 FT WHITE MINI-SKIP	238 LF
TN	WHITE GORELINE	17,800 LF
TO	WHITE DIAGONAL	1,395 LF
TP	YELLOW DIAGONAL	185 LF
TR	WHITE WIDE LANE LINE	100 LF
THERMO - PAVEMENT MARKING SYMBOLS (90 MILS)		
UA	LEFT ARROW	21 EA
UB	RIGHT ARROW	4 EA
UN	24" YIELD TRIANGLE	70 EA
UP	MERGE ARROW	15 EA
UT	U-TURN ARROW	27 EA
COLD APPLIED PLASTIC, TYPE I (4")		
CA	WHITE EDGELINE	984 LF
CB	YELLOW EDGELINE	984 LF
CC	10 FT WHITE SKIP	246 LF
CD	3 FT - 9 FT/SP WHITE MINI SKIP	182 LF
SNOWPLOWABLE PAVEMENT MARKERS		
ME	YELLOW & YELLOW	34 EA
MF	CRYSTAL & RED	2,204 EA

PAVEMENT MARKING SCHEDULE

SYMBOL	DESCRIPTION
THERMO (4", 90 MILS)	
T8	2 FT - 6 FT WHITE MINI-SKIP
T9	2 FT - 6 FT YELLOW MINI-SKIP
TA	WHITE EDGELINE
TB	YELLOW EDGELINE
TC	10 FT. WHITE SKIP
TD	3 FT - 9 FT/SP WHITE MINI SKIP
TE	WHITE SOLID LANE LINE
TF	10FT. YELLOW SKIP
TH	YELLOW SINGLE CENTER
TI	YELLOW DOUBLE CENTER LINE

THERMO (8", 90 MILS)	
T17	3 FT - 3 FT WHITE MINI-SKIP
TN	WHITE GORELINE
TO	WHITE DIAGONAL
TP	YELLOW DIAGONAL
TR	WHITE WIDE LANE LINE

THERMO - PAVEMENT MARKING SYMBOLS (90 MILS)	
UA	LEFT ARROW
UN	24" YIELD TRIANGLE
UP	MERGE ARROW
UT	U-TURN ARROW

COLD APPLIED PLASTIC (4")	
CA	WHITE EDGELINE
CB	YELLOW EDGELINE
CC	10 FT WHITE SKIP
CD	3 FT - 9 FT/SP WHITE MINI SKIP

ROADWAY STANDARD DRAWING

THE FOLLOWING ROADWAY STANDARDS AS APPEAR IN "ROADWAY STANDARD DRAWINGS" - PROJECT SERVICES UNIT - N.C. DEPARTMENT OF TRANSPORTATION - RALEIGH, N.C., DATED JANUARY 2018 ARE APPLICABLE TO THIS PROJECT AND BY REFERENCE HEREBY ARE CONSIDERED A PART OF THESE PLANS:

STD. NO.	TITLE
1205.01	PAVEMENT MARKINGS - LINE TYPES AND OFFSETS
1205.02	PAVEMENT MARKINGS - TWO-LANE AND MULTILANE ROADWAYS
1205.03	PAVEMENT MARKINGS - EXIT AND ENTRANCE RAMPS
1205.04	PAVEMENT MARKINGS - INTERSECTIONS
1205.05	PAVEMENT MARKINGS - TURN LANES
1205.06	PAVEMENT MARKINGS - LANE DROPS
1205.08	PAVEMENT MARKINGS - SYMBOLS AND WORD MESSAGES
1205.09	PAVEMENT MARKINGS - PAINTED ISLANDS
1205.12	PAVEMENT MARKINGS - BRIDGES
1205.13	PAVEMENT MARKINGS - LANE REDUCTIONS
1205.14	PAVEMENT MARKINGS - ROUNDABOUTS
1205.15	PAVEMENT MARKINGS - SUPERSTREETS
1250.01	RAISED PAVEMENT MARKERS - PAVEMENT MARKER SPACING
1253.01	RAISED PAVEMENT MARKERS - SNOWPLOWABLE
1261.01	GUARDRAIL & BARRIER DELINEATORS - INSTALLATION SPACING
1261.01	GUARDRAIL & BARRIER DELINEATORS - TYPES AND MOUNTING
1262.01	GUARDRAIL AND BARRIER DELINEATION - INSTALLATION SPACING

INDEX

PMP-1	PAVEMENT MARKING PLAN TITLE AND SCHEDULE SHEET
PMP-2-34	PAVEMENT MARKING DETAIL SHEETS

Prepared in the Office of:



NC FIRM LICENSE No: P-0339
504 Meadowlands Drive
Hillsborough, NC 27278
(919) 732-3883
(919) 732-6676 (FAX)

J. STUART BOURNE, PE PROJECT ENGINEER

NEIL ROHRBAUGH, EI PROJECT DESIGNER

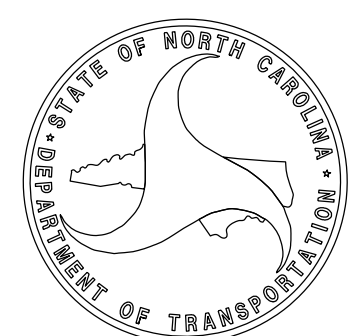

TIP NO. R-2582A	SHEET NO. PMP-2
APPROVED: <i>J. Stuart Bourne</i>	
DATE: 3/25/2019	
SEAL	
Prepared in the Office of: SUMMIT <small>ENGINEERING SERVICES</small>	
<small>NC FIRM LICENSE No. P-0239 504 Meadowlands Drive Hillsborough, NC 27278 (919) 732-3883 (919) 732-6676 (FAX)</small>	

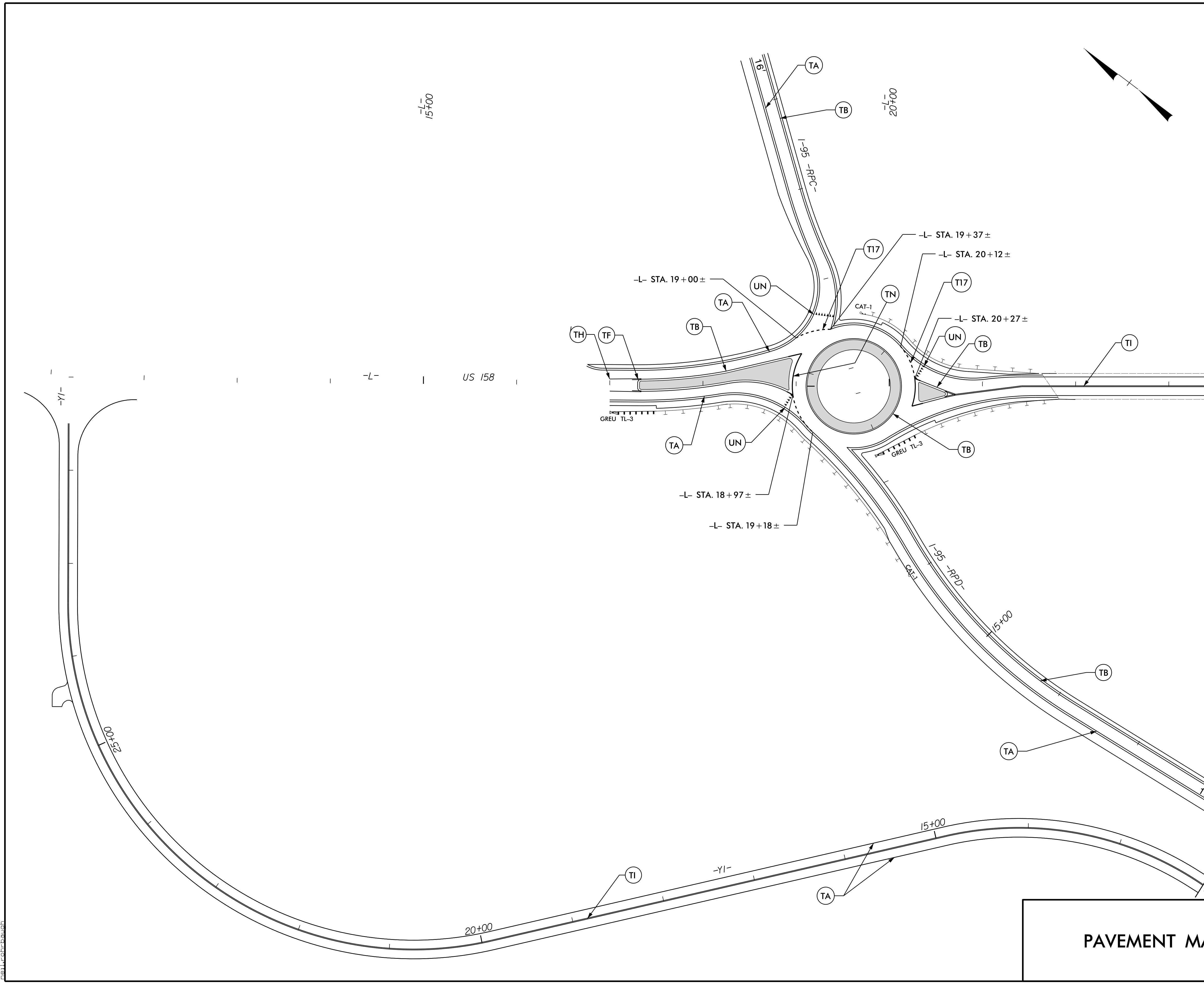
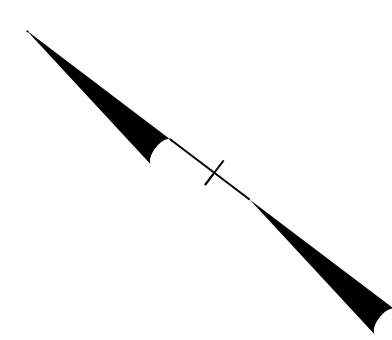

PAVEMENT MARKING DETAIL

20-MAR-2019 15:54
R-2582A-TIP-PMP-2.dgn
Hillsborough

TIP NO. R-2582A	SHEET NO. PMP-2A
APPROVED: <i>J. Stuart Bourne</i>	
DATE: 3/25/2019	
SEAL	
Prepared in the Office of: SUMMIT <small>ENGINEERING SERVICES</small>	
<small>NC FIRM LICENSE No. P-0239 504 Meadowlands Drive Hillsborough, NC 27278 (919) 732-3883 (919) 732-6676 (FAX)</small>	

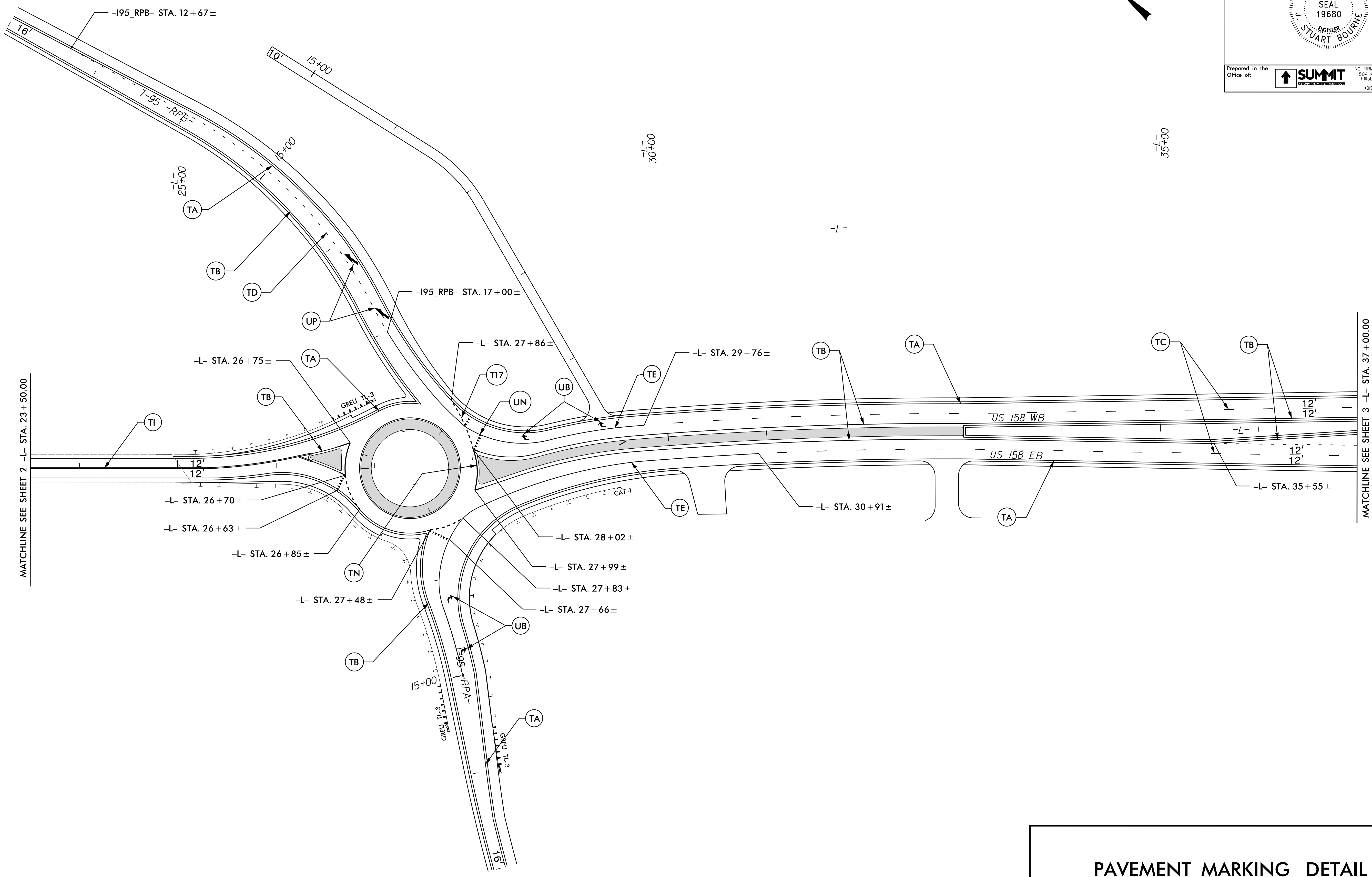
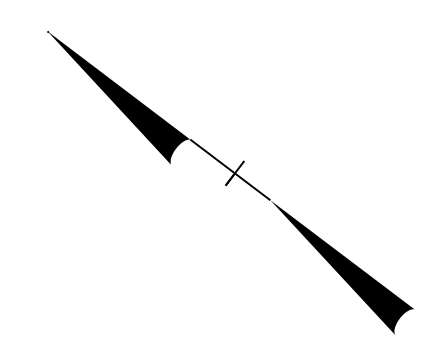

PAVEMENT MARKING DETAIL

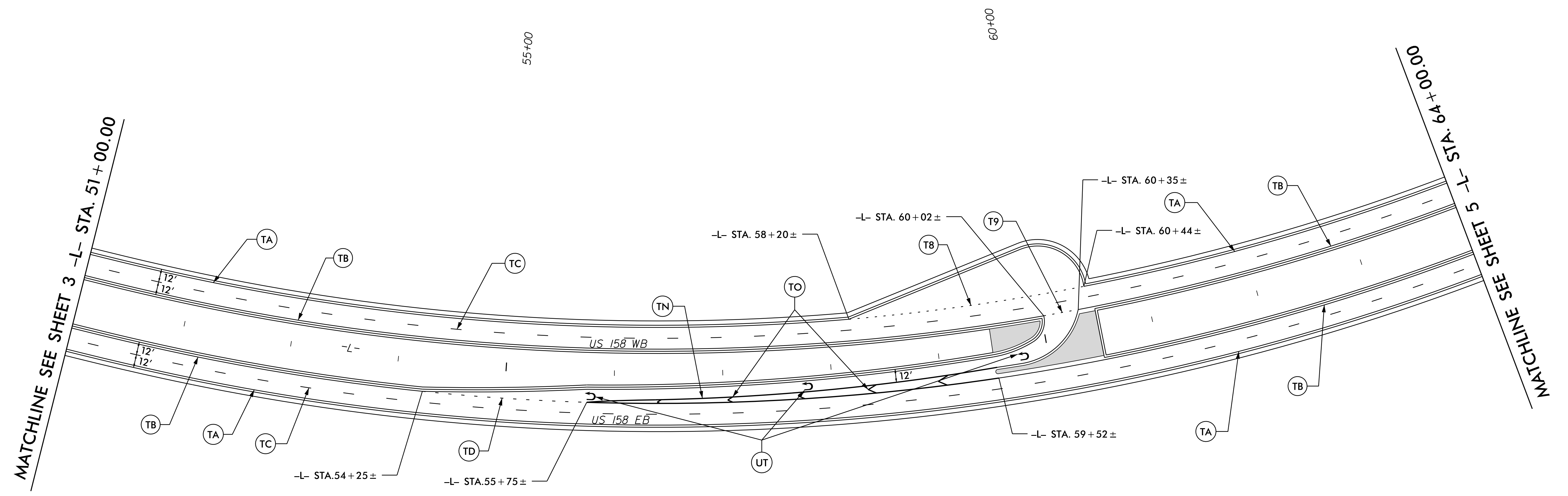
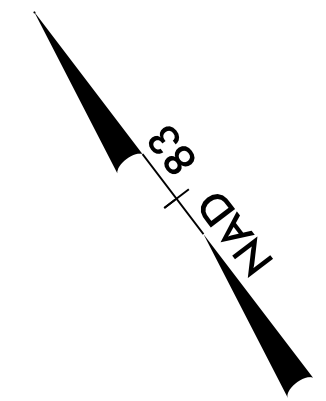

20_MAR_2019_15:55
 R-2582A_PMP-2A.dgn
 J. Stuart Bourne

TIP NO. R-2582A	SHEET NO. PMP-4
APPROVED: <i>J. Stuart Bourne</i> 287856C78F1248D...	
DATE: 3/25/2019	
SEAL	
Prepared in the Office of:	
	<small>NC FIRM LICENSE No. P-0239 504 Meadowlands Drive Hillsborough, NC 27278 (919) 732-3883 (919) 732-6676 (FAX)</small>

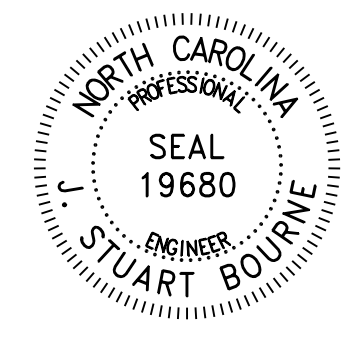

PAVEMENT MARKING DETAIL

20-MAR-2019 15:56
 R-2582A-TIP-FRM-4.dgn
 hillsborough

TIP NO. R-2582A	SHEET NO. PMP-5
APPROVED: <i>J. Stuart Bourne</i> <small>20170802/09/12/2019</small>	
DATE: 3/25/2019	
SEAL	
	
Prepared in the Office of:	 <small>NC FIRM LICENSE No. P-0239 504 Meadowslands Drive Hillsborough, NC 27278 (919) 732-3882 (919) 732-6676 (FAX)</small>

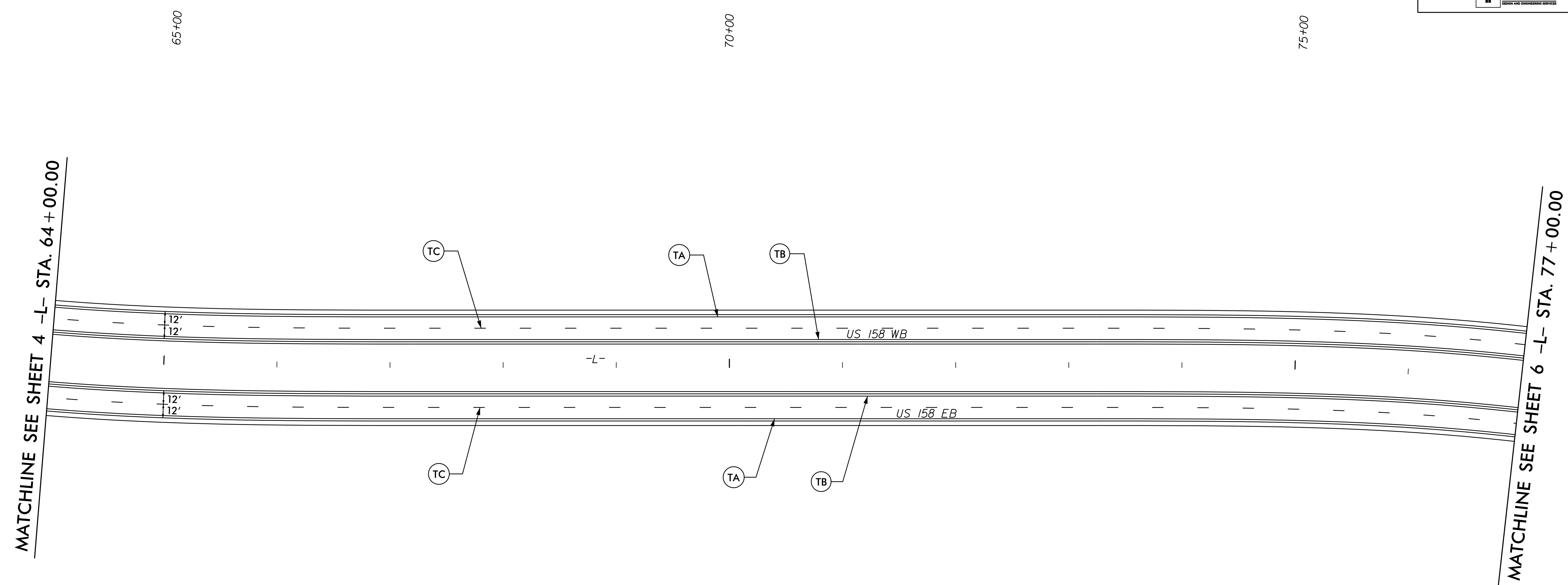
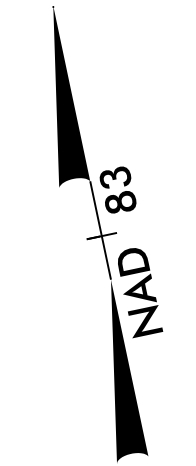

PAVEMENT MARKING DETAIL

20-MAR-2019 15:55
 R-2582A-TIP-PMP-5.dgn
 hillsborough

TIP NO. R-2582A	SHEET NO. PMP-6
APPROVED: <i>J. Stuart Bourne</i>	
DATE: 3/25/2019	
SEAL	
Prepared in the Office of:	
	<small>NC FIRM LICENSE No. P-0239 504 Meadowlands Drive Hillsborough, NC 27278 (919) 732-3883 (919) 732-6676 (FAX)</small>

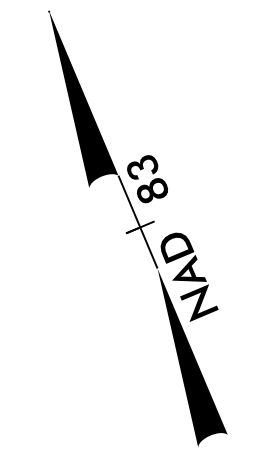

MATCHLINE SEE SHEET 5 -L- STA. 77 + 00.00

MATCHLINE SEE SHEET 7 -L- STA. 90 + 50.00

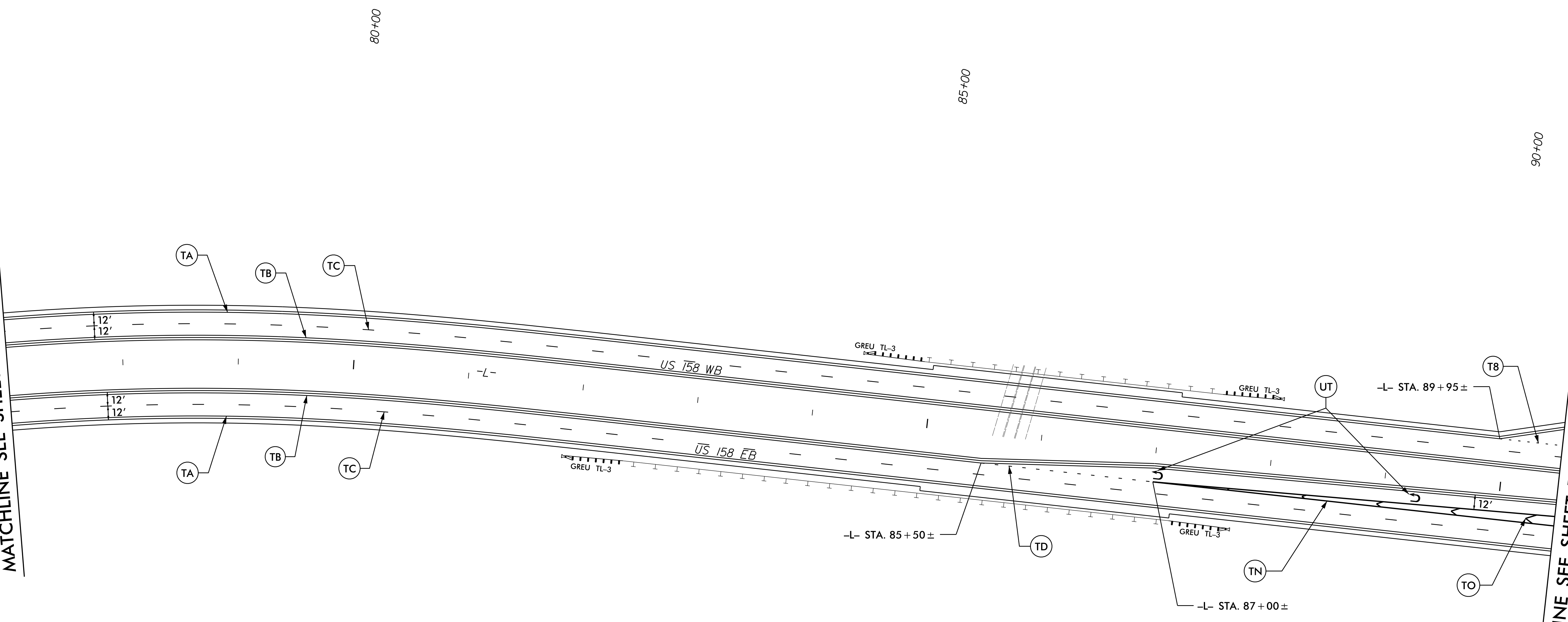

PAVEMENT MARKING DETAIL

TIP NO. R-2582A	SHEET NO. PMP-7
APPROVED: <i>J. Stuart Bourne</i>	
DATE: 3/25/2019	
SEAL	
Prepared in the Office of:	
	<small>NC FIRM LICENSE No. P-0239 504 Meadowlands Drive Hillsborough, NC 27278 (919) 732-3883 (919) 732-6676 (FAX)</small>

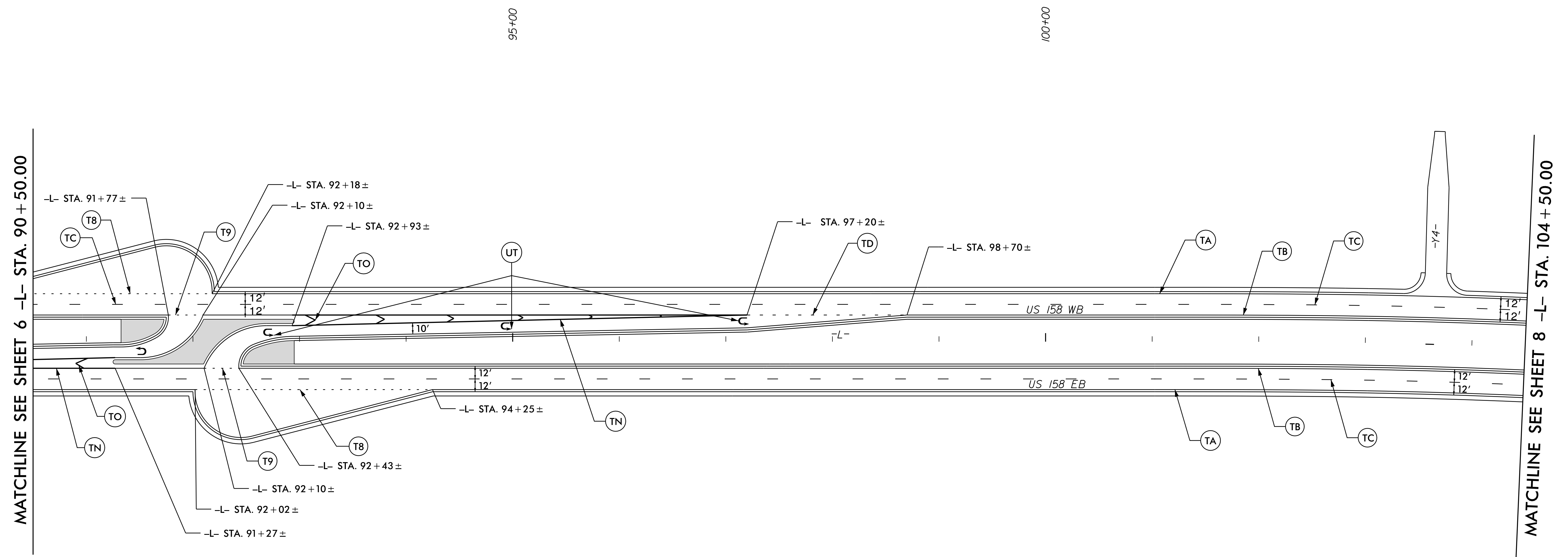
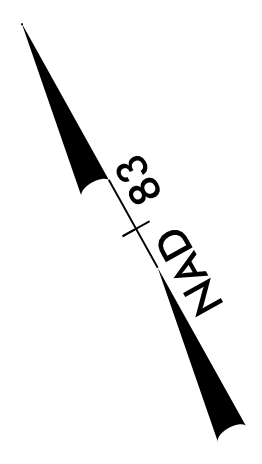

PAVEMENT MARKING DETAIL

20-MAR-2019 15:57
 R-2582A-TIP-PMP-7.dgn
 jstuartbourne

TIP NO. R-2582A	SHEET NO. PMP-8
APPROVED: <i>J. Stuart Bourne</i> DATE: 3/25/2019	
SEAL	
Prepared in the Office of: SUMMIT <small>ROAD AND CONSTRUCTION SERVICES</small>	
<small>NC FIRM LICENSE No. P-0239 504 Meadowlands Drive Hillsborough, NC 27278 (919) 732-3883 (919) 732-6676 (FAX)</small>	

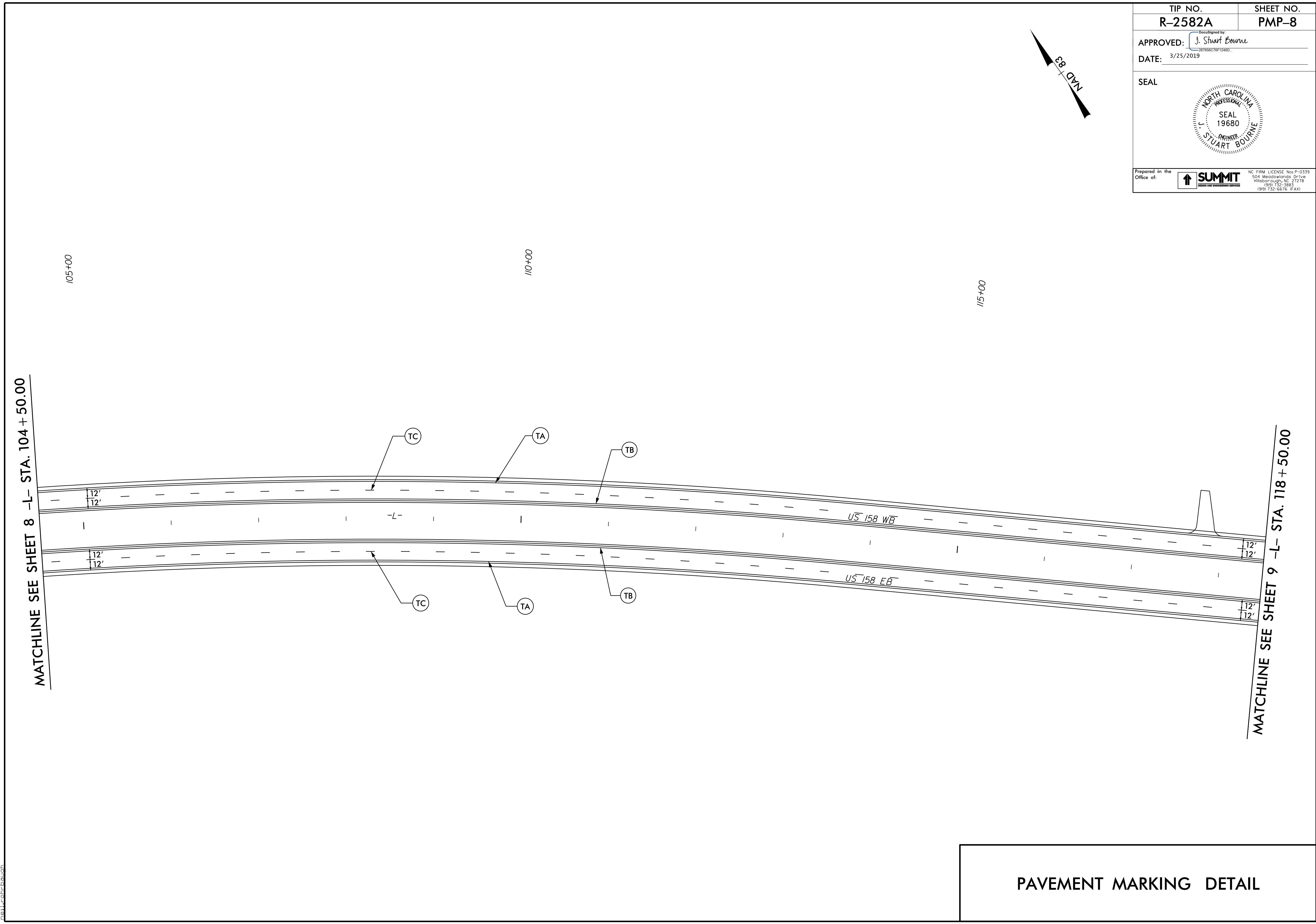
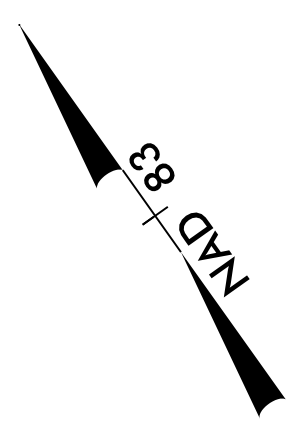

PAVEMENT MARKING DETAIL

20-MAR-2019 15:58
 R-2582A-TIP-FRM-8.dgn
 hillsborough

TIP NO. R-2582A	SHEET NO. PMP-9
APPROVED: <i>J. Stuart Bourne</i> DATE: 3/25/2019	
SEAL	
Prepared in the Office of: SUMMIT <small>ENGINEERING SERVICES</small>	
<small>NC FIRM LICENSE No. P-0239 504 Meadowlands Drive Hillsborough, NC 27278 (919) 732-3883 (919) 732-6676 (FAX)</small>	

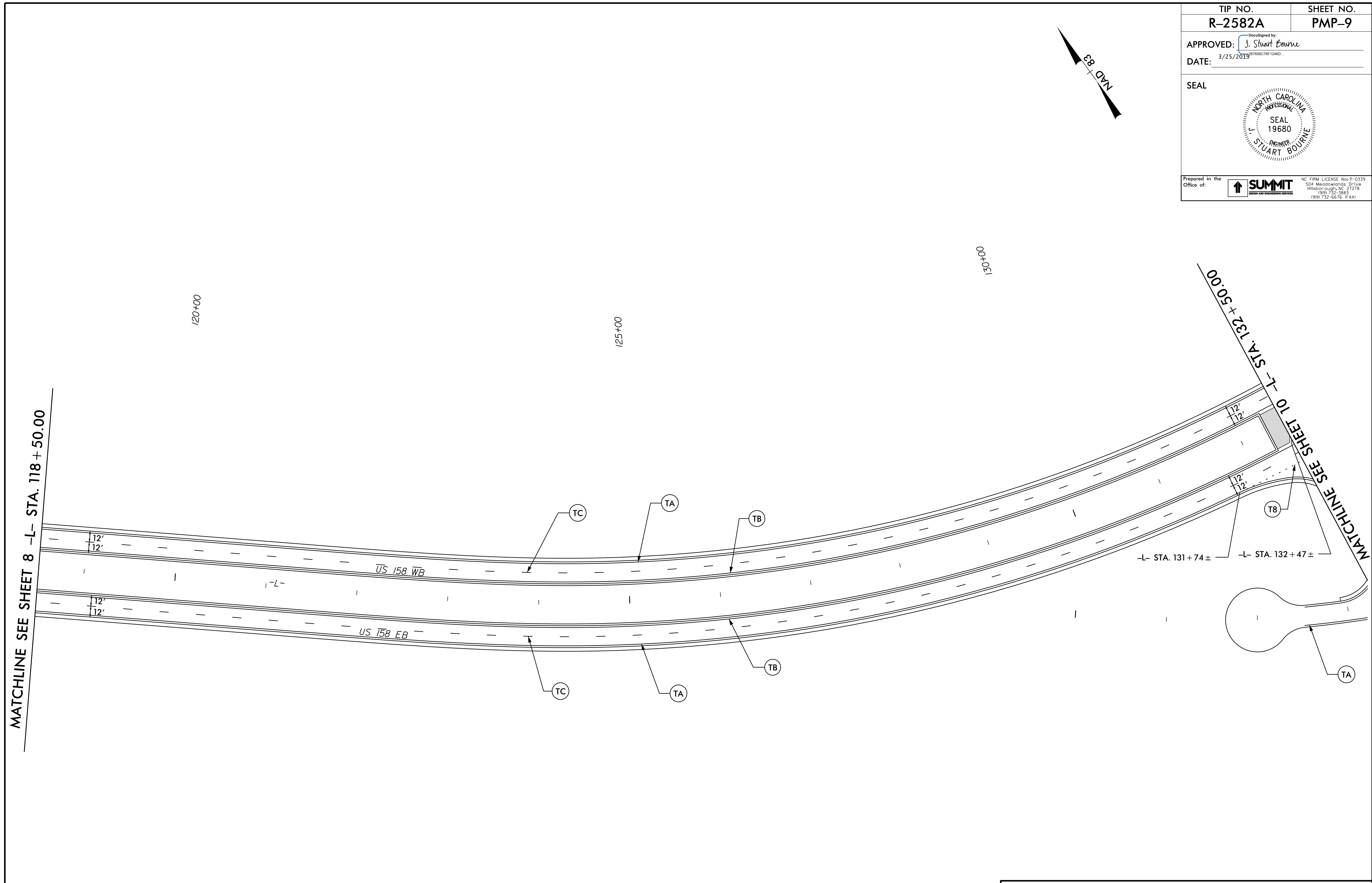
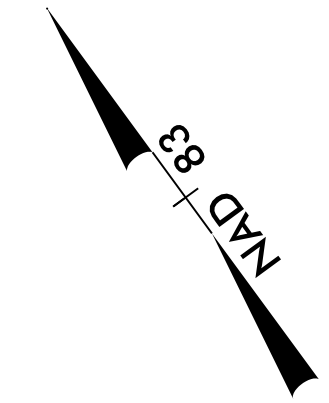

20-MAR-2019 15:58
 R-2582A-TIP-PMP-9.dgn
 hillsborough

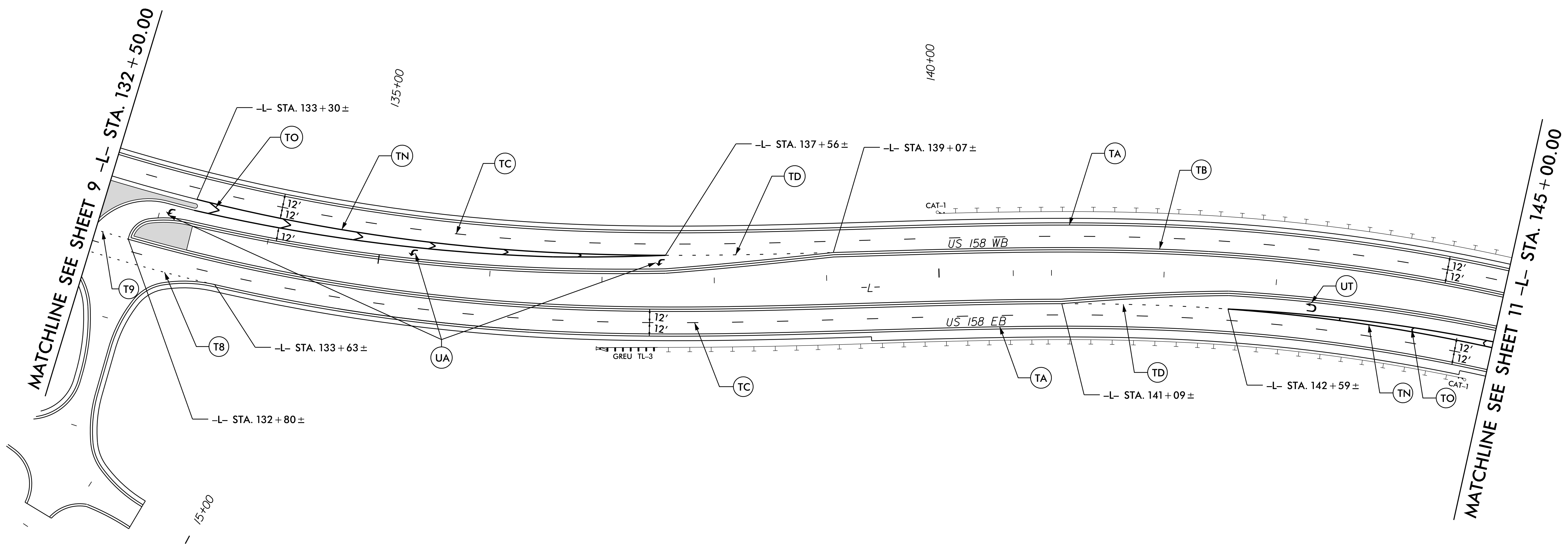
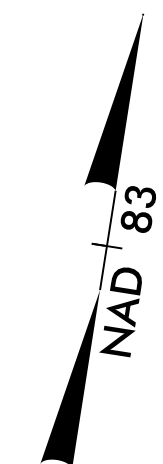

PAVEMENT MARKING DETAIL

TIP NO. R-2582A	SHEET NO. PMP-10
APPROVED: <i>J. Stuart Bourne</i>	
DATE: 3/25/2019	
SEAL	
Prepared in the Office of: SUMMIT <small>ROAD AND CONSTRUCTION SERVICES</small>	
<small>NC FIRM LICENSE No. P-0239 504 Meadowlands Drive Hillsborough, NC 27278 (919) 732-3983 (919) 732-6676 (FAX)</small>	

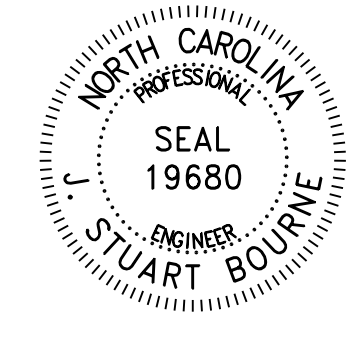

PAVEMENT MARKING DETAIL

20-MAR-2019 15:58
 R-2582A-TIP-PMP-10.dgn
 Hillsborough

TIP NO. R-2582A	SHEET NO. PMP-11
APPROVED: <i>J. Stuart Bourne</i>	
DATE: 3/25/2019	
SEAL	
	
Prepared in the Office of:  SUMMIT <small>ROAD AND CONSTRUCTION SERVICES</small>	
<small>NC FIRM LICENSE No. P-0239 504 Meadowlands Drive Hillsborough, NC 27278 (919) 732-3883 (919) 732-6676 (FAX)</small>	

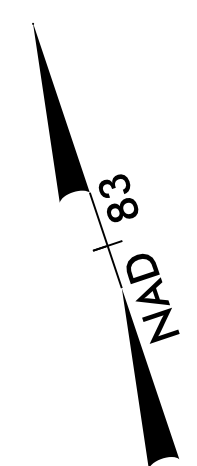

145+00

150+00

155+00

MATCHLINE SEE SHEET 10 -L- STA. 145+00.00

MATCHLINE SEE SHEET 12 -L- STA. 158+00.00

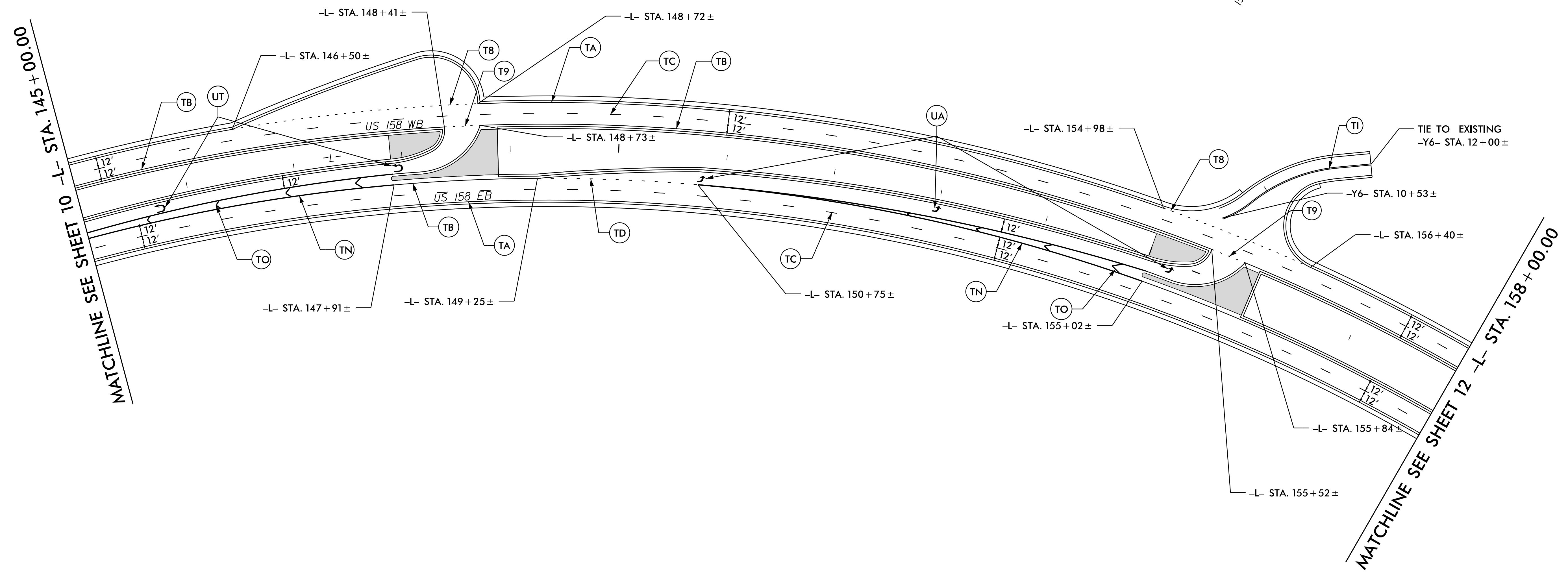

PAVEMENT MARKING DETAIL

20-MAR-2019 15:59
 R-2582A-TIP-FRM-11.dgn
 hillsborough

TIP NO. R-2582A	SHEET NO. PMP-12
APPROVED: <i>J. Stuart Bourne</i>	
DATE: 3/25/2019	
SEAL	
Prepared in the Office of: SUMMIT <small>ROAD AND CONSTRUCTION SERVICES</small>	
<small>NC FIRM LICENSE No. P-0239 504 Meadowlands Drive Hillsborough, NC 27278 (919) 732-3883 (919) 732-6676 (FAX)</small>	

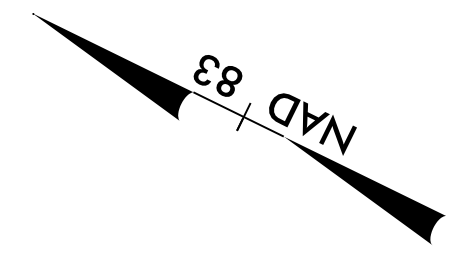

MATCHLINE SEE SHEET 11 -L- STA. 158 + 00.00

MATCHLINE SEE SHEET 13 -L- STA. 171 + 50.00

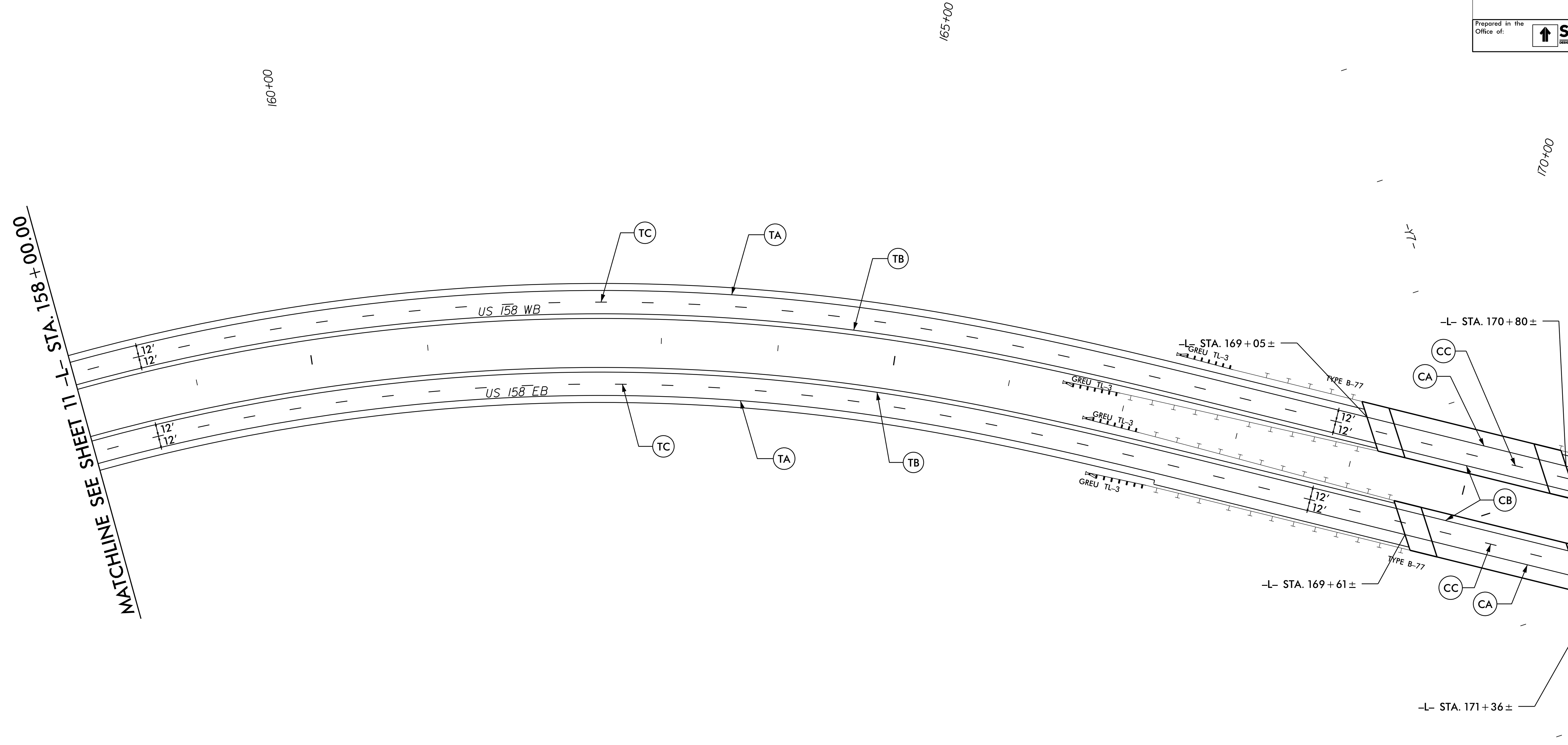

PAVEMENT MARKING DETAIL

20 MAR 2019 16:00
 R-2582A PMP-12.dgn
 J. Stuart Bourne

TIP NO. R-2582A	SHEET NO. PMP-14
APPROVED: <i>J. Stuart Bourne</i>	
DATE: 3/25/2013	
SEAL	
Prepared in the Office of: SUMMIT <small>ROAD AND CONSTRUCTION SERVICES</small>	
<small>NC FIRM LICENSE No. P-0239 504 Meadowslands Drive Hillsborough, NC 27278 (919) 732-3883 (919) 732-6676 (FAX)</small>	

SEE SHEET 14A

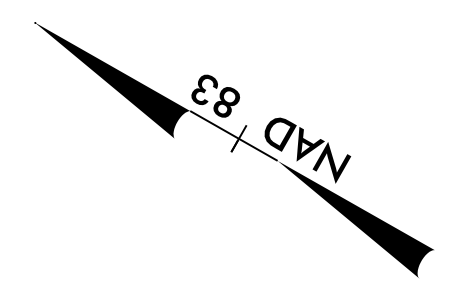
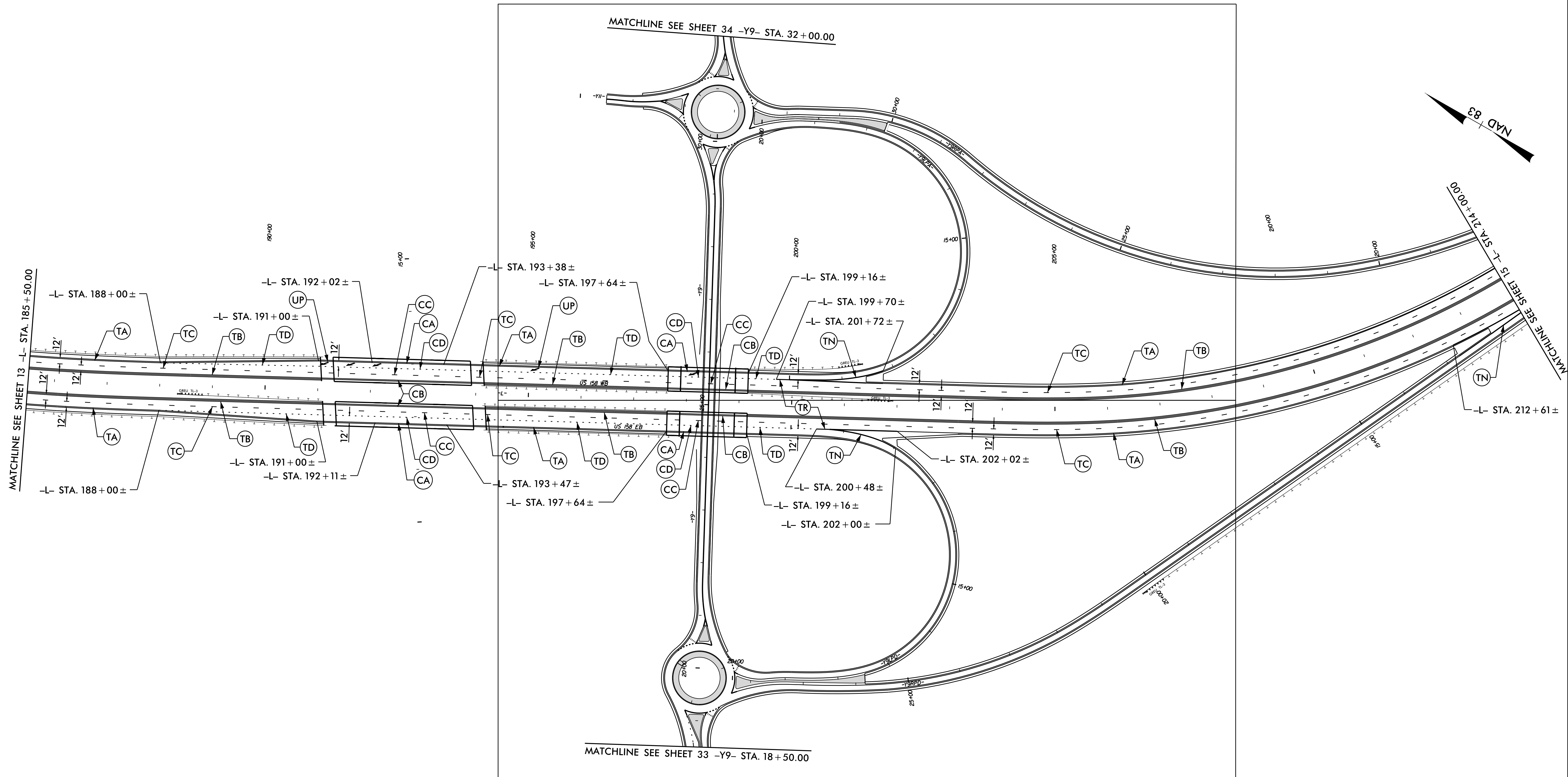

SEE SHEET 14B

PAVEMENT MARKING DETAIL

20-MAR-2013 16:01
R-2582A-TIP-PMP-14.dgn
J. Stuart Bourne

TIP NO. R-2582A	SHEET NO. PMP-14A
APPROVED: <i>J. Stuart Bourne</i>	
DATE: 3/25/2019	
SEAL	
Prepared in the Office of: SUMMIT <small>ROAD AND CONSTRUCTION SERVICES</small>	
<small>NC FIRM LICENSE No. P-0239 504 Meadowlands Drive Hillsborough, NC 27278 (919) 732-3883 (919) 732-6676 (FAX)</small>	

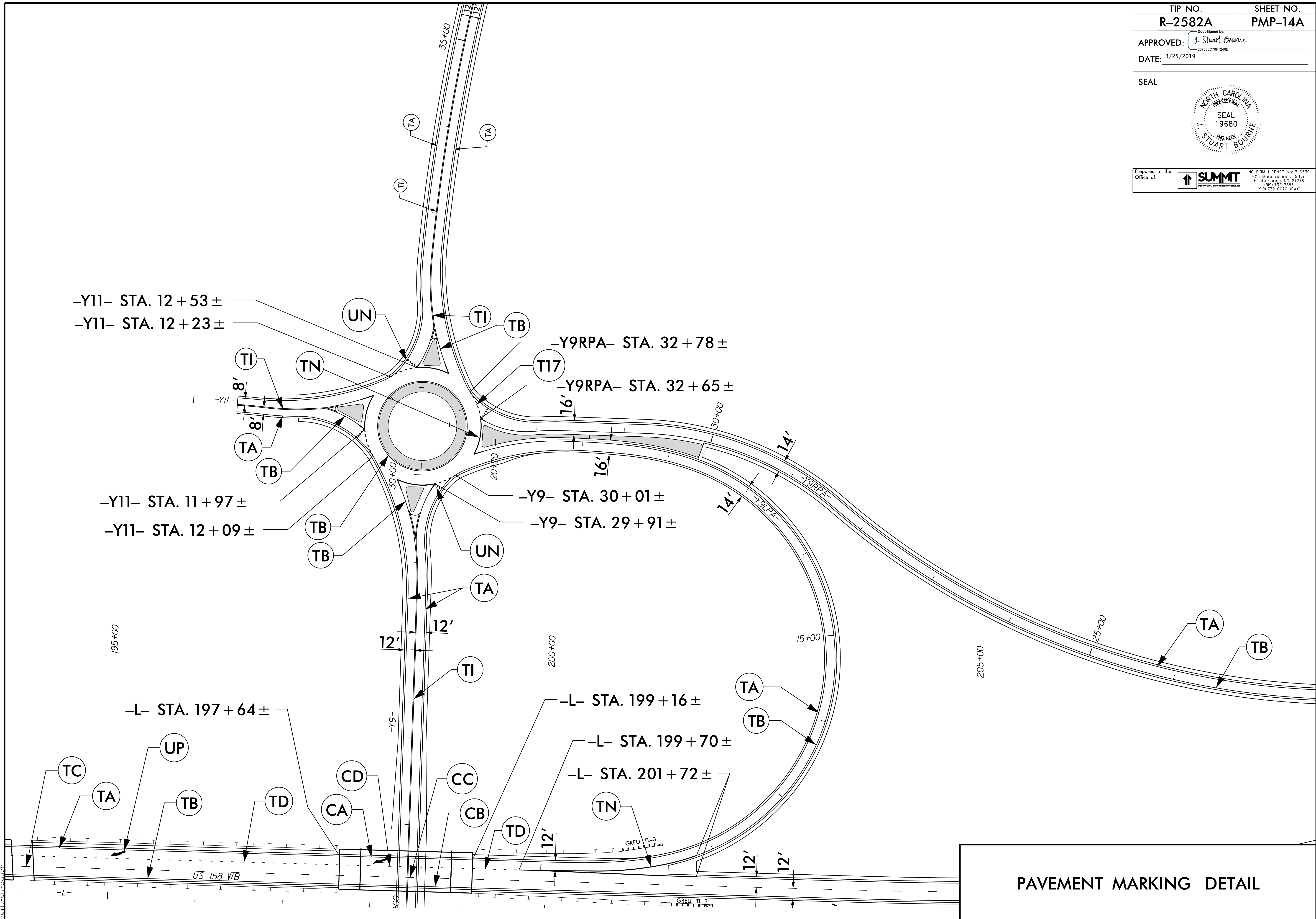

PAVEMENT MARKING DETAIL

20-MAR-2019 16:02
 R-2582A-PMP-14A.dgn
 jstuart@summiteng.com

TIP NO. R-2582A	SHEET NO. PMP-14B
APPROVED: <i>J. Stuart Bourne</i>	
DATE: 3/25/2013	
SEAL	
Prepared in the Office of:	
<small>NC FIRM LICENSE No. P-0239 504 Meadowlands Drive Hillsborough, NC 27278 (919) 732-3883 (919) 732-6676 (FAX)</small>	

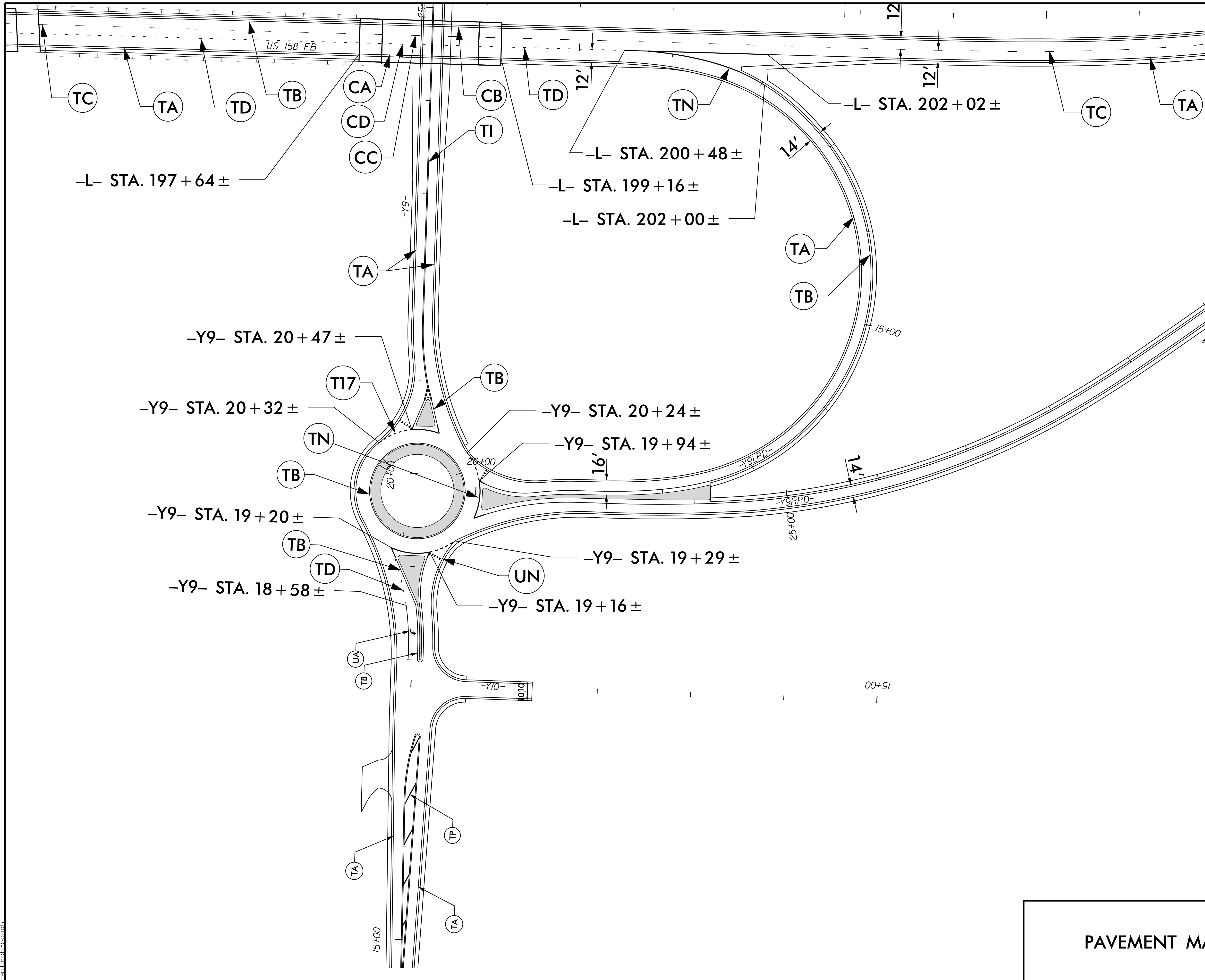

PAVEMENT MARKING DETAIL

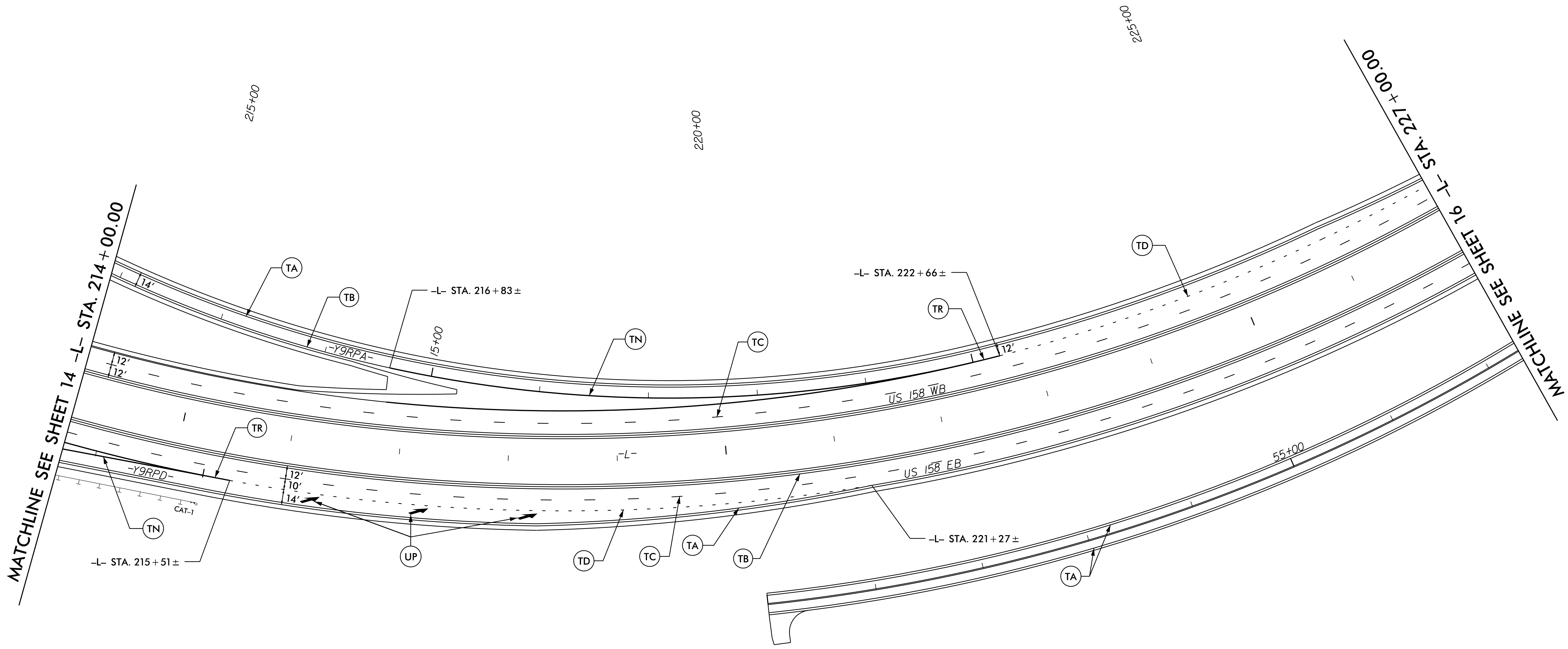
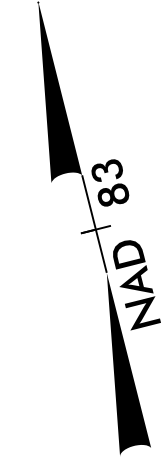

20-MAR-2013 16:03
R-2582A-14B.dgn
J. Stuart Bourne

TIP NO. R-2582A	SHEET NO. PMP-15
APPROVED: <i>J. Stuart Bourne</i> DATE: 3/25/2019	
SEAL	
Prepared in the Office of: SUMMIT <small>ROAD AND CONSTRUCTION SERVICES</small>	
<small>NC FIRM LICENSE No. P-0239 504 Meadowlands Drive Hillsborough, NC 27278 (919) 732-3882 (919) 732-6676 (FAX)</small>	

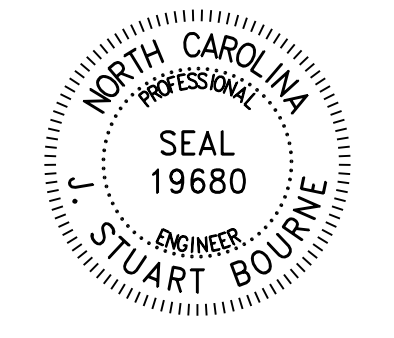

PAVEMENT MARKING DETAIL

20-MAR-2019 16:03
 R-2582A-PMP-15.dgn
 J. Stuart Bourne

TIP NO. R-2582A	SHEET NO. PMP-16
APPROVED: <i>J. Stuart Bourne</i> DATE: 3/25/2019	
SEAL	
	
Prepared in the Office of:  SUMMIT <small>ROAD AND CONSTRUCTION SERVICES</small>	
<small>NC FIRM LICENSE No. P-0239 504 Meadowslands Drive Hillsborough, NC 27278 (919) 732-3885 (919) 732-6676 (FAX)</small>	

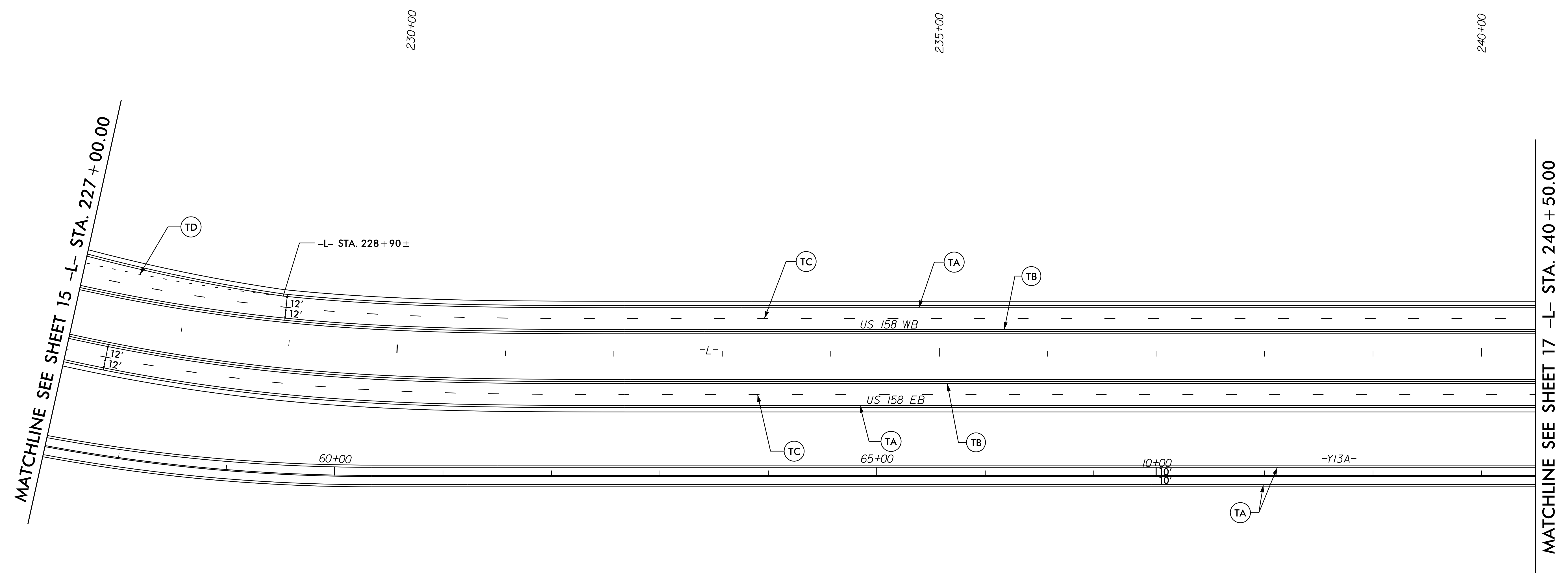
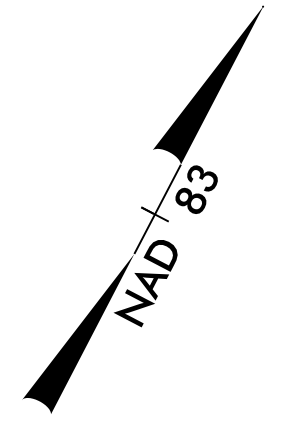

PAVEMENT MARKING DETAIL

R5-MAR-2019 09:46
 R-2582A.dwg
 J. Stuart Bourne

TIP NO. R-2582A	SHEET NO. PMP-17
APPROVED: <i>J. Stuart Bourne</i> <small>DESIGNED BY</small>	
DATE: 3/25/2019 <small>20180607091246D</small>	
SEAL	
Prepared in the Office of:	
	<small>NC FIRM LICENSE No. P-0239 504 Meadowlands Drive Hillsborough, NC 27278 (919) 732-3883 (919) 732-6676 (FAX)</small>

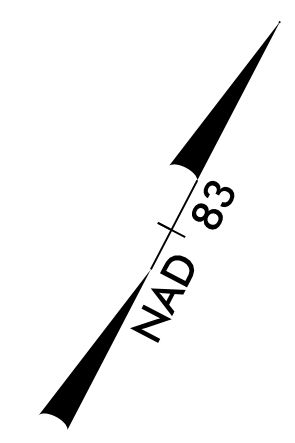

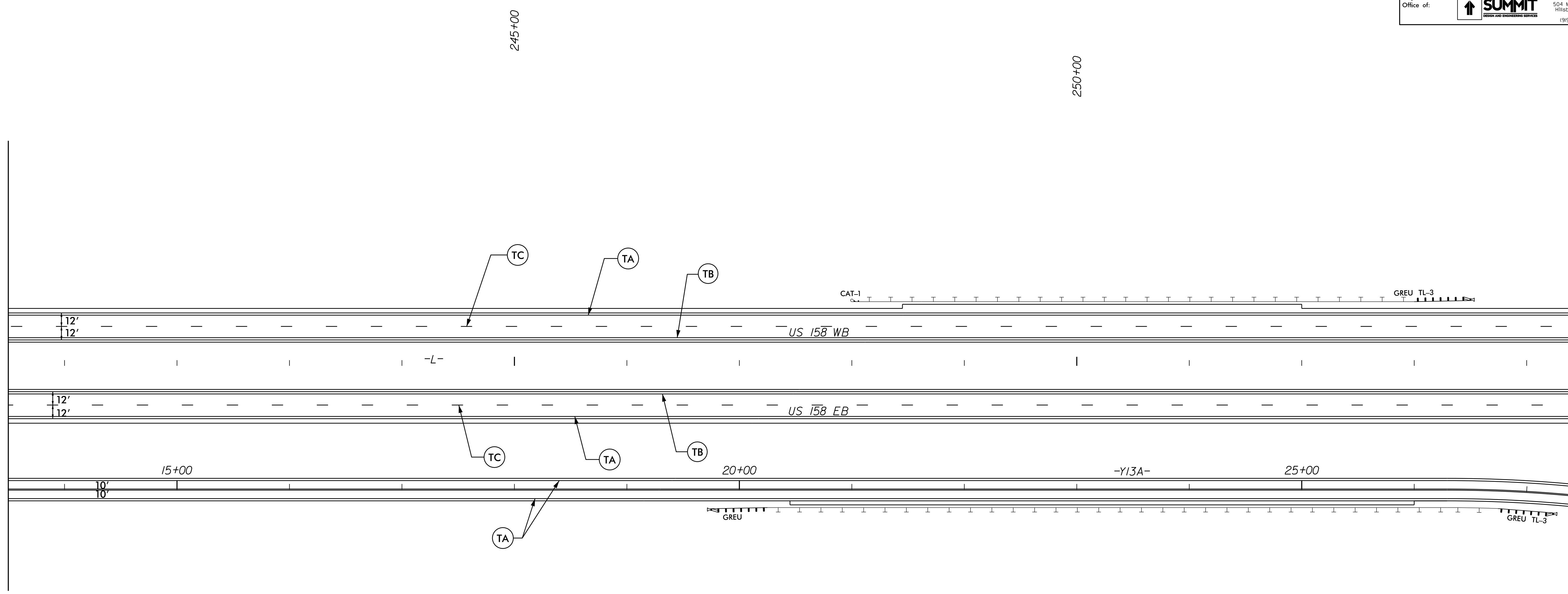

MATCHLINE SEE SHEET 16 -L- STA. 240 + 50.00

MATCHLINE SEE SHEET 18 -L- STA. 254 + 50.00

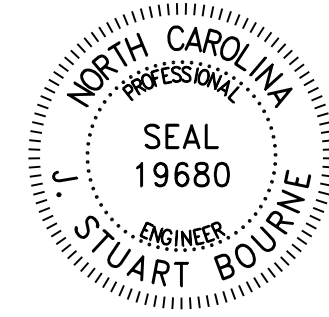

20-MAR-2019 16:04
R-2582A-TIP-PMP-17.dgn
jstuart@summit

PAVEMENT MARKING DETAIL

TIP NO. R-2582A	SHEET NO. PMP-18
APPROVED: <i>J. Stuart Bourne</i> 20190327091246D	
DATE: 3/25/2019	
SEAL	
	
Prepared in the Office of:  SUMMIT <small>ENGINEERING SERVICES</small>	
<small>NC FIRM LICENSE No. P-0239 504 Meadowlands Drive Hillsborough, NC 27278 (919) 732-3883 (919) 732-6676 (FAX)</small>	

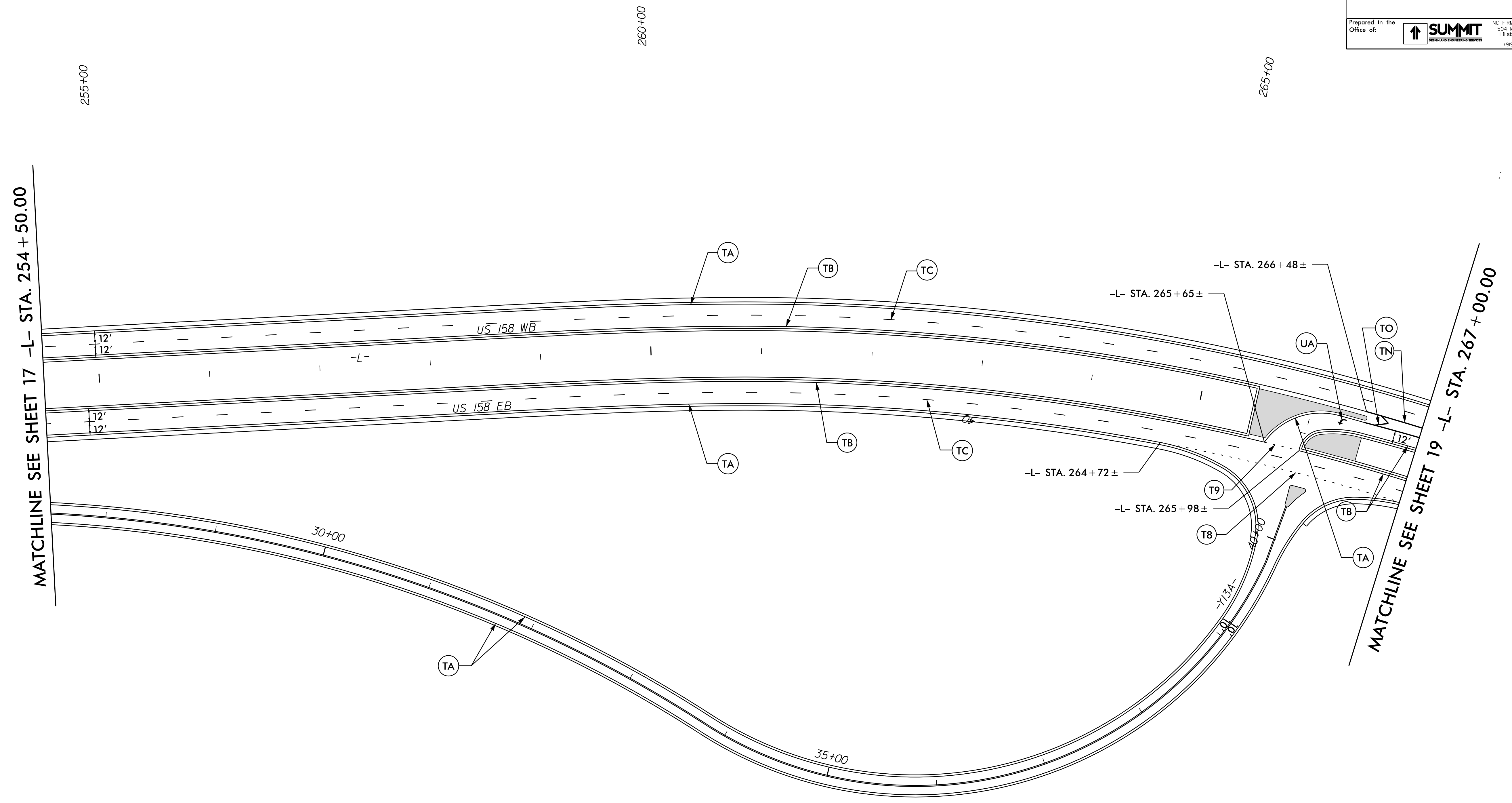
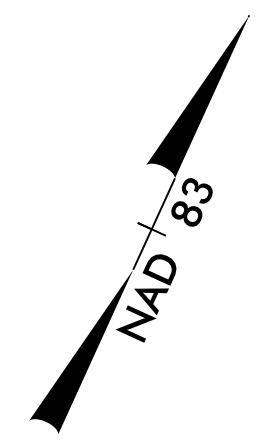

PAVEMENT MARKING DETAIL

20-MAR-2019 16:04
 R-2582A-TIP-PMP-18.dgn
 J. Stuart Bourne

TIP NO. R-2582A	SHEET NO. PMP-19
APPROVED: <i>J. Stuart Bourne</i> DATE: 3/25/2019	
SEAL	
Prepared in the Office of: SUMMIT <small>CONSTRUCTION SERVICES</small>	
<small>NC FIRM LICENSE No. P-0239 504 Meadowlands Drive Hillsborough, NC 27278 (919) 732-3883 (919) 732-6676 (FAX)</small>	

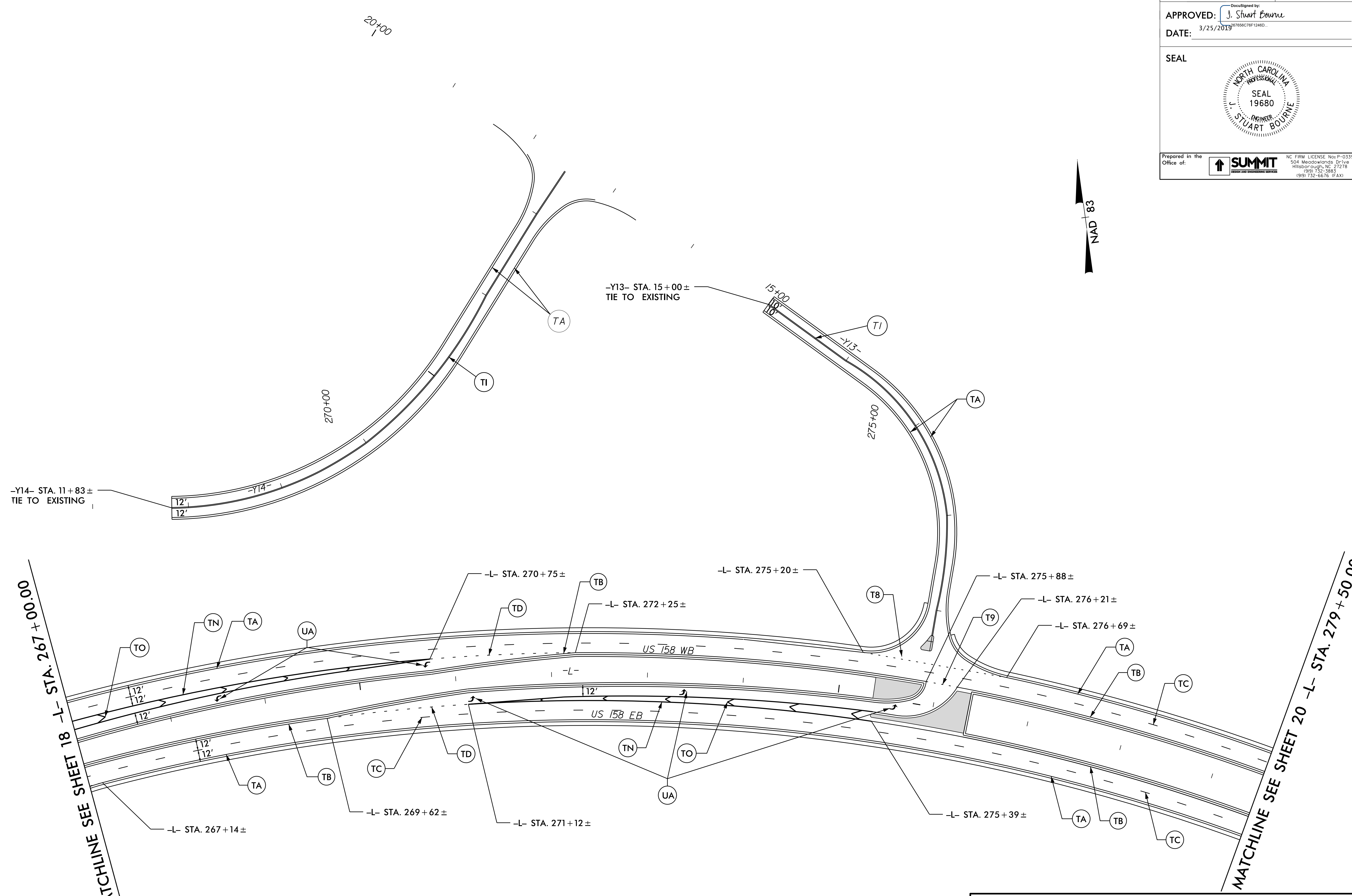

PAVEMENT MARKING DETAIL

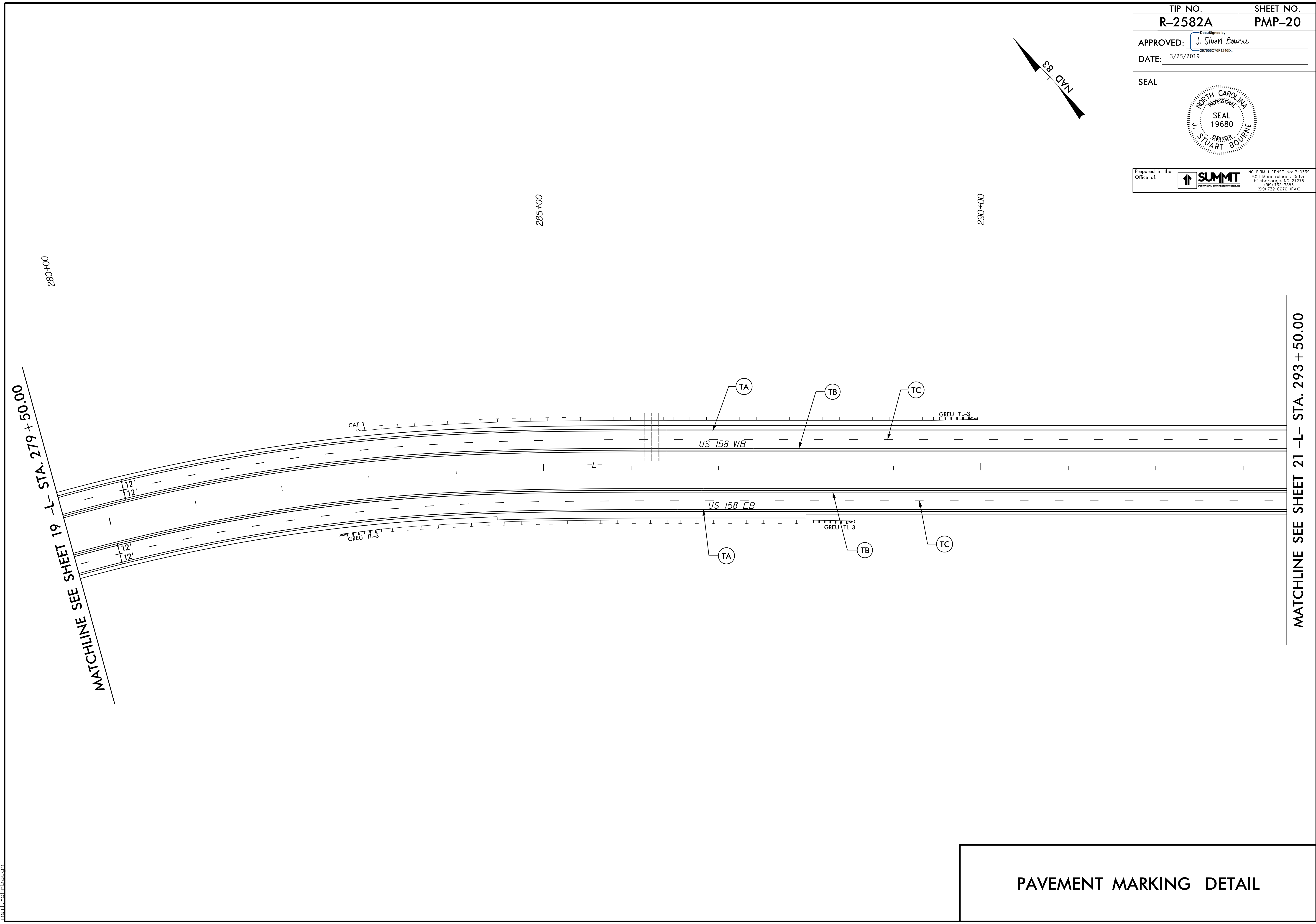
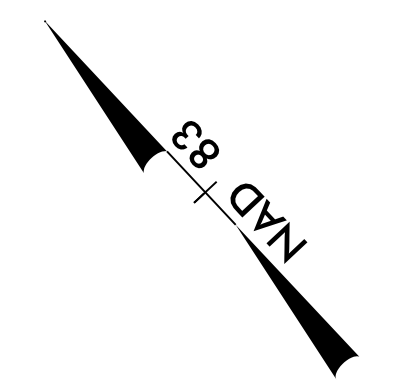

20-MAR-2019 16:05
 R-2582A-TIP-PMP-19.dgn
 J. Stuart Bourne

TIP NO. R-2582A	SHEET NO. PMP-20
APPROVED: <i>J. Stuart Bourne</i> <small>287856CT6P-12460...</small>	
DATE: 3/25/2019	
SEAL	
Prepared in the Office of:	
	<small>NC FIRM LICENSE No. P-0239 504 Meadowslands Drive Hillsborough, NC 27278 (919) 732-3883 (919) 732-6676 (FAX)</small>

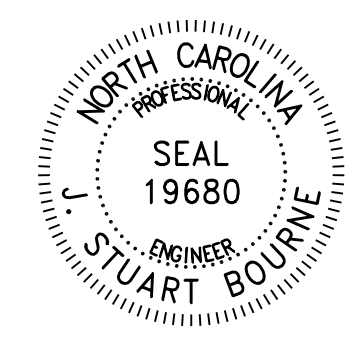

PAVEMENT MARKING DETAIL

20_MAR_2019_16:05
 R-2582A_PMP-20.dgn
 jstuart@summiteng.com

TIP NO. R-2582A	SHEET NO. PMP-21
APPROVED: <i>J. Stuart Bourne</i> 287856C78F1248D...	
DATE: 3/25/2019	
SEAL	
	
Prepared in the Office of:	
	<small>NC FIRM LICENSE No. P-0239 504 Meadowlands Drive Hillsborough, NC 27278 (919) 732-3883 (919) 732-6676 (FAX)</small>

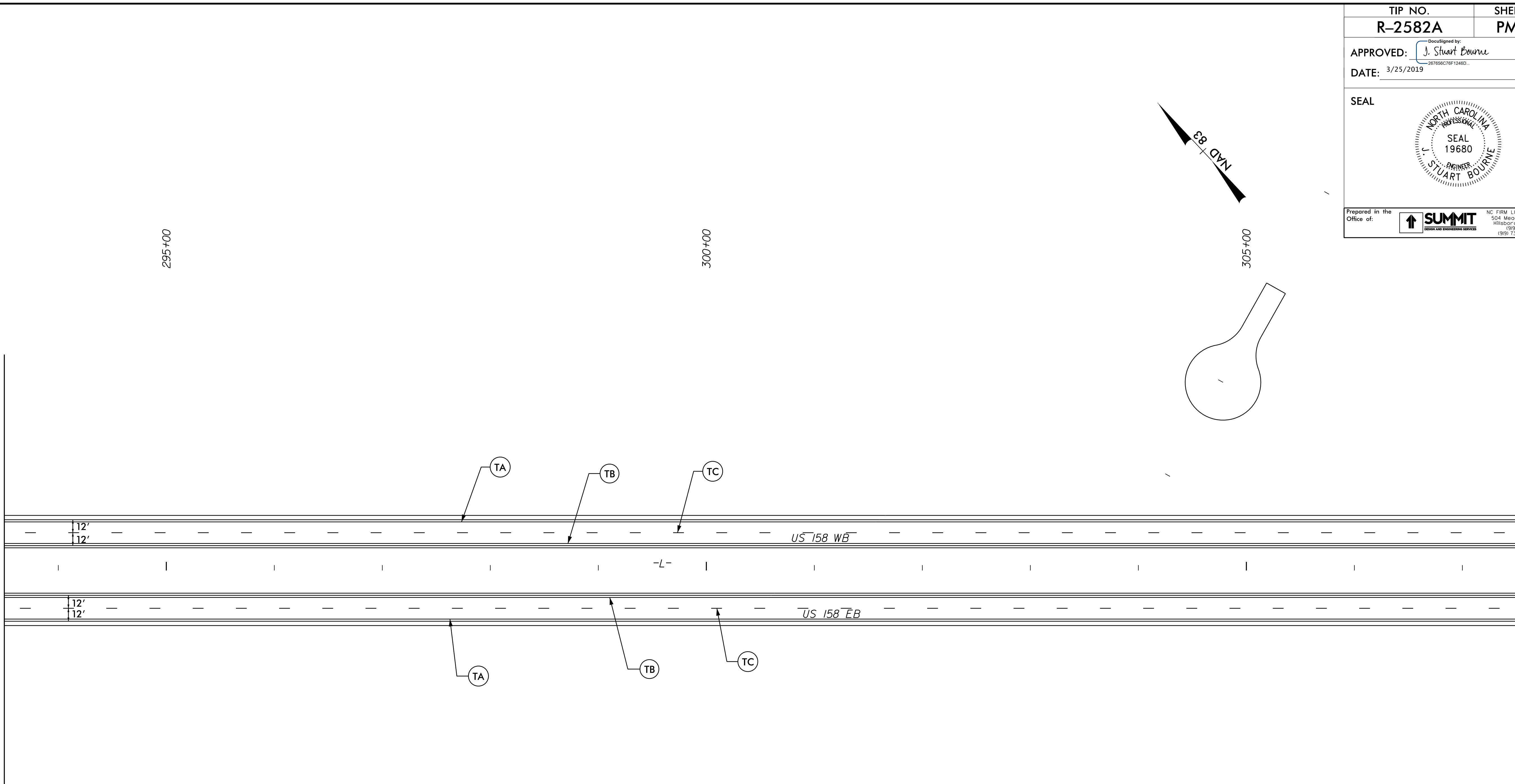

MATCHLINE SEE SHEET 20 -L- STA. 293 + 50.00

MATCHLINE SEE SHEET 22 -L- STA. 307 + 50.00

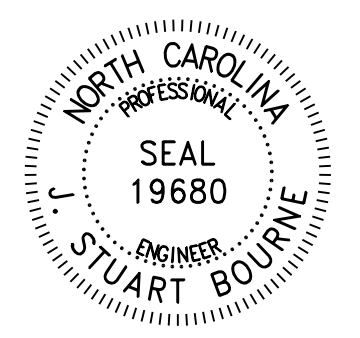

PAVEMENT MARKING DETAIL

20-MAR-2019 16:06
R-2582A.dgn
J. Stuart Bourne

TIP NO. R-2582A	SHEET NO. PMP-22
APPROVED: <i>J. Stuart Bourne</i>	
DATE: 3/25/2019	
SEAL	
	
Prepared in the Office of:  SUMMIT <small>ENGINEERING SERVICES</small>	
<small>NC FIRM LICENSE No. P-0239 504 Meadowlands Drive Hillsborough, NC 27278 (919) 732-3883 (919) 732-6676 (FAX)</small>	

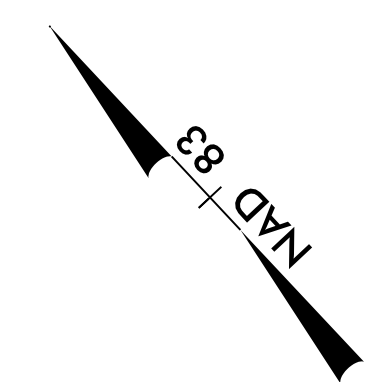

MATCHLINE SEE SHEET 21 -L- STA. 307 + 50.00

MATCHLINE SEE SHEET 23 -L- STA. 321 + 50.00

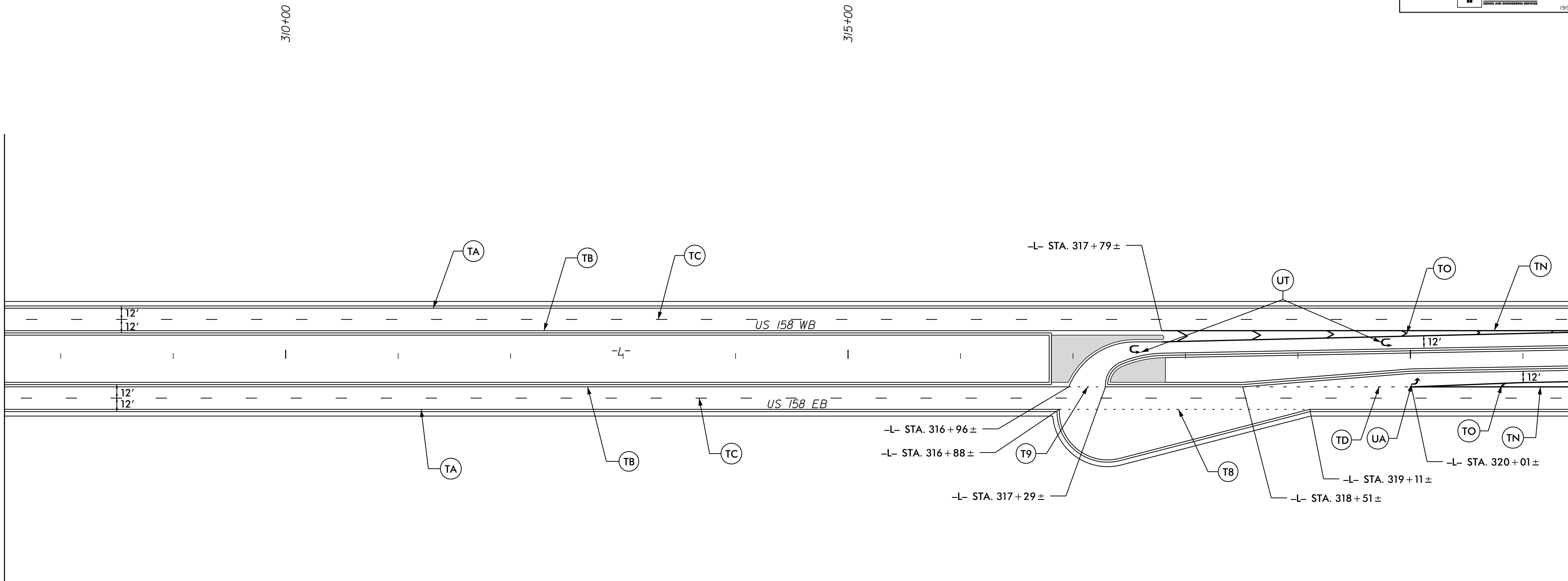

310+00

315+00

20-MAR-2019 16:06
 R-2582A-TIP-PMP-22.dgn
 jstuart@summiteng.com

PAVEMENT MARKING DETAIL

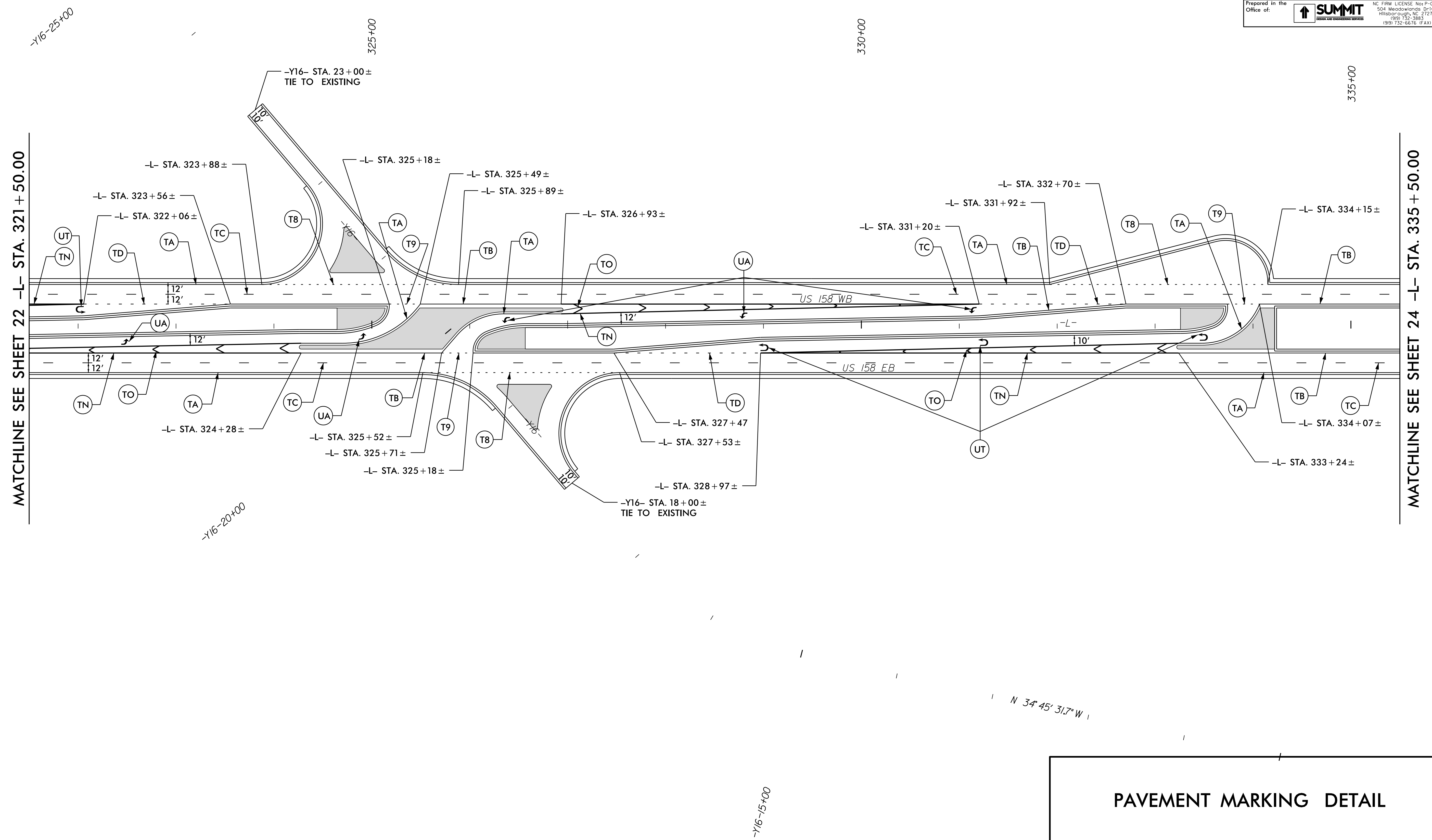
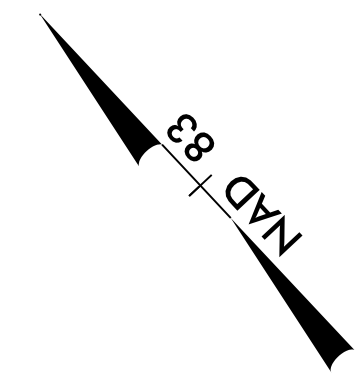

TIP NO. R-2582A	SHEET NO. PMP-23
APPROVED: <i>J. Stuart Bourne</i>	
DATE: 3/25/2019	
SEAL	
Prepared in the Office of: SUMMIT <small>ROAD AND CONSTRUCTION SERVICES</small>	
<small>NC FIRM LICENSE No. P-0239 504 Meadowlands Drive Hillsborough, NC 27278 (919) 732-3882 (919) 732-6676 (FAX)</small>	



PAVEMENT MARKING DETAIL

20-MAR-2019 16:07
 R-2582A PMP-23.dgn
 jstuart@summiteng.com

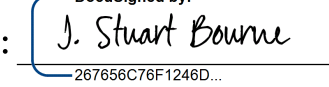
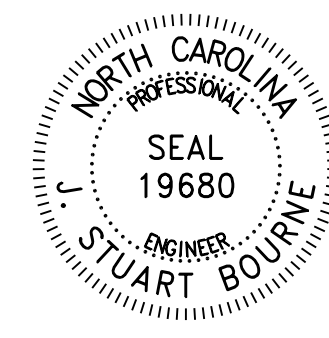
-Y16-15+00

TIP NO. R-2582A	SHEET NO. PMP-24
APPROVED:  20190327012480	
DATE: 3/25/2019	
SEAL	
	
Prepared in the Office of:	 <small>NC FIRM LICENSE No. P-0239 504 Meadowlands Drive Hillsborough, NC 27278 (919) 732-3883 (919) 732-6676 (FAX)</small>

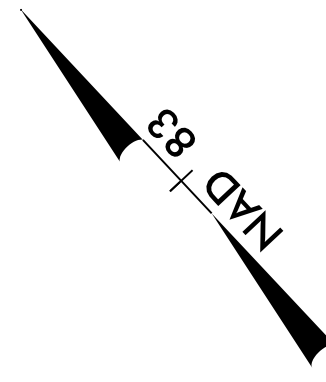

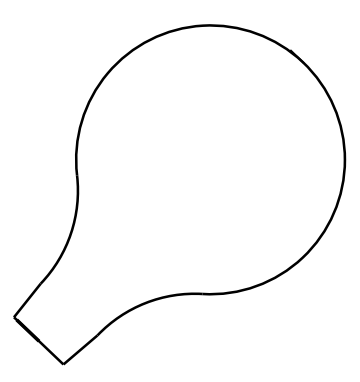
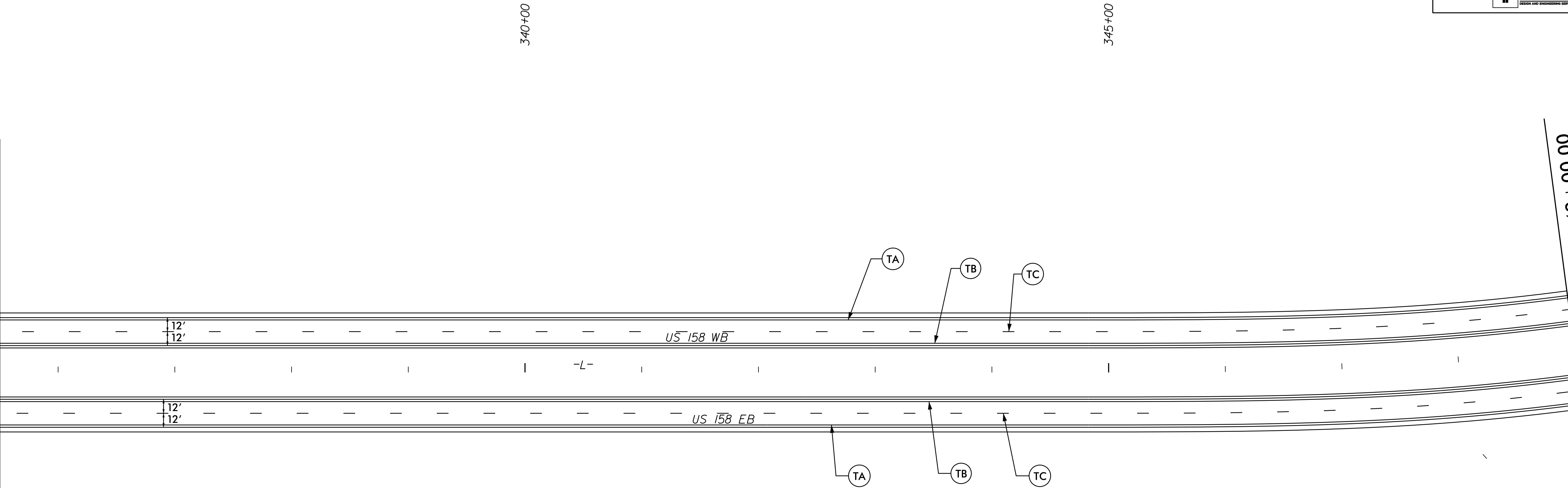

MATCHLINE SEE SHEET 23 -L- STA. 335 + 50.00

MATCHLINE SEE SHEET 25 -L- STA. 349 + 00.00

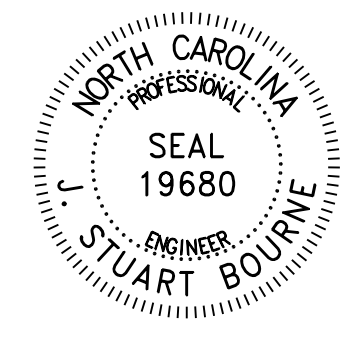

PAVEMENT MARKING DETAIL

20 MAR 2019 16:07
 R-2582A-TIP-FM-24.dgn
 hillsborough

TIP NO. R-2582A	SHEET NO. PMP-25
APPROVED: <i>J. Stuart Bourne</i>	
DATE: 3/25/2019	
SEAL	
	
Prepared in the Office of:  SUMMIT <small>ROAD AND CONSTRUCTION SERVICES</small>	
<small>NC FIRM LICENSE No. P-0239 504 Meadowlands Drive Hillsborough, NC 27278 (919) 732-3883 (919) 732-6676 (FAX)</small>	

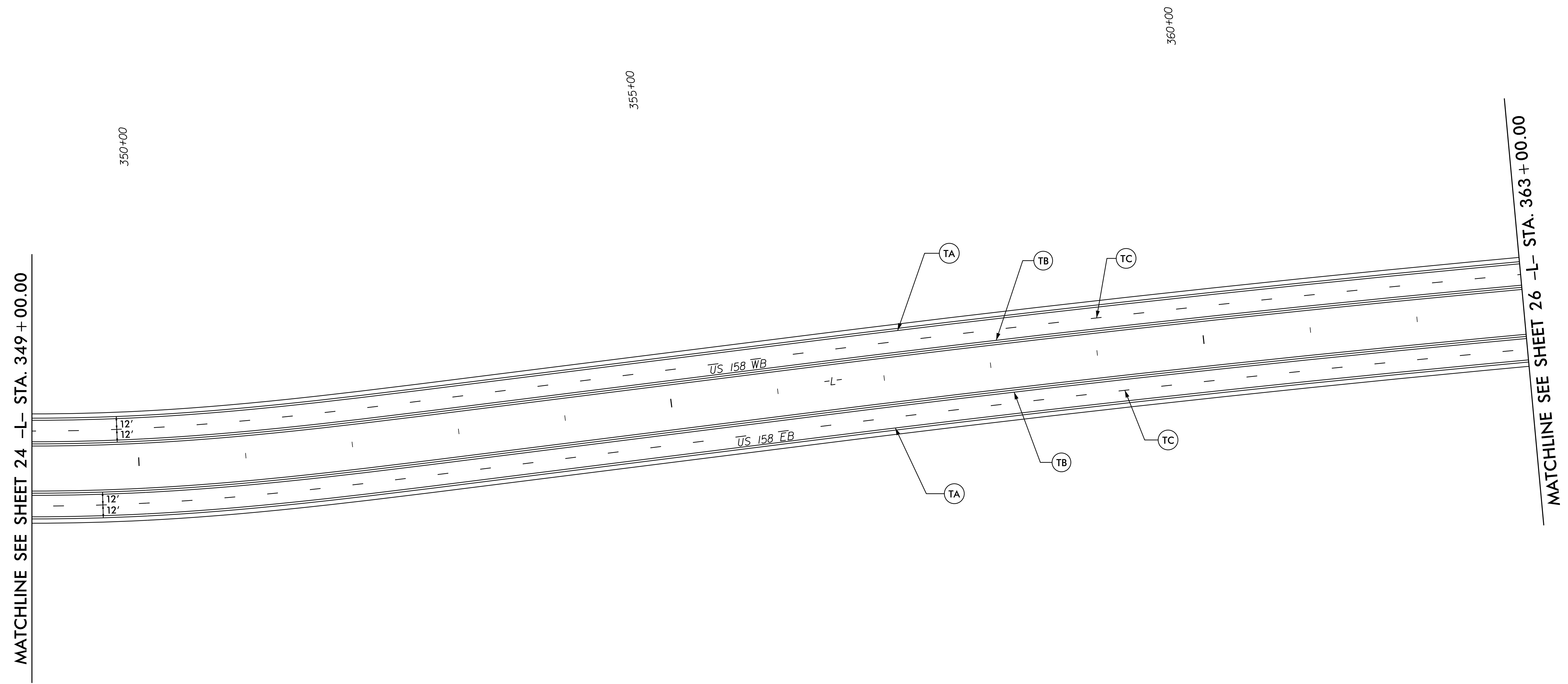
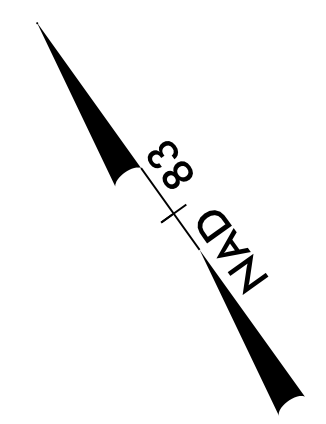

PAVEMENT MARKING DETAIL

20-MAR-2019 16:07
 R-2582A-TIP-PMP-25.dgn
 jstuart@summitnc.com

TIP NO. R-2582A	SHEET NO. PMP-26
APPROVED: <i>J. Stuart Bourne</i> <small>201850C/P/1248D</small>	
DATE: 3/25/2019	
SEAL	
Prepared in the Office of: SUMMIT <small>ROAD AND CONSTRUCTION SERVICES</small>	
<small>NC FIRM LICENSE No. P-0239 504 Meadowlands Drive Hillsborough, NC 27278 (919) 732-3883 (919) 732-6676 (FAX)</small>	

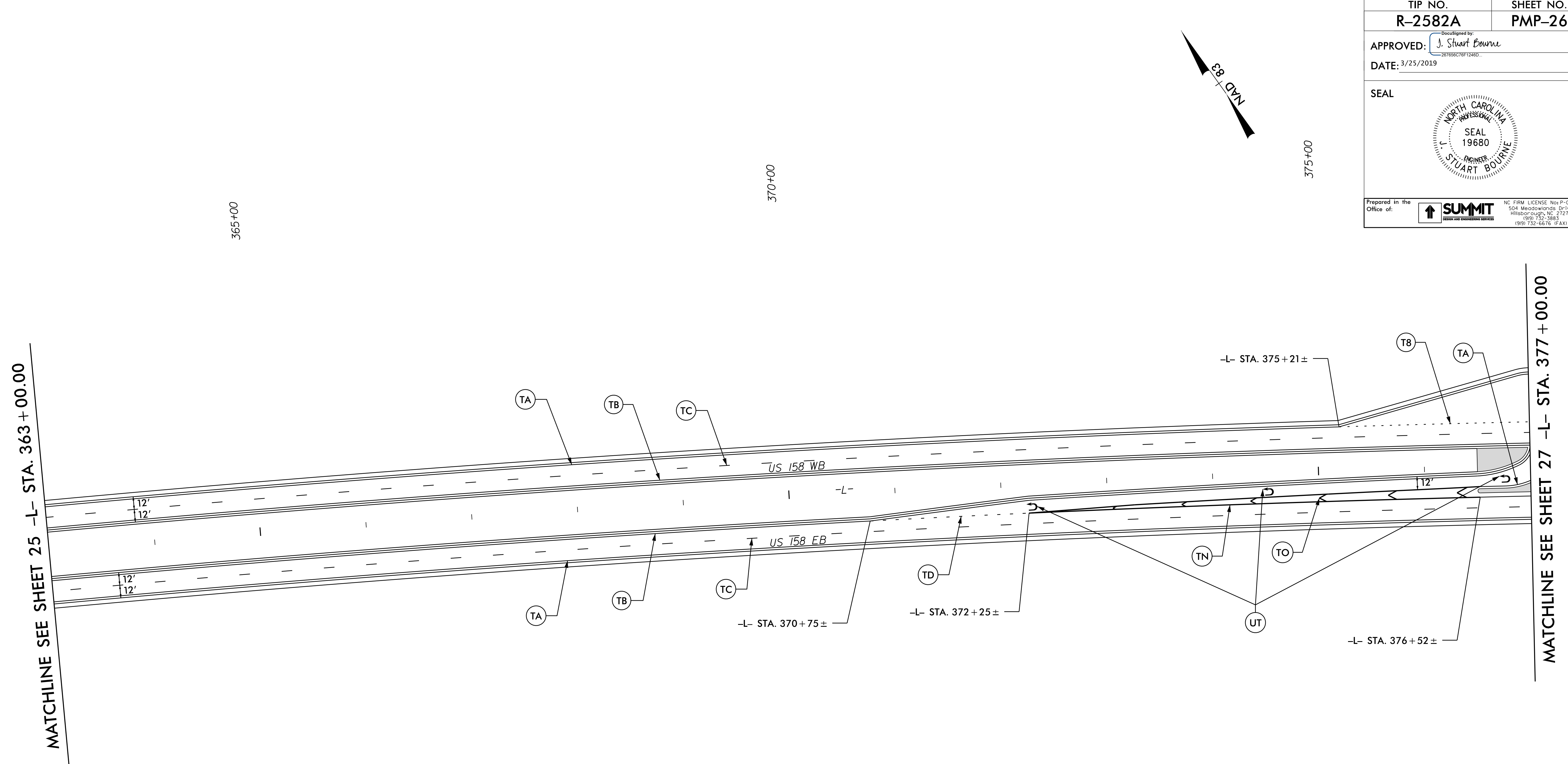
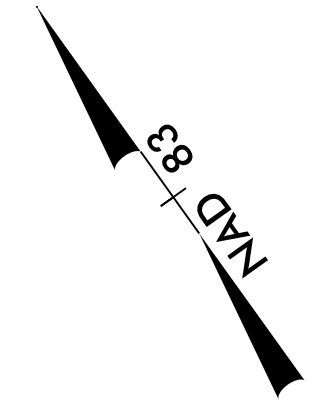



MATCHLINE SEE SHEET 25 -L- STA. 363 + 00.00

MATCHLINE SEE SHEET 27 -L- STA. 377 + 00.00

PAVEMENT MARKING DETAIL

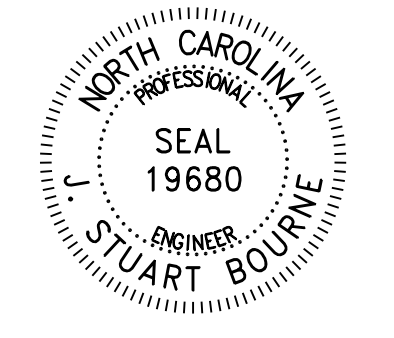
20-MAR-2019 16:08
R-2582A-TIP-PMP-26.dgn
Hillsborough

TIP NO. R-2582A	SHEET NO. PMP-27
APPROVED: <i>J. Stuart Bourne</i>	
DATE: 3/25/2019	
SEAL	
	
Prepared in the Office of: 	
<small>NC FIRM LICENSE No. P-0239 504 Meadowlands Drive Hillsborough, NC 27278 (919) 732-3883 (919) 732-6676 (FAX)</small>	

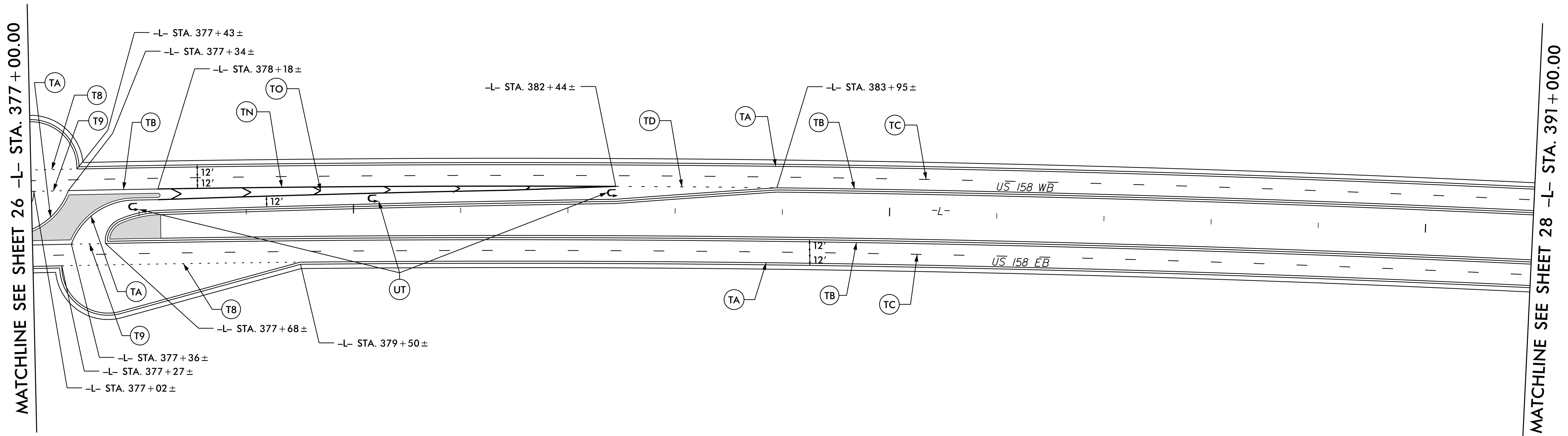
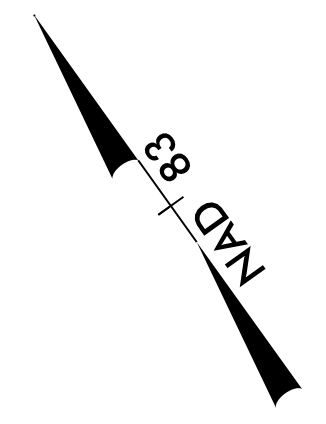

20-MAR-2019 16:08
 R-2582A-TP-PMP-27.dgn
 jstuartbourne

PAVEMENT MARKING DETAIL

TIP NO. R-2582A	SHEET NO. PMP-28
APPROVED: <i>J. Stuart Bourne</i> <small>28765676F1246D...</small>	
DATE: 3/25/2019	
SEAL	
Prepared in the Office of:	
	<small>NC FIRM LICENSE No. P-0239 504 Meadowslands Drive Hillsborough, NC 27278 (919) 732-3883 (919) 732-6676 (FAX)</small>

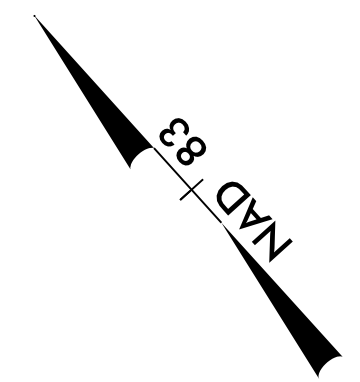

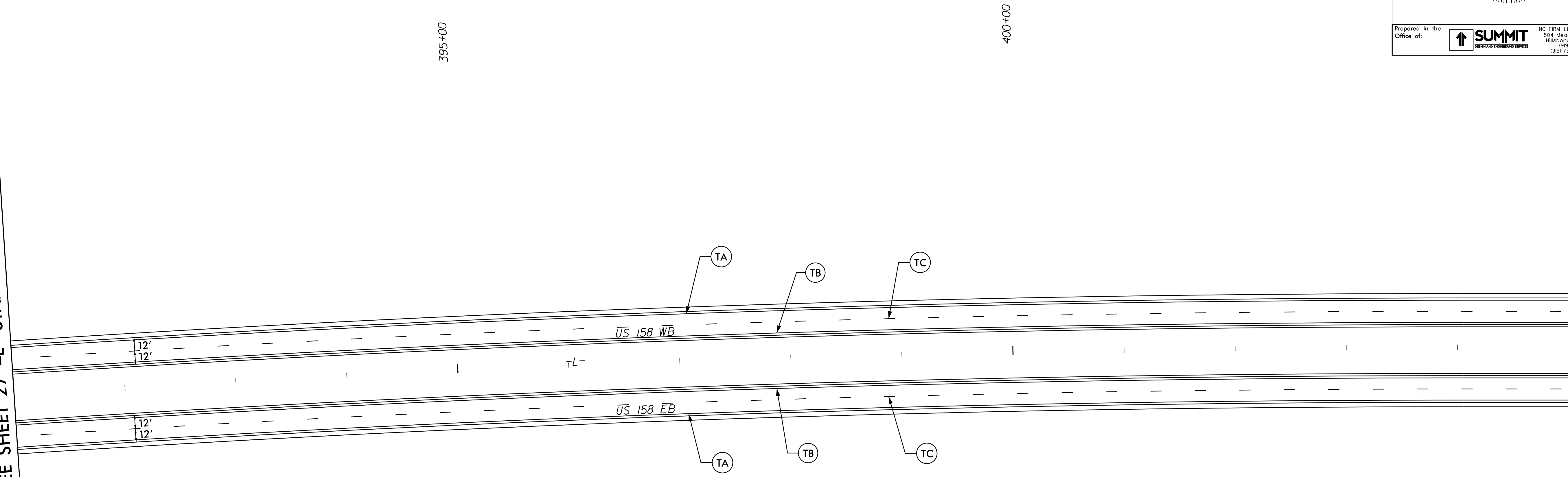

MATCHLINE SEE SHEET 27 -L- STA. 391 + 00.00

MATCHLINE SEE SHEET 29 -L- STA. 405 + 00.00

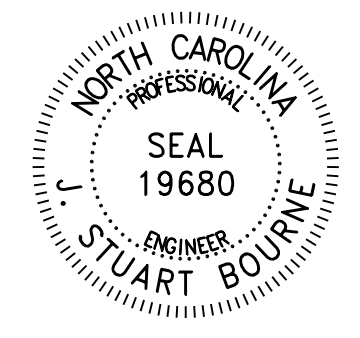

PAVEMENT MARKING DETAIL

20 MAR 2019 16:09
 R-2582A.dwg PMP-28.dgn
 jstuart@summiteng.com

TIP NO. R-2582A	SHEET NO. PMP-29
APPROVED: <i>J. Stuart Bourne</i>	
DATE: 3/25/2019	
SEAL	
	
Prepared in the Office of:	
	<small>NC FIRM LICENSE No. P-0239 504 Meadowlands Drive Hillsborough, NC 27278 (919) 732-3883 (919) 732-6676 (Fax)</small>

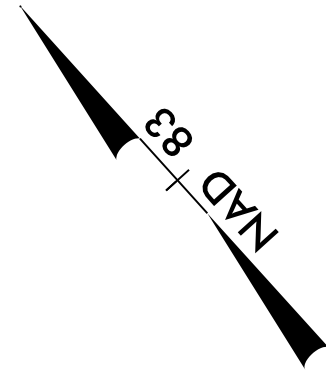

MATCHLINE SEE SHEET 28 -L- STA. 405 + 00.00

405+00

410+00

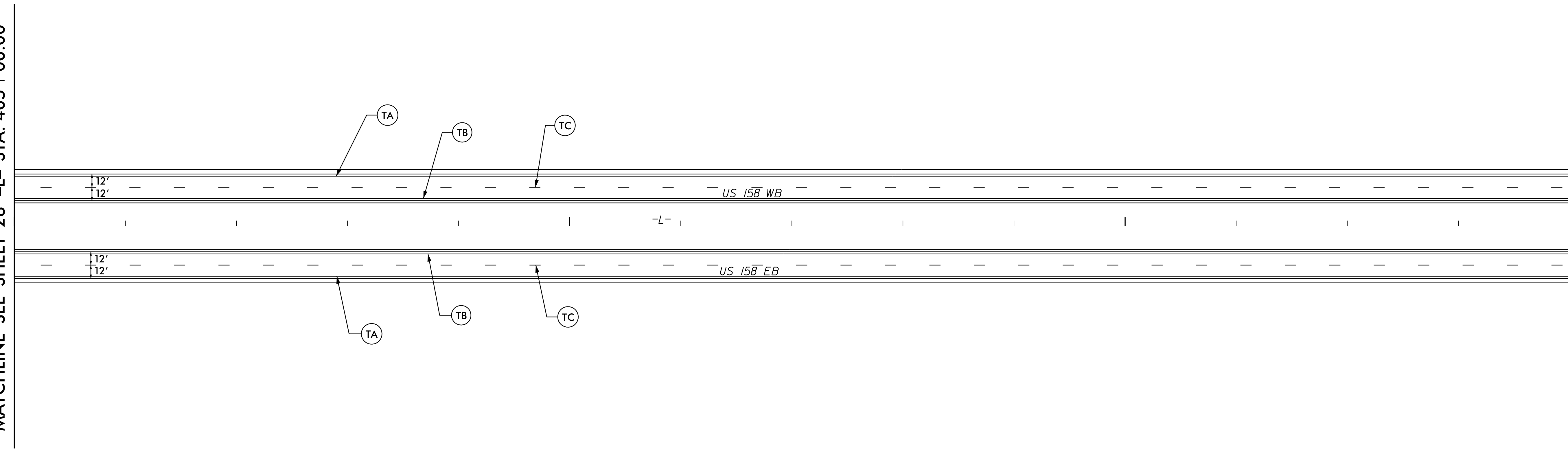

415+00



MATCHLINE SEE SHEET 30 -L- STA. 419 + 00.00

PAVEMENT MARKING DETAIL

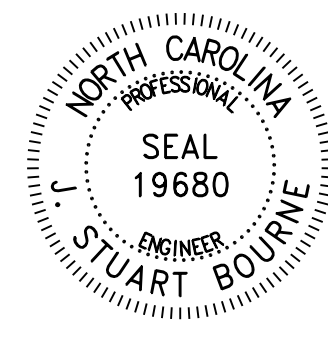
20-MAR-2019 16:10
R-2582A-CP-PMP-29.dgn
nc:\hillsborough

TIP NO. R-2582A	SHEET NO. PMP-30
APPROVED: <i>J. Stuart Bourne</i> <small>DocuSigned by: J. Stuart Bourne 257858C79F1246D...</small>	
DATE: 3/25/2019	
SEAL	
	
Prepared in the Office of:	
	<small>NC FIRM LICENSE No. P-0239 504 Meadowlands Drive Hillsborough, NC 27278 (919) 732-3883 (919) 732-6676 (FAX)</small>

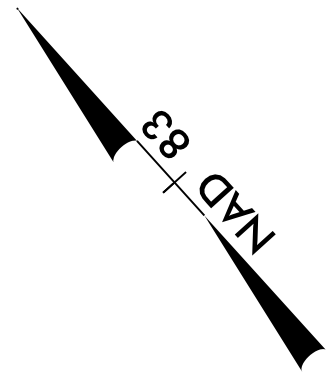

MATCHLINE SEE SHEET 29 -L- STA. 419 + 00.00

MATCHLINE SEE SHEET 31 -L- STA. 433 + 00.00

420+00

425+00

430+00

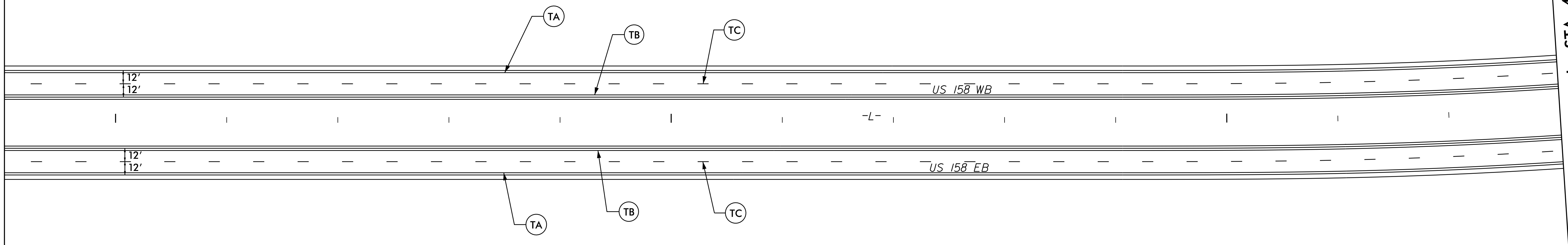

20-MAR-2019 16:10
 R-2582A-CP-PMP-30.dgn
 jstuart@summiteng.com

PAVEMENT MARKING DETAIL

TIP NO. R-2582A	SHEET NO. PMP-31
APPROVED: _____	
DATE: _____	
SEAL	
NOT A CERTIFIED DOCUMENT AS TO THE ORIGINAL DOCUMENT BUT ONLY AS TO THE REVISIONS.	
THIS DOCUMENT ORIGINALLY ISSUED AND SEALED BY :	
J. STUART BOURNE LIC. NO. 019680	
ON 3/25/19	
THIS DOCUMENT IS ONLY CERTIFIED AS TO THE REVISIONS.	
Prepared in the Office of:	 <small>NC FIRM LICENSE No. P-0339 504 Meadowlands Drive Hillsborough, NC 27278 (919) 732-3883 (919) 732-6676 (FAX)</small>

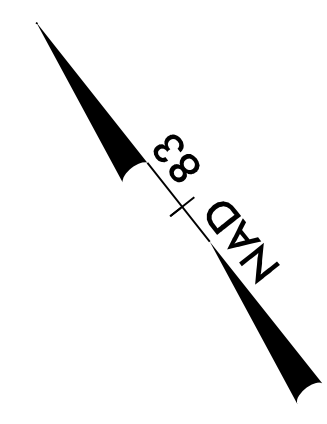

8/13/2020

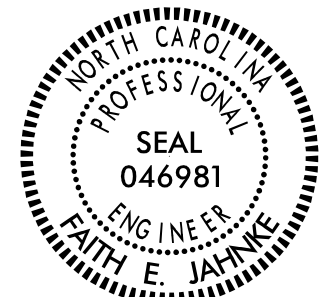

DocuSigned by:
Faith E. Jahnke
FOR REVISION ONLY

REVISIONS
 CONSTRUCTION REVISION: THE CROSSOVER ALIGNMENTS, -L-CR-EBL- AND -L-CR-WBL-, HAVE BEEN REVISED TO AVOID WETLAND IMPACTS AROUND -L- STA. 453+50.00 RT. THE PAVEMENT MARKING HAS BEEN UPDATED TO REFLECT THE CHANGES. JPM 7/7/2020

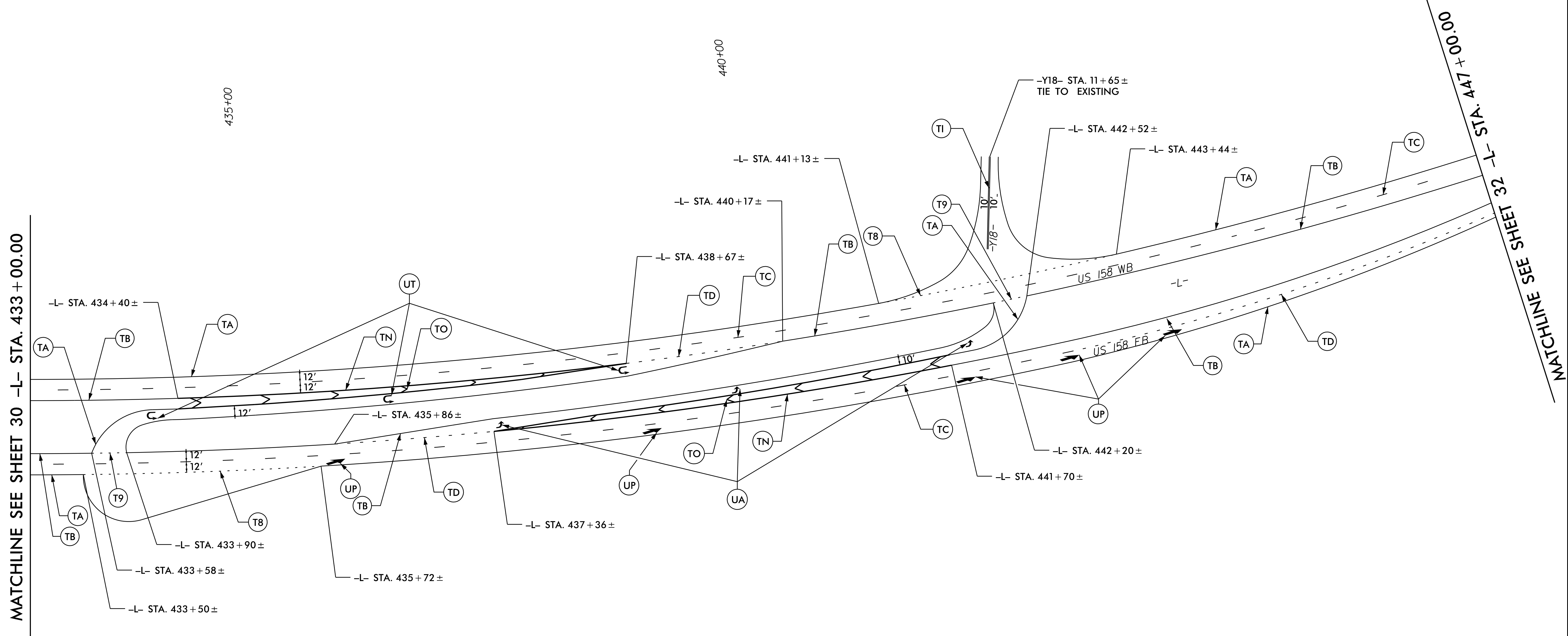

PAVEMENT MARKING DETAIL

13-AUG-2020 08:48
 P:\2582A\TIP\018\31.dgn
 Faith E. Jahnke

TIP NO. R-2582A	SHEET NO. PMP-32
APPROVED: _____	
DATE: _____	
SEAL	
NOT A CERTIFIED DOCUMENT AS TO THE ORIGINAL DOCUMENT BUT ONLY AS TO THE REVISIONS.	
THIS DOCUMENT ORIGINALLY ISSUED AND SEALED BY :	
J. STUART BOURNE LIC. NO. 019680	
ON 3/25/19	
THIS DOCUMENT IS ONLY CERTIFIED AS TO THE REVISIONS.	
Prepared in the Office of:	 <small>NC FIRM LICENSE No. P-0339 504 Meadowlands Drive Hillsborough, NC 27278 (919) 732-3883 (919) 732-6676 (FAX)</small>

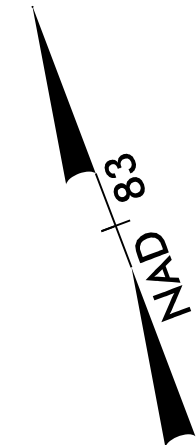

REVISIONS
 CONSTRUCTION REVISION: THE CROSSOVER ALIGNMENTS, -L-CR-EBL- AND -L-CR-WBL- HAVE BEEN REVISED TO AVOID WETLAND IMPACTS AROUND -L- STA. 453+50.00 RT. THE PAVEMENT MARKING HAS BEEN UPDATED TO REFLECT THE CHANGES. JPM 7/7/2020

MATCHLINE SEE SHEET 32 -L- STA. 447 + 00.00

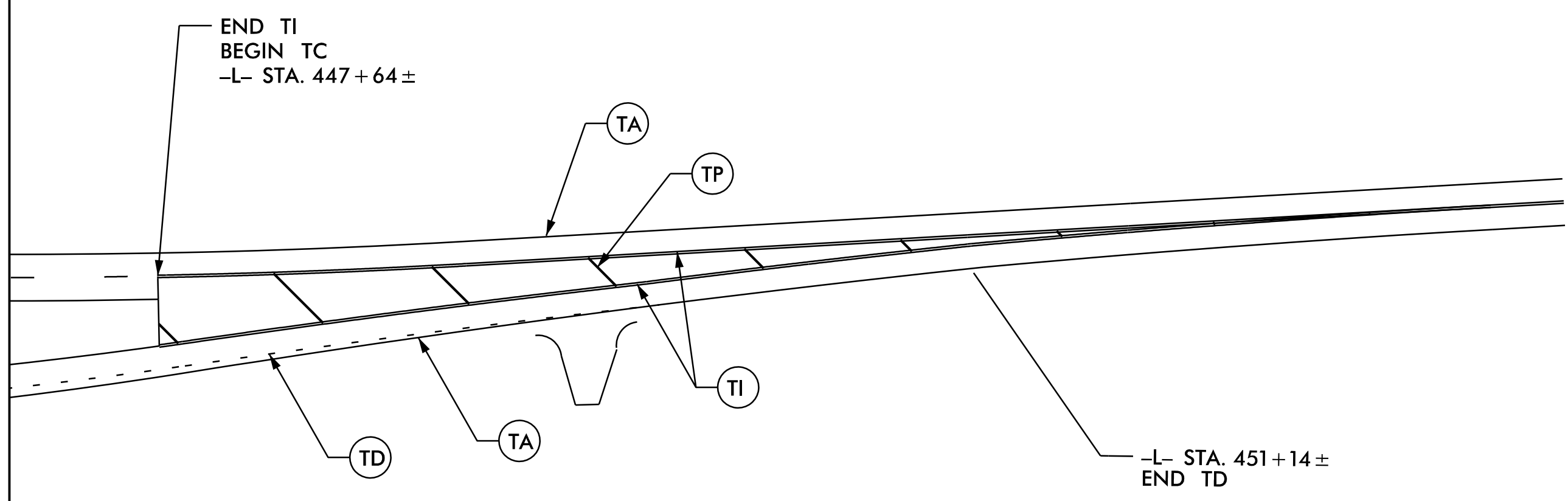

8/13/2020

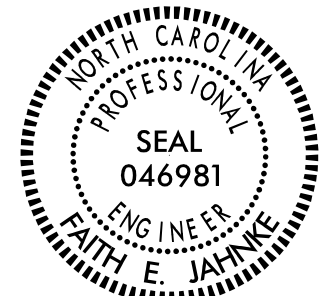



DocuSigned by:
Faith E. Jahnke
000066C570049E

FOR REVISION ONLY

PAVEMENT MARKING DETAIL

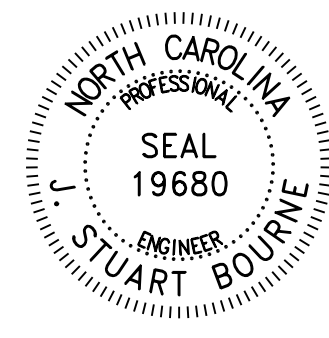
13-AUG-2020 08:48
 R-2582A-TIP-019V-32.dgn
 Faith E. Jahnke

TIP NO. R-2582A	SHEET NO. PMP-33
APPROVED: <u>J. Stuart Bourne</u> <small>DocuSigned by: J. Stuart Bourne 201903251612480</small>	
DATE: 3/25/2019	
SEAL	
	
Prepared in the Office of:	 SUMMIT <small>ROAD AND TRANSPORTATION SERVICES</small>
	<small>NC FIRM LICENSE No. P-0239 504 Meadowlands Drive Hillsborough, NC 27278 (919) 732-3883 (919) 732-6676 (FAX)</small>

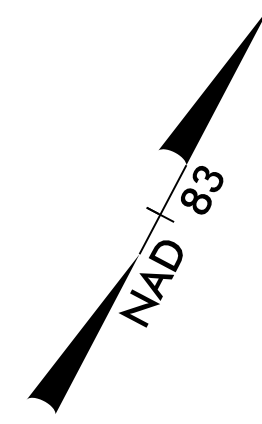

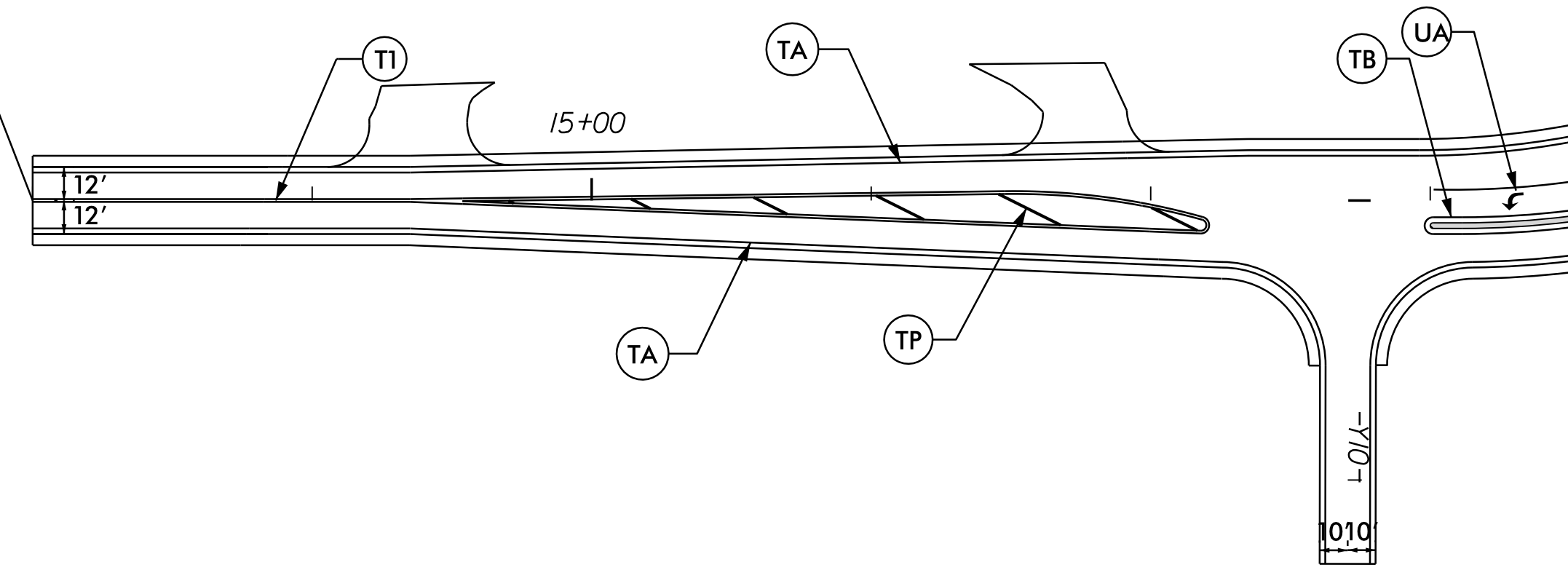

-Y9- STA. 13+00±
TIE TO EXISTING



MATCHLINE SEE SHEET 14 -Y9- STA. 18+50.00

PAVEMENT MARKING DETAIL

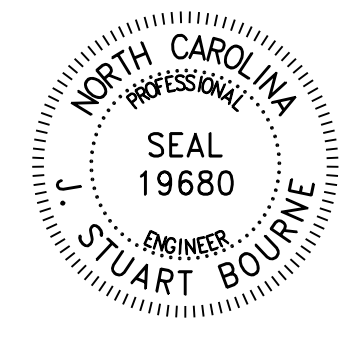
PC-MAR-2019 16:42
 R-2582A-TIP-PMP-33.dgn
 hillsborough

TIP NO. R-2582A	SHEET NO. PMP-34
APPROVED: <i>J. Stuart Bourne</i> <small>DocuSigned by: J. Stuart Bourne 28765076F1246D...</small>	
DATE: 3/25/2019	
SEAL	
	
Prepared in the Office of:	 SUMMIT <small>ROAD AND CONSTRUCTION SERVICES</small>
	<small>NC FIRM LICENSE No. P-0239 504 Meadowlands Drive Hillsborough, NC 27278 (919) 732-3883 (919) 732-6676 (FAX)</small>

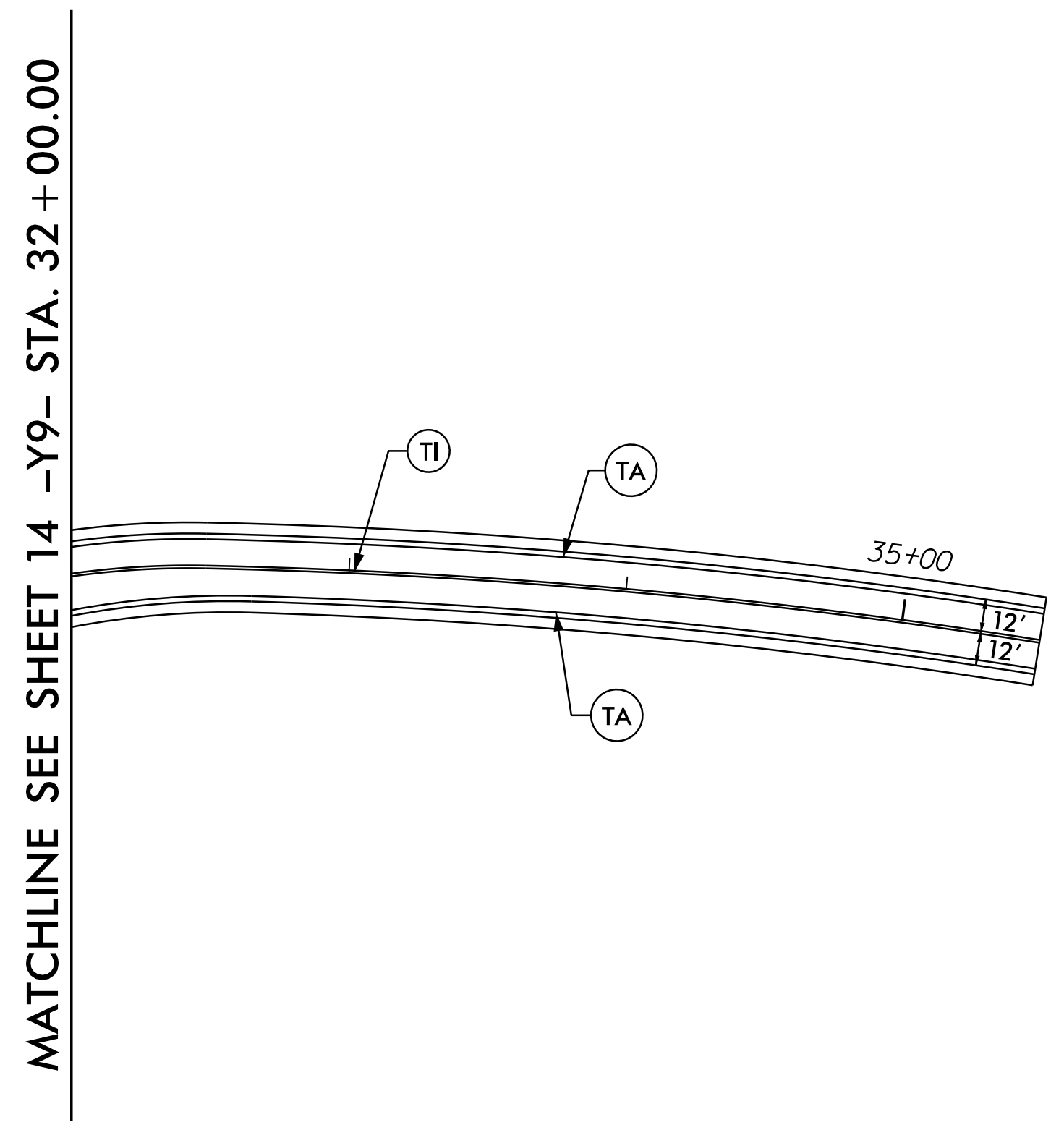
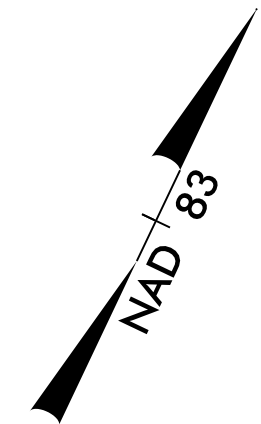

20-MAR-2019 16:42
 R-2582A-PMP-34.dgn
 hillsborough

PAVEMENT MARKING DETAIL