

**This electronic collection of documents is provided
for the convenience of the user
and is Not a Certified Document –**

**The documents contained herein were originally issued
and sealed by the individuals whose names and license
numbers appear on each page, on the dates appearing
with their signature on that page.**

**This file or an individual page
shall not be considered a certified document.**



220 210 200 190 180 170 160 150 140 130 120 110 100 90 80 70 60 50 40 30 20 10 0 10 20 30 40 50 60 70 80

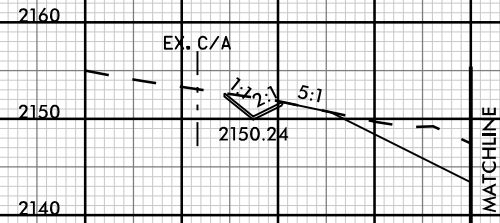

240 230 220 210

MATCHLINE
SEE ABOVE

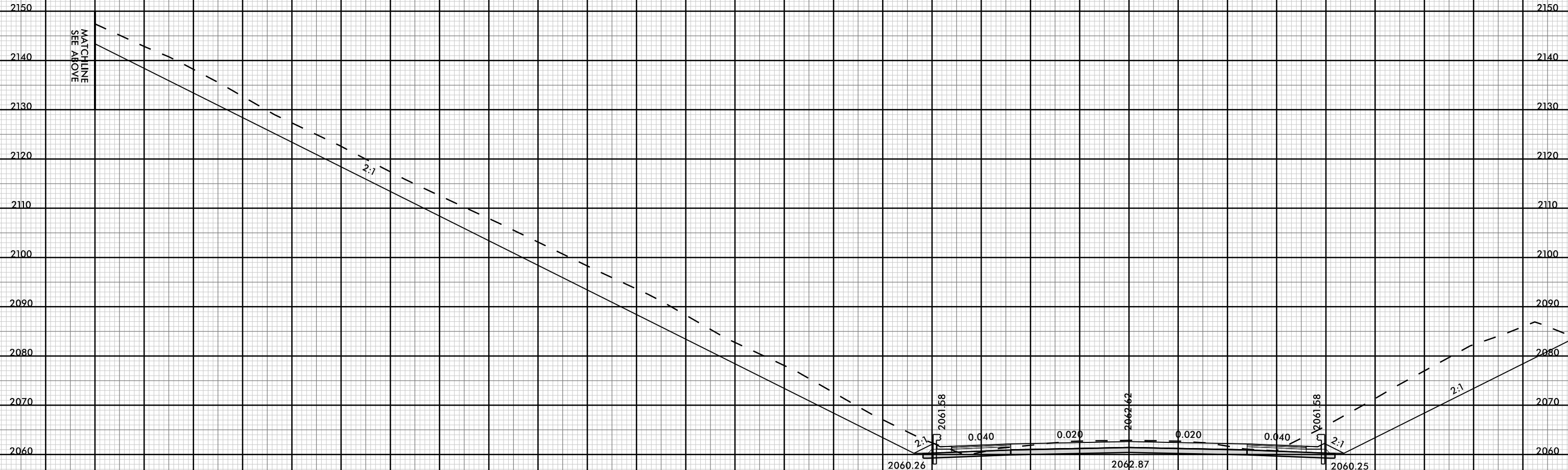

1111 + 50.00

-EBL-

220 210 200 190 180 170 160 150 140 130 120 110 100 90 80 70 60 50 40 30 20 10 0 10 20 30 40 50 60 70 80

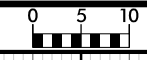

PROJ. REFERENCE NO.	SHEET NO.
I-4700	X-505

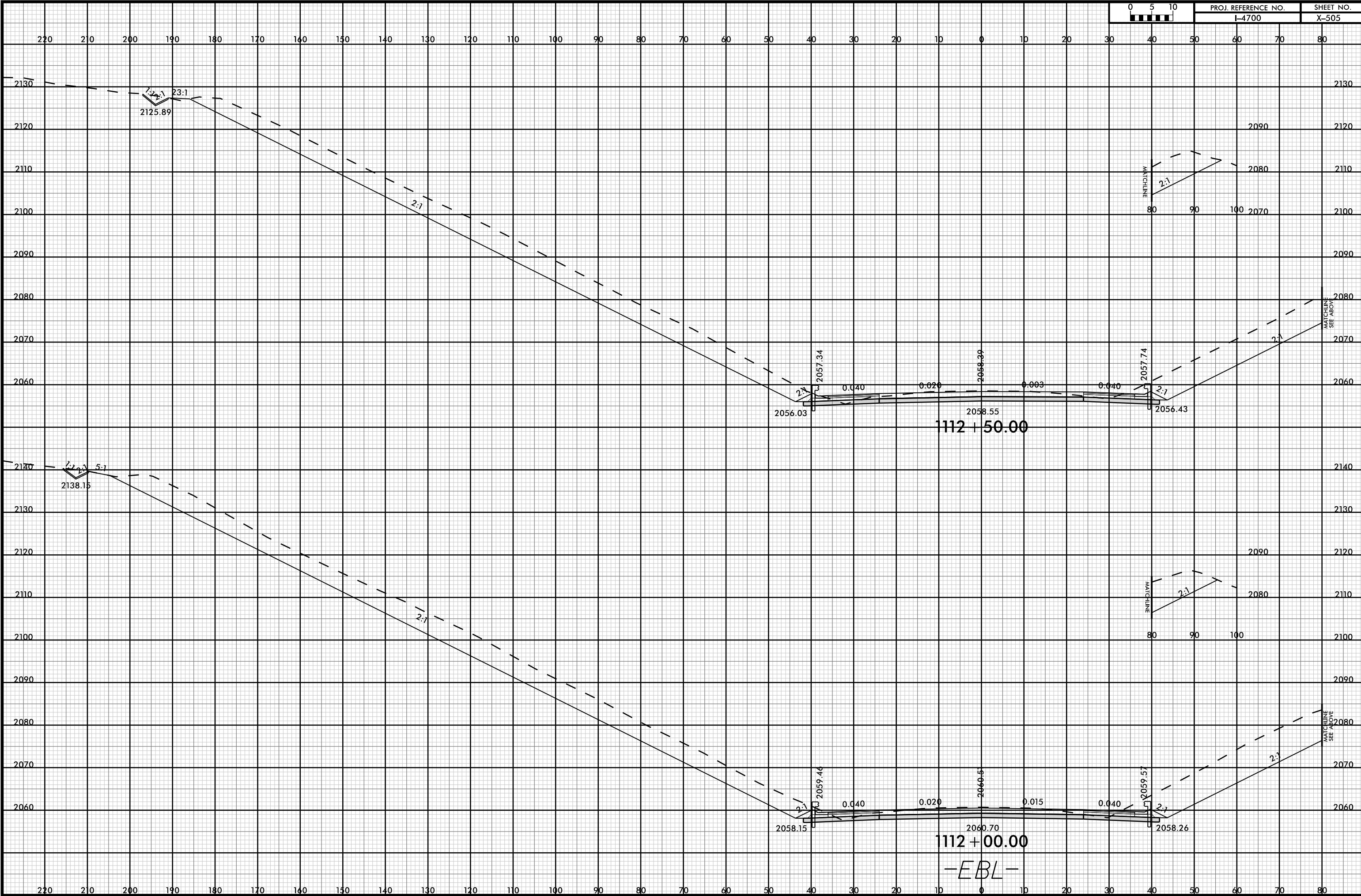

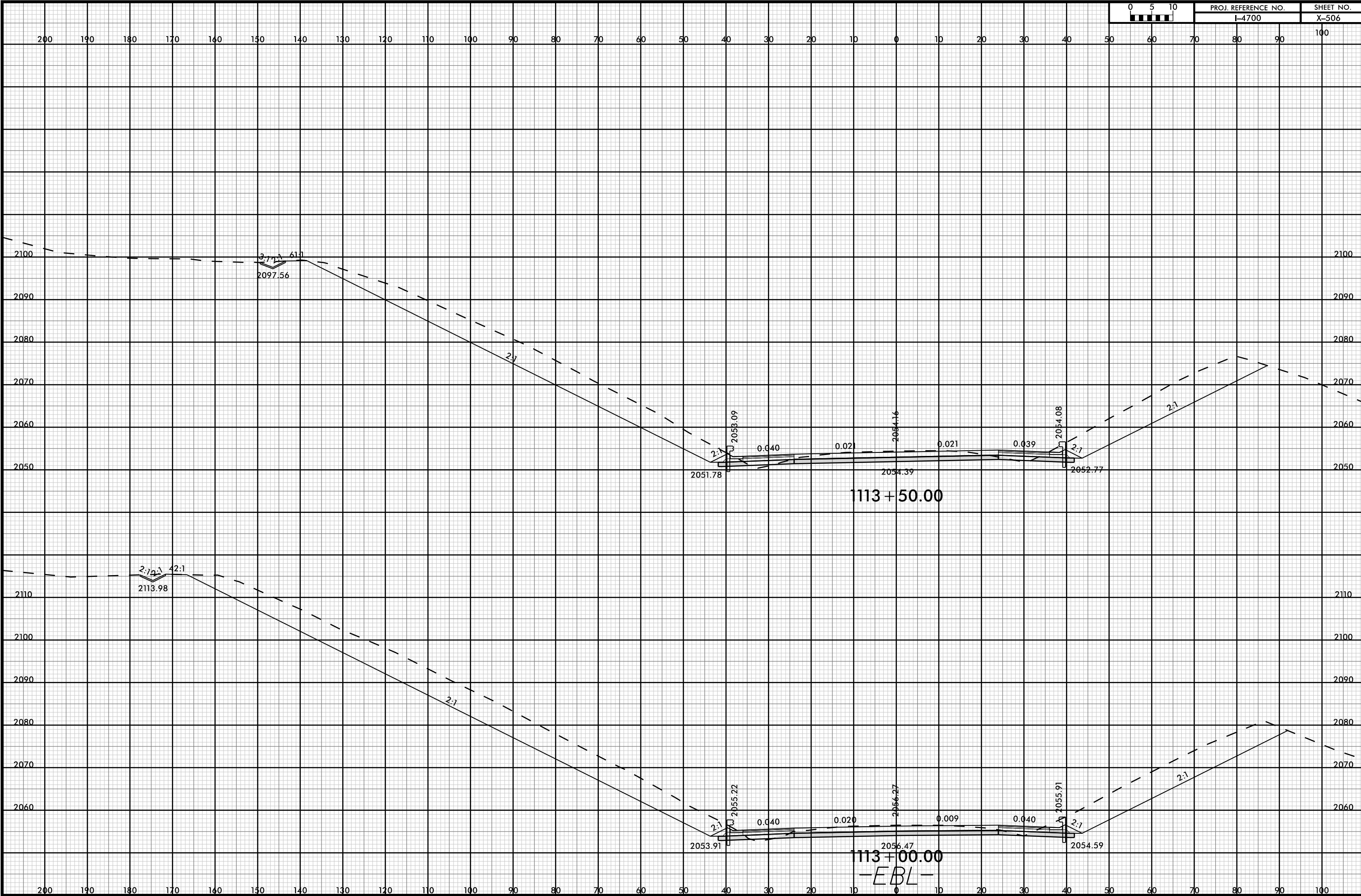

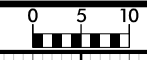

200 190 180 170 160 150 140 130 120 110 100 90 80 70 60 50 40 30 20 10 0 10 20 30 40 50 60 70 80 90 100

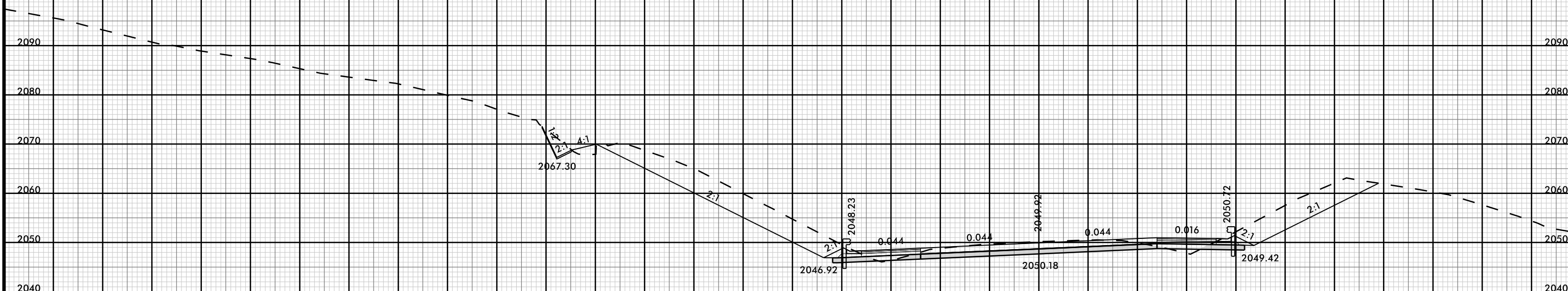

1114 + 50.00

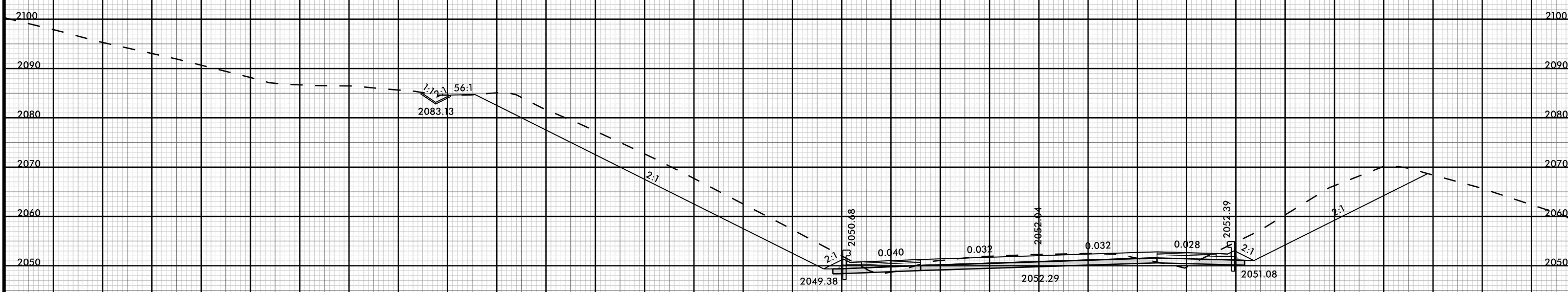

1114 + 00.00

-EBL-

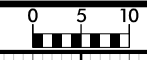

200 190 180 170 160 150 140 130 120 110 100 90 80 70 60 50 40 30 20 10 0 10 20 30 40 50 60 70 80 90 100

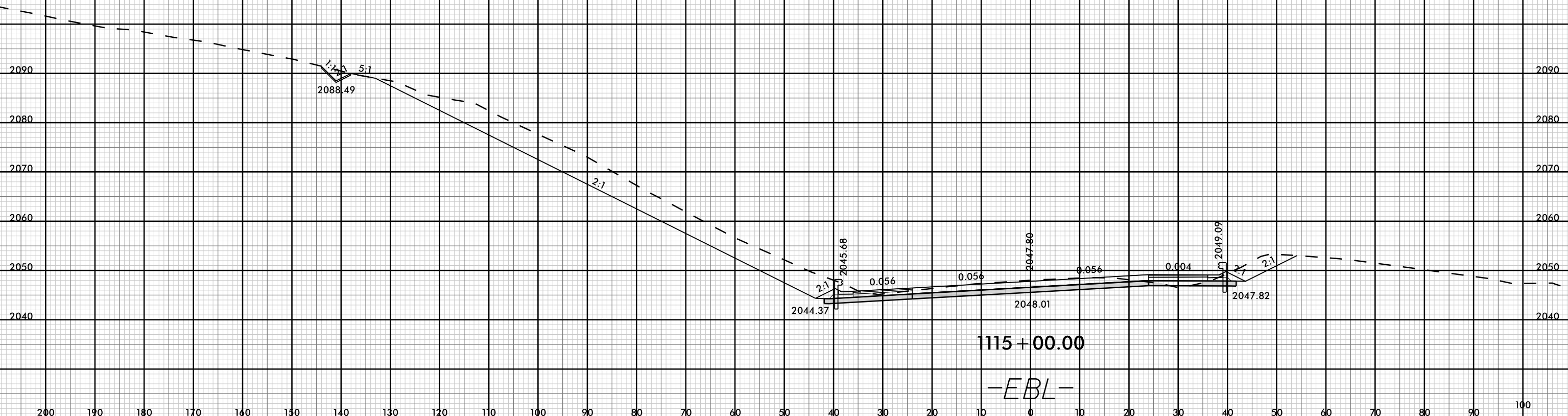
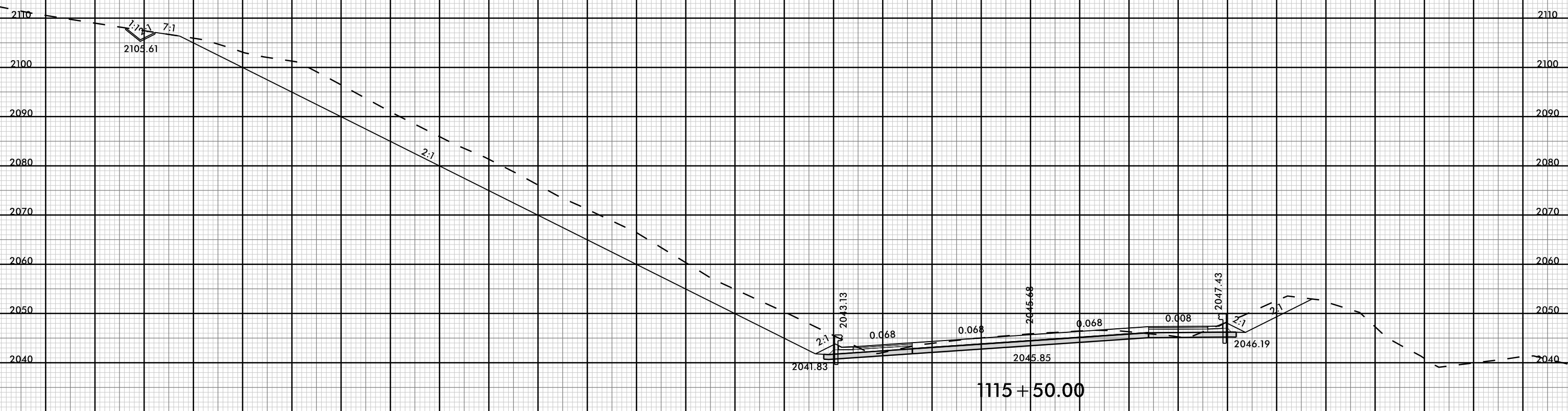

200 190 180 170 160 150 140 130 120 110 100 90 80 70 60 50 40 30 20 10 0 10 20 30 40 50 60 70 80 90 100



210 200 190 180 170 160 150 140 130 120 110 100 90 80 70 60 50 40 30 20 10 0 10 20 30 40 50 60 70 80 90



1116+00.00

-EBL-



210 200 190 180 170 160 150 140 130 120 110 100 90 80 70 60 50 40 30 20 10 0 10 20 30 40 50 60 70 80 90

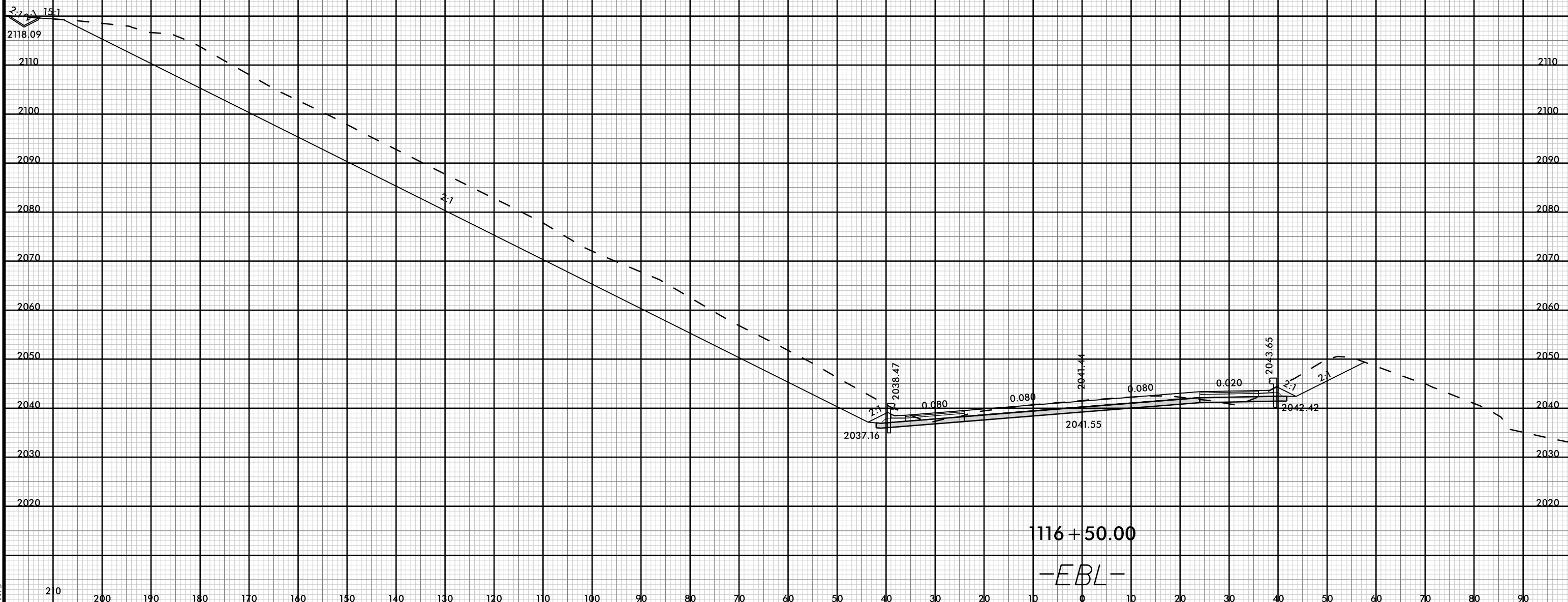

1116 + 50.00

-EBL-



210 200 190 180 170 160 150 140 130 120 110 100 90 80 70 60 50 40 30 20 10 0 10 20 30 40 50 60 70 80 90

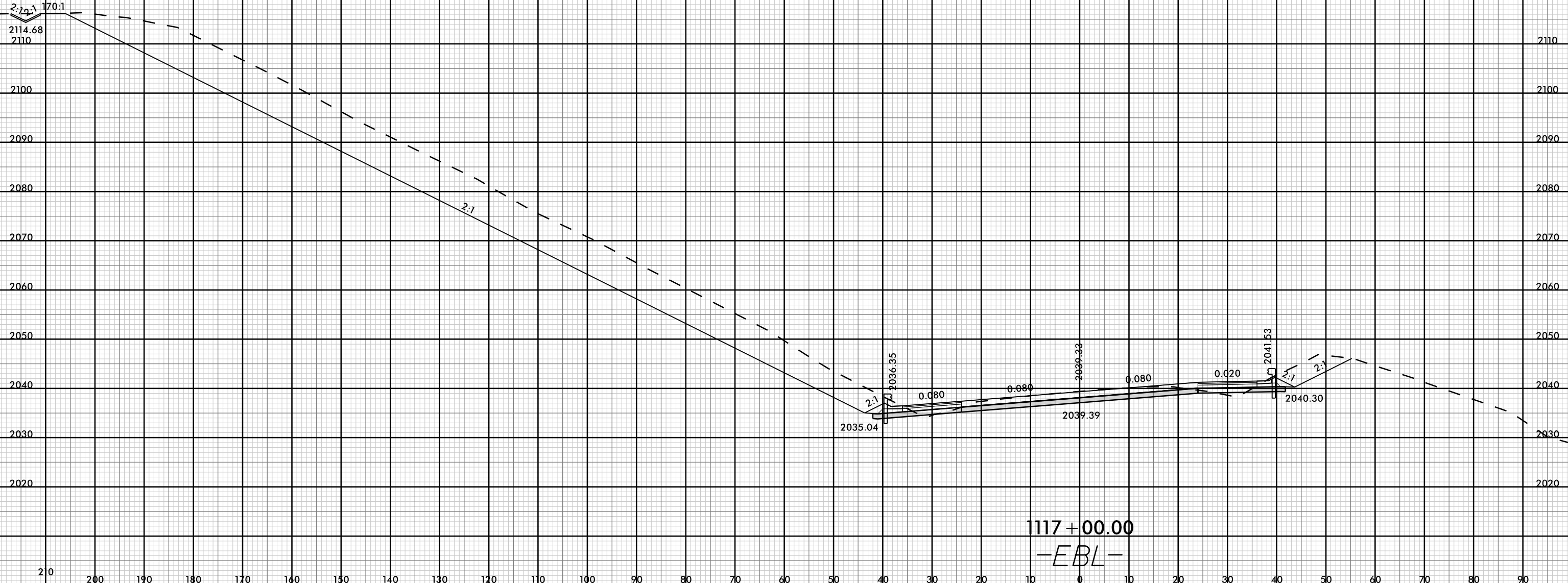



210 200 190 180 170 160 150 140 130 120 110 100 90 80 70 60 50 40 30 20 10 0 10 20 30 40 50 60 70 80 90

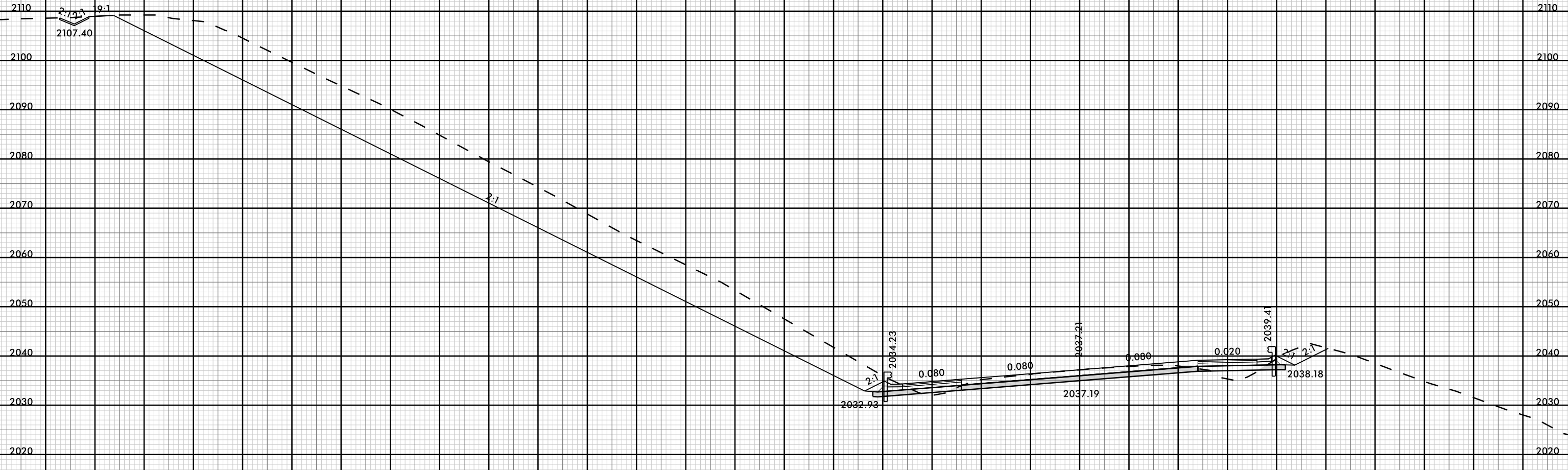

1117+50.00
-EBL-

210 200 190 180 170 160 150 140 130 120 110 100 90 80 70 60 50 40 30 20 10 0 10 20 30 40 50 60 70 80 90

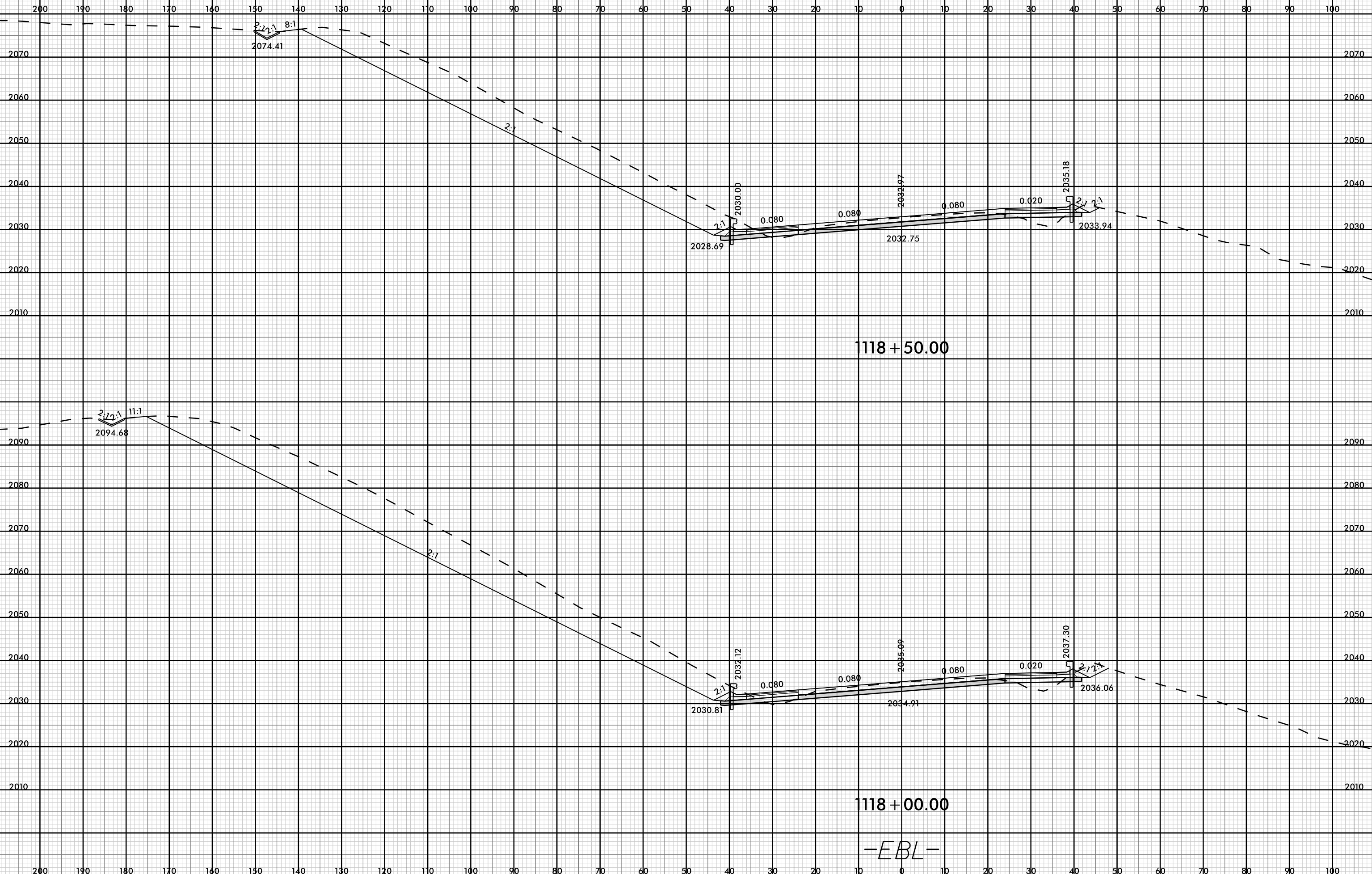
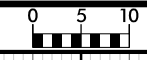

1118 + 50.00

1118 + 00.00

-EBL-

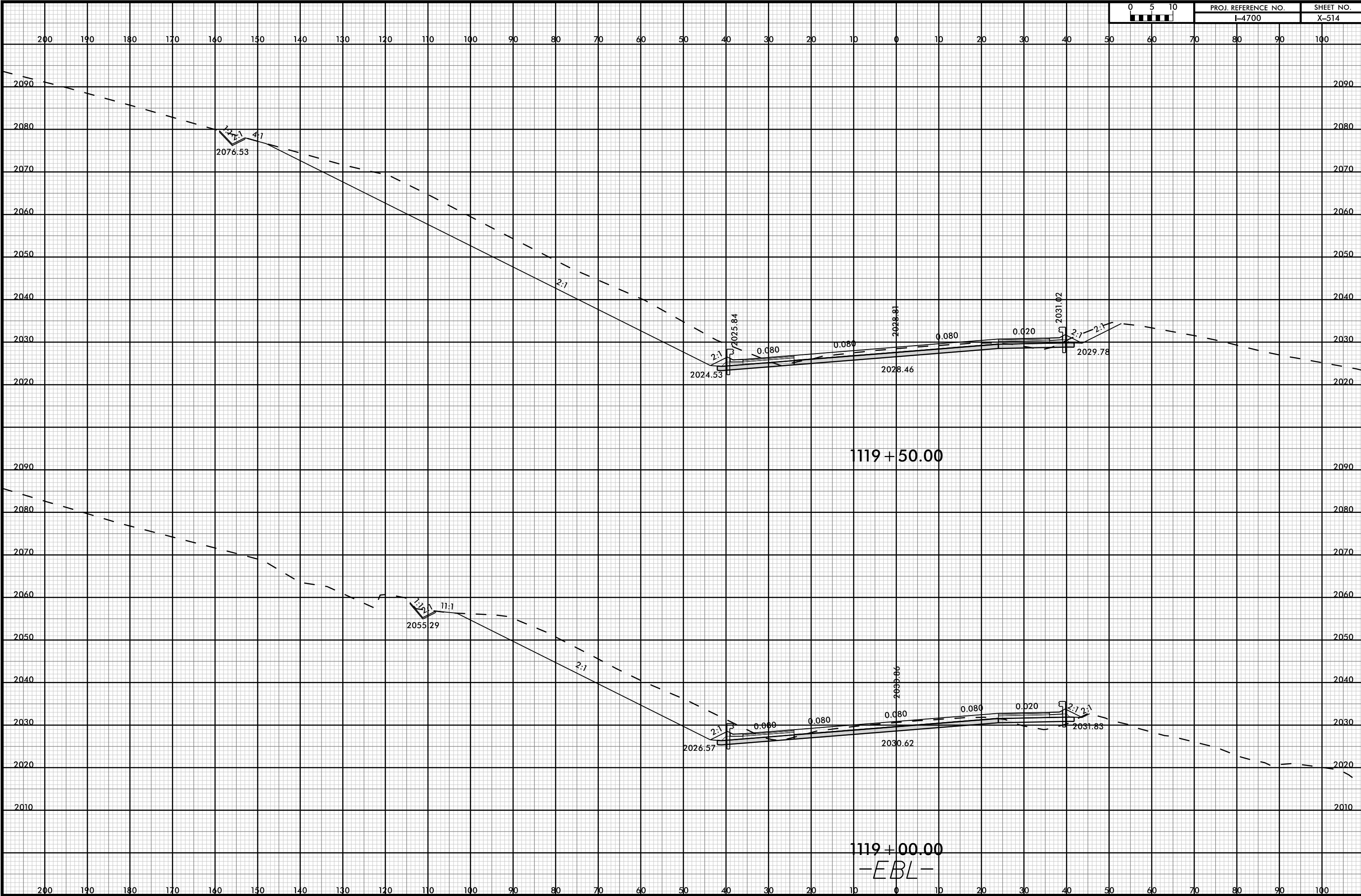
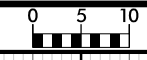



210 200 190 180 170 160 150 140 130 120 110 100 90 80 70 60 50 40 30 20 10 0 10 20 30 40 50 60 70 80 90

7A

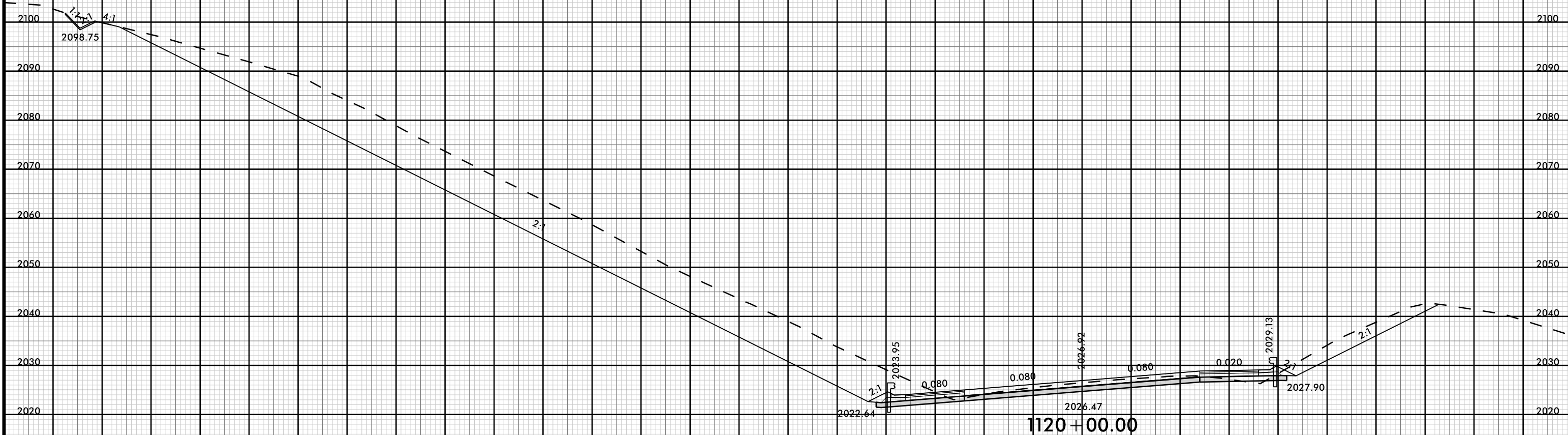

1120+00.00

-EBL-

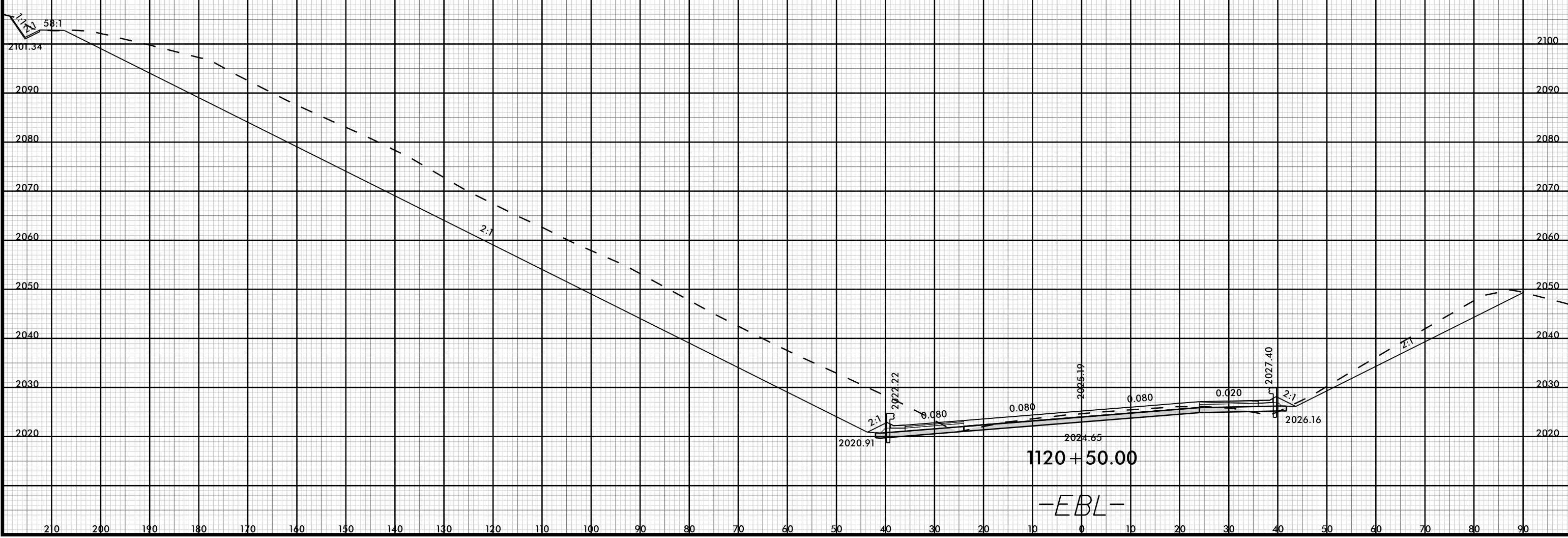
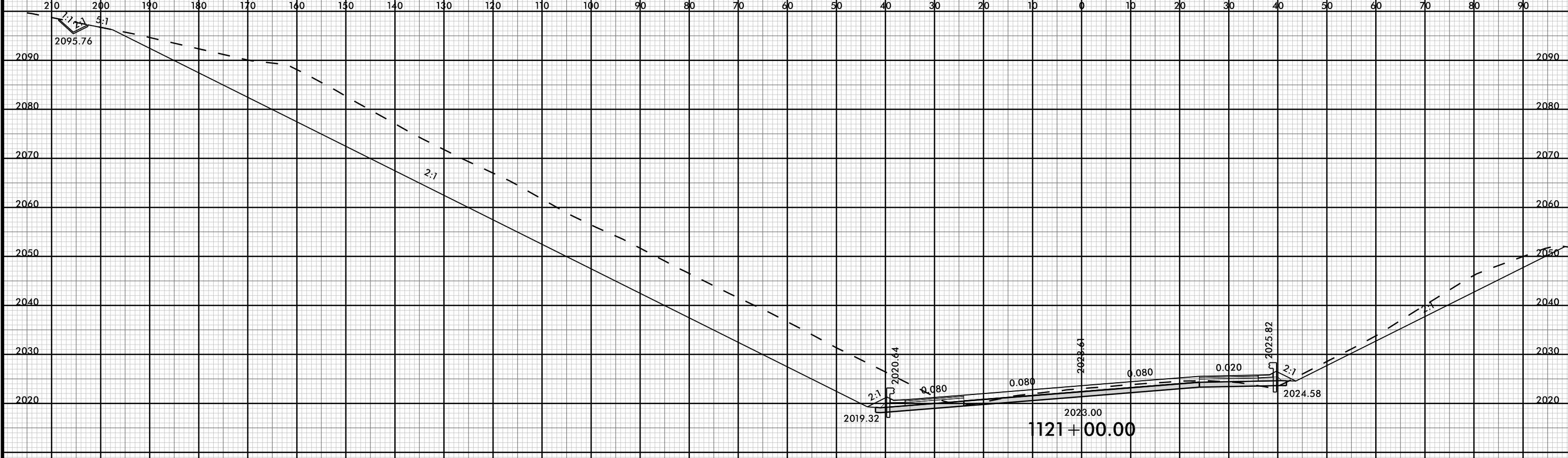
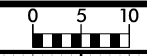

-EBL-

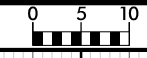

PROJ. REFERENCE NO.	SHEET NO.
I-4700	X-517

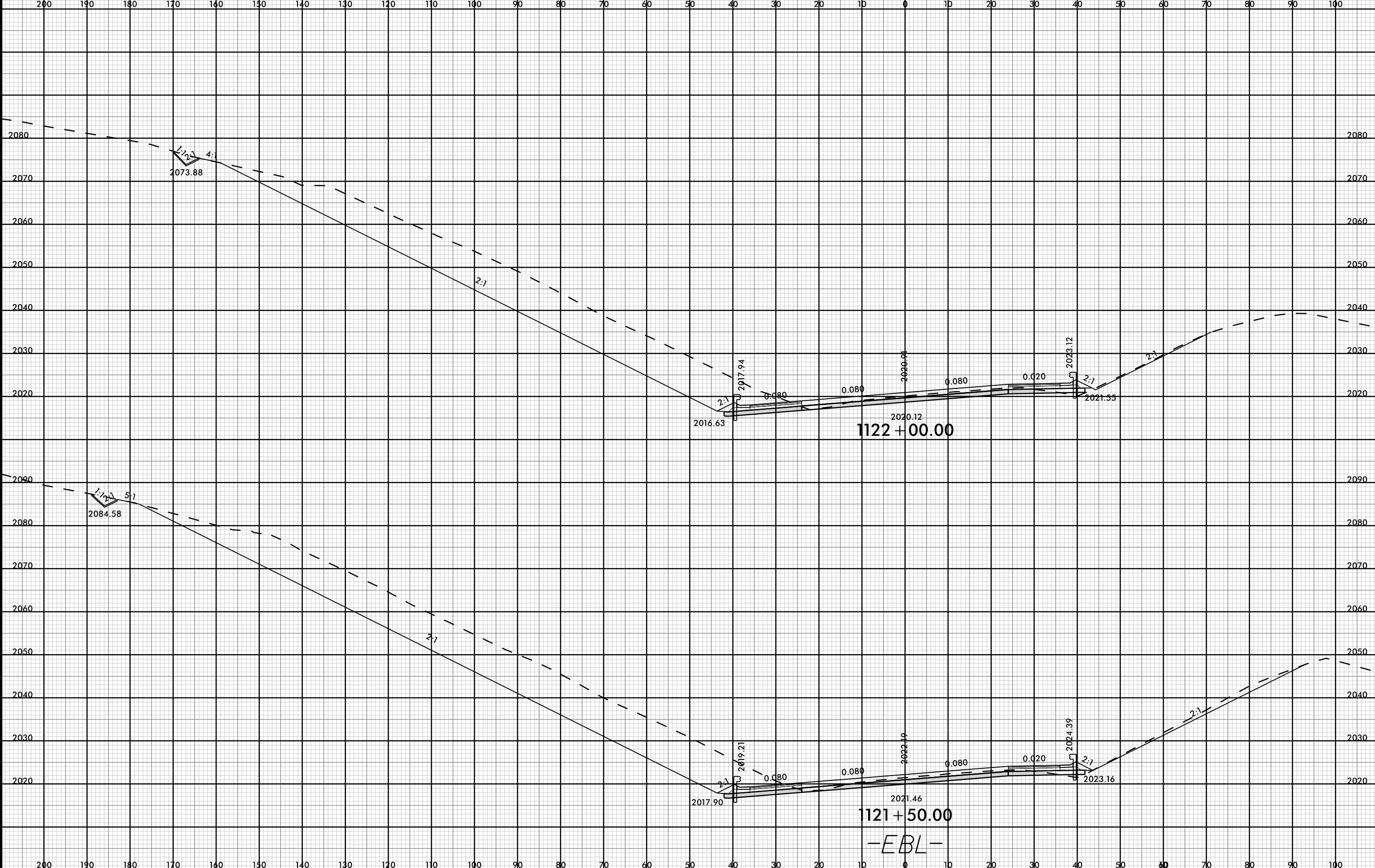

-EBL-

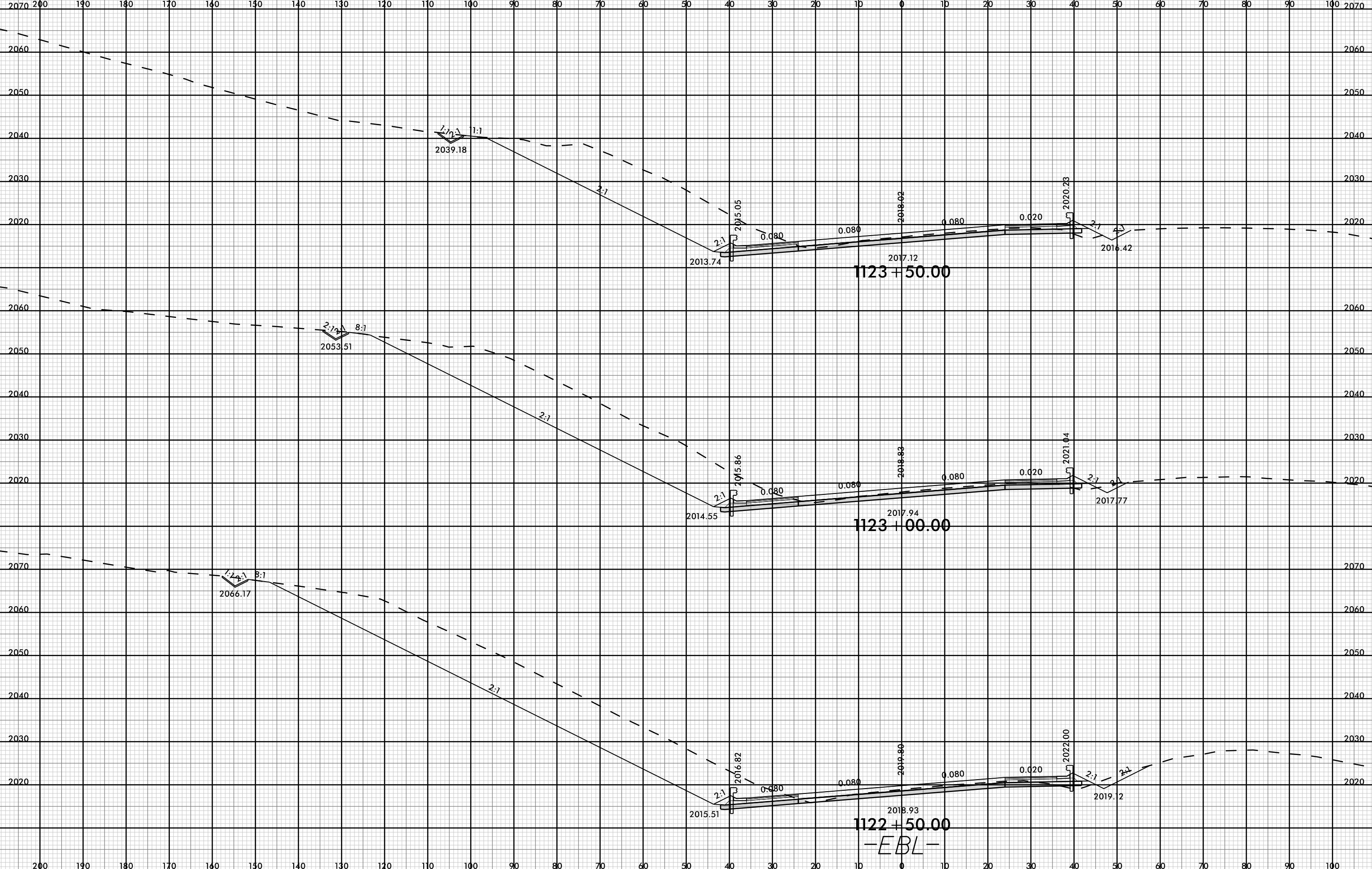

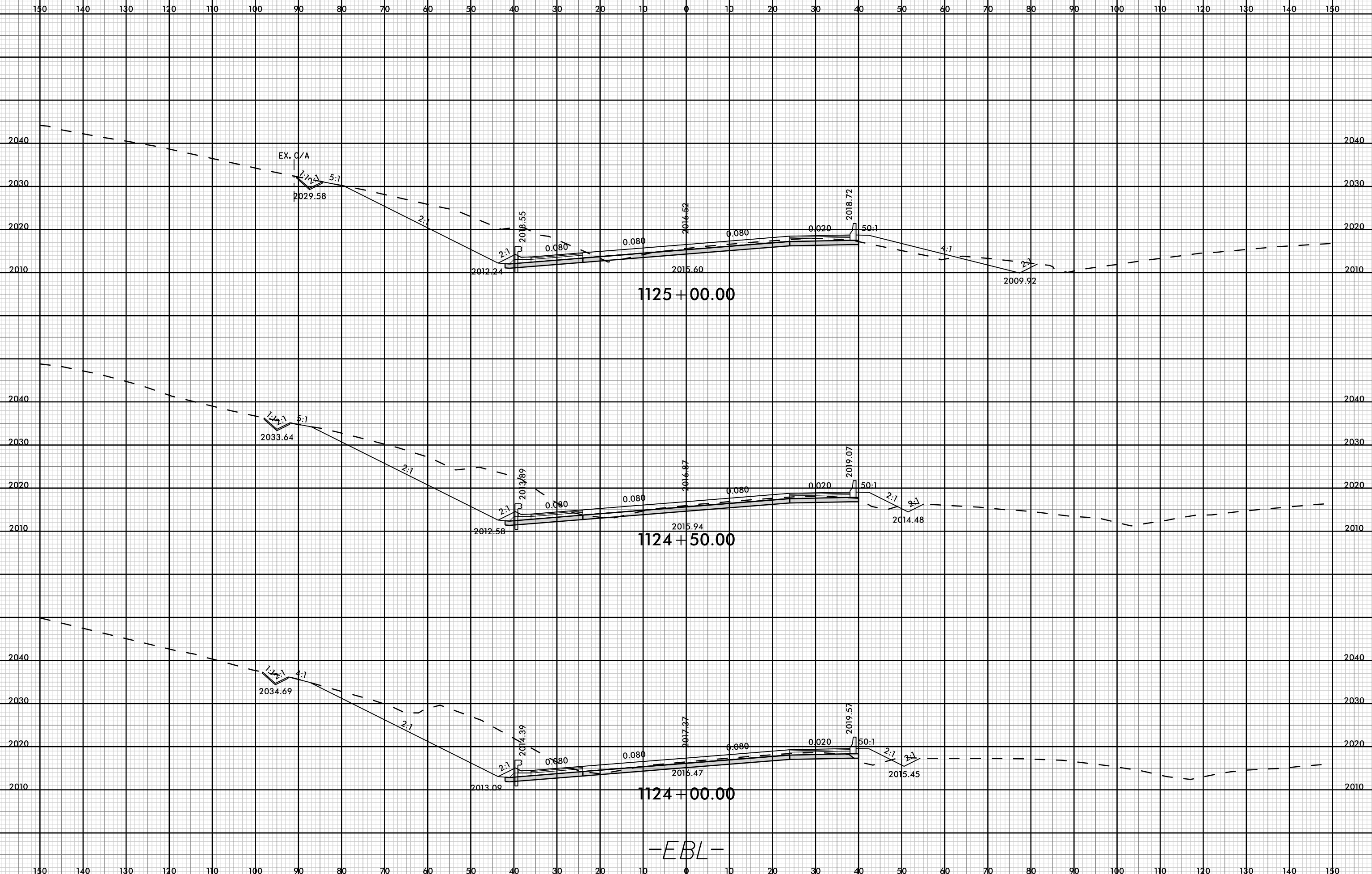

-EBL-

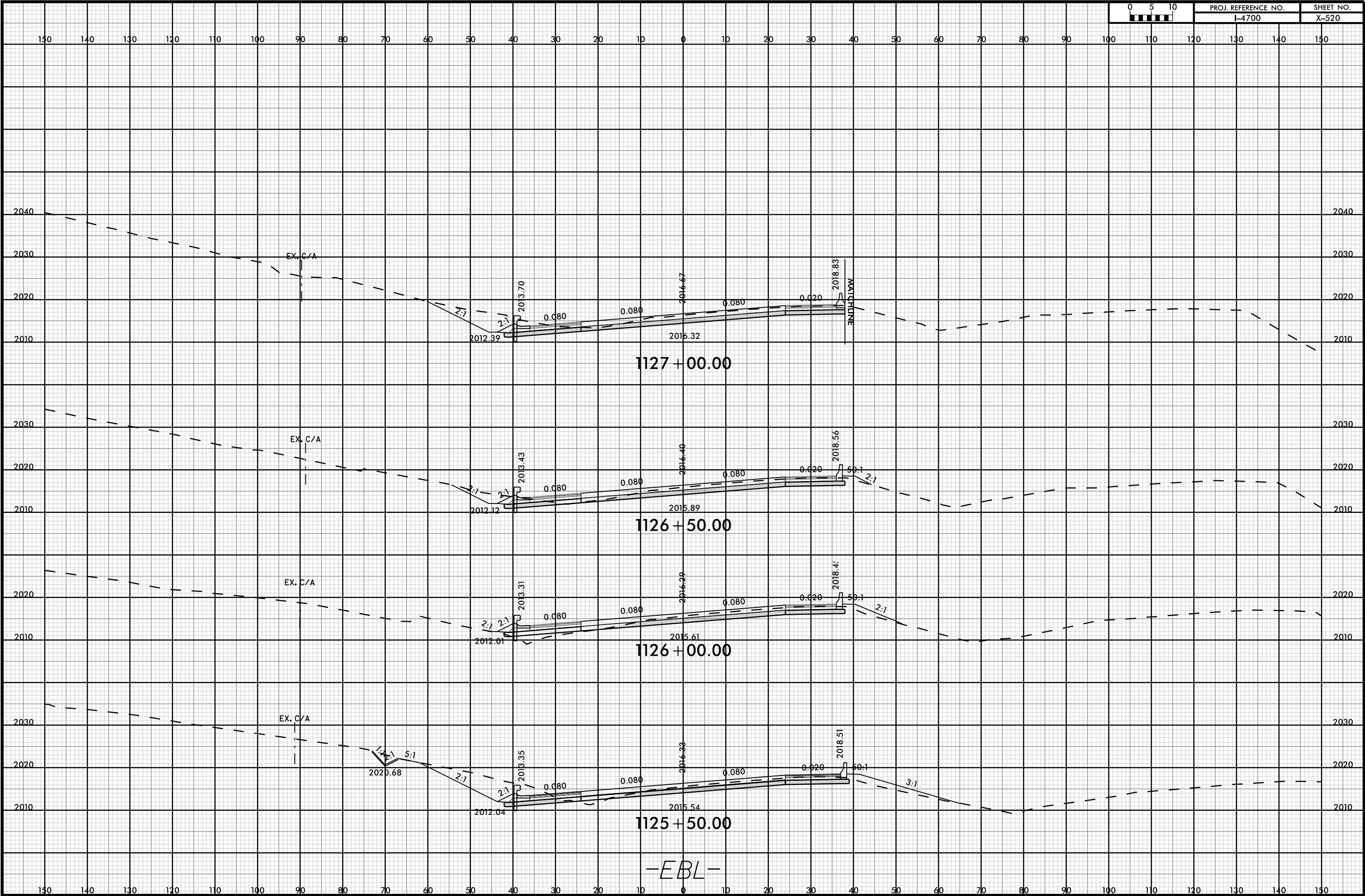

-EBL-

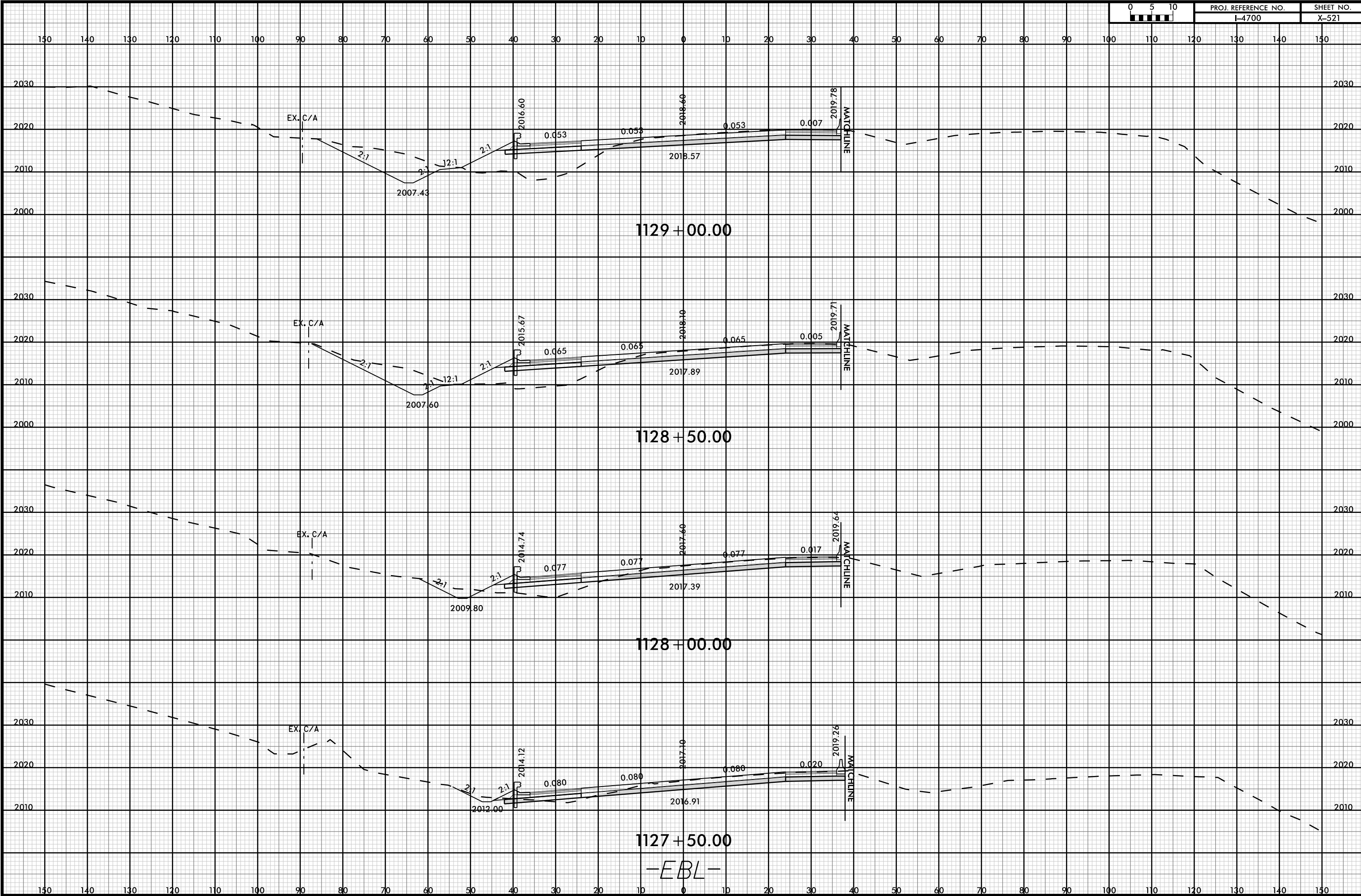



150 140 130 120 110 100 90 80 70 60 50 40 30 20 10 0 10 20 30 40 50 60 70 80 90 100 110 120 130 140 150

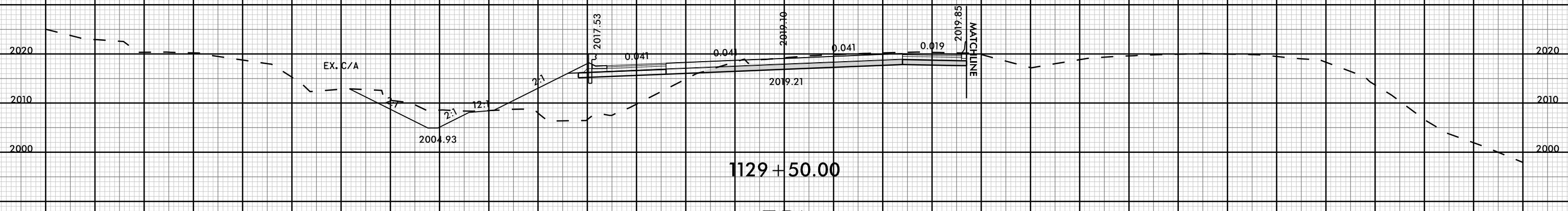
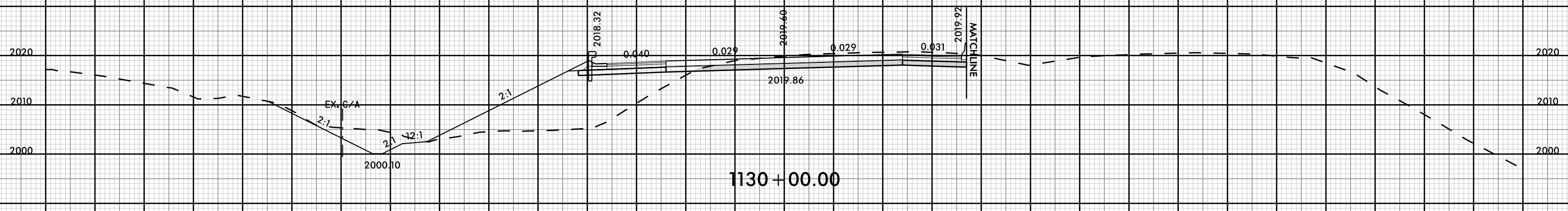
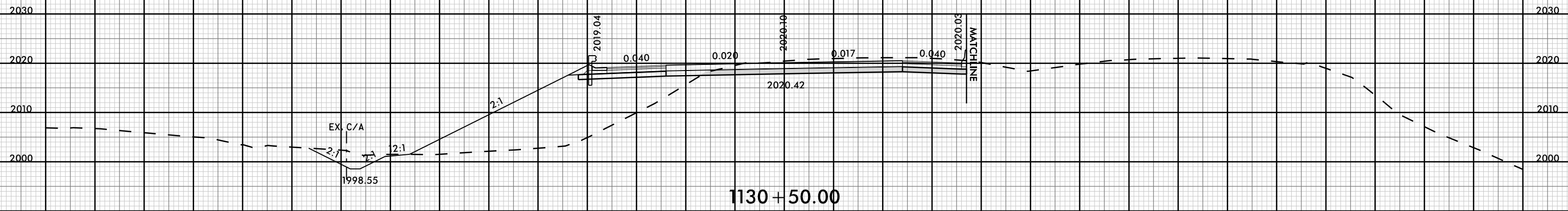

-EBL-

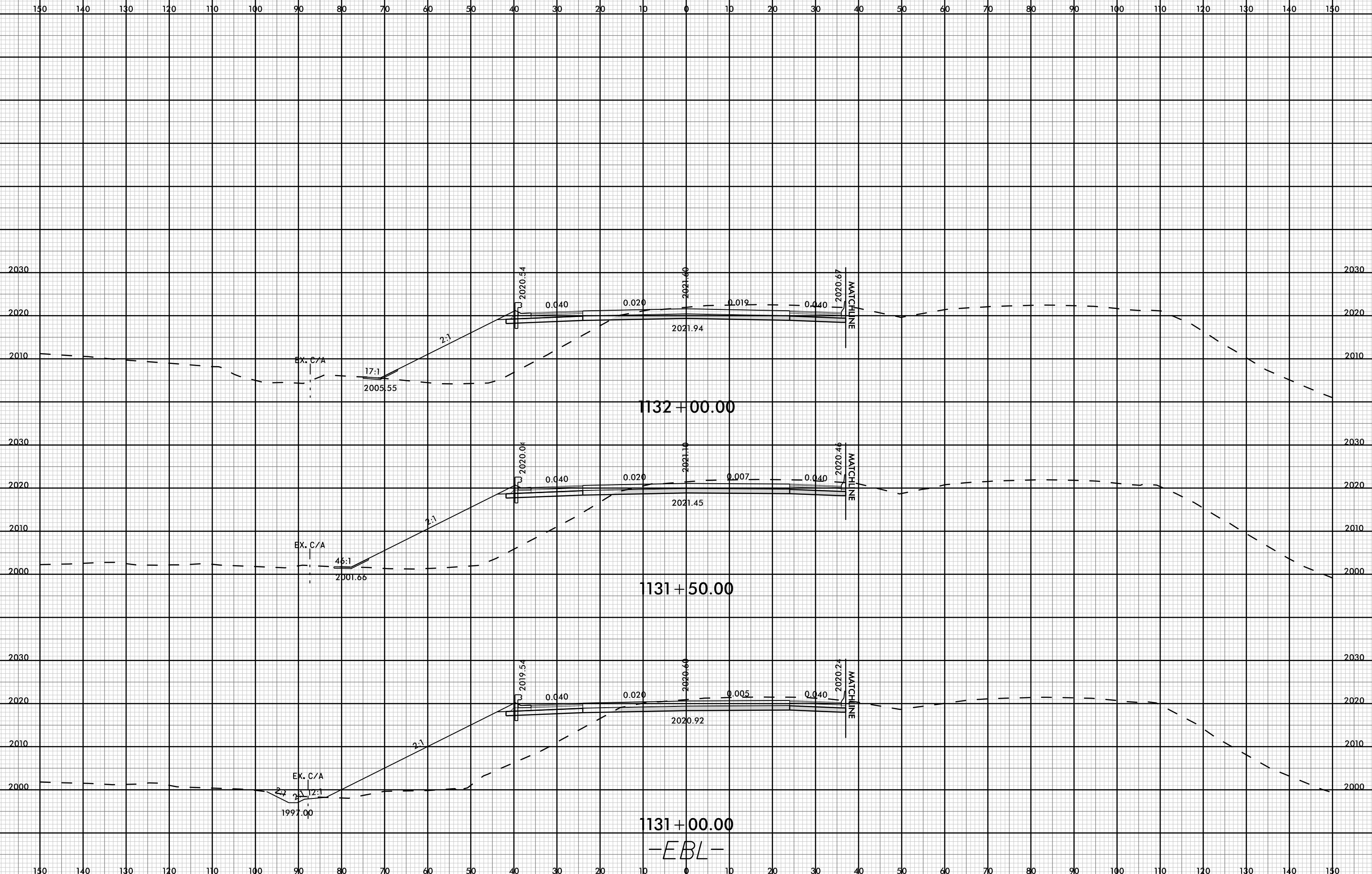

1132+00.00
1131+50.00
1131+00.00
-EBL-

8/23/99

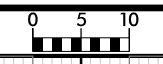

PROJ. REFERENCE NO.	SHEET NO.
I-4700	X-524

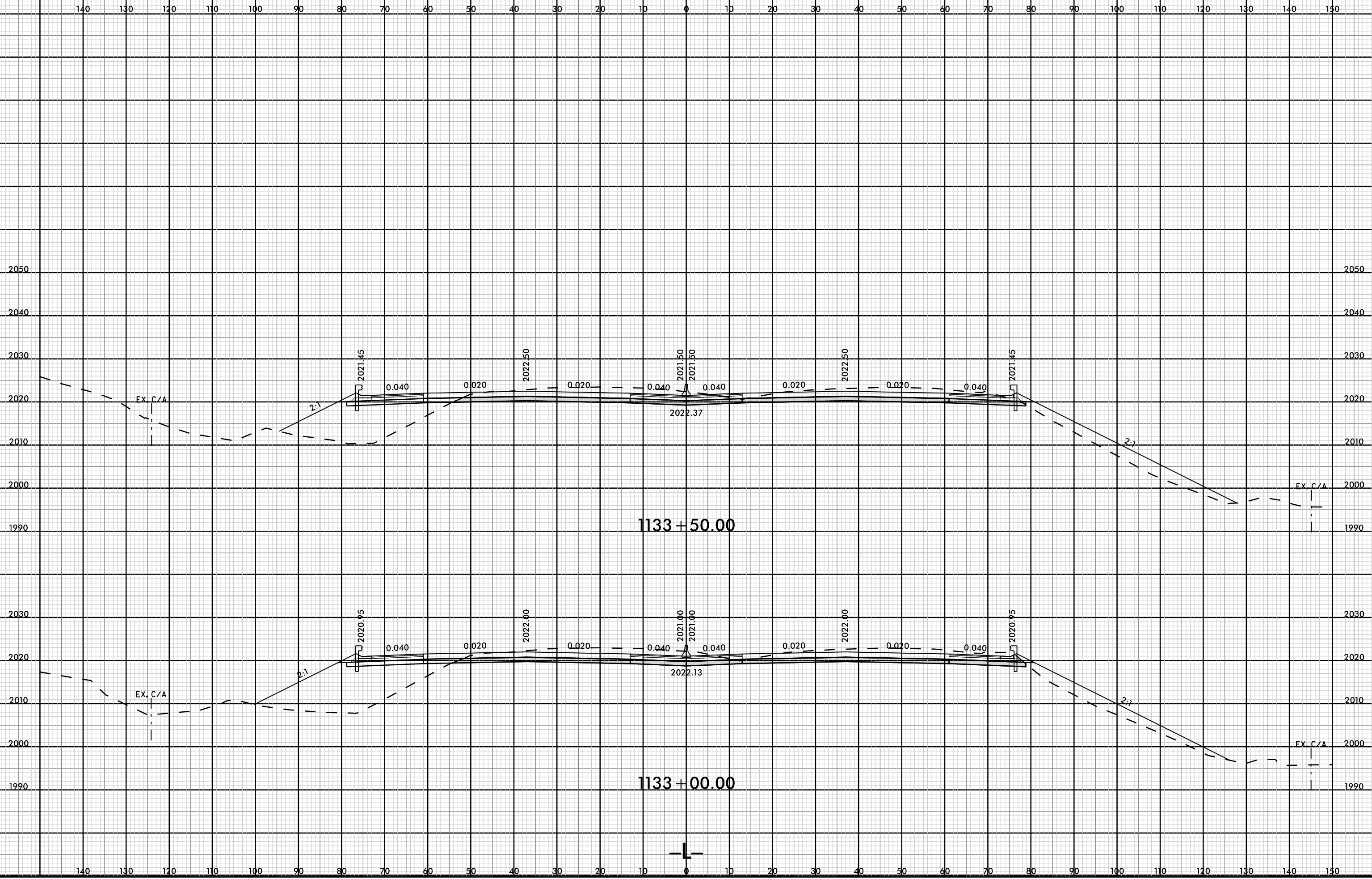

08-MAR-2019 11:52 AM
I:\4700\5-ROAD\X-524\1133.dgn



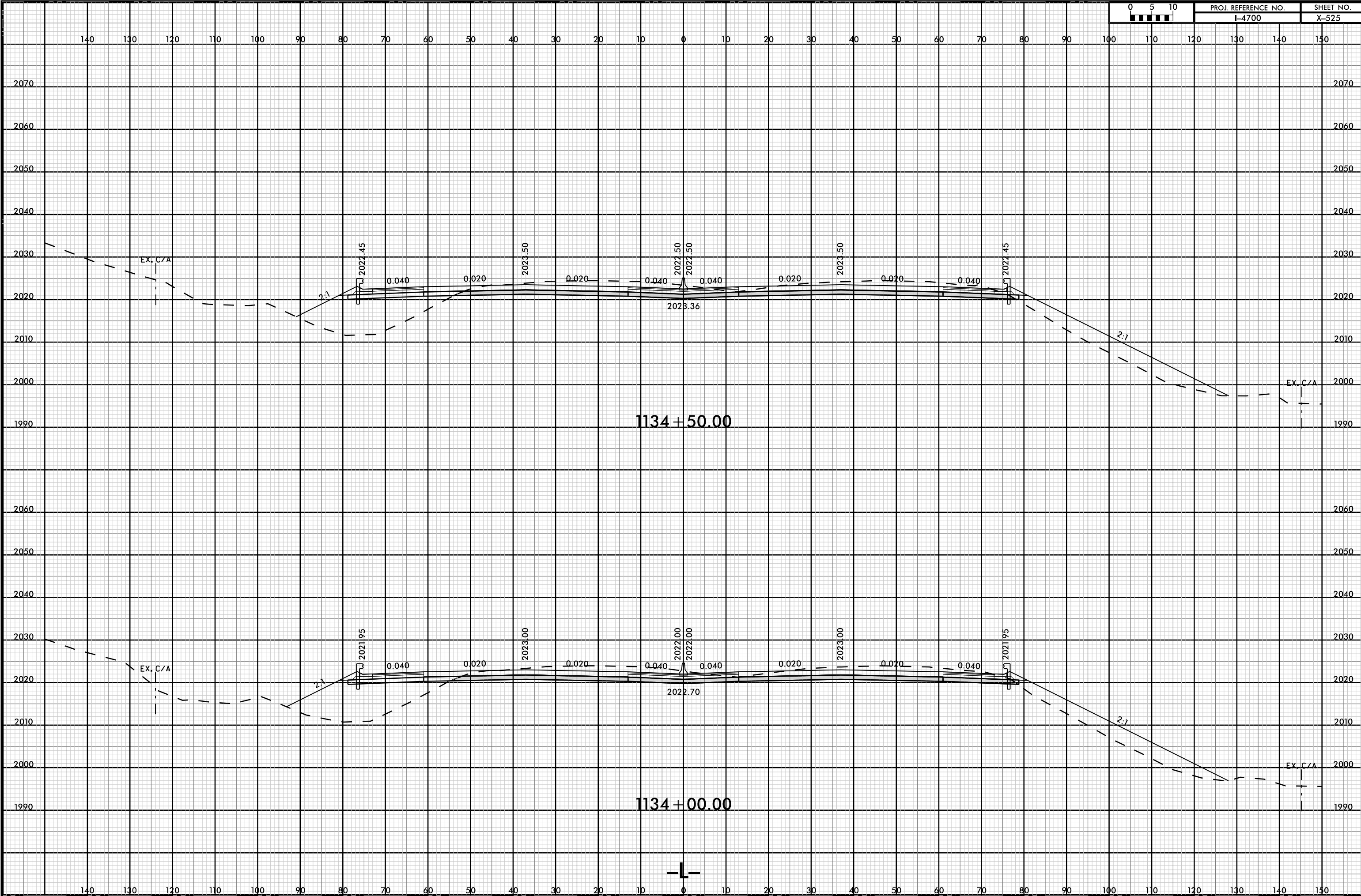

8/23/99



PROJ. REFERENCE NO.
I-4700

SHEET NO.
X-526

140 130 120 110 100 90 80 70 60 50 40 30 20 10 0 10 20 30 40 50 60 70 80 90 100 110 120 130 140 150

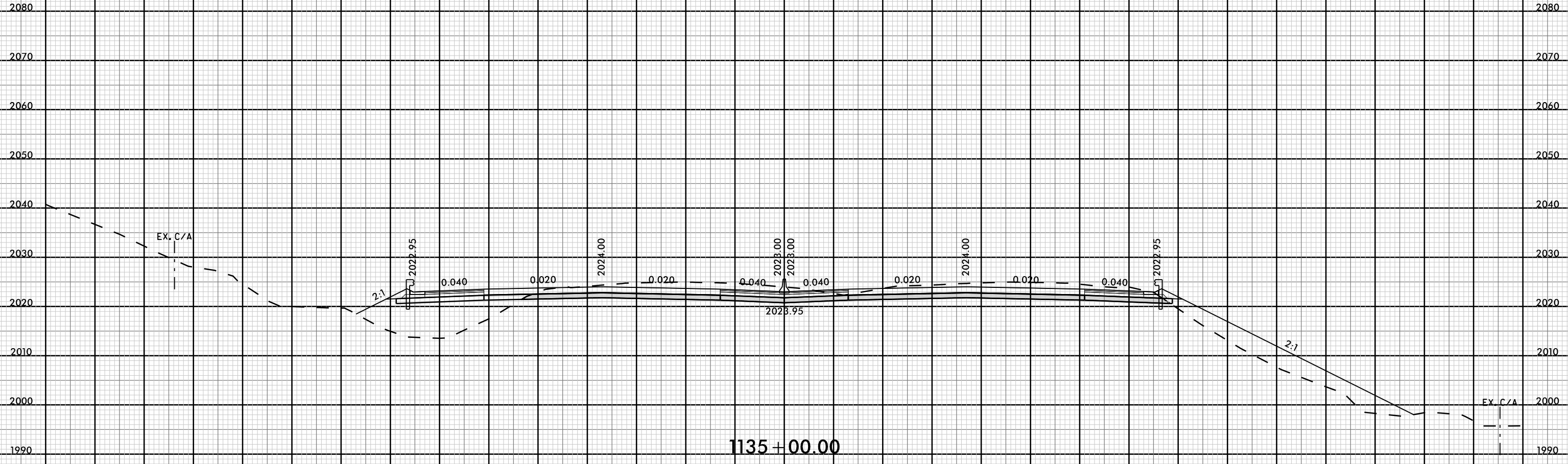

08-MAR-2019 11:53
I-4700-FOY-XFL.L3.dgn
FNITB



140 130 120 110 100 90 80 70 60 50 40 30 20 10 0 10 20 30 40 50 60 70 80 90 100 110 120 130 140 150

8/23/99

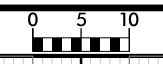

PROJ. REFERENCE NO.	SHEET NO.
I-4700	X-527

140 130 120 110 100 90 80 70 60 50 40 30 20 10 0 10 20 30 40 50 60 70 80 90 100 110 120 130 140 150

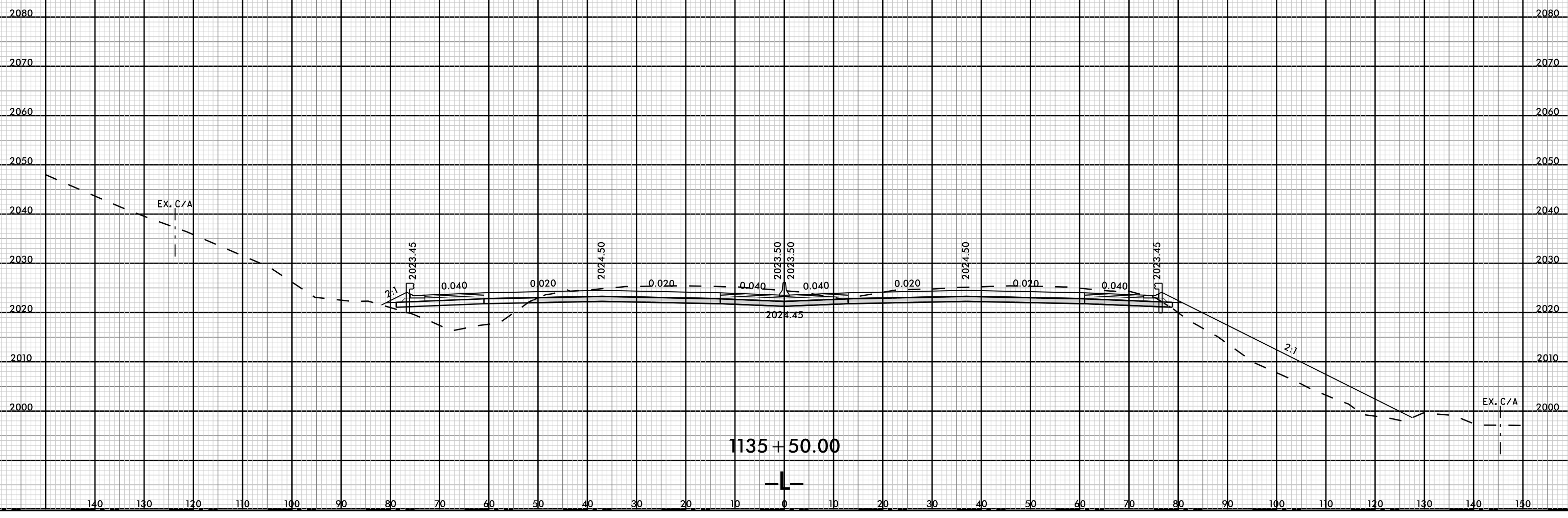

08-MAR-2019 11:53
 I4700S-ROV-XPL.L3.dgn
 FNITB

8/23/99



PROJ. REFERENCE NO.
I-4700

SHEET NO.
X-528

140 130 120 110 100 90 80 70 60 50 40 30 20 10 0 10 20 30 40 50 60 70 80 90 100 110 120 130 140 150

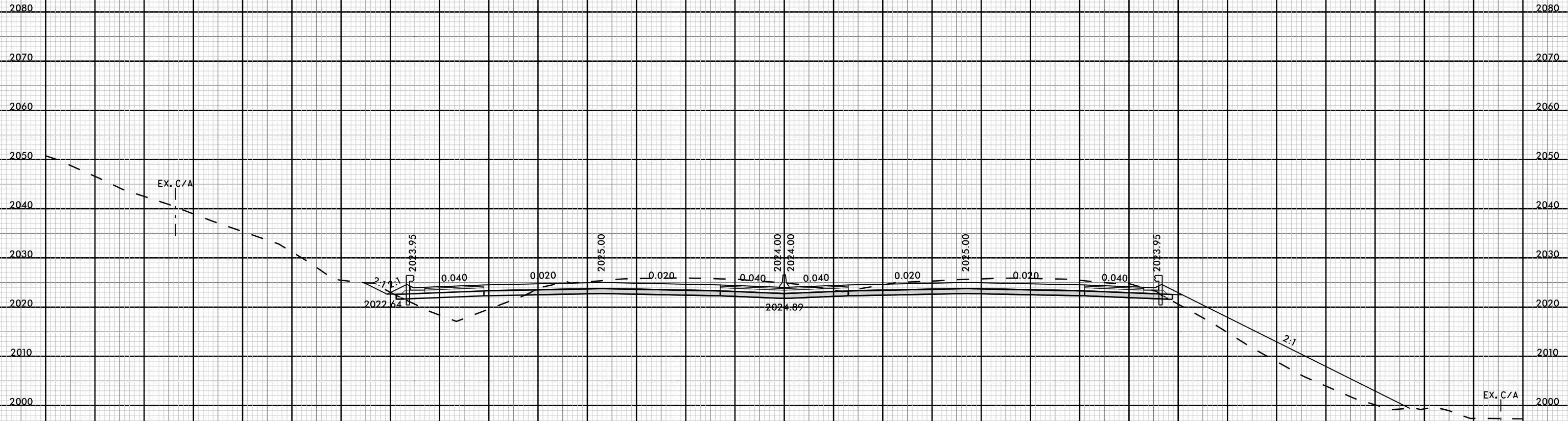

1136 + 00.00



08-MAR-2019 11:53
I-4700-FOY-XPL.L3.dgn
FNITB

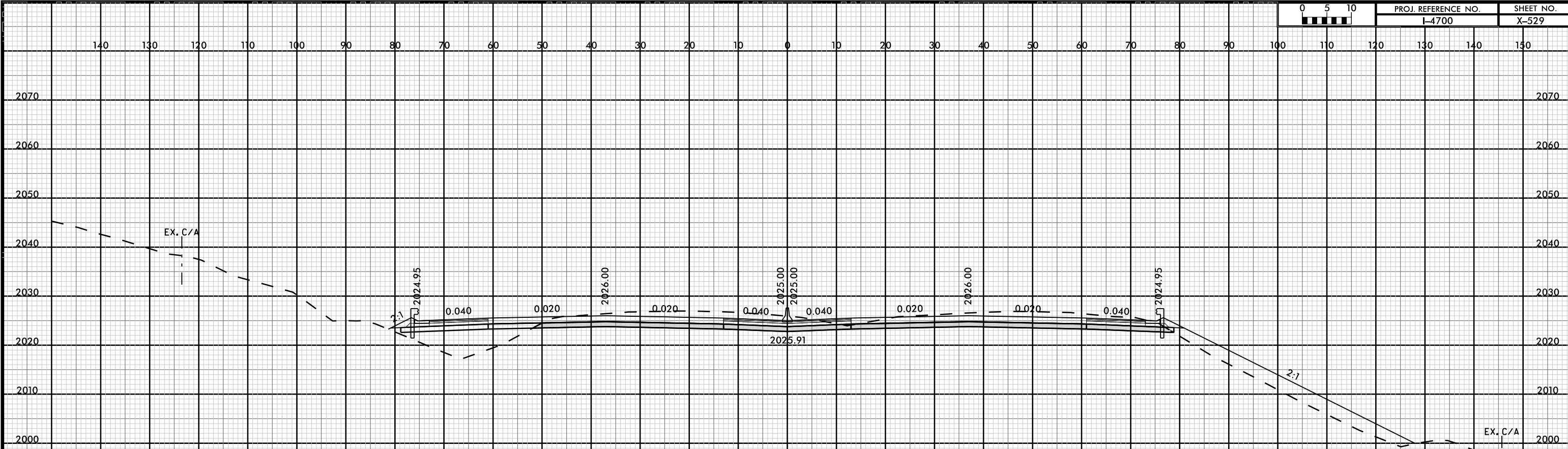

1137+00.00

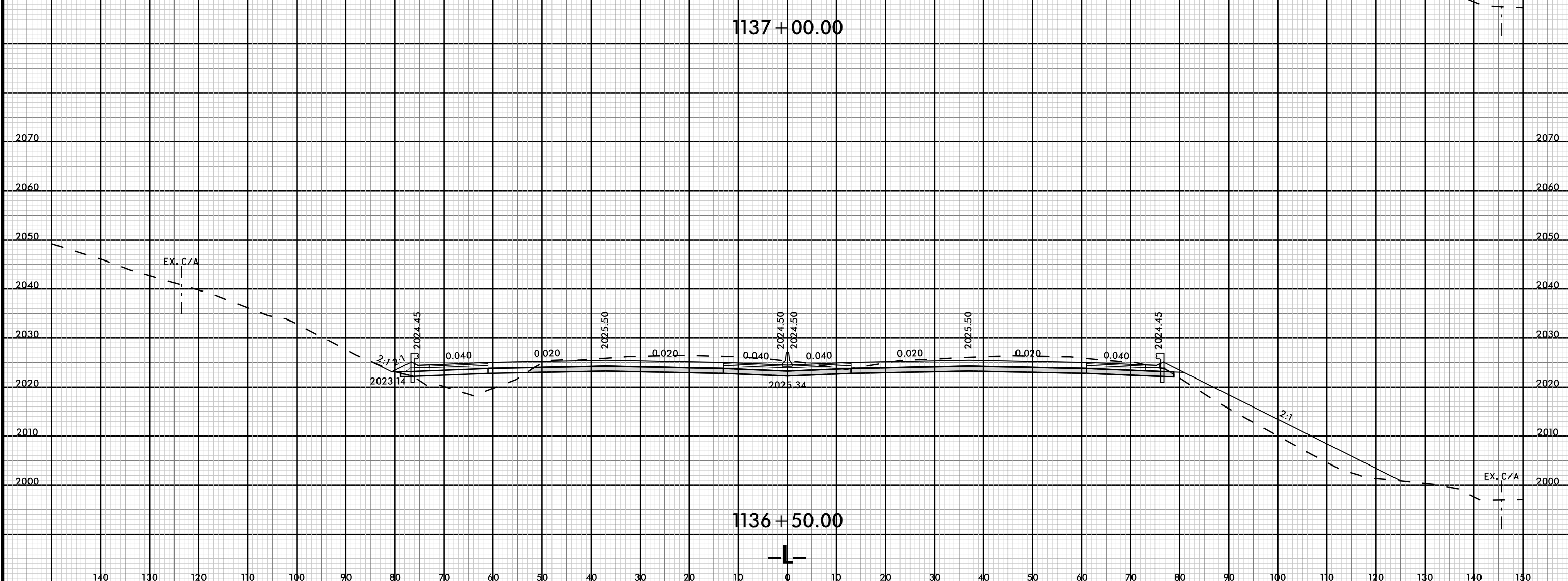

1136+50.00

8/23/99

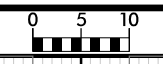

PROJ. REFERENCE NO.	SHEET NO.
I-4700	X-530

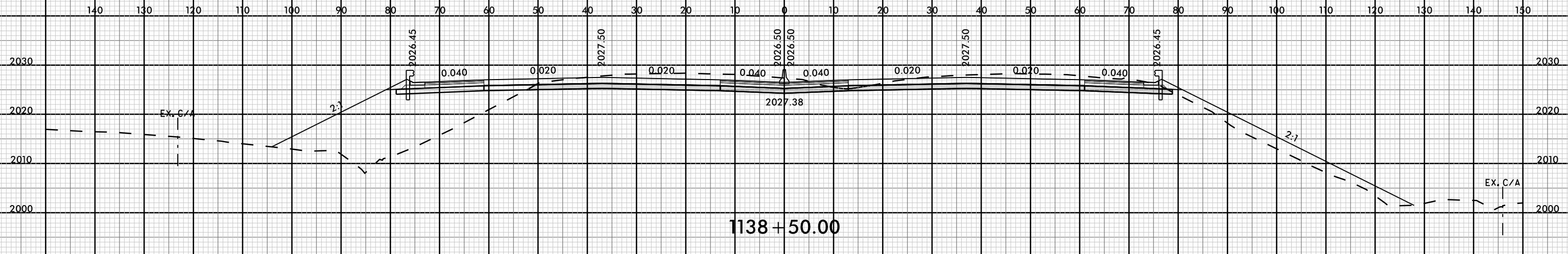

1138 + 50.00

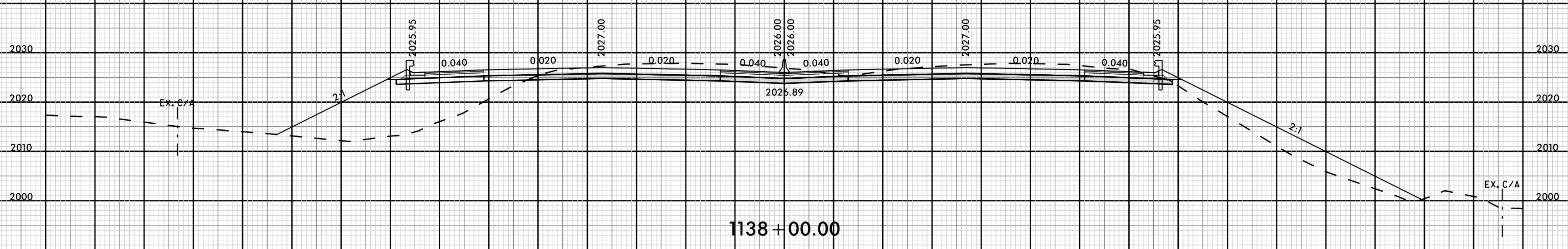

1138 + 00.00

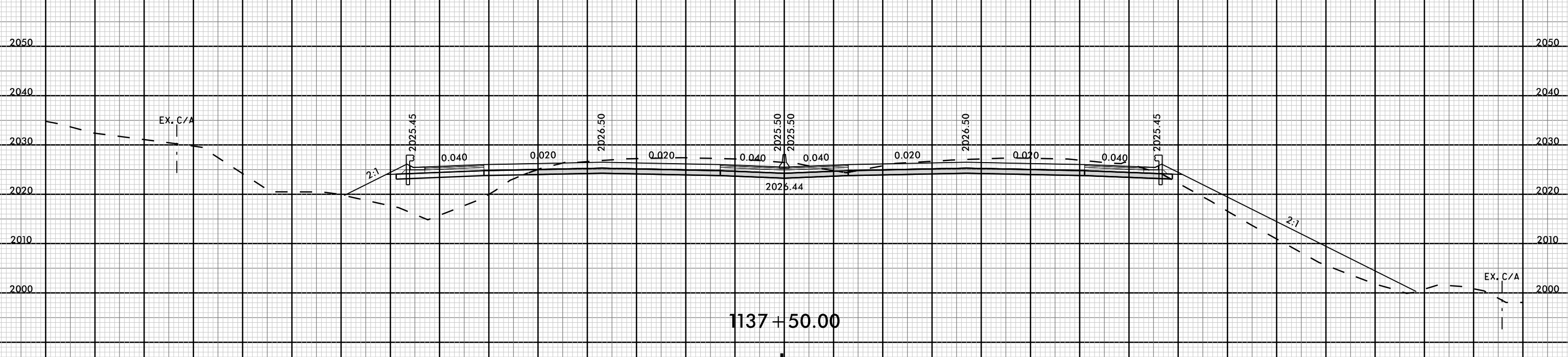

1137 + 50.00

08-MAR-2019 11:53 AM
I-4700-X-530-FL-3.dgn



8/23/99



PROJ. REFERENCE NO.
I-4700

SHEET NO.
X-531

140 130 120 110 100 90 80 70 60 50 40 30 20 10 0 10 20 30 40 50 60 70 80 90 100 110 120 130 140 150

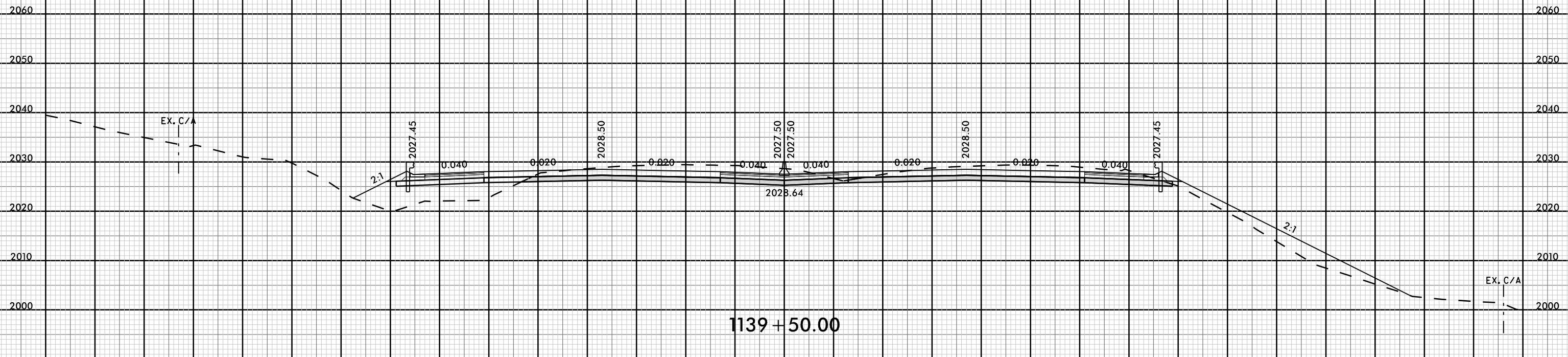

1139 + 50.00

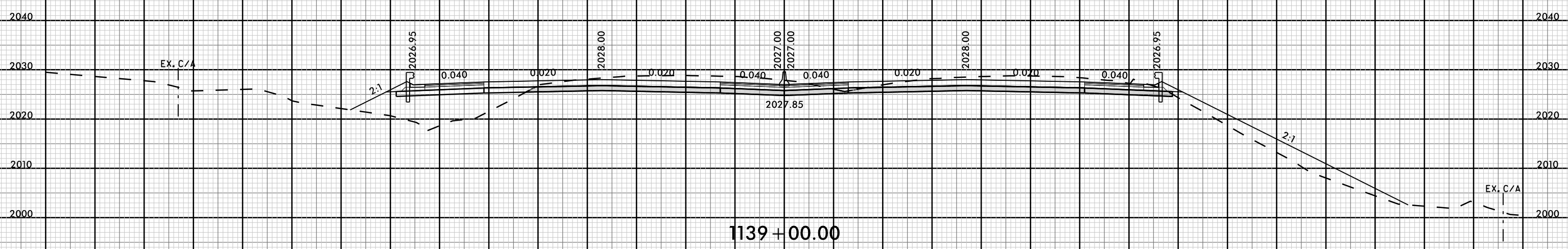

1139 + 00.00

08-MAR-2009 11:53
I-4700B-ROD-XPL.L3.dgn
FNITB

140 130 120 110 100 90 80 70 60 50 40 30 20 10 0 10 20 30 40 50 60 70 80 90 100 110 120 130 140 150

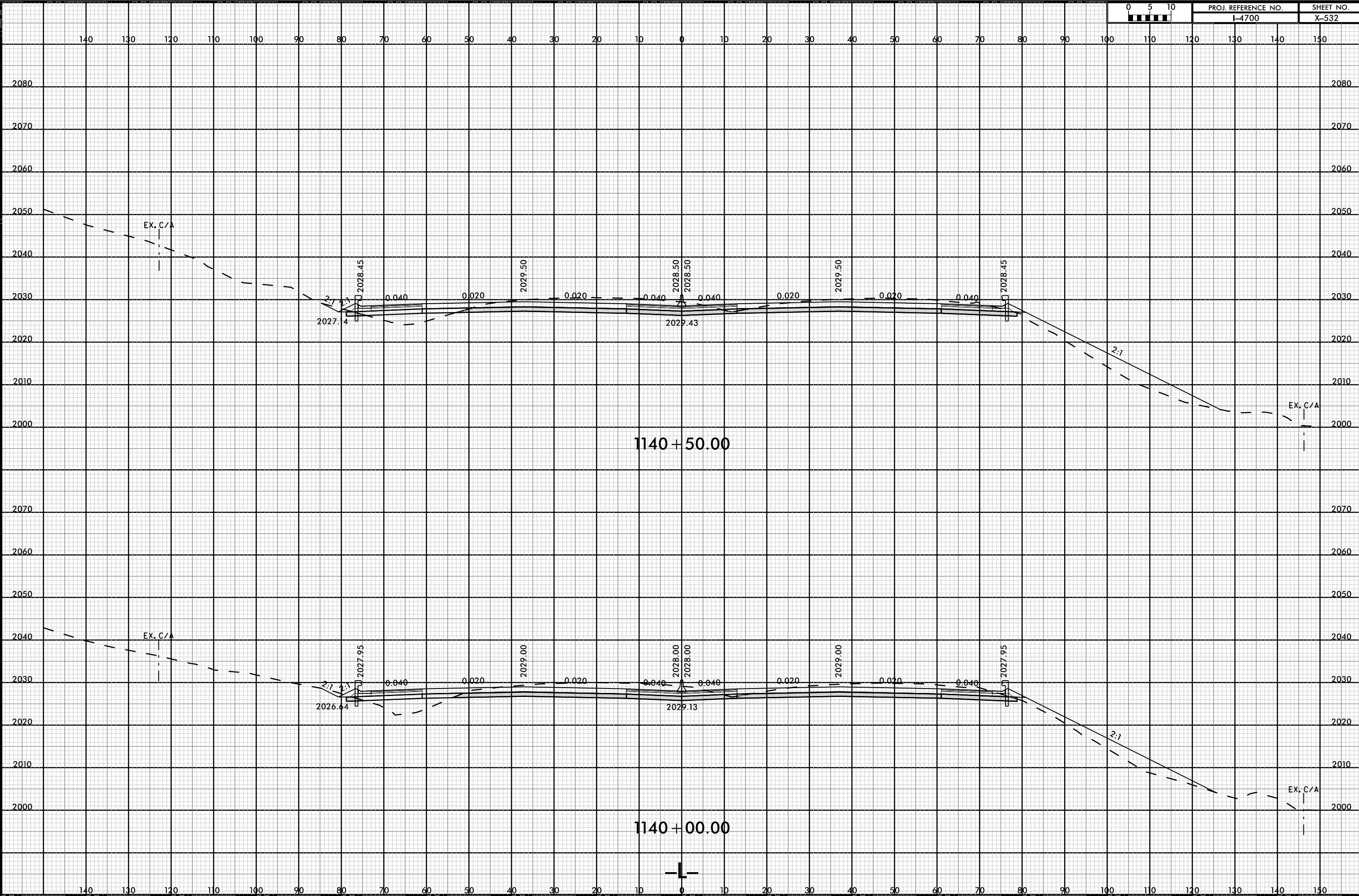

8/23/99



PROJ. REFERENCE NO.
I-4700

SHEET NO.
X-533

140 130 120 110 100 90 80 70 60 50 40 30 20 10 0 10 20 30 40 50 60 70 80 90 100 110 120 130 140 150

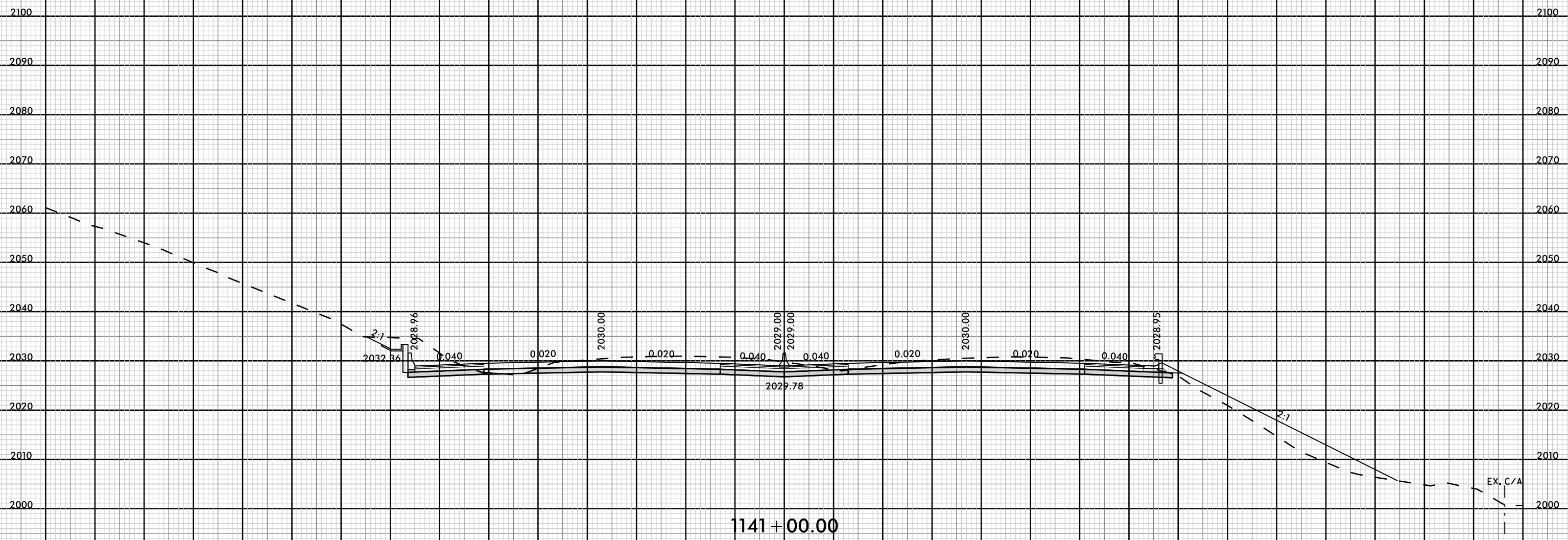

08-MAR-2019 11:53
I-4700-X-533-PL-1.dgn

EX. C/A

1141+00.00

8/23/99



PROJ. REFERENCE NO.	SHEET NO.
I-4700	X-534

140 130 120 110 100 90 80 70 60 50 40 30 20 10 0 10 20 30 40 50 60 70 80 90 100 110 120 130 140 150

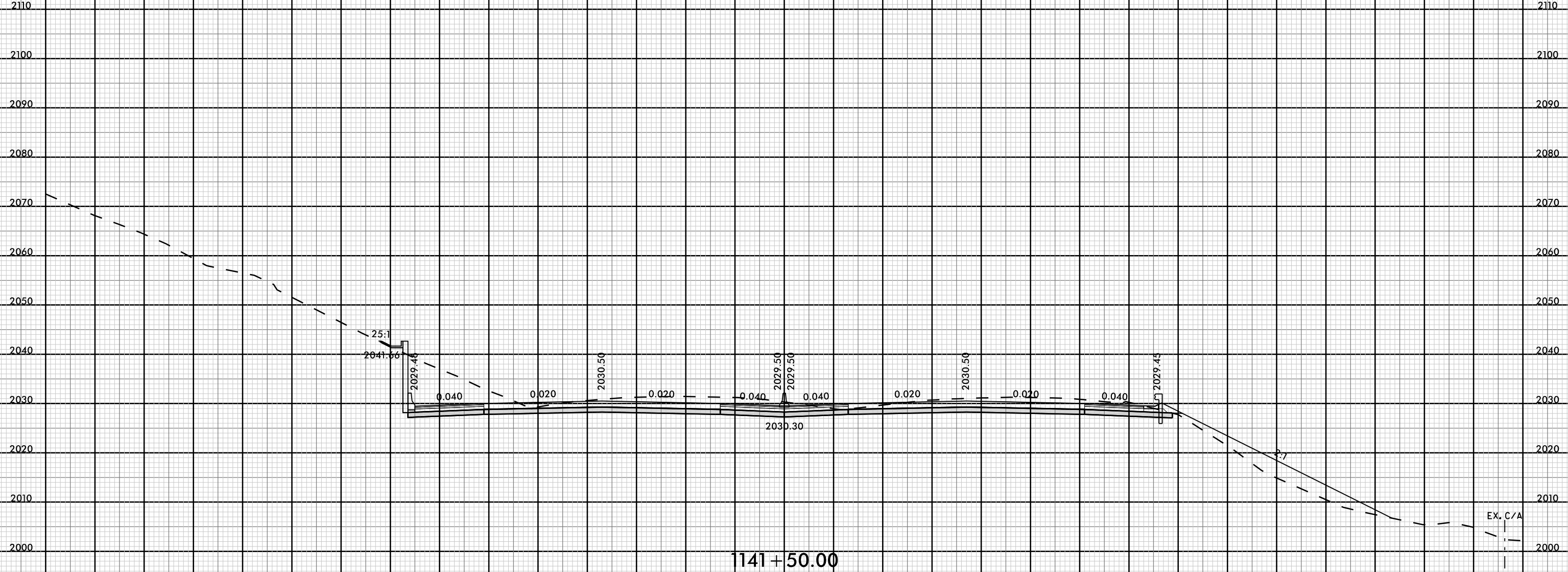

1141 + 50.00

EX. C/A

08-MAR-2019 11:54 AM
 I:\470005-ROV-XPL-L-3.dgn
 FNITB

8/23/99

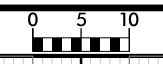

PROJ. REFERENCE NO.	SHEET NO.
I-4700	X-535

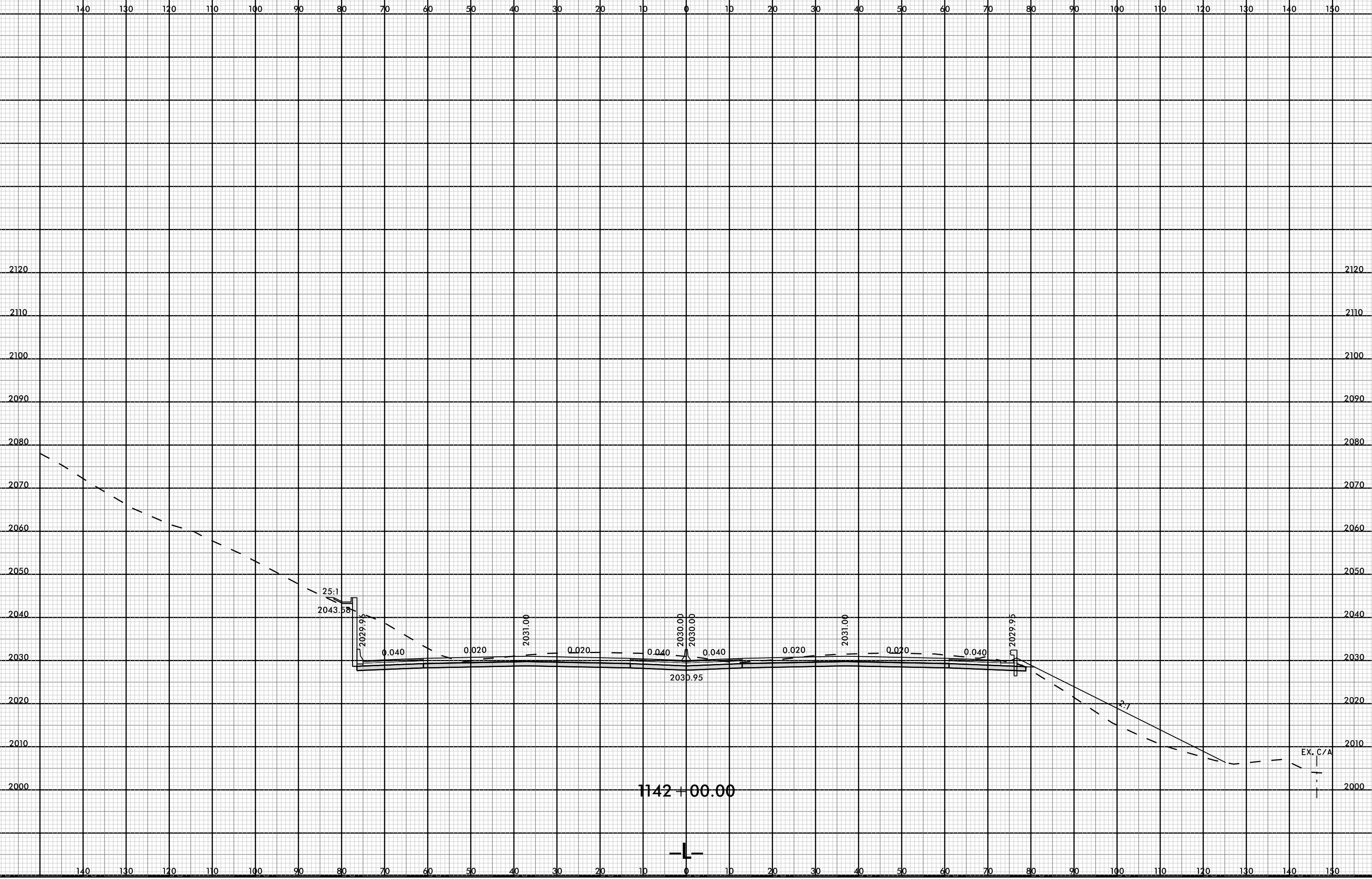

08-MAR-2019 11:54 AM
I:\4700\B-ROAD-XPL-L-3.dgn
FNITB



8/23/99



PROJ. REFERENCE NO.
I-4700

SHEET NO.
X-536

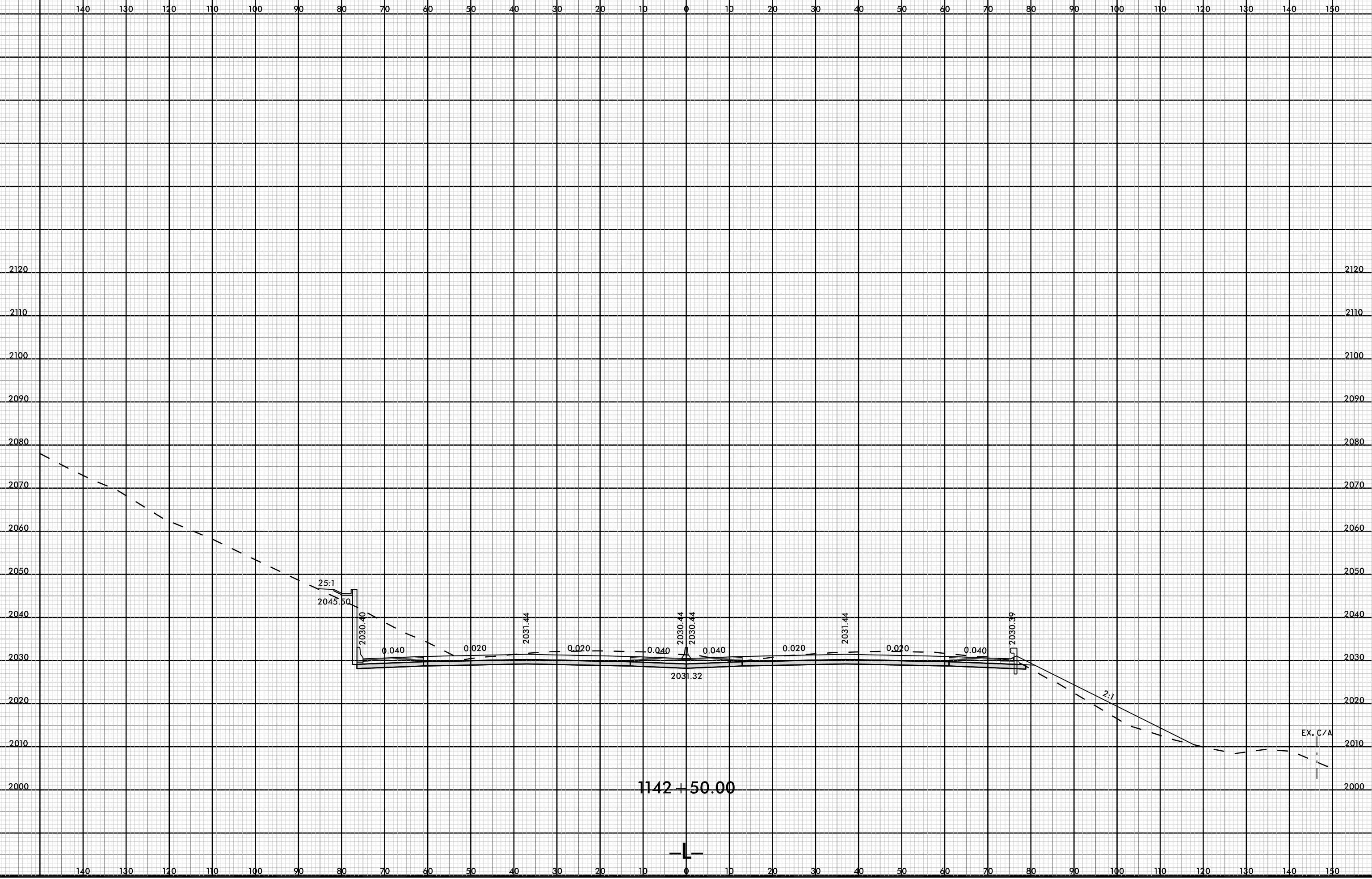

1142 + 50.00

EX. C/A

08-MAR-2009 11:54 AM
 I:\4700\B-ROAD-XPL-L-3.dgn
 FNITB



140 130 120 110 100 90 80 70 60 50 40 30 20 10 0 10 20 30 40 50 60 70 80 90 100 110 120 130 140 150

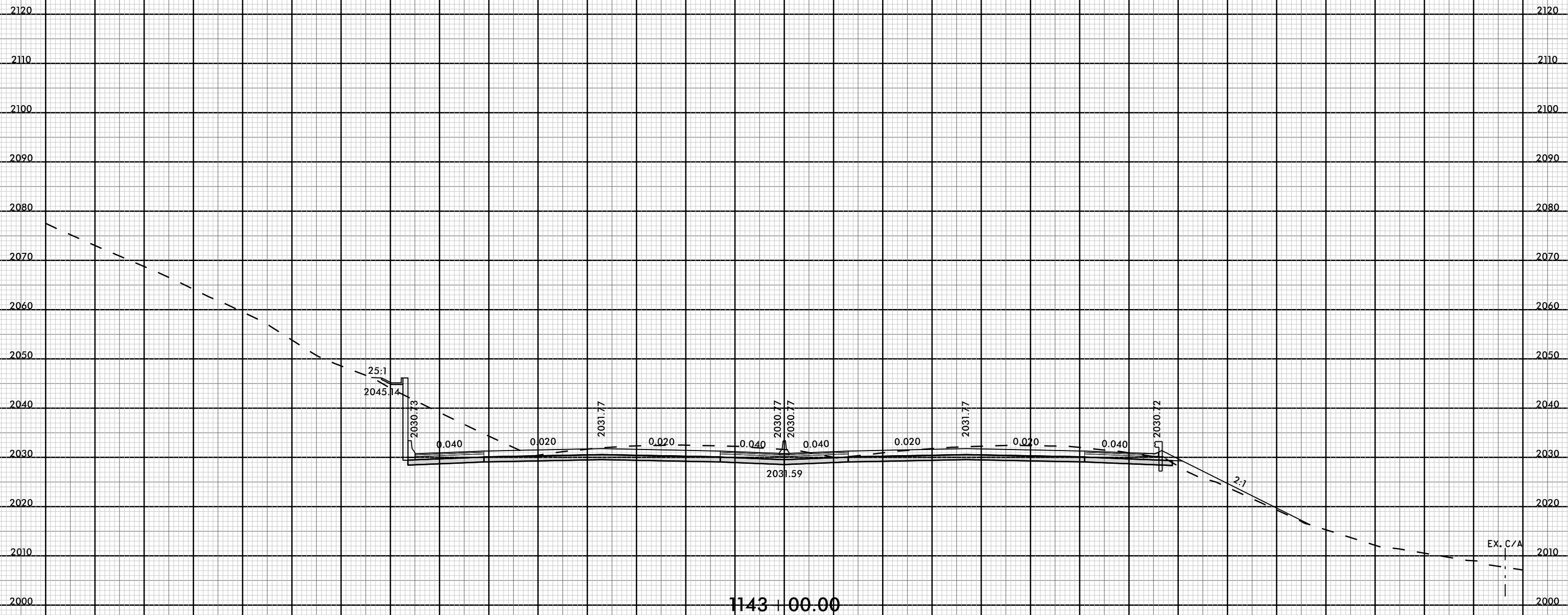

1143 | 00.00

EX. C/A

8/23/99



PROJ. REFERENCE NO.
I-4700

SHEET NO.
X-538

140 130 120 110 100 90 80 70 60 50 40 30 20 10 0 10 20 30 40 50 60 70 80 90 100 110 120 130 140 150

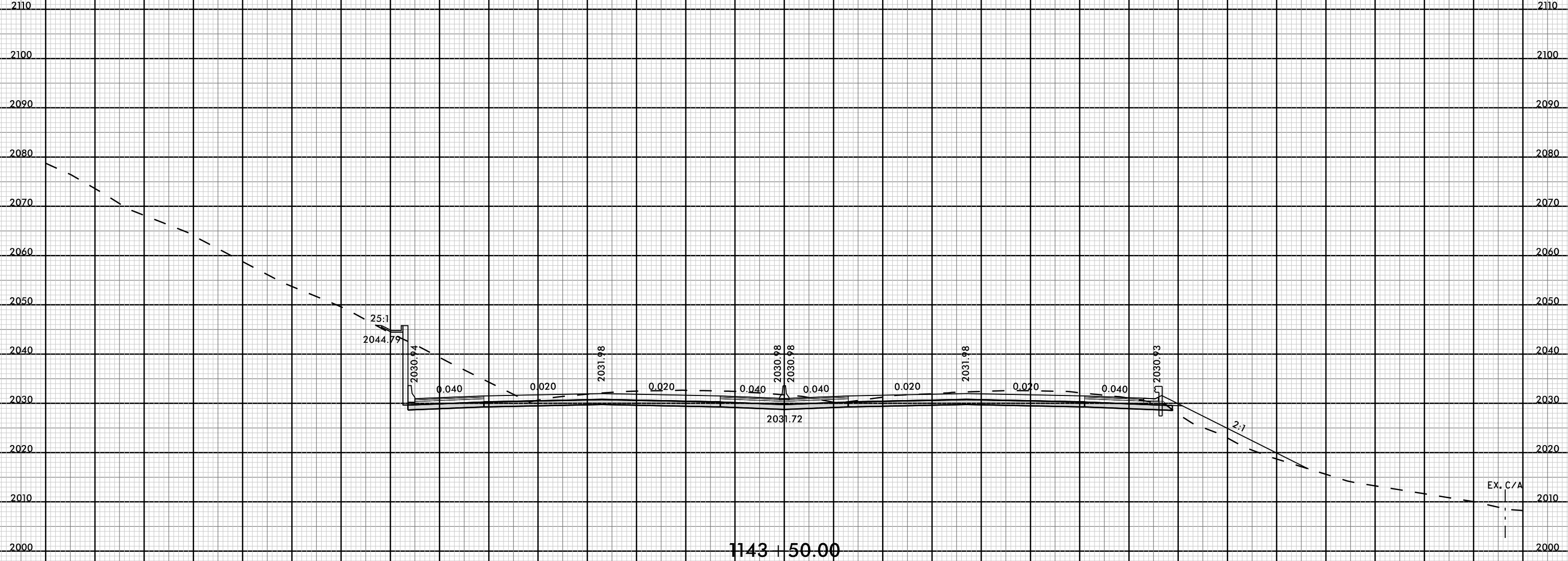

08-MAR-2009 11:54 AM
I:\4700\B-ROAD-XPL-L-3.dgn
FINITB

140 130 120 110 100 90 80 70 60 50 40 30 20 10 0 10 20 30 40 50 60 70 80 90 100 110 120 130 140 150

8/23/99



PROJ. REFERENCE NO.
I-4700

SHEET NO.
X-539

140 130 120 110 100 90 80 70 60 50 40 30 20 10 0 10 20 30 40 50 60 70 80 90 100 110 120 130 140 150

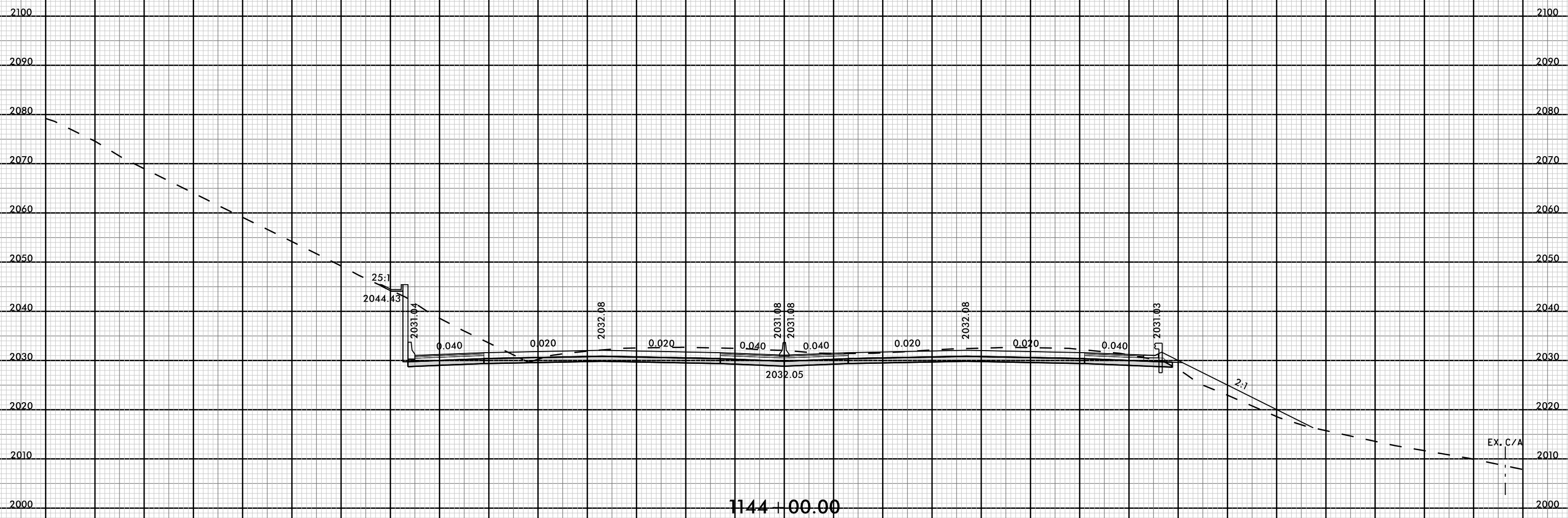

08-MAR-2019 11:54 AM
I:\147000\RDY_XPL.L3.dgn
FNITB



8/23/99

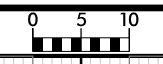

PROJ. REFERENCE NO.	SHEET NO.
I-4700	X-540

140 130 120 110 100 90 80 70 60 50 40 30 20 10 0 10 20 30 40 50 60 70 80 90 100 110 120 130 140 150

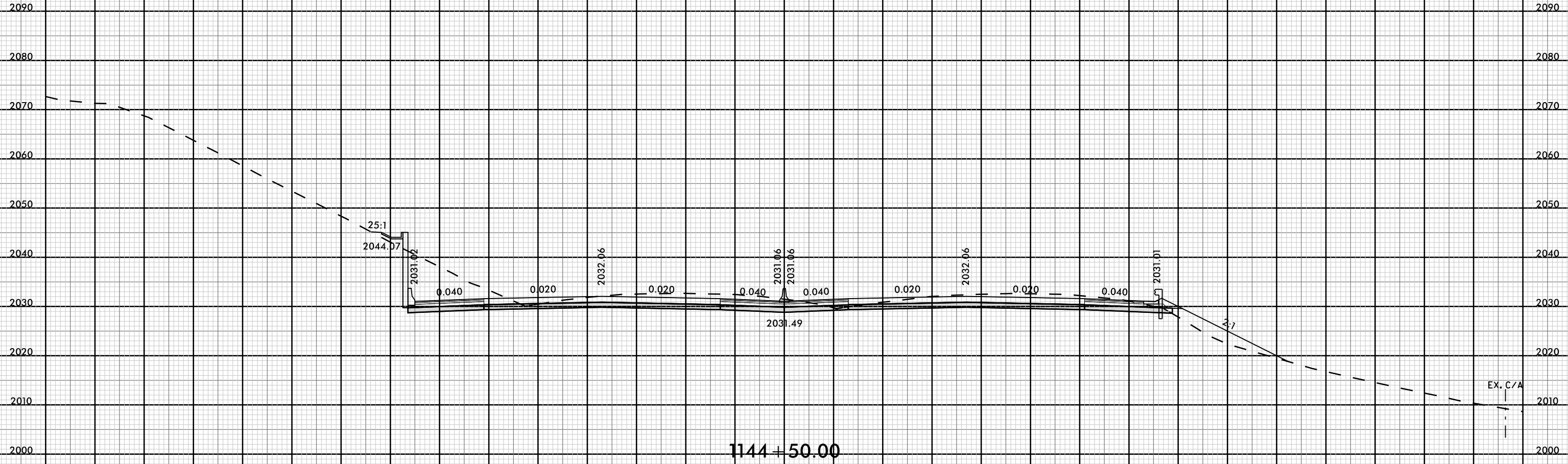

08-MAR-2009 11:54 AM
I:\4700\B-ROAD-XPL-L-3.dgn
FNITB

140 130 120 110 100 90 80 70 60 50 40 30 20 10 0 10 20 30 40 50 60 70 80 90 100 110 120 130 140 150

