

EDI MODEL 2018ECLip-NC CONFLICT MONITOR PROGRAMMING DETAIL

(remove jumpers and set switches as shown)

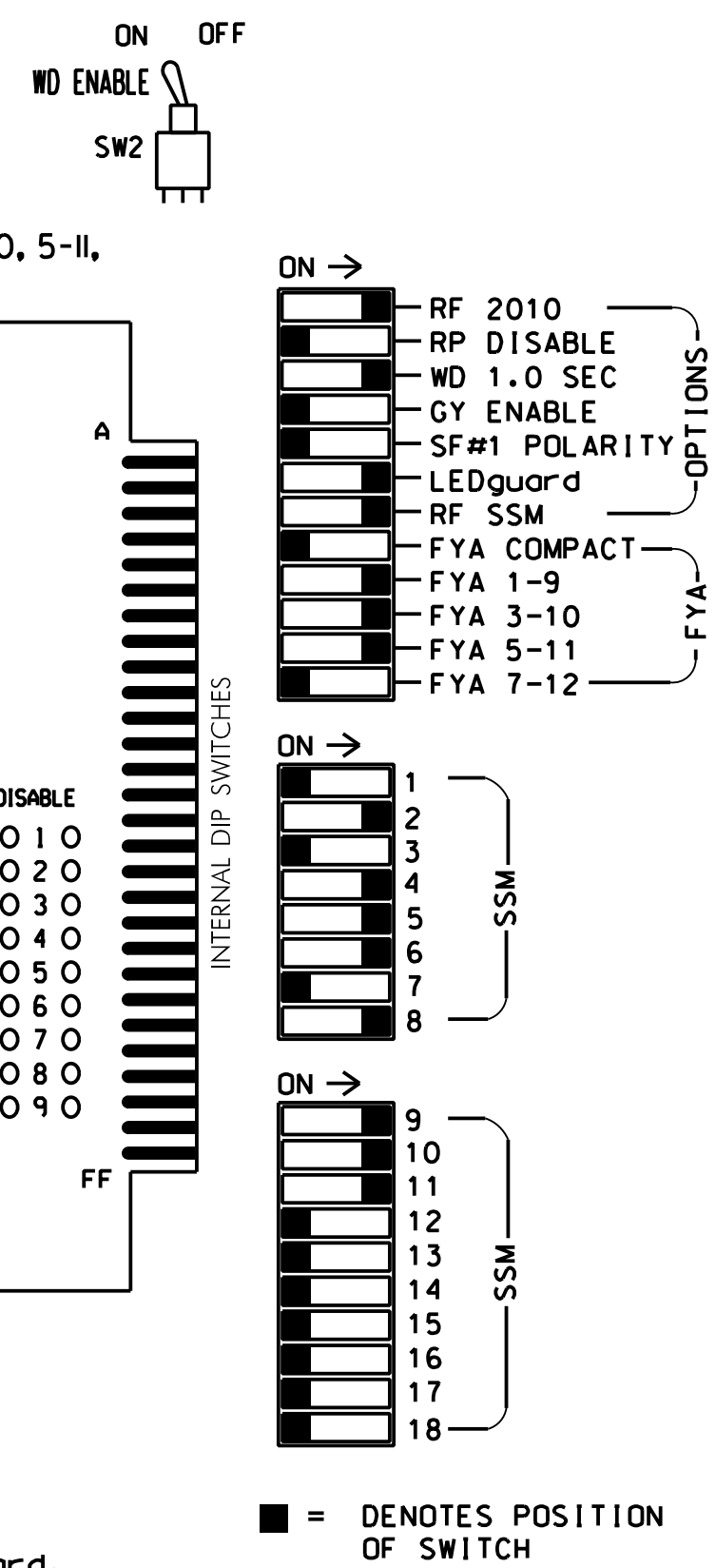
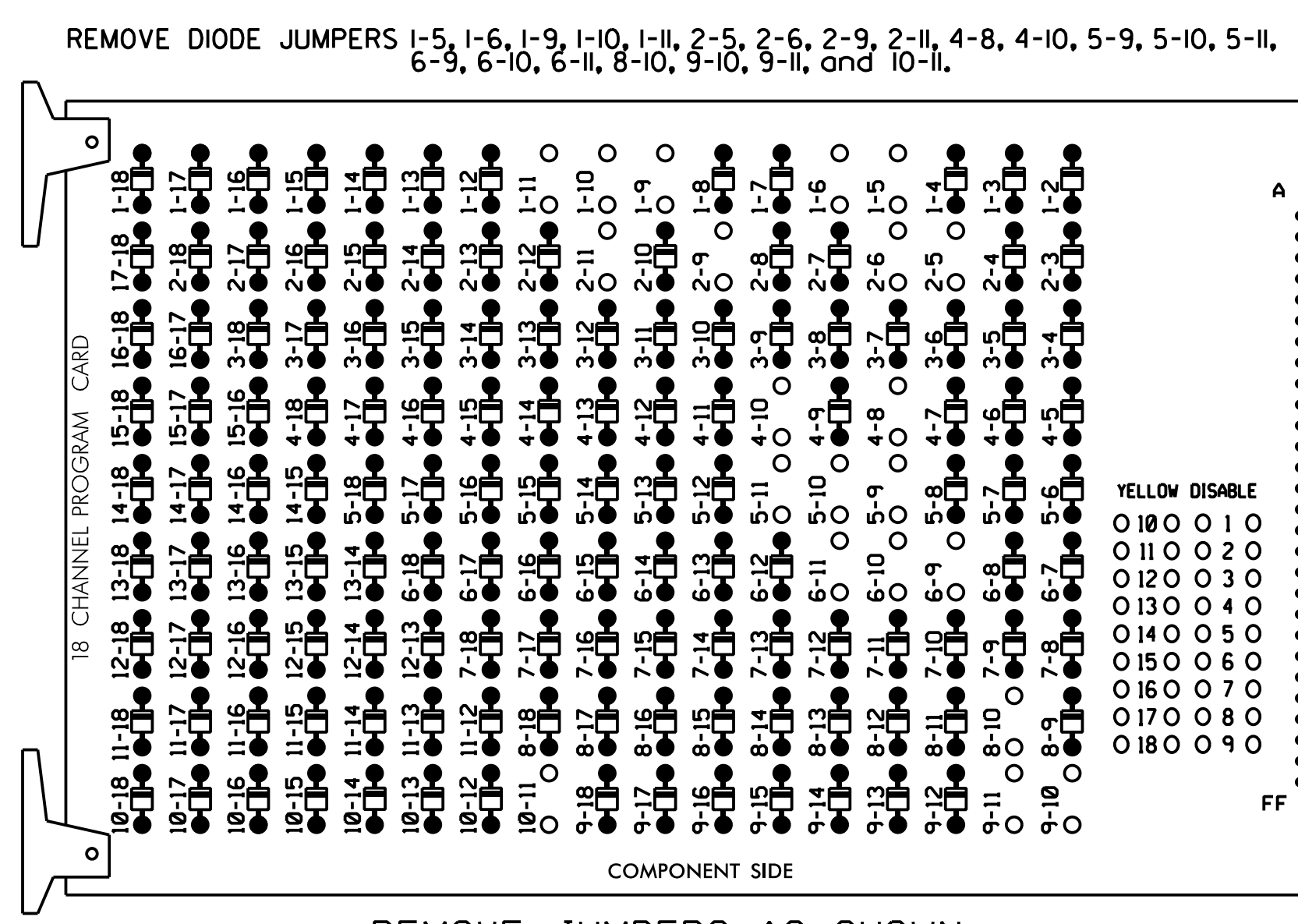

NOTES:

- Card is provided with all diode jumpers in place. Removal of any jumper allows its channels to run concurrently.
- Ensure jumpers SEL2-SEL5 and SEL9 are present on the monitor board.
- Ensure that Red Enable is active at all times during normal operation.
- Integrate monitor with Ethernet network in cabinet.

NOTES

- To prevent "flash-conflict" problems, insert red flash program blocks for all unused vehicle load switches in the output file. The installer shall verify that signal heads flash in accordance with the Signal Plans.
- Program phases 4 and 8 for Dual Entry.
- Enable Simultaneous Gap-Out for all Phases.
- Program phases 2 and 6 for Variable Initial and Gap Reduction.
- Program phases 2 and 6 for Startup In Green.
- Program phases 2 and 6 for Yellow Flash, and overlaps 1 and 2 as Wag Overlaps.
- The cabinet and controller are part of the Wilmington Signal System.

EQUIPMENT INFORMATION

CONTROLLER.....2070E
 CABINET.....332 W/ AUX
 SOFTWARE.....ECONOLITE OASIS
 CABINET MOUNT.....BASE
 OUTPUT FILE POSITIONS...18 WITH AUX. OUTPUT FILE
 LOAD SWITCHES USED.....S1,S2,S5,S7,S8,S11,AUX S1,
 AUX S2,AUX S4

PHASES USED.....1,2,4,5,6,8
 OVERLAP "A".....1+2
 OVERLAP "B".....1+8
 OVERLAP "C".....5+6
 OVERLAP "D".....NOT USED

SIGNAL HEAD HOOK-UP CHART

LOAD SWITCH NO.	S1	S2	S3	S4	S5	S6	S7	S8	S9	S10	S11	S12	AUX S1	AUX S2	AUX S3	AUX S4	AUX S5	AUX S6
CMU CHANNEL NO.	1	2	13	3	4	14	5	6	15	7	8	16	9	10	17	11	12	18
PHASE	1	2	PED	3	4	PED	5	6	PED	7	8	PED	OLA	OLB	SPARE	OLC	OLD	SPARE
SIGNAL HEAD NO.	11	21,22	NU	NU	41,42	NU	42	51	61,62	NU	NU	81,82	NU	11	83	NU	51	NU
RED		128			101		*		134			107			A124			
YELLOW	*	129			102				135			108						
GREEN		130			103				136			109						
RED ARROW															A121			A114
YELLOW ARROW								132							A122	A125		A115
FLASHING YELLOW ARROW															A123	A126		A116
GREEN ARROW	127						133	133										

NU = Not Used

* Denotes install load resistor. See load resistor installation detail this sheet.
 ★ See pictorial of head wiring in detail this sheet.

INPUT FILE POSITION LAYOUT

(front view)

FILE "I"	1	2	3	4	5	6	7	8	9	10	11	12	13	14
U	∅ 1	∅ 1	∅ 2	∅ 4	∅ 5	∅ 6	∅ 8	∅ 9	∅ 10	∅ 11	∅ 12	∅ 13	∅ 14	FS
L	ZONE 1A	ZONE 1B	ZONE 2A	ZONE 4A	ZONE 5A	ZONE 6A	ZONE 8A	ZONE 9A	ZONE 10A	ZONE 11A	ZONE 12A	ZONE 13A	ZONE 14A	DC ISOLATOR
U	NOT USED	NOT USED	∅ 2	NOT USED	∅ 5	∅ 6	NOT USED	∅ 9	∅ 10	∅ 11	∅ 12	∅ 13	∅ 14	DC ISOLATOR
L	ZONE 1B	ZONE 2B	∅ 2	NOT USED	∅ 5	∅ 6	NOT USED	∅ 9	∅ 10	∅ 11	∅ 12	∅ 13	∅ 14	DC ISOLATOR

EX.: 1A, 2A, ETC. = LOOP NO.'S
 FS = FLASH SENSE
 ST = STOP TIME
 ⊗ Wired Input - Do not populate slot with detector card

INPUT FILE CONNECTION & PROGRAMMING CHART

LOOP NO.	LOOP TERMINAL	INPUT FILE POS.	PIN NO.	INPUT ASSIGNMENT NO.	DETECTOR NO.	NEMA PHASE	CALL	EXTEND	FULL TIME DELAY	STRETCH TIME	DELAY TIME
ZONE 1A ¹	**	I1U	56	18	1	1	Y	Y			10
	-	J4U	48	10★	26	6	Y	Y	Y		3
	-	I1U	56	18★	51	1	Y	Y			3
ZONE 1B	**	I2U	39	1	2	1	Y	Y			15
ZONE 2A	**	I3U	63	25	32	2	Y	Y			
ZONE 2B	**	I3L	76	38	42	2	Y	Y			
ZONE 4A	**	I6U	41	3	4	4	Y	Y			
ZONE 5A ²	**	J1U	55	17	5	5	Y	Y			10
	-	I4U	47	9★	22	2	Y	Y	Y		3
	-	J1U	55	17★	55	5	Y	Y			3
ZONE 5B	**	J2U	40	2	6	5	Y	Y			15
ZONE 6A	**	J3U	64	26	36	6	Y	Y			
ZONE 6B	**	J3L	77	39	46	6	Y	Y			
ZONE 8A	**	J6U	42	4	8	8	Y	Y			

- Add jumper from I1-W to J4-W, on rear of input file.
 - Add jumper from J1-W to I4-W, on rear of input file.
- * See Input Page Assignment programming details on sheets 3 and 4.
 ** Multizone Microwave Detector Zone. See Special Detector Note.

INPUT FILE POSITION LEGEND: J2L

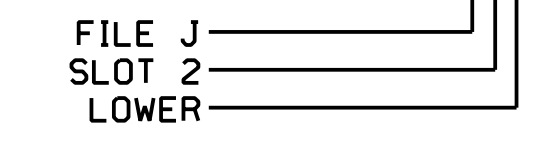

SPECIAL DETECTOR NOTE

Install a microwave detection system for vehicle detection. Perform installation according to manufacturer's directions and NCDOT engineer-approved mounting locations to accomplish the detection schemes shown on the Signal Design Plans.

See vehicle detector setup programming detail for alternate phasing on sheets 3, 4, and 5.

LOAD RESISTOR INSTALLATION DETAIL

(install resistors as shown)

ACCEPTABLE VALUES	VALUE (ohms)	WATTAGE
	1.5K - 1.9K	25W (min)
	2.0K - 3.0K	10W (min)

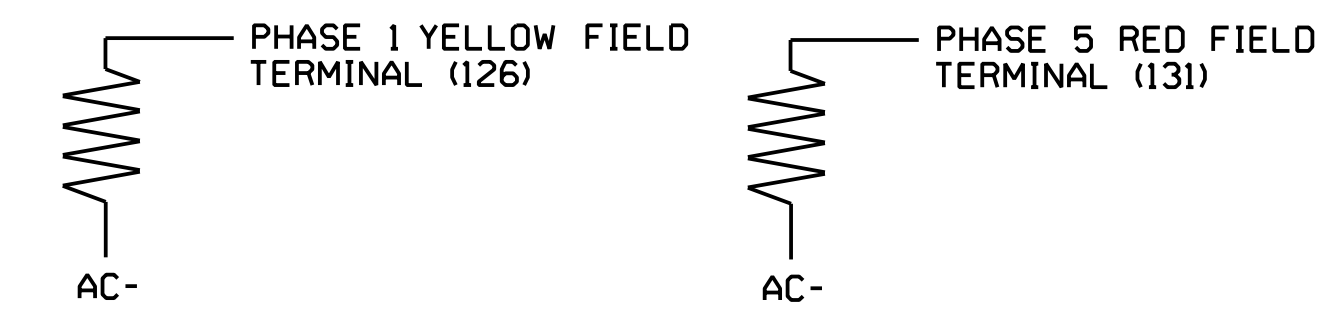

FYA SIGNAL WIRING DETAIL

(wire signal heads as shown)

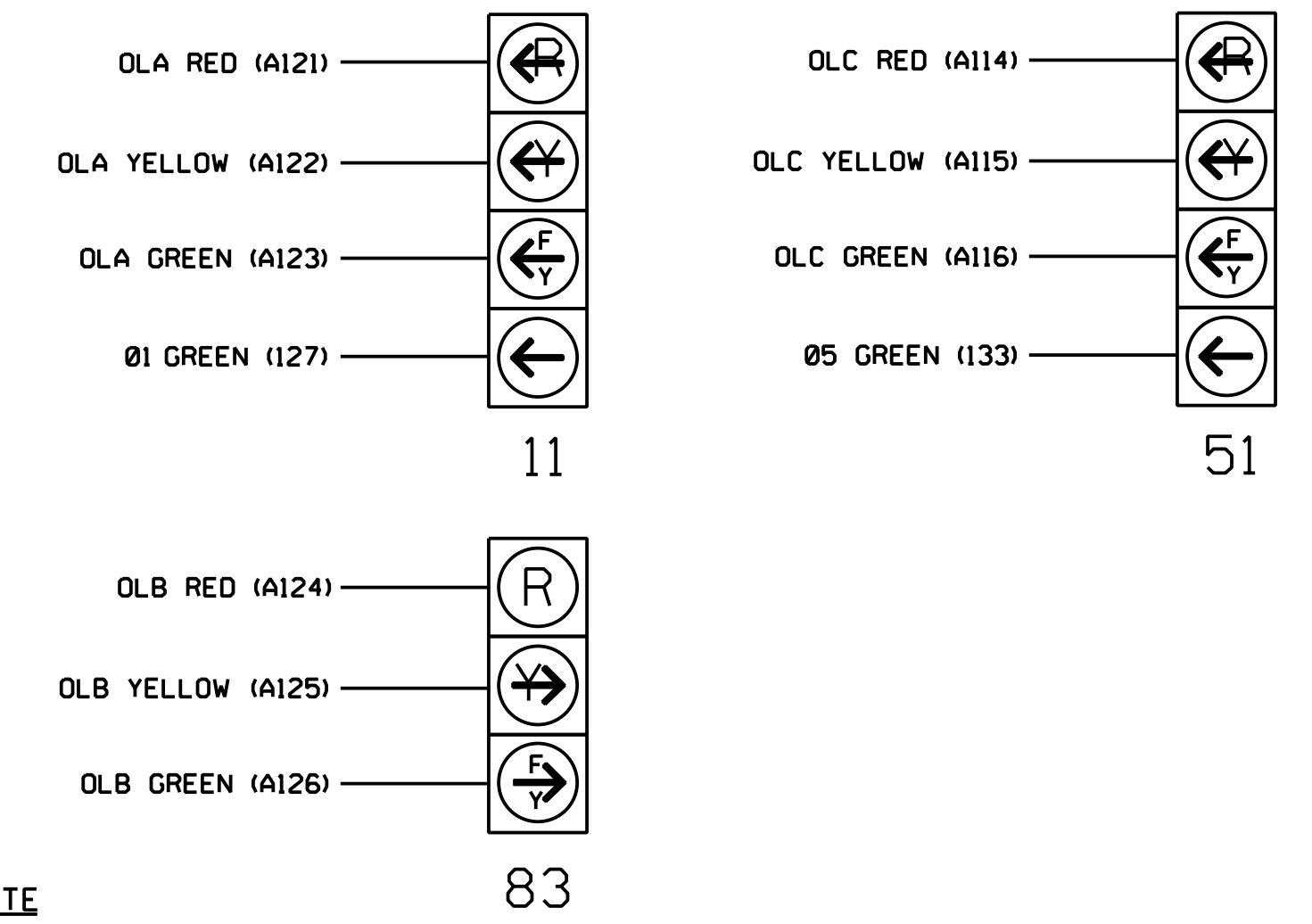

NOTE

The sequence display for signal heads 11 and 51 requires special logic programming. See sheet 2 for programming instructions.

THIS ELECTRICAL DETAIL IS FOR THE SIGNAL DESIGN: 03-1027T2
 DESIGNED: February 2018
 SEALED: 8-1-18
 REVISED: N/A

Electrical Detail - Sheet 1 of 5
 Signal Upgrade
 Temporary Design 2

DOCUMENT NOT CONSIDERED FINAL UNLESS ALL SIGNATURES COMPLETED

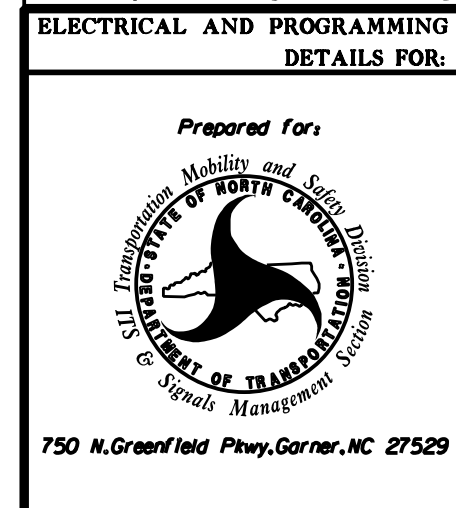

US 17 (Market Street) at SR 2734 (Marsh Oaks Drive) / SR 2290 (Mendenhall Drive)	
Division 03	New Hanover Co. Wilmington
PLAN DATE: February 2018	REVIEWED BY: A.D. Klinksiek
PREPARED BY: A.H. Thornburg	REVIEWED BY: N.R. Simmons
REVISIONS	INIT. DATE

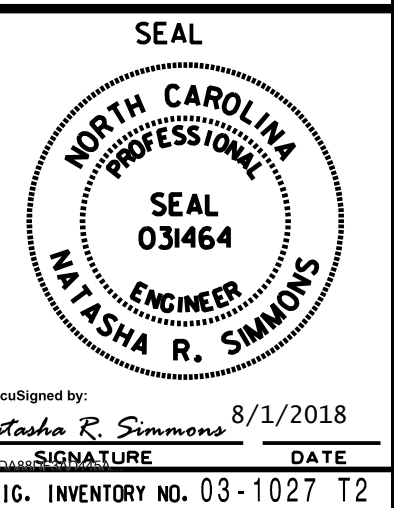

HNTB HNTB NORTH CAROLINA, P.C.
 343 E. Six Forks Road, Suite 200
 Raleigh, North Carolina 27609
 NC License No: C-1554
 (919) 546-8997