

**This electronic collection of documents is provided  
for the convenience of the user  
and is Not a Certified Document –**

**The documents contained herein were originally issued  
and sealed by the individuals whose names and license  
numbers appear on each page, on the dates appearing  
with their signature on that page.**

**This file or an individual page  
shall not be considered a certified document.**

**STATE OF NORTH CAROLINA  
DEPARTMENT OF TRANSPORTATION**

**PAVEMENT MARKING PLAN  
JOHNSTON COUNTY**

**LOCATION: NC 42 FROM SR 1902 (GLEN LAUREL RD) TO SR 1003 (BUFFALO RD)**

<small>TIP NO.</small> R-3825B	<small>SHEET NO.</small> PMP-1
<small>APPROVED:</small> <small>DATE:</small> 6/5/2018	
<b>DOCUMENT NOT CONSIDERED FINAL UNLESS ALL SIGNATURES COMPLETED</b>	

**T.I.P.: R-3825B**

**CONTRACT: C204108**

**ROADWAY STANDARD DRAWING**

THE FOLLOWING ROADWAY STANDARDS AS APPEAR IN "ROADWAY STANDARD DRAWINGS" - PROJECT SERVICES UNIT - N.C. DEPARTMENT OF TRANSPORTATION - RALEIGH, N.C., DATED JANUARY 2018 ARE APPLICABLE TO THIS PROJECT AND BY REFERENCE HEREBY ARE CONSIDERED A PART OF THESE PLANS:

STD. NO.	TITLE
1205.01	PAVEMENT MARKINGS - LINE TYPES AND OFFSETS
1205.02	PAVEMENT MARKINGS - TWO-LANE AND MULTILANE ROADWAYS
1205.04	PAVEMENT MARKINGS - INTERSECTIONS
1205.05	PAVEMENT MARKINGS - TURN LANES
1205.06	PAVEMENT MARKINGS - LANE DROPS
1205.07	PAVEMENT MARKINGS - PEDESTRIAN CROSSWALKS
1205.08	PAVEMENT MARKINGS - SYMBOLS AND WORD MESSAGES
1205.09	PAVEMENT MARKINGS - PAINTED ISLANDS
1205.10	PAVEMENT MARKINGS - SCHOOL AREAS
1205.12	PAVEMENT MARKINGS - BRIDGES
1205.13	PAVEMENT MARKINGS - LANE REDUCTIONS
1205.15	PAVEMENT MARKINGS - SUPERSTREETS
1250.01	RAISED PAVEMENT MARKERS - INSTALLATION SPACING
1251.01	RAISED PAVEMENT MARKERS - PERMANENT AND TEMPORARY
1251.01	RAISED PAVEMENT MARKERS - SNOWPLOWABLE
1261.01	GUARDRAIL AND BARRIER DELINEATORS - INSTALLATION SPACING
1261.02	GUARDRAIL AND BARRIER DELINEATORS - TYPES AND MOUNTING
1262.01	GUARDRAIL END DELINEATION
1264.01	OBJECT MARKERS - TYPES
1264.02	OBJECT MARKERS - INSTALLATION

**GENERAL NOTES**

THE FOLLOWING GENERAL NOTES APPLY AT ALL TIMES FOR THE DURATION OF THE CONSTRUCTION PROJECT, EXCEPT WHEN OTHERWISE NOTED IN THE PLAN, OR DIRECTED BY THE ENGINEER.

- A) INSTALL PAVEMENT MARKINGS AND PAVEMENT MARKERS ON THE FINAL SURFACE AS FOLLOWS:
- | ROAD NAME    | MARKING                                  | MARKER                  |
|--------------|--|-------------------------|
| -L- (NC 42)  | THERMOPLASTIC                            | SNOWPLOWABLE            |
| -Y- LINES    | THERMOPLASTIC                            | MATCH EXISTING          |
| BRIDGE DECKS | COLD APPLIED PLASTIC<br>(TYPE II OR III) | PERMANENT RAISED MARKER |
- B) TIE PROPOSED PAVEMENT MARKING LINES TO EXISTING PAVEMENT MARKING LINES.
- C) REMOVE/REPLACE ANY CONFLICTING/DAMAGED PAVEMENT MARKINGS AND MARKERS.
- D) PASSING ZONES WILL BE DETERMINED IN THE FIELD AND MUST BE APPROVED BY THE ENGINEER.
- E) STOP BAR LOCATION AT NON-SIGNALIZED INTERSECTIONS MAY BE ADJUSTED AS DIRECTED BY THE ENGINEER.
- F) REMOVE ALL RESIDUE AND SURFACE LAITANCE BY ACCEPTABLE METHODS ON CONCRETE BRIDGE DECKS PRIOR TO PLACING COLD APPLIED PLASTIC PAVEMENT MARKING MATERIAL.
- G) UNLESS OTHERWISE SPECIFIED, HEATED-IN-PLACE THERMOPLASTIC MAY BE USED IN LIEU OF EXTRUDED THERMOPLASTIC FOR STOP BARS, SYMBOLS, CHARACTERS AND DIAGONALS. IF HEATED-IN-PLACE IS USED, IT SHALL BE PAID FOR USING THE EXTRUDED THERMOPLASTIC PAY ITEM.
- H) UNLESS OTHERWISE SPECIFIED, HEATED-IN-PLACE THERMOPLASTIC MAY BE USED IN LIEU OF COLD APPLIED PLASTIC FOR STOP BARS, SYMBOLS, CHARACTERS AND DIAGONALS ON ASPHALT OR CONCRETE ROADWAYS. IF HEATED-IN-PLACE IS USED, IT SHALL BE PAID FOR USING THE COLD APPLIED PAY ITEM.
- I) TYPE III COLD APPLIED PLASTIC MAY BE USED IN LIEU OF TYPE II COLD APPLIED PLASTIC. IF TYPE III COLD APPLIED PLASTIC IS USED, IT SHALL BE PAID FOR USING THE TYPE II COLD APPLIED PLASTIC PAY ITEM.
- J) SEE ROADWAY PLANS FOR ALTERNATE CURB RAMP DESIGNS WHEN INDICATED ON PAVEMENT MARKING DETAIL SHEETS.

**INDEX**

SHEET NO.	DESCRIPTION
PMP-1	PAVEMENT MARKING PLAN TITLE, GENERAL NOTES AND ROADWAY STANDARDS LIST
PMP-1A	PAVEMENT MARKING SCHEDULE
PMP-2-21	PAVEMENT MARKING DETAIL

PLAN PREPARED BY: N.C.D.O.T. SIGNING AND DELINEATION UNIT

AYMAN ALQUDWAH, PE \_\_\_\_\_ SIGNING & DELINEATION REGIONAL ENGINEER

ERIC WARD \_\_\_\_\_ SIGNING & DELINEATION PROJECT DESIGN ENGINEER

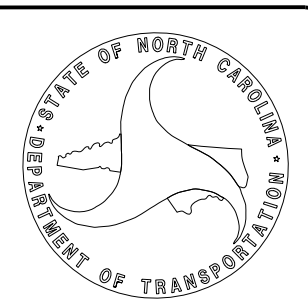

TIP NO. R-3825B	SHEET NO. SIGN-1A
APPROVED: <i>Ayman Alqudwah</i> F32AC5CAF985472	
DATE: 6/5/2018	
SEAL	
	
<b>DOCUMENT NOT CONSIDERED FINAL UNLESS ALL SIGNATURES COMPLETED</b>	

## R-3825B FINAL PAVEMENT MARKING SCHEDULE

SYMBOL	DESCRIPTION
	(FINAL PAVEMENT MARKINGS) THERMOPLASTIC (24", 120 MILS)
T2	WHITE STOPBAR THERMOPLASTIC (4", 90 MILS)
TA	WHITE EDGELINE
TB	YELLOW EDGELINE THERMOPLASTIC (4", 120 MILS)
T8	2 FT. - 6 FT./SP WHITE MINSKIP
T9	2 FT. - 6 FT./SP YELLOW MINSKIP
TC	10 FT. WHITE SKIP
TD	3 FT. - 9 FT./SP WHITE MINSKIP
TE	WHITE SOLD LANE LINE
TI	YELLOW DOUBLE CENTER THERMOPLASTIC (8", 90 MILS)
TP	YELLOW DIAGONAL THERMOPLASTIC (8", 120 MILS)
T13	3 FT. - 9 FT./SP WHITE MINSKIP
TQ	WHITE CROSSWALK LINE
TR	WHITE SOLD LANE LINE
	THERMOPLASTIC PAVEMENT MARKING SYMBOLS (90 MILS)
	UA - LEFT TURN ARROW
	UB - RIGHT TURN ARROW
	UC - STRAIGHT ARROW
	UD - COMBO LEFT/STRAIGHT ARROW
	UE - COMBO RIGHT/STRAIGHT ARROW
	UF - COMBO LEFT/RIGHT ARROW
	UG - COMBO LEFT/RIGHT/STRAIGHT ARROW
	UN - 24" YIELD LINE TRIANGLE
	UI - ALPHANUMERIC CHARACTER
	UP - MERGE ARROW
	UT - U-TURN ARROW
	(MARKERS) PERMANENT RAISED MARKERS
MA	YELLOW & YELLOW
MB	CRYSTAL & RED

SYMBOL	DESCRIPTION
	(FINAL PAVEMENT MARKINGS) THERMOPLASTIC (6", 90 MILS)
T6	WHITE EDGELINE
T7	YELLOW EDGELINE THERMOPLASTIC (6", 120 MILS)
T11	2 FT. - 6 FT./SP WHITE MINSKIP
T12	2 FT. - 6 FT./SP YELLOW MINSKIP
TJ	10 FT. WHITE SKIP
TK	3 FT. - 9 FT./SP WHITE MINSKIP
TL	WHITE SOLD LANE LINE
T16	YELLOW DOUBLE CENTER THERMOPLASTIC (12", 90 MILS)
TS	WHITE GORELINE
TU	WHITE DIAGONAL
TV	YELLOW DIAGONAL THERMOPLASTIC (12", 120 MILS)
TT	WHITE SOLD LANE LINE
T14	3 FT. - 9 FT./SP WHITE MINSKIP COLD APPLIED PLASTIC (6")
C6	WHITE EDGELINE
C7	YELLOW EDGELINE
CJ	10 FT. WHITE SKIP
CK	3 FT. - 9 FT./SP WHITE MINSKIP COLD APPLIED PLASTIC (12")
CS	WHITE GORELINE (MARKERS) SNOWPLOWABLE MARKERS
ME	YELLOW & YELLOW
MF	CRYSTAL & RED

06/05/18  
 P:\TIP\Projects-R\R3825B\Traffic\Signing\CADD\PM Plan\R-3825b\_pmp\_psh\_s01.dgn  
 User:rtward

**PAVEMENT MARKING SCHEDULE**



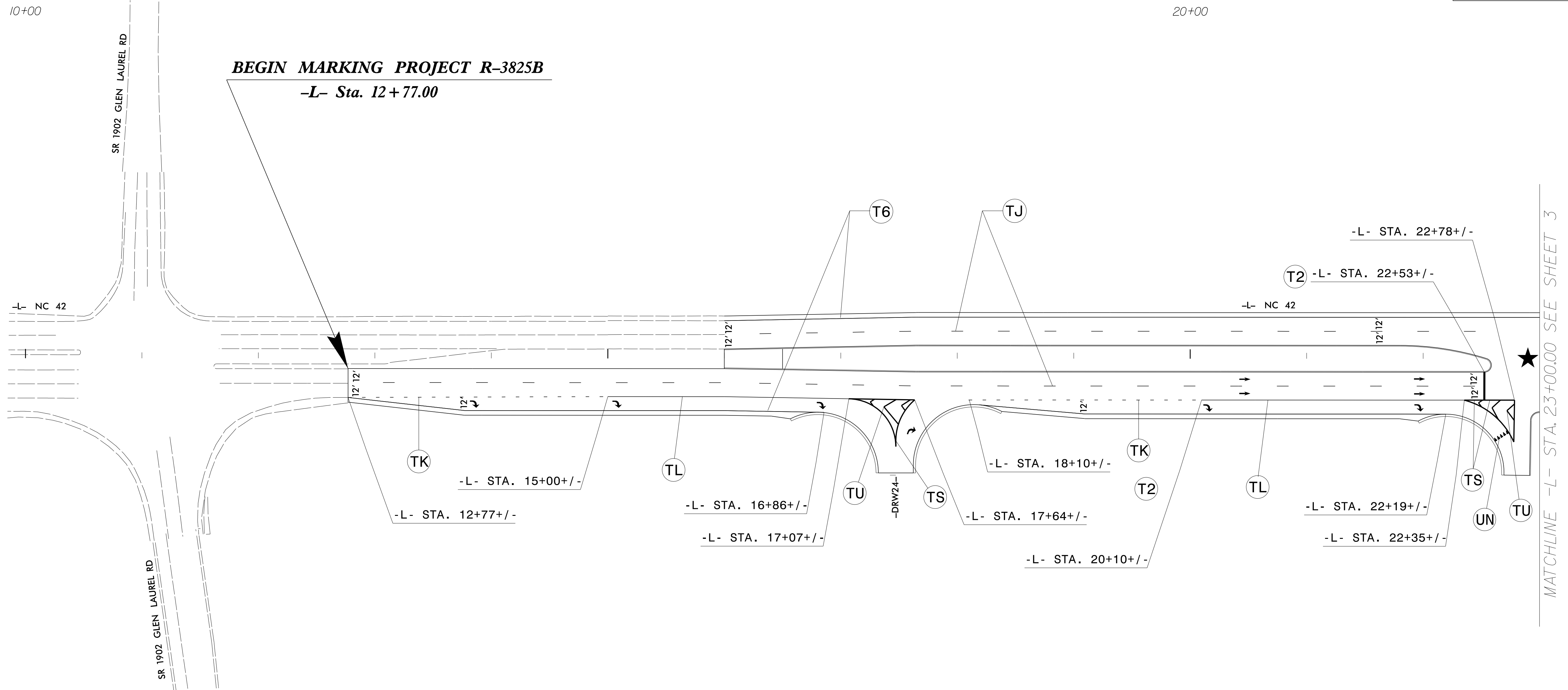

MATCHLINE -L- STA. 23+00.00 SEE SHEET 3

SYMBOL LEGEND	
	UA LEFT ARROW
	UB RIGHT ARROW
	UC STRAIGHT ARROW
	UD COMBO. LEFT/STRAIGHT ARROW
	UE COMBO. RIGHT/STRAIGHT ARROW
	UF COMBO. LEFT/RIGHT ARROW
	UG COMBO. LEFT/RIGHT/STRAIGHT ARROW
	ONLY SCHOOL UI ALPHANUMERIC CHARACTER
	UN 24" YIELD LINE TRIANGLE
	UP MERGE ARROW
	UT U-TURN ARROW

**PAVEMENT MARKING DETAIL**

06/04/18  
P:\TIP\Projects-R\R3825B\Traffic\Signing\CADD\PM Plan\R-3825b\_pmp\_psh\_s02.dgn  
User:rteward

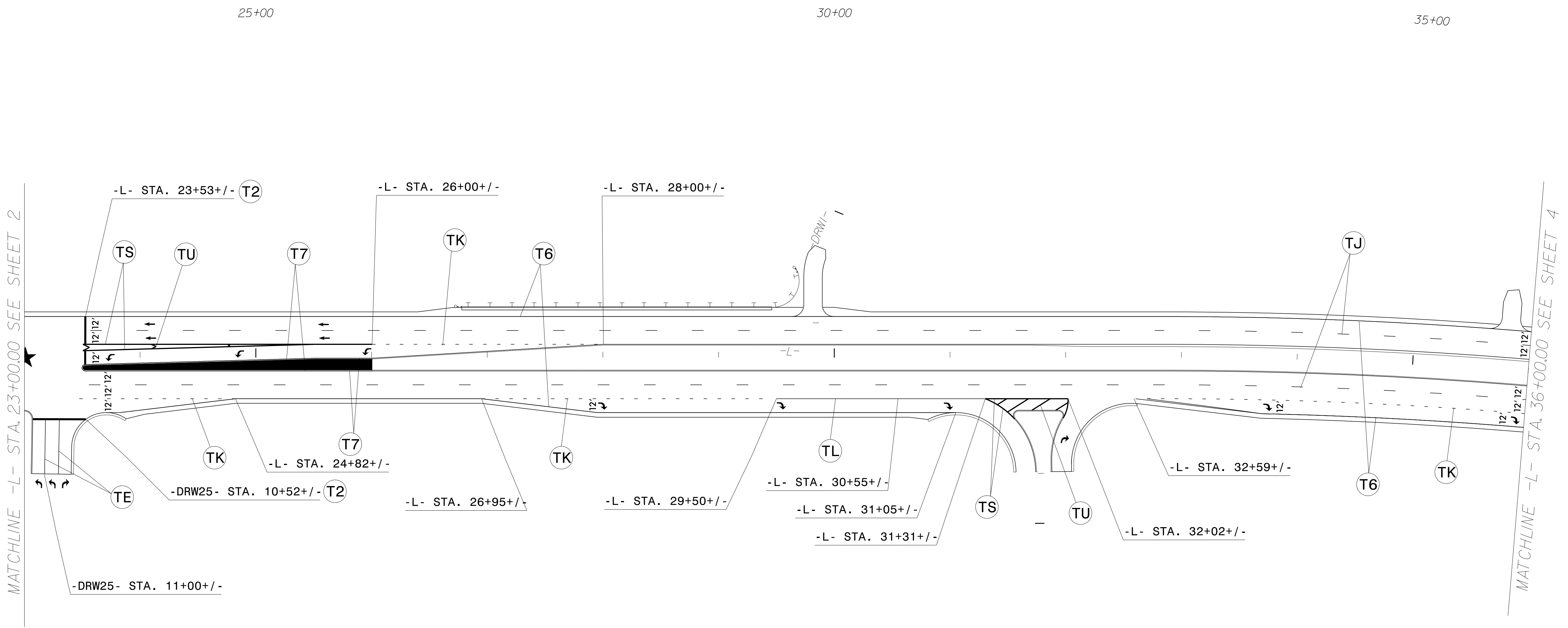
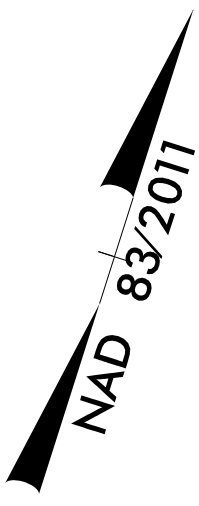

SYMBOL LEGEND			
UA	LEFT ARROW	UG	COMBO. LEFT/RIGHT/ STRAIGHT ARROW
UB	RIGHT ARROW	UI	ALPHANUMERIC CHARACTER
UC	STRAIGHT ARROW	UN	24" YIELD LINE TRIANGLE
UD	COMBO. LEFT/ STRAIGHT ARROW	UP	MERGE ARROW
UE	COMBO. RIGHT/ STRAIGHT ARROW	UT	U-TURN ARROW
UF	COMBO. LEFT/ RIGHT ARROW		

**PAVEMENT MARKING DETAIL**

06/04/18  
 P:\TIP\Projects-R\R3825B\Traffic\Signing\CADD\PM Plan\R-3825b\_pmp\_psh\_s03.dgn  
 User:rtward



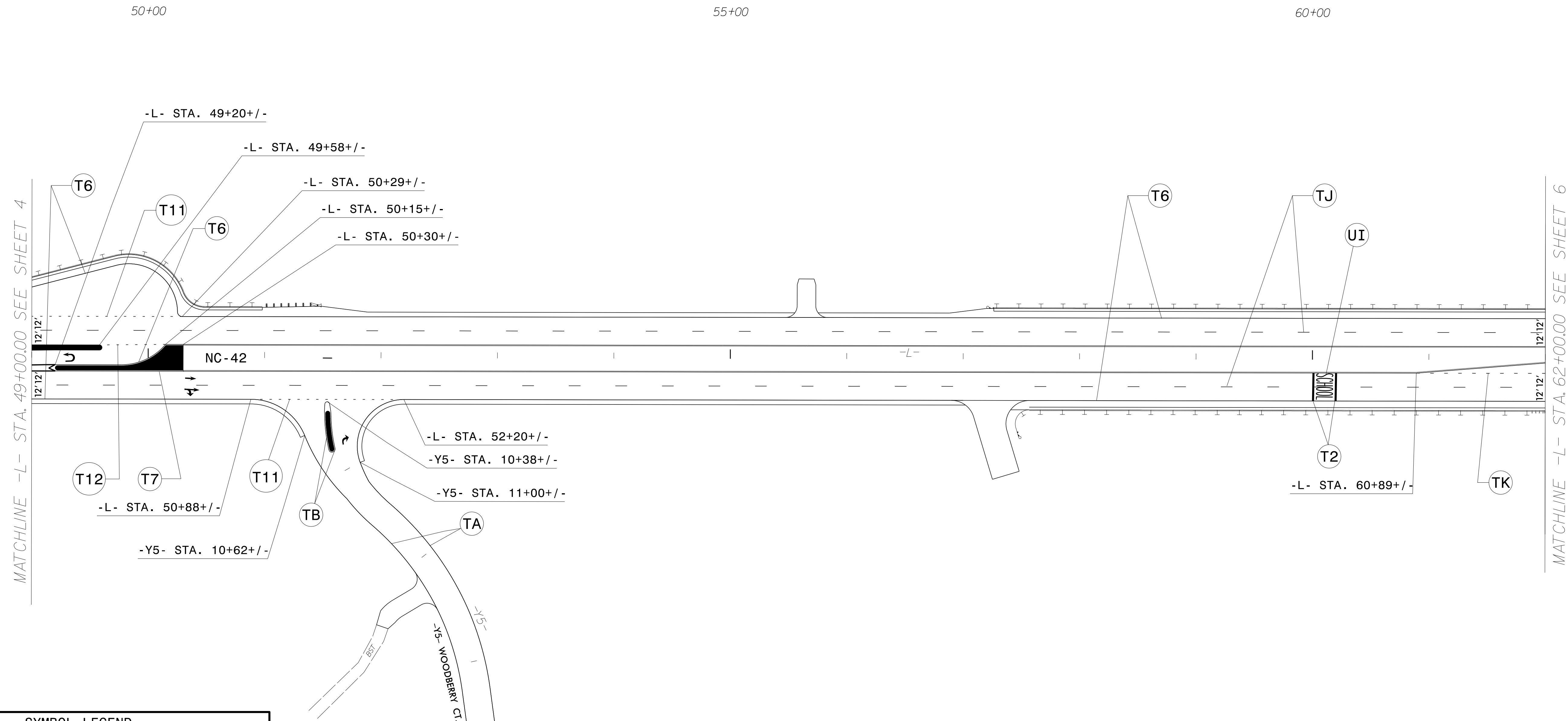

MATCHLINE -L- STA. 49+00.00 SEE SHEET 4

MATCHLINE -L- STA. 62+00.00 SEE SHEET 6

SYMBOL LEGEND					
	UA	LEFT ARROW		UG	COMBO. LEFT/RIGHT/ STRAIGHT ARROW
	UB	RIGHT ARROW		UI	ALPHANUMREIC CHARACTER
	UC	STRAIGHT ARROW		UN	24" YIELD LINE TRIANGLE
	UD	COMBO. LEFT/ STRAIGHT ARROW		UP	MERGE ARROW
	UE	COMBO. RIGHT/ STRAIGHT ARROW		UT	U-TURN ARROW
	UF	COMBO. LEFT/ RIGHT ARROW			

END CONSTRUCTION  
-Y5- POT Sta. 14+22.00

**PAVEMENT MARKING DETAIL**

06/04/18  
P:\TIP\Projects-R\R3825B\Traffic\Signing\CADD\PM Plan\R-3825b\_pmp\_psh\_s05.dgn  
User:rtward



SYMBOL LEGEND					
	UA	LEFT ARROW		UG	COMBO. LEFT/RIGHT/ STRAIGHT ARROW
	UB	RIGHT ARROW		UI	ALPHANUMERIC CHARACTER
	UC	STRAIGHT ARROW		UN	24" YIELD LINE TRIANGLE
	UD	COMBO. LEFT/ STRAIGHT ARROW		UP	MERGE ARROW
	UE	COMBO. RIGHT/ STRAIGHT ARROW		UT	U-TURN ARROW
	UF	COMBO. LEFT/ RIGHT ARROW			

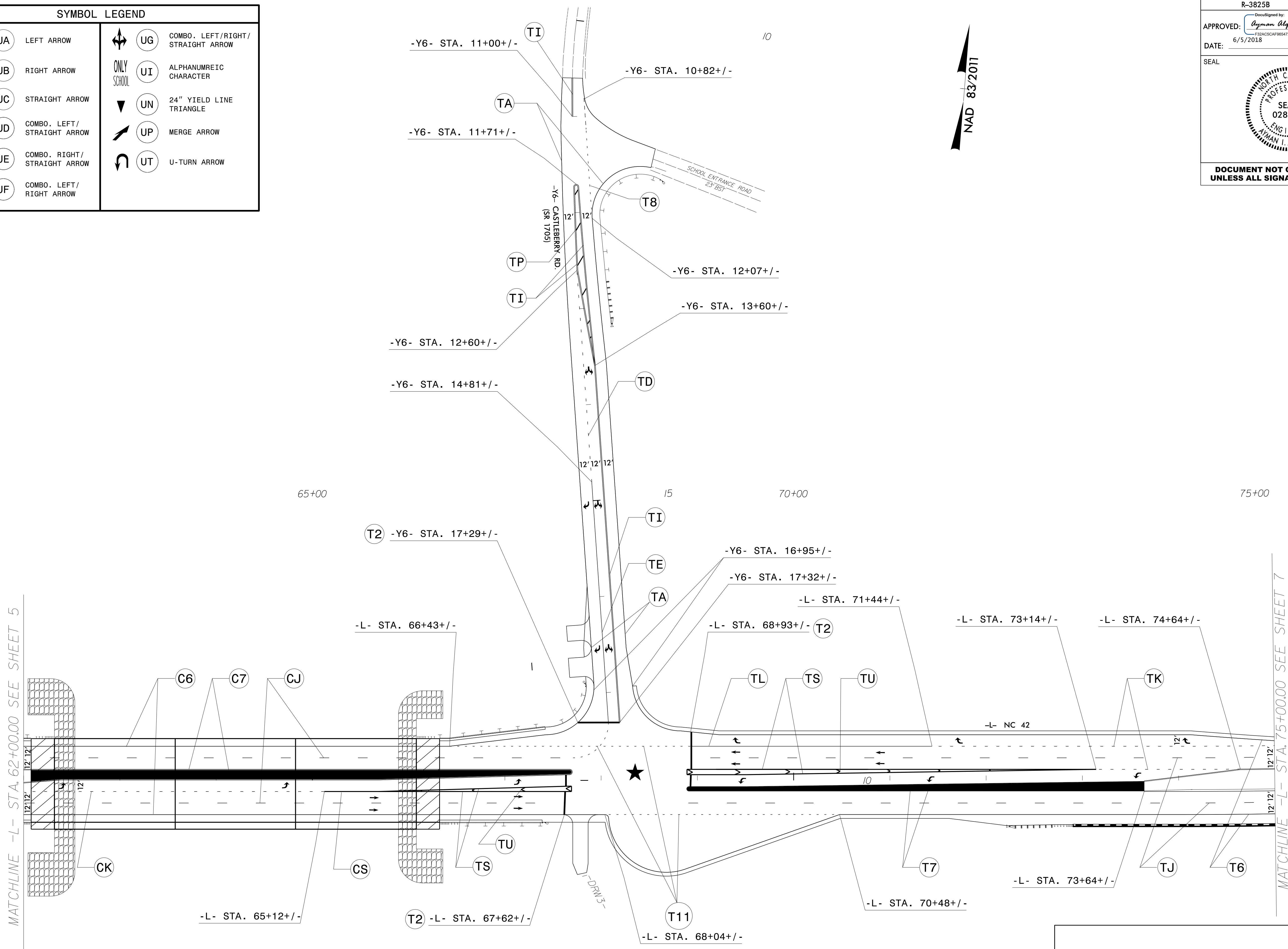

06/04/18  
 P:\TIP\Projects-R\3825B\Traffic\Signing\CADD\PMI Plan\3825b\_pmp\_psh\_s06.dgn  
 User:rtward

**PAVEMENT MARKING DETAIL**



SYMBOL LEGEND					
	UA	LEFT ARROW		UG	COMBO. LEFT/RIGHT/ STRAIGHT ARROW
	UB	RIGHT ARROW		UI	ALPHANUMERIC CHARACTER
	UC	STRAIGHT ARROW		UN	24" YIELD LINE TRIANGLE
	UD	COMBO. LEFT/ STRAIGHT ARROW		UP	MERGE ARROW
	UE	COMBO. RIGHT/ STRAIGHT ARROW		UT	U-TURN ARROW
	UF	COMBO. LEFT/ RIGHT ARROW			

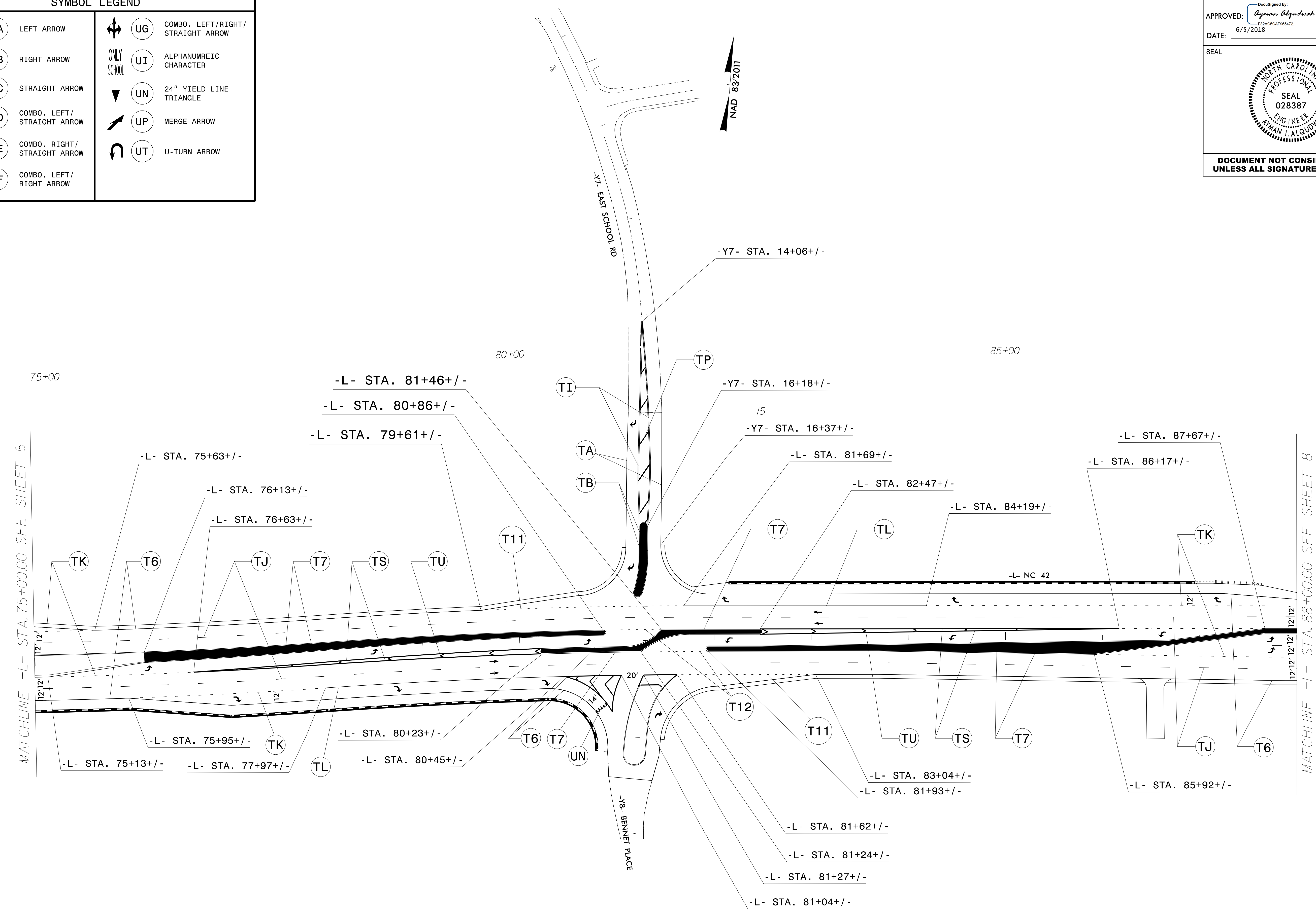

06/04/18  
 P:\TIP\Projects-R\R3825B\Traffic\Signing\CADD\PM Plan\R-3825b\_pmp\_psh\_s07.dgn  
 User:rtward

**PAVEMENT MARKING DETAIL**



APPROVED: *Osman Alqudwah*  
DocuSigned by:  
 Osman Alqudwah  
 F32AC5CAF985472...  
 DATE: 6/5/2018

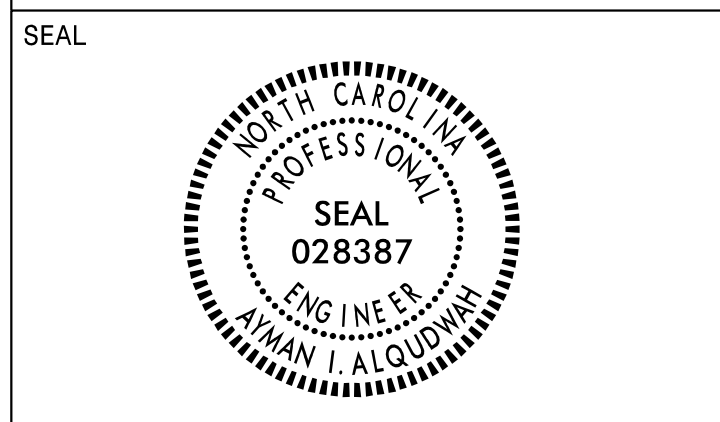

**DOCUMENT NOT CONSIDERED FINAL  
 UNLESS ALL SIGNATURES COMPLETED**

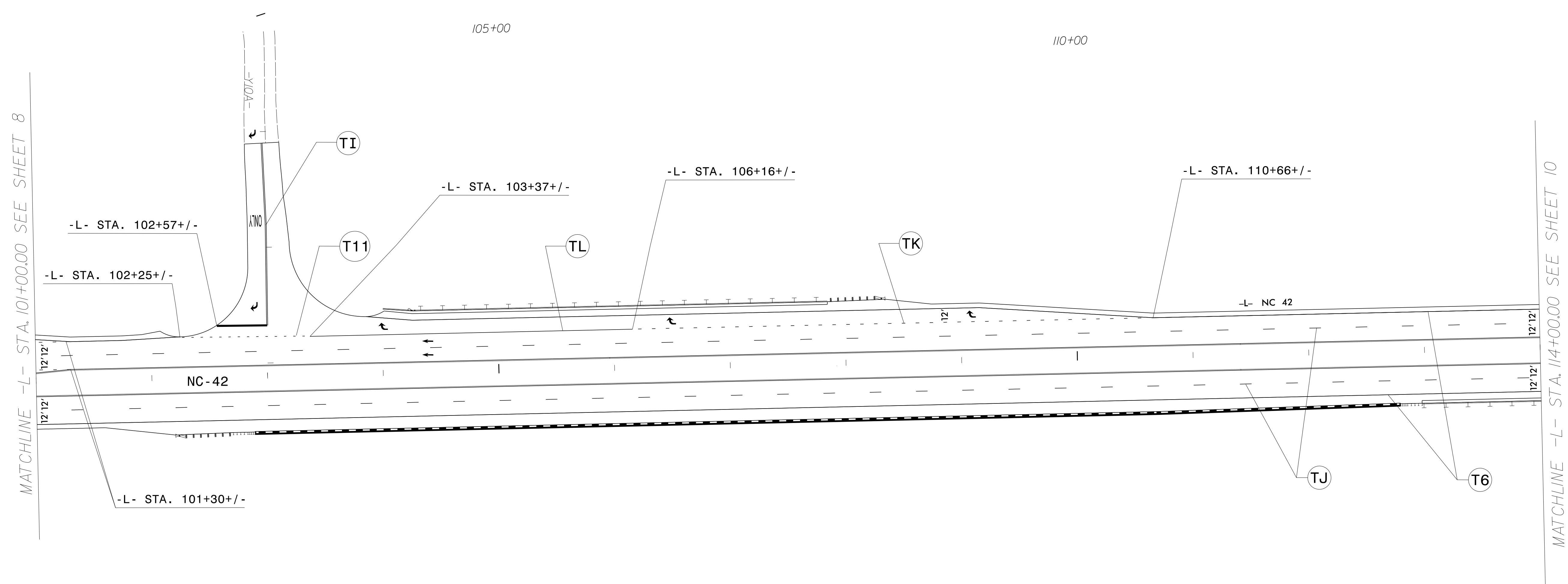
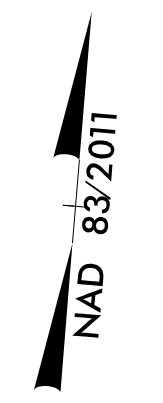

SYMBOL LEGEND	
	UA LEFT ARROW
	UB RIGHT ARROW
	UC STRAIGHT ARROW
	UD COMBO. LEFT/STRAIGHT ARROW
	UE COMBO. RIGHT/STRAIGHT ARROW
	UF COMBO. LEFT/RIGHT ARROW
	UG COMBO. LEFT/RIGHT/STRAIGHT ARROW
	ONLY SCHOOL UI ALPHANUMREIC CHARACTER
	UN 24" YIELD LINE TRIANGLE
	UP MERGE ARROW
	UT U-TURN ARROW

**PAVEMENT MARKING DETAIL**

06/04/18  
 P:\TIP\Projects-R\3825B\Traffic\Signing\CADD\PM Plan\3825b\_pmp\_psh\_s09.dgn  
 User:rtward





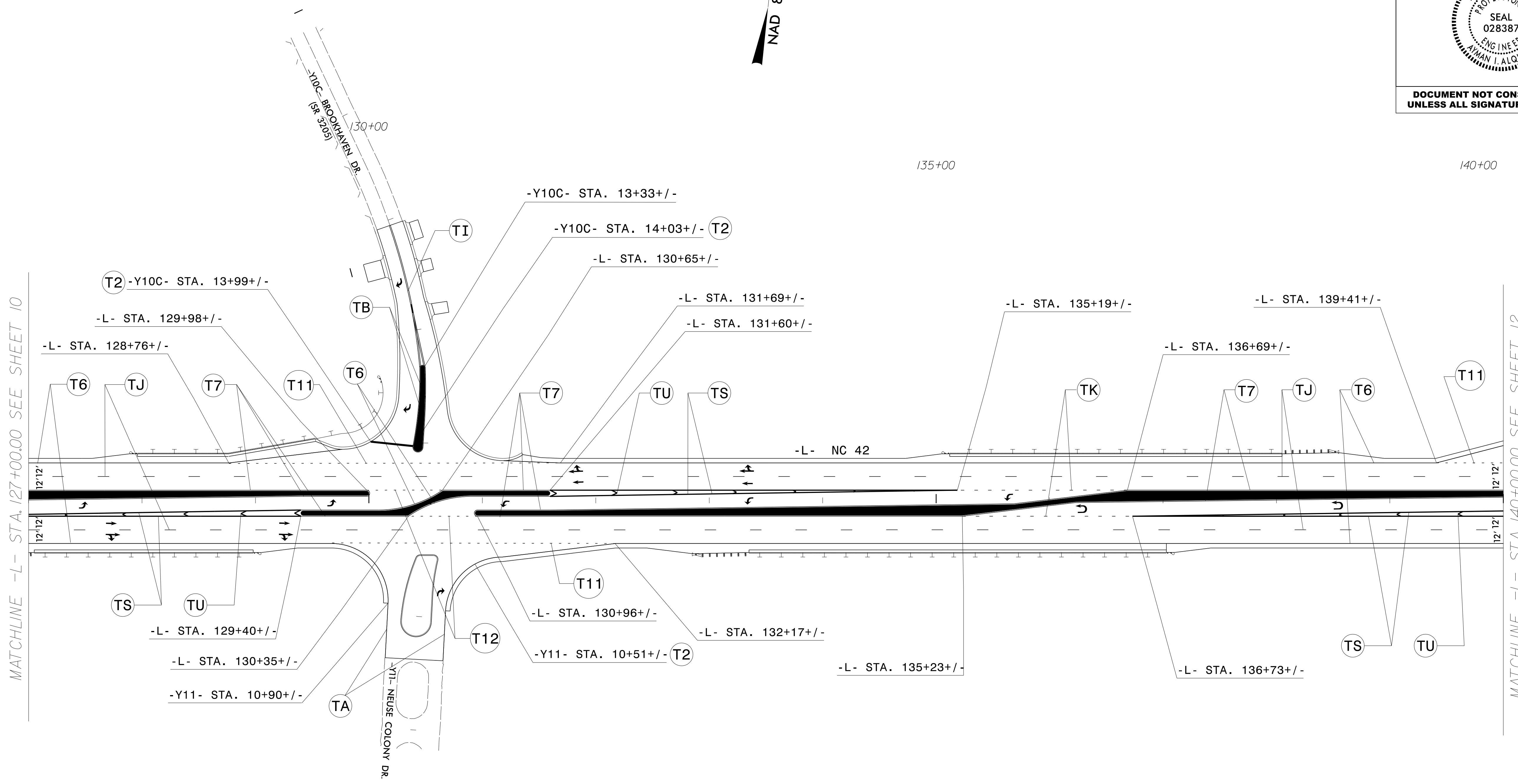
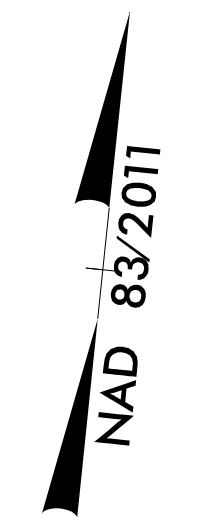

MATCHLINE -L- STA. 127+00.00 SEE SHEET 10

MATCHLINE -L- STA. 140+00.00 SEE SHEET 12

SYMBOL LEGEND					
	UA	LEFT ARROW		UG	COMBO. LEFT/RIGHT/ STRAIGHT ARROW
	UB	RIGHT ARROW		UI	ALPHANUMERIC CHARACTER
	UC	STRAIGHT ARROW		UN	24" YIELD LINE TRIANGLE
	UD	COMBO. LEFT/ STRAIGHT ARROW		UP	MERGE ARROW
	UE	COMBO. RIGHT/ STRAIGHT ARROW		UT	U-TURN ARROW
	UF	COMBO. LEFT/ RIGHT ARROW			

**PAVEMENT MARKING DETAIL**

06/04/18  
P:\TIP\Projects-R\R3825B\Traffic\Signing\CADD\PM Plan\R-3825b\_pmp\_psh\_s11.dgn  
User:rtward

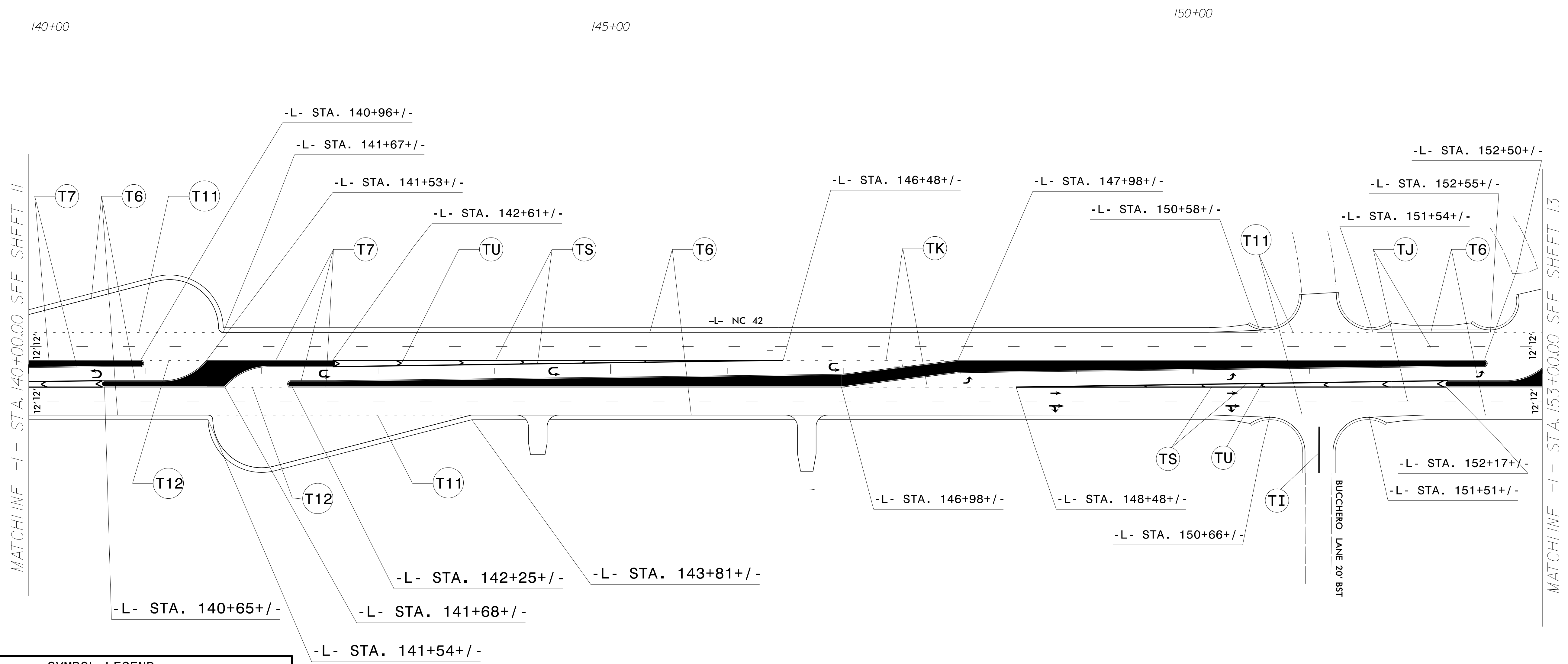
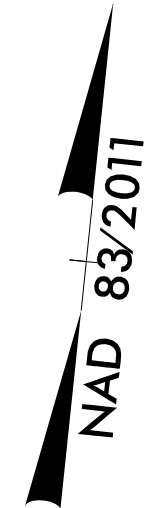

SYMBOL LEGEND					
	UA	LEFT ARROW		UG	COMBO. LEFT/RIGHT/ STRAIGHT ARROW
	UB	RIGHT ARROW		UI	ALPHANUMERIC CHARACTER
	UC	STRAIGHT ARROW		UN	24" YIELD LINE TRIANGLE
	UD	COMBO. LEFT/ STRAIGHT ARROW		UP	MERGE ARROW
	UE	COMBO. RIGHT/ STRAIGHT ARROW		UT	U-TURN ARROW
	UF	COMBO. LEFT/ RIGHT ARROW			

**PAVEMENT MARKING DETAIL**

06/04/18  
 P:\TIP\Projects-R\R3825B\Traffic\Signing\CADD\PM Plan\R-3825b\_pmp\_psh\_sl2.dgn  
 User:rtward



TIP NO. R-3825B	SHEET NO. PMP-13
APPROVED: <i>Uyman Alquodwah</i> <small>F32ACSCAP985472...</small> DATE: 6/5/2018	
SEAL 	
<b>DOCUMENT NOT CONSIDERED FINAL UNLESS ALL SIGNATURES COMPLETED</b>	

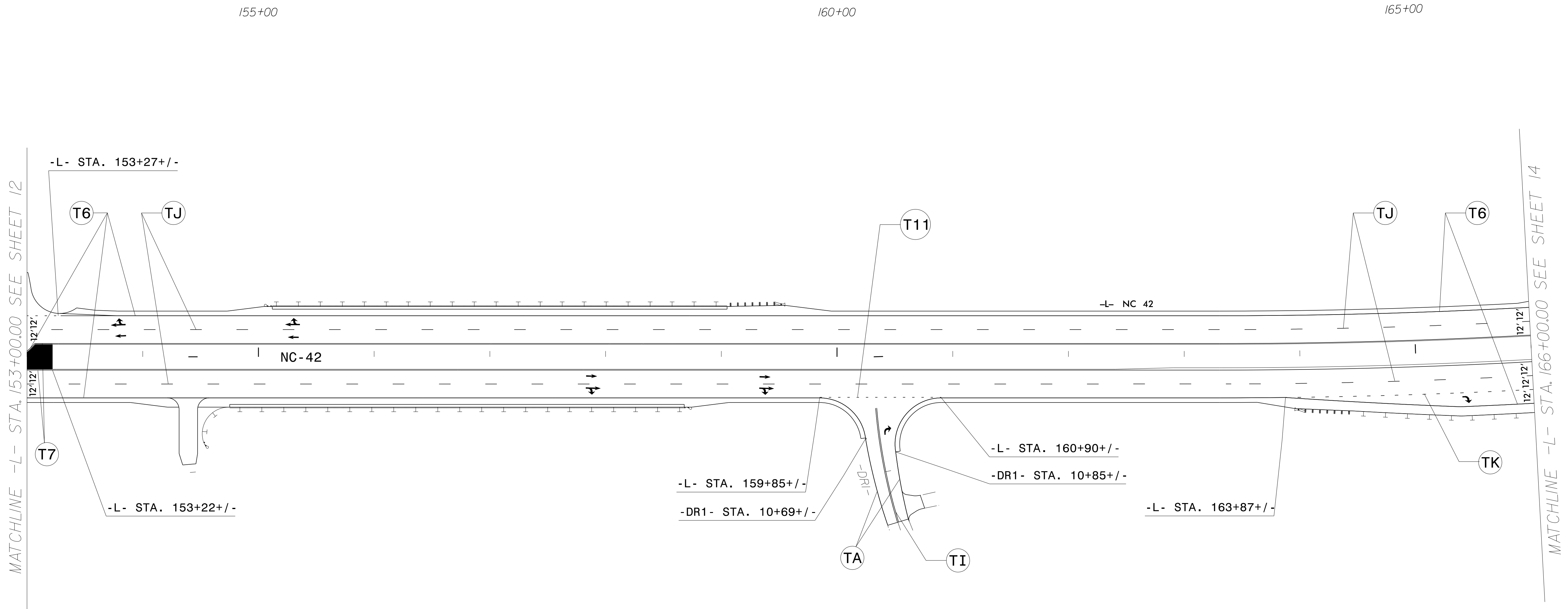

SYMBOL LEGEND	
	UA LEFT ARROW
	UB RIGHT ARROW
	UC STRAIGHT ARROW
	UD COMBO. LEFT/STRAIGHT ARROW
	UE COMBO. RIGHT/STRAIGHT ARROW
	UF COMBO. LEFT/RIGHT ARROW
	UG COMBO. LEFT/RIGHT/STRAIGHT ARROW
	ONLY SCHOOL UI ALPHANUMERIC CHARACTER
	UN 24" YIELD LINE TRIANGLE
	UP MERGE ARROW
	UT U-TURN ARROW

**PAVEMENT MARKING DETAIL**

06/04/18  
 P:\TIP\Projects-R\R3825B\Traffic\Signing\CADD\PM Plan\R-3825b\_pmp\_psh\_s13.dgn  
 User:rtward

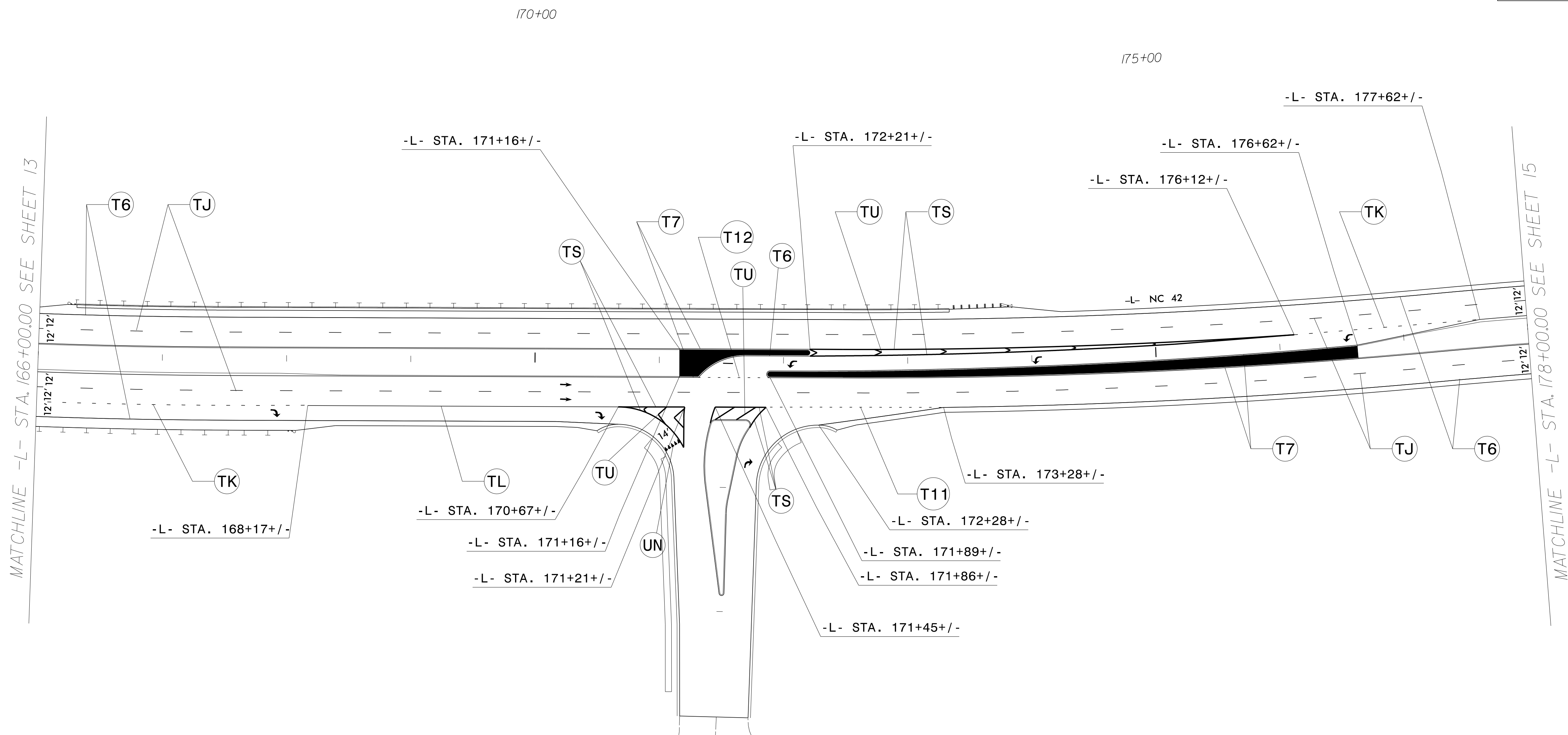
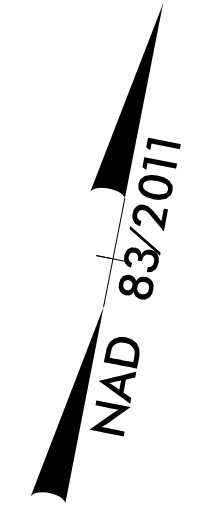

SYMBOL LEGEND	
	UA LEFT ARROW
	UB RIGHT ARROW
	UC STRAIGHT ARROW
	UD COMBO. LEFT / STRAIGHT ARROW
	UE COMBO. RIGHT / STRAIGHT ARROW
	UF COMBO. LEFT / RIGHT ARROW
	UG COMBO. LEFT / RIGHT / STRAIGHT ARROW
	ONLY SCHOOL UI ALPHANUMERIC CHARACTER
	UN 24" YIELD LINE TRIANGLE
	UP MERGE ARROW
	UT U-TURN ARROW

06/04/18  
 P:\TIP\Projects-R\3825B\Traffic\Signing\CADD\PM Plan\3825b\_pmp\_psh\_s14.dgn  
 User:rtward

**PAVEMENT MARKING DETAIL**

APPROVED: *Uyman Alquodwah*  
F32ACSCAP985472  
 DATE: 6/5/2018

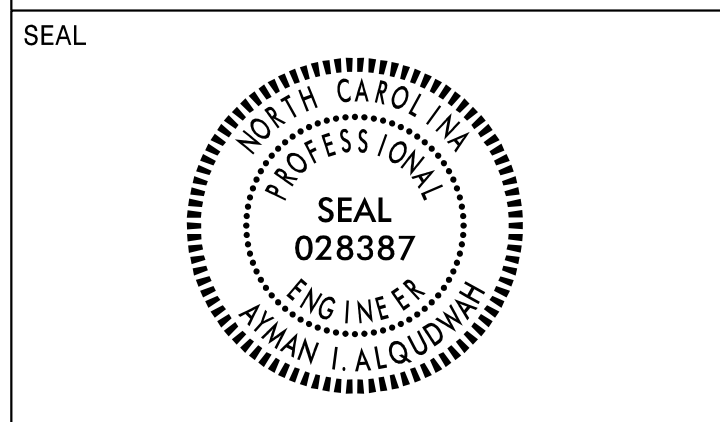

**DOCUMENT NOT CONSIDERED FINAL  
 UNLESS ALL SIGNATURES COMPLETED**

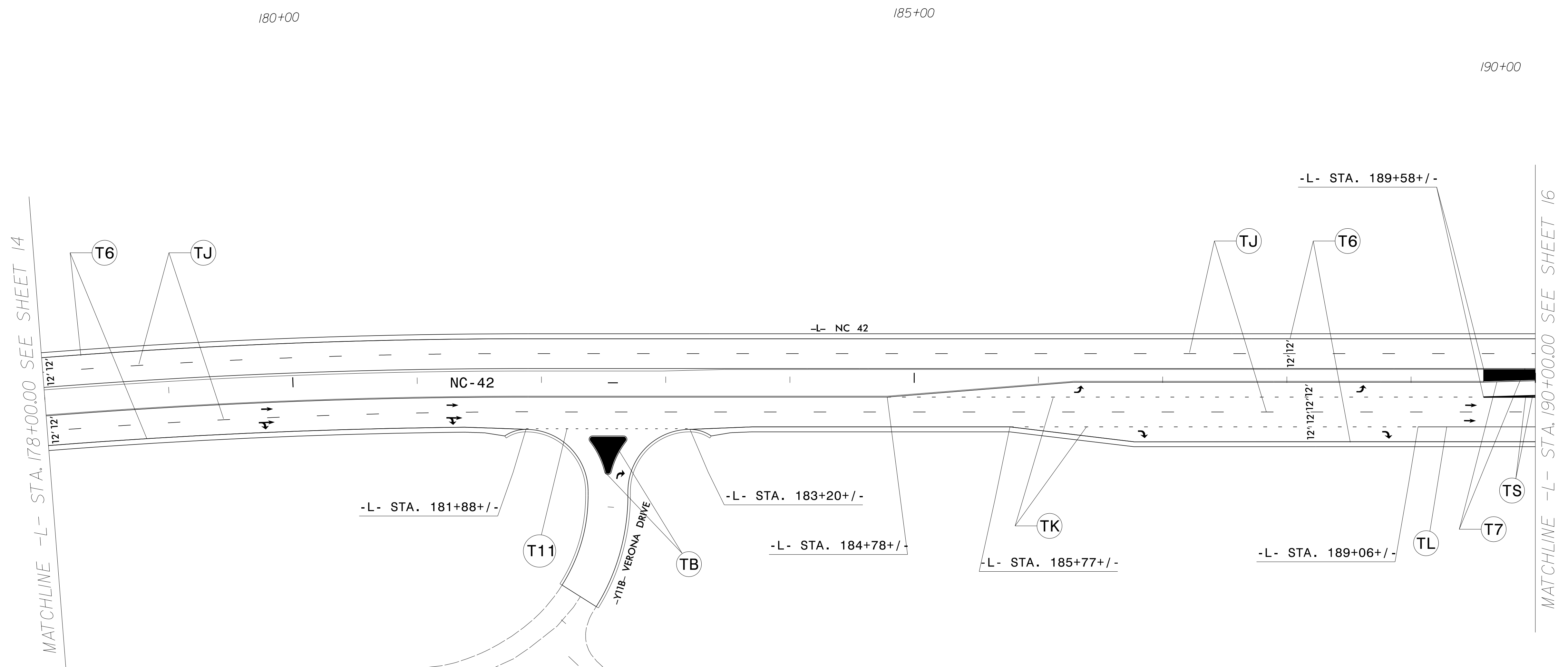

SYMBOL LEGEND			
UA	LEFT ARROW	UG	COMBO. LEFT/RIGHT/ STRAIGHT ARROW
UB	RIGHT ARROW	UI	ALPHANUMERIC CHARACTER
UC	STRAIGHT ARROW	UN	24" YIELD LINE TRIANGLE
UD	COMBO. LEFT/ STRAIGHT ARROW	UP	MERGE ARROW
UE	COMBO. RIGHT/ STRAIGHT ARROW	UT	U-TURN ARROW
UF	COMBO. LEFT/ RIGHT ARROW		

**PAVEMENT MARKING DETAIL**

06/04/18  
 P:\TIP\Projects-R\3825B\Traffic\Signing\CADD\PM Plan\3825b\_pmp\_psh\_s15.dgn  
 User:rtward



SEAL

**DOCUMENT NOT CONSIDERED FINAL  
UNLESS ALL SIGNATURES COMPLETED**

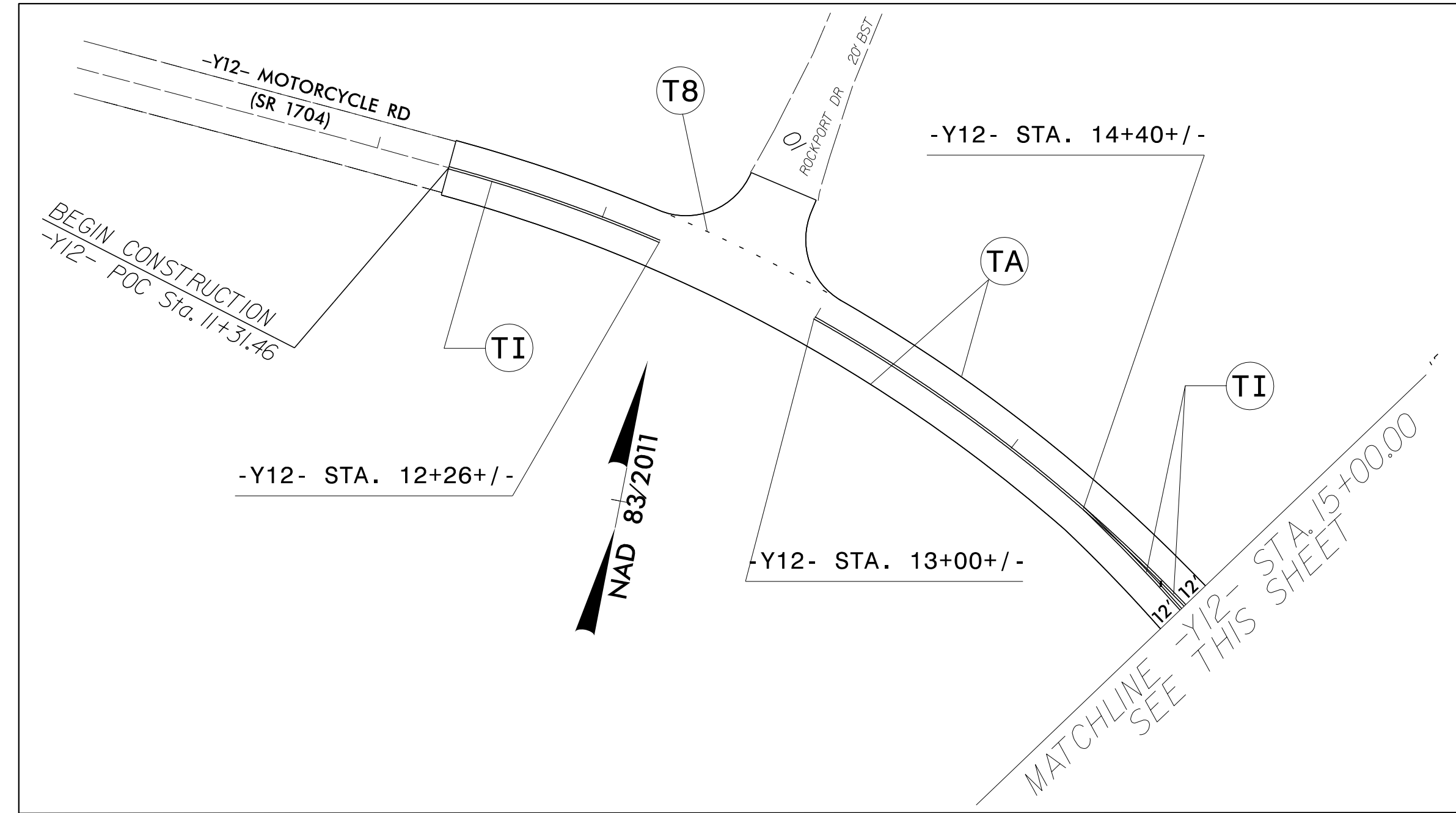
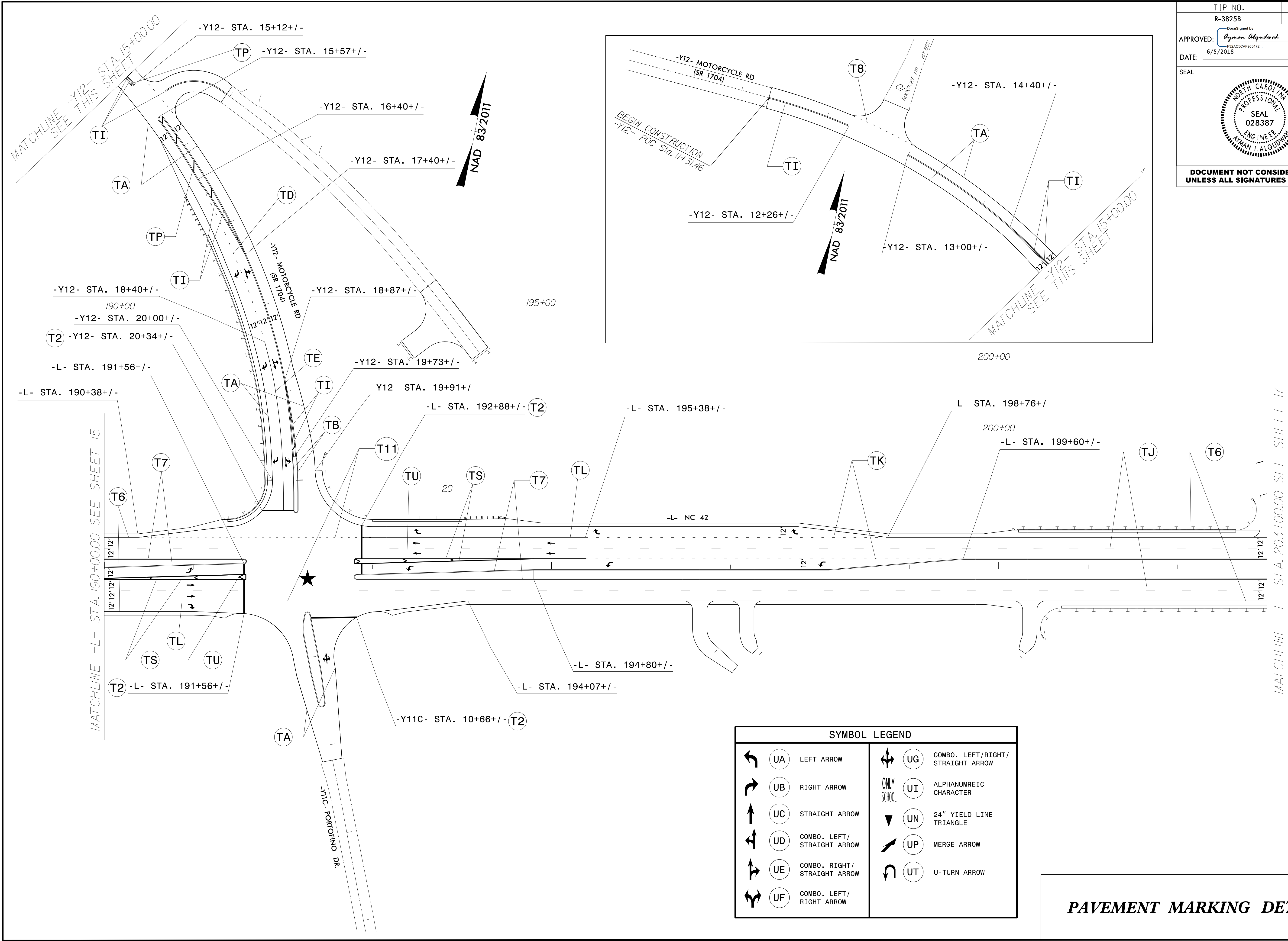

SYMBOL LEGEND					
	UA	LEFT ARROW		UG	COMBO. LEFT/RIGHT/STRAIGHT ARROW
	UB	RIGHT ARROW		UI	ALPHANUMREIC CHARACTER
	UC	STRAIGHT ARROW		UN	24" YIELD LINE TRIANGLE
	UD	COMBO. LEFT/STRAIGHT ARROW		UP	MERGE ARROW
	UE	COMBO. RIGHT/STRAIGHT ARROW		UT	U-TURN ARROW
	UF	COMBO. LEFT/RIGHT ARROW			

**PAVEMENT MARKING DETAIL**

06/04/18  
 P:\TIP\Projects-R\R3825B\Traffic\Signing\CADD\PM Plan\R-3825b\_pmp\_psh\_slb.dgn  
 User:rtward

TIP NO. R-3825B	SHEET NO. PMP-17
APPROVED: <i>Uyman Alquodwah</i> <small>F32ACSCAP985472...</small> DATE: 6/5/2018	
SEAL 	
<b>DOCUMENT NOT CONSIDERED FINAL UNLESS ALL SIGNATURES COMPLETED</b>	

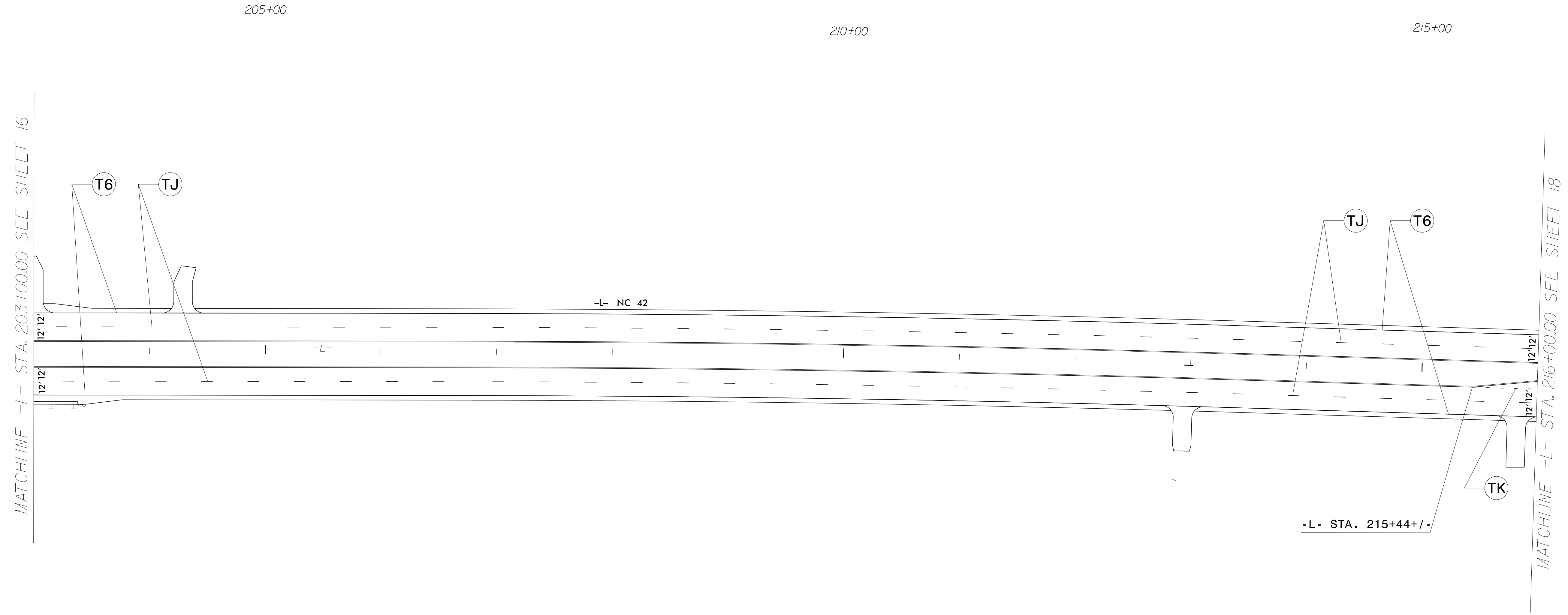
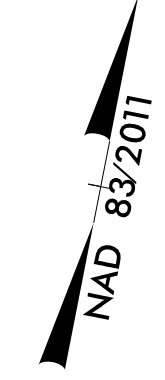

SYMBOL LEGEND			
UA	LEFT ARROW	UG	COMBO. LEFT/RIGHT/ STRAIGHT ARROW
UB	RIGHT ARROW	ONLY SCHOOL	ALPHANUMREIC CHARACTER
UC	STRAIGHT ARROW	UN	24" YIELD LINE TRIANGLE
UD	COMBO. LEFT/ STRAIGHT ARROW	UP	MERGE ARROW
UE	COMBO. RIGHT/ STRAIGHT ARROW	UT	U-TURN ARROW
UF	COMBO. LEFT/ RIGHT ARROW		

**PAVEMENT MARKING DETAIL**

06/04/18  
 P:\TIP\Projects-R\3825B\Traffic\Signing\CADD\PM Plan\3825b\_pmp\_psh\_sl7.dgn  
 User:rlward

APPROVED: *Osman Alqudwah*  
F32ACSCAF985472  
 DATE: 6/5/2018

SEAL



**DOCUMENT NOT CONSIDERED FINAL  
UNLESS ALL SIGNATURES COMPLETED**

SYMBOL LEGEND					
	UA	LEFT ARROW		UG	COMBO. LEFT/RIGHT/ STRAIGHT ARROW
	UB	RIGHT ARROW		UI	ALPHANUMERIC CHARACTER
	UC	STRAIGHT ARROW		UN	24" YIELD LINE TRIANGLE
	UD	COMBO. LEFT/ STRAIGHT ARROW		UP	MERGE ARROW
	UE	COMBO. RIGHT/ STRAIGHT ARROW		UT	U-TURN ARROW
	UF	COMBO. LEFT/ RIGHT ARROW			

\*\*DUE TO THE COMPLEX NATURE OF SIDEWALKS AND STREETScape PLANS THE CURB RAMP ARE SHOWN AS A GUIDE. REFER TO THE STREETScape AND ALTERNATE CURB RAMP DESIGNS IN THE ROADWAY PLANS.

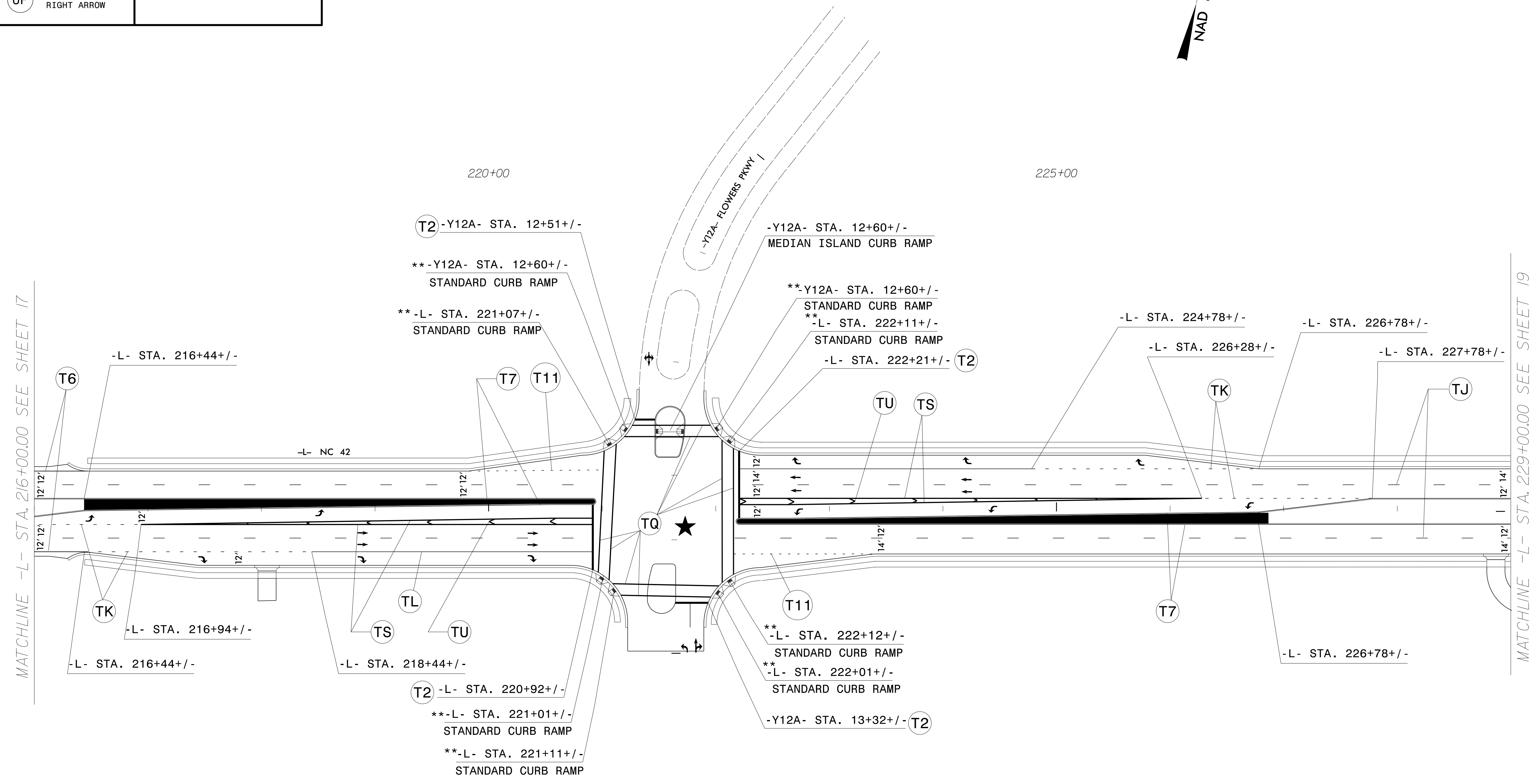
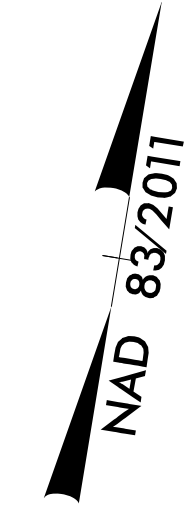

06/04/18  
 P:\TIP\Projects-R\R3825B\Traffic\Signing\CADD\PM Plan\R-3825b\_pmp\_psh\_slb.dgn  
 User:rtward

**PAVEMENT MARKING DETAIL**



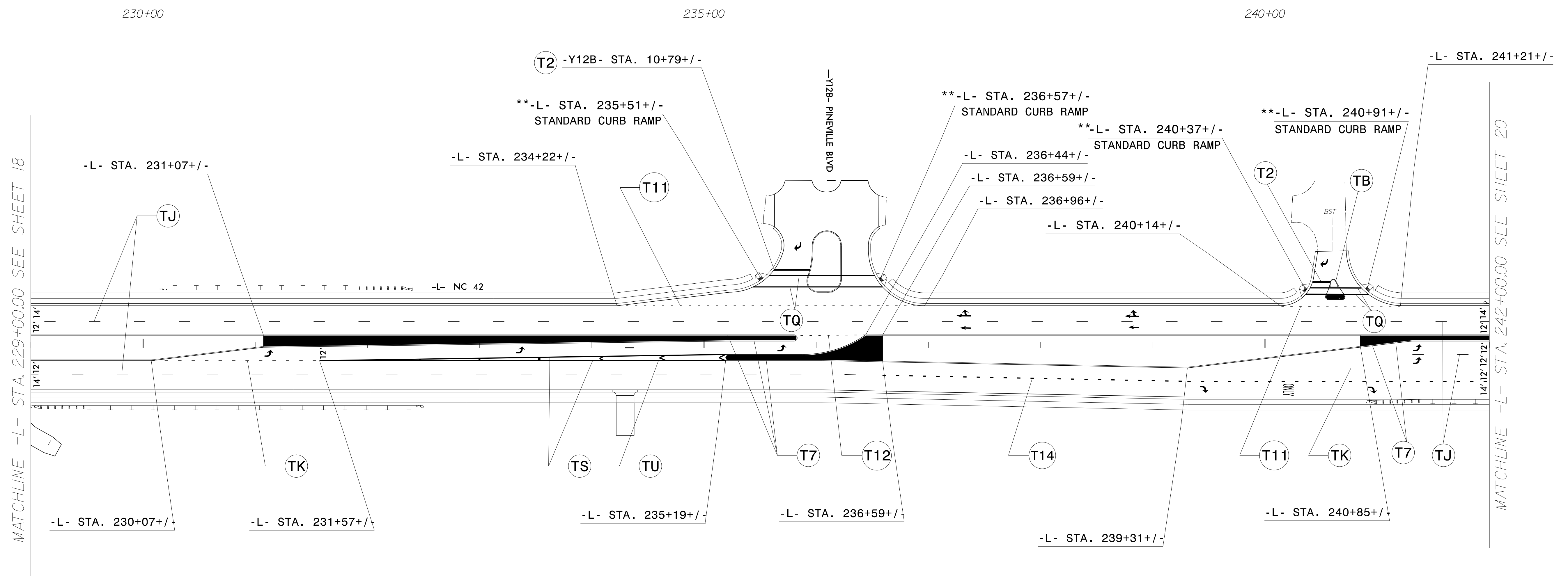

SYMBOL LEGEND					
	UA	LEFT ARROW		UG	COMBO. LEFT/RIGHT/ STRAIGHT ARROW
	UB	RIGHT ARROW		UI	ALPHANUMREIC CHARACTER
	UC	STRAIGHT ARROW		UN	24" YIELD LINE TRIANGLE
	UD	COMBO. LEFT/ STRAIGHT ARROW		UP	MERGE ARROW
	UE	COMBO. RIGHT/ STRAIGHT ARROW		UT	U-TURN ARROW
	UF	COMBO. LEFT/ RIGHT ARROW			

\*\*DUE TO THE COMPLEX NATURE OF SIDEWALKS AND STREETScape PLANS THE CURB RAMPS ARE SHOWN AS A GUIDE. REFER TO THE STREETScape AND ALTERNATE CURB RAMP DESIGNS IN THE ROADWAY PLANS.

**PAVEMENT MARKING DETAIL**

06/04/18  
 P:\TIP\Projects-R\R3825B\Traffic\Signing\CADD\PM Plan\R-3825b\_pmp\_sj19.dgn  
 User:rtward

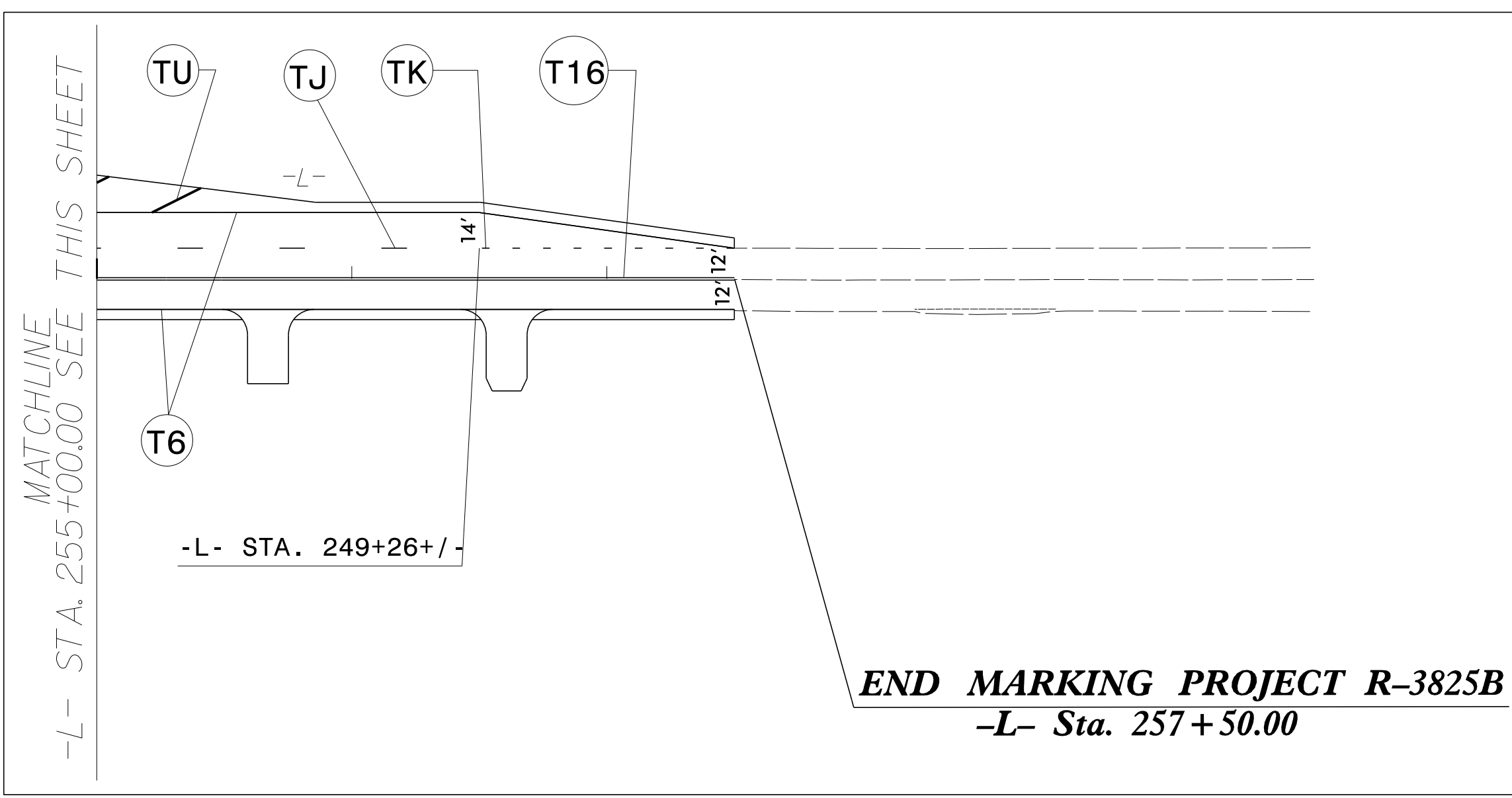
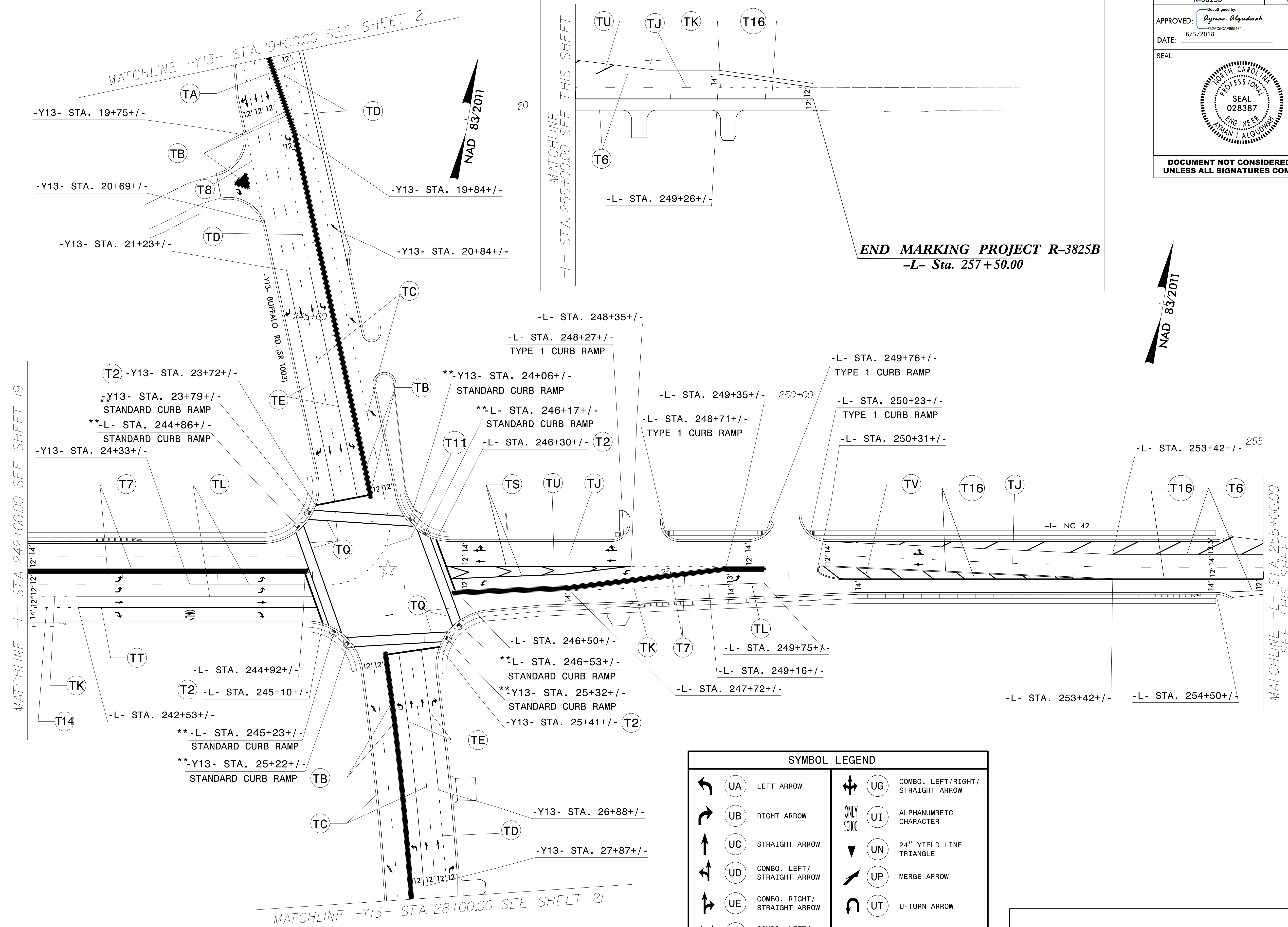

SYMBOL LEGEND			
	UA LEFT ARROW		UG COMBO. LEFT/RIGHT/STRAIGHT ARROW
	UB RIGHT ARROW		UI ALPHANUMERIC CHARACTER
	UC STRAIGHT ARROW		UN 24" YIELD LINE TRIANGLE
	UD COMBO. LEFT/STRAIGHT ARROW		UP MERGE ARROW
	UE COMBO. RIGHT/STRAIGHT ARROW		UT U-TURN ARROW
	UF COMBO. LEFT/RIGHT ARROW		

\*\*DUE TO THE COMPLEX NATURE OF SIDEWALKS AND STREETSCAPE PLANS THE CURB RAMP ARE SHOWN AS A GUIDE. REFER TO THE STREETSCAPE AND ALTERNATE CURB RAMP DESIGNS IN THE ROADWAY PLANS.

**PAVEMENT MARKING DETAIL**

06/04/18  
 P:\TIP\Projects-R\R3825B\Traffic\Signing\CADD\PM Plan\R-3825b\_pmp\_psh\_s20.dgn  
 User:rtward



NAD 83/2011

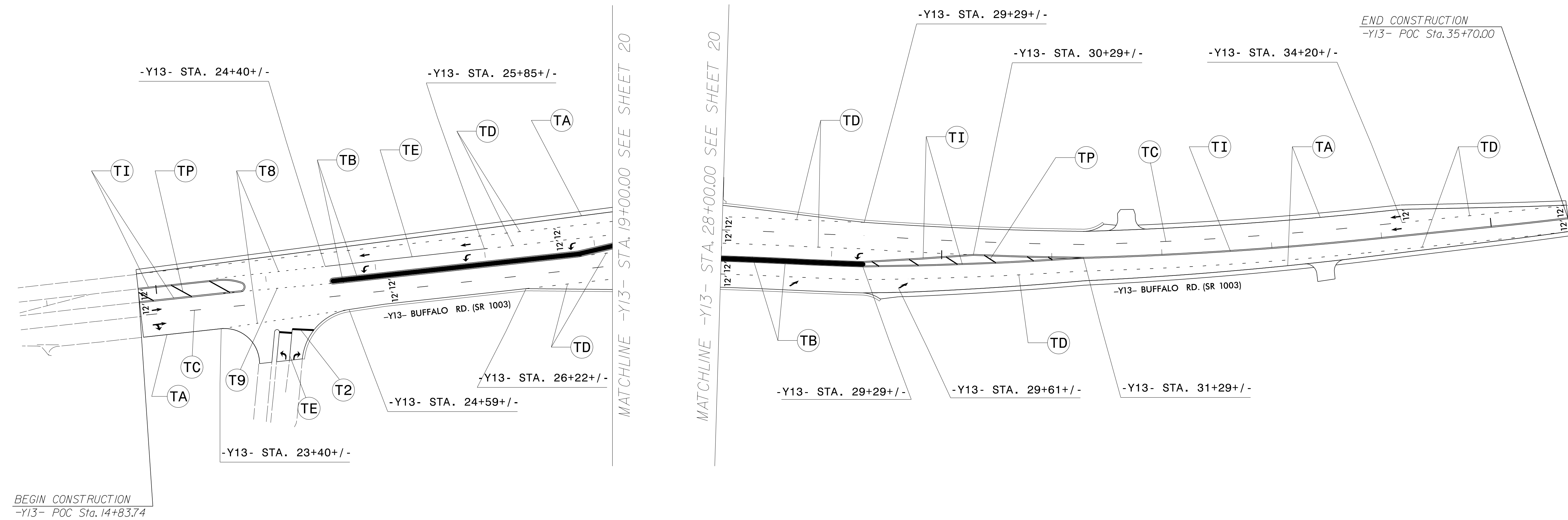

SYMBOL LEGEND	
	UA LEFT ARROW
	UB RIGHT ARROW
	UC STRAIGHT ARROW
	UD COMBO. LEFT/STRAIGHT ARROW
	UE COMBO. RIGHT/STRAIGHT ARROW
	UF COMBO. LEFT/RIGHT ARROW
	UG COMBO. LEFT/RIGHT/STRAIGHT ARROW
	ONLY SCHOOL UI ALPHANUMERIC CHARACTER
	UN 24" YIELD LINE TRIANGLE
	UP MERGE ARROW
	UT U-TURN ARROW

**PAVEMENT MARKING DETAIL**

06/04/18 P:\TIP\Projects-R\R3825B\Traffic\Signing\CADD\PM Plan\R-3825b\_pmp\_psh\_s21.dgn User:rtward