

REFERENCE: R-3825B

PROJECT: 34552

SEE SHEET 3 FOR PLAN SHEET LAYOUT  
AT TIME OF INVESTIGATION

**STATE OF NORTH CAROLINA**  
DEPARTMENT OF TRANSPORTATION  
DIVISION OF HIGHWAYS  
GEOTECHNICAL ENGINEERING UNIT

STATE	STATE PROJECT REFERENCE NO.	SHEET NO.	TOTAL SHEETS
N.C.	R-3825B	1	217

**CONTENTS**

<u>LINE</u>	<u>STATION</u>	<u>PLAN</u>
-L-	15+00 TO 257+50	4-22
-Y4-	10+00 TO 12+75	6
-Y5-	10+00 TO 14+22	7
-Y6-	10+60 TO 17+91	8
-Y7-	15+00 TO 17+35	9
-Y9-	11+73 TO 18+12	10
-Y10A-	11+10 TO 13+13	11
-Y10C-	12+05 TO 14+53	13
-Y11A-	10+00 TO 12+85	16
-Y11B-	10+00 TO 11+76	17
-Y12-	11+41 TO 21+00	18
-Y13-	14+84 TO 35+00	22-23

**CROSS SECTIONS**

<u>LINE</u>	<u>STATION</u>	<u>SHEET NO.</u>
-L-	15+00 TO 62+50	24-56
-L-	66+50 TO 257+70	57-177
-Y4-	10+50 TO 12+75	178-179
-Y5-	10+50 TO 14+22	180-182
-Y6-	10+50 TO 17+00	183-187
-Y7-	15+00 TO 16+50	188-189
-Y9-	11+74 TO 17+50	190-193
-Y10A-	11+10 TO 12+50	194-195
-Y10C-	12+05 TO 14+00	196-197
-Y11A-	10+50 TO 12+85	198-199
-Y11B-	10+50 TO 12+00	200-201
-Y12-	11+50 TO 20+50	202-207
-Y13-	14+84 TO 34+50	208-217

# ROADWAY SUBSURFACE INVESTIGATION

COUNTY JOHNSTON  
PROJECT DESCRIPTION NC 42 FROM EAST OF SR 1902  
(GLEN LAUREL ROAD) TO  
SR 1003 (BUFFALO ROAD)

## INVENTORY

**CAUTION NOTICE**

THE SUBSURFACE INFORMATION AND THE SUBSURFACE INVESTIGATION ON WHICH IT IS BASED WERE MADE FOR THE PURPOSE OF STUDY, PLANNING AND DESIGN, AND NOT FOR CONSTRUCTION OR PAY PURPOSES. THE VARIOUS FIELD BORING LOGS, ROCK CORES AND SOIL TEST DATA AVAILABLE MAY BE REVIEWED OR INSPECTED IN RALEIGH BY CONTACTING THE N. C. DEPARTMENT OF TRANSPORTATION, GEOTECHNICAL ENGINEERING UNIT AT (919) 707-6850. THE SUBSURFACE PLANS AND REPORTS, FIELD BORING LOGS, ROCK CORES AND SOIL TEST DATA ARE NOT PART OF THE CONTRACT.

GENERAL SOIL AND ROCK STRATA DESCRIPTIONS AND INDICATED BOUNDARIES ARE BASED ON A GEOTECHNICAL INTERPRETATION OF ALL AVAILABLE SUBSURFACE DATA AND MAY NOT NECESSARILY REFLECT THE ACTUAL SUBSURFACE CONDITIONS BETWEEN BORINGS OR BETWEEN SAMPLED STRATA WITHIN THE BOREHOLE. THE LABORATORY SAMPLE DATA AND THE IN SITU (IN-PLACE) TEST DATA CAN BE RELIED ON ONLY TO THE DEGREE OF RELIABILITY INHERENT IN THE STANDARD TEST METHOD. THE OBSERVED WATER LEVELS OR SOIL MOISTURE CONDITIONS INDICATED IN THE SUBSURFACE INVESTIGATIONS ARE AS RECORDED AT THE TIME OF THE INVESTIGATION. THESE WATER LEVELS OR SOIL MOISTURE CONDITIONS MAY VARY CONSIDERABLY WITH TIME ACCORDING TO CLIMATIC CONDITIONS INCLUDING TEMPERATURES, PRECIPITATION AND WIND, AS WELL AS OTHER NON-CLIMATIC FACTORS.

THE BIDDER OR CONTRACTOR IS CAUTIONED THAT DETAILS SHOWN ON THE SUBSURFACE PLANS ARE PRELIMINARY ONLY AND IN MANY CASES THE FINAL DESIGN DETAILS ARE DIFFERENT. FOR BIDDING AND CONSTRUCTION PURPOSES, REFER TO THE CONSTRUCTION PLANS AND DOCUMENTS FOR FINAL DESIGN INFORMATION ON THIS PROJECT. THE DEPARTMENT DOES NOT WARRANT OR GUARANTEE THE SUFFICIENCY OR ACCURACY OF THE INVESTIGATION MADE, NOR THE INTERPRETATIONS MADE, OR OPINION OF THE DEPARTMENT AS TO THE TYPE OF MATERIALS AND CONDITIONS TO BE ENCOUNTERED. THE BIDDER OR CONTRACTOR IS CAUTIONED TO MAKE SUCH INDEPENDENT SUBSURFACE INVESTIGATIONS AS HE DEEMS NECESSARY TO SATISFY HIMSELF AS TO CONDITIONS TO BE ENCOUNTERED ON THE PROJECT. THE CONTRACTOR SHALL HAVE NO CLAIM FOR ADDITIONAL COMPENSATION OR FOR AN EXTENSION OF TIME FOR ANY REASON RESULTING FROM THE ACTUAL CONDITIONS ENCOUNTERED AT THE SITE DIFFERING FROM THOSE INDICATED IN THE SUBSURFACE INFORMATION.

- NOTES:
1. THE INFORMATION CONTAINED HEREIN IS NOT IMPLIED OR GUARANTEED BY THE N. C. DEPARTMENT OF TRANSPORTATION AS ACCURATE NOR IS IT CONSIDERED PART OF THE PLANS, SPECIFICATIONS OR CONTRACT FOR THE PROJECT.
  2. BY HAVING REQUESTED THIS INFORMATION, THE CONTRACTOR SPECIFICALLY WAIVES ANY CLAIMS FOR INCREASED COMPENSATION OR EXTENSION OF TIME BASED ON DIFFERENCES BETWEEN THE CONDITIONS INDICATED HEREIN AND THE ACTUAL CONDITIONS AT THE PROJECT SITE.

PERSONNEL

GEOSYNTEC \_\_\_\_\_

GEOLOGIC EXPLORATION \_\_\_\_\_

CAROLINA DRILLING \_\_\_\_\_

INVESTIGATED BY NJOROGE WAINAINA

DRAWN BY CHLUCK TURLINGTON

CHECKED BY NJOROGE WAINAINA

SUBMITTED BY NJOROGE WAINAINA

DATE FEBRUARY 2017



DocuSigned by:  
Njoroge Wainaina 3/1/2017

\_\_\_\_\_  
SIGNATURE DATE

**DOCUMENT NOT CONSIDERED FINAL  
UNLESS ALL SIGNATURES COMPLETED**

**NORTH CAROLINA DEPARTMENT OF TRANSPORTATION  
DIVISION OF HIGHWAYS  
GEOTECHNICAL ENGINEERING UNIT  
SUBSURFACE INVESTIGATION  
SOIL AND ROCK LEGEND, TERMS, SYMBOLS, AND ABBREVIATIONS**

**SOIL DESCRIPTION**

SOIL IS CONSIDERED UNCONSOLIDATED, SEMI-CONSOLIDATED, OR WEATHERED EARTH MATERIALS THAT CAN BE PENETRATED WITH A CONTINUOUS FLIGHT POWER AUGER AND YIELD LESS THAN 100 BLOWS PER FOOT ACCORDING TO THE STANDARD PENETRATION TEST (AASHTO T 206, ASTM D1586). SOIL CLASSIFICATION IS BASED ON THE AASHTO SYSTEM. BASIC DESCRIPTIONS GENERALLY INCLUDE THE FOLLOWING: CONSISTENCY, COLOR, TEXTURE, MOISTURE, AASHTO CLASSIFICATION, AND OTHER PERTINENT FACTORS SUCH AS MINERALOGICAL COMPOSITION, ANGULARITY, STRUCTURE, PLASTICITY, ETC. FOR EXAMPLE, *VERY STIFF, GRAY, SILTY CLAY, MOIST WITH INTERBEDDED FINE SAND LAYERS, HIGHLY PLASTIC, A-7-6*

**SOIL LEGEND AND AASHTO CLASSIFICATION**

GENERAL CLASS.	GRANULAR MATERIALS (≤ 35% PASSING #200)							SILT-CLAY MATERIALS (> 35% PASSING #200)							ORGANIC MATERIALS								
	A-1	A-3	A-2	A-2-4	A-2-5	A-2-6	A-2-7	A-4	A-5	A-6	A-7	A-1, A-2	A-3	A-4, A-5	A-6, A-7								
GROUP CLASS.	A-1-a	A-1-b	A-2-4	A-2-5	A-2-6	A-2-7		A-4	A-5	A-6	A-7	A-1, A-2	A-3	A-4, A-5	A-6, A-7								
SYMBOL	[Pattern]							[Pattern]							[Pattern]								
% PASSING #10 #40 #200	50 MX 30 MX 15 MX	50 MX 25 MX	51 MN 35 MX	35 MX	35 MX	35 MX	35 MX	36 MN	36 MN	36 MN	36 MN	36 MN	36 MN										
MATERIAL PASSING #40 LL PI	[Table]							[Table]							[Table]								
GROUP INDEX	[Table]							[Table]							[Table]								
USUAL TYPES OF MAJOR MATERIALS	STONE FRAGS. GRAVEL, AND SAND		FINE SAND		SILTY OR CLAYEY GRAVEL AND SAND			SILTY SOILS		CLAYEY SOILS			SOILS WITH LITTLE OR MODERATE AMOUNTS OF ORGANIC MATTER			HIGHLY ORGANIC SOILS							
GEN. RATING AS SUBGRADE	EXCELLENT TO GOOD							FAIR TO POOR							FAIR TO POOR			POOR			UNSATURABLE		

PI OF A-7-5 SUBGROUP IS ≤ LL - 30 ; PI OF A-7-6 SUBGROUP IS > LL - 30

**CONSISTENCY OR DENSENESS**

PRIMARY SOIL TYPE	COMPACTNESS OR CONSISTENCY	RANGE OF STANDARD PENETRATION RESISTANCE (N-VALUE)	RANGE OF UNCONFINED COMPRESSIVE STRENGTH (TONS/FT <sup>2</sup> )
GENERALLY GRANULAR MATERIAL (NON-COHESIVE)	VERY LOOSE LOOSE MEDIUM DENSE DENSE VERY DENSE	< 4 4 TO 10 10 TO 30 30 TO 50 > 50	N/A
GENERALLY SILT-CLAY MATERIAL (COHESIVE)	VERY SOFT SOFT MEDIUM STIFF STIFF VERY STIFF HARD	< 2 2 TO 4 4 TO 8 8 TO 15 15 TO 30 > 30	< 0.25 0.25 TO 0.5 0.5 TO 1.0 1 TO 2 2 TO 4 > 4

**TEXTURE OR GRAIN SIZE**

U.S. STD. SIEVE SIZE OPENING (MM)	4	10	40	60	200	270
	4.76	2.00	0.42	0.25	0.075	0.053
BOULDER (BLDR.)						
COBBLE (COB.)						
GRAVEL (GR.)						
COARSE SAND (CSE. SD.)						
FINE SAND (F SD.)						
SILT (SL.)						
CLAY (CL.)						

**SOIL MOISTURE - CORRELATION OF TERMS**

SOIL MOISTURE SCALE (ATTERBERG LIMITS)	FIELD MOISTURE DESCRIPTION	GUIDE FOR FIELD MOISTURE DESCRIPTION
LL - LIQUID LIMIT	- SATURATED - (SAT.)	USUALLY LIQUID; VERY WET, USUALLY FROM BELOW THE GROUND WATER TABLE
PL - PLASTIC LIMIT	- WET - (W)	SEMISOLID; REQUIRES DRYING TO ATTAIN OPTIMUM MOISTURE
OM - OPTIMUM MOISTURE SHRINKAGE LIMIT	- MOIST - (M)	SOLID; AT OR NEAR OPTIMUM MOISTURE
SL - SHRINKAGE LIMIT	- DRY - (D)	REQUIRES ADDITIONAL WATER TO ATTAIN OPTIMUM MOISTURE

**PLASTICITY**

NON PLASTIC	PLASTICITY INDEX (PI)	DRY STRENGTH
SLIGHTLY PLASTIC	0-5	VERY LOW
MODERATELY PLASTIC	6-15	SLIGHT
HIGHLY PLASTIC	16-25	MEDIUM
	26 OR MORE	HIGH

**COLOR**

DESCRIPTIONS MAY INCLUDE COLOR OR COLOR COMBINATIONS (TAN, RED, YELLOW-BROWN, BLUE-GRAY). MODIFIERS SUCH AS LIGHT, DARK, STREAKED, ETC. ARE USED TO DESCRIBE APPEARANCE.

**GRADATION**

**WELL GRADED** - INDICATES A GOOD REPRESENTATION OF PARTICLE SIZES FROM FINE TO COARSE.  
**UNIFORMLY GRADED** - INDICATES THAT SOIL PARTICLES ARE ALL APPROXIMATELY THE SAME SIZE.  
**GAP-GRADED** - INDICATES A MIXTURE OF UNIFORM PARTICLE SIZES OF TWO OR MORE SIZES.

**ANGULARITY OF GRAINS**

THE ANGULARITY OR ROUNDNESS OF SOIL GRAINS IS DESIGNATED BY THE TERMS: ANGULAR, SUBANGULAR, SUBROUNDED, OR ROUNDED.

**MINERALOGICAL COMPOSITION**

MINERAL NAMES SUCH AS QUARTZ, FELDSPAR, MICA, TALC, KAOLIN, ETC. ARE USED IN DESCRIPTIONS WHEN THEY ARE CONSIDERED OF SIGNIFICANCE.

**COMPRESSIBILITY**

SLIGHTLY COMPRESSIBLE LL < 31  
MODERATELY COMPRESSIBLE LL = 31 - 50  
HIGHLY COMPRESSIBLE LL > 50

**PERCENTAGE OF MATERIAL**

ORGANIC MATERIAL	GRANULAR SOILS	SILT - CLAY SOILS	OTHER MATERIAL
TRACE OF ORGANIC MATTER	2 - 3%	3 - 5%	TRACE 1 - 10%
LITTLE ORGANIC MATTER	3 - 5%	5 - 12%	LITTLE 10 - 20%
MODERATELY ORGANIC	5 - 10%	12 - 20%	SOME 20 - 35%
HIGHLY ORGANIC	> 10%	> 20%	HIGHLY 35% AND ABOVE

**GROUND WATER**

- Water level in bore hole immediately after drilling
- Static water level after 24 hours
- Perched water, saturated zone, or water bearing strata
- Spring or seep

**MISCELLANEOUS SYMBOLS**

ROADWAY EMBANKMENT (RE) WITH SOIL DESCRIPTION

ARTIFICIAL FILL (AF) OTHER THAN ROADWAY EMBANKMENT

INFERRED SOIL BOUNDARY

INFERRED ROCK LINE

ALLUVIAL SOIL BOUNDARY

DIP & DIP DIRECTION OF ROCK STRUCTURES

TEST BORING

AUGER BORING

CORE BORING

MONITORING WELL

PIEZOMETER INSTALLATION

SLOPE INDICATOR INSTALLATION

CONE PENETROMETER TEST

SOUNDING ROD

TEST BORING WITH CORE

SPT N-VALUE

**RECOMMENDATION SYMBOLS**

UNDERCUT

SHALLOW UNDERCUT

UNCLASSIFIED EXCAVATION - UNSUITABLE WASTE

UNCLASSIFIED EXCAVATION - ACCEPTABLE DEGRADABLE ROCK

UNCLASSIFIED EXCAVATION - ACCEPTABLE, BUT NOT TO BE USED IN THE TOP 3 FEET OF EMBANKMENT OR BACKFILL

**ABBREVIATIONS**

- AR - AUGER REFUSAL
- BT - BORING TERMINATED
- CL - CLAY
- CPT - CONE PENETRATION TEST
- CSE - COARSE
- DMT - DILATOMETER TEST
- DPT - DYNAMIC PENETRATION TEST
- e - VOID RATIO
- F - FINE
- FOSS. - FOSSILIFEROUS
- FRAC. - FRACTURED, FRACTURES
- FRAGS. - FRAGMENTS
- HI. - HIGHLY
- MED. - MEDIUM
- MICA - MICACEOUS
- MOD. - MODERATELY
- NP - NON PLASTIC
- ORG. - ORGANIC
- PMT - PRESSUREMETER TEST
- SAP. - SAPROLITIC
- SD. - SAND, SANDY
- SL. - SILT, SILTY
- SLI. - SLIGHTLY
- TCR - TRICONE REFUSAL
- w - MOISTURE CONTENT
- V - VERY
- VST - VANE SHEAR TEST
- WEA. - WEATHERED
- UNIT WEIGHT
- DRY UNIT WEIGHT
- SAMPLE ABBREVIATIONS
- S - BULK
- SS - SPLIT SPOON
- ST - SHELBY TUBE
- RS - ROCK
- RT - RECOMPACTED TRIAXIAL
- CBR - CALIFORNIA BEARING RATIO

**EQUIPMENT USED ON SUBJECT PROJECT**

- DRILL UNITS:
  - CME-45C
  - CME-55
  - CME-550
  - VANE SHEAR TEST
  - PORTABLE HOIST
  - DIEDRICH D-50
- ADVANCING TOOLS:
  - CLAY BITS
  - 6" CONTINUOUS FLIGHT AUGER
  - 8" HOLLOW AUGERS
  - HARD FACED FINGER BITS
  - TUNG-CARBIDE INSERTS
  - CASING  W/ ADVANCER
  - TRICONE \*STEEL TEETH
  - TRICONE \*TUNG-CARB.
  - CORE BIT
- HAMMER TYPE:
  - AUTOMATIC  MANUAL
- CORE SIZE:
  - B
  - H
  - N
- HAND TOOLS:
  - POST HOLE DIGGER
  - HAND AUGER
  - SOUNDING ROD
  - VANE SHEAR TEST

**ROCK DESCRIPTION**

HARD ROCK IS NON-COASTAL PLAIN MATERIAL THAT WOULD YIELD SPT REFUSAL IF TESTED, AN INFERRED ROCK LINE INDICATES THE LEVEL AT WHICH NON-COASTAL PLAIN MATERIAL WOULD YIELD SPT REFUSAL. SPT REFUSAL IS PENETRATION BY A SPLIT SPOON SAMPLER EQUAL TO OR LESS THAN 0.1 FOOT PER 60 BLOWS IN NON-COASTAL PLAIN MATERIAL. THE TRANSITION BETWEEN SOIL AND ROCK IS OFTEN REPRESENTED BY A ZONE OF WEATHERED ROCK. ROCK MATERIALS ARE TYPICALLY DIVIDED AS FOLLOWS:

WEATHERED ROCK (WR)	NON-COASTAL PLAIN MATERIAL THAT WOULD YIELD SPT N VALUES > 100 BLOWS PER FOOT IF TESTED.
CRYSTALLINE ROCK (CR)	FINE TO COARSE GRAIN IGNEOUS AND METAMORPHIC ROCK THAT WOULD YIELD SPT REFUSAL IF TESTED. ROCK TYPE INCLUDES GRANITE, GNEISS, GABBRO, SCHIST, ETC.
NON-CRYSTALLINE ROCK (NCR)	FINE TO COARSE GRAIN METAMORPHIC AND NON-COASTAL PLAIN SEDIMENTARY ROCK THAT WOULD YIELD SPT REFUSAL IF TESTED. ROCK TYPE INCLUDES PHYLLITE, SLATE, SANDSTONE, ETC.
COASTAL PLAIN SEDIMENTARY ROCK (CP)	COASTAL PLAIN SEDIMENTS CEMENTED INTO ROCK, BUT MAY NOT YIELD SPT REFUSAL. ROCK TYPE INCLUDES LIMESTONE, SANDSTONE, CEMENTED SHELL BEDS, ETC.

**WEATHERING**

- FRESH** - ROCK FRESH, CRYSTALS BRIGHT, FEW JOINTS MAY SHOW SLIGHT STAINING. ROCK RINGS UNDER HAMMER IF CRYSTALLINE.
- VERY SLIGHT (IV SLI.)** - ROCK GENERALLY FRESH, JOINTS STAINED, SOME JOINTS MAY SHOW THIN CLAY COATINGS IF OPEN. CRYSTALS ON A BROKEN SPECIMEN FACE SHINE BRIGHTLY. ROCK RINGS UNDER HAMMER BLOWS IF OF A CRYSTALLINE NATURE.
- SLIGHT (SLI.)** - ROCK GENERALLY FRESH, JOINTS STAINED AND DISCOLORATION EXTENDS INTO ROCK UP TO 1 INCH. OPEN JOINTS MAY CONTAIN CLAY. IN GRANITOID ROCKS SOME OCCASIONAL FELDSPAR CRYSTALS ARE DULL AND DISCOLORED. CRYSTALLINE ROCKS RING UNDER HAMMER BLOWS.
- MODERATE (MOD.)** - SIGNIFICANT PORTIONS OF ROCK SHOW DISCOLORATION AND WEATHERING EFFECTS. IN GRANITOID ROCKS, MOST FELDSPARS ARE DULL AND DISCOLORED, SOME SHOW CLAY. ROCK HAS DULL SOUND UNDER HAMMER BLOWS AND SHOWS SIGNIFICANT LOSS OF STRENGTH AS COMPARED WITH FRESH ROCK.
- MODERATELY SEVERE (MOD. SEV.)** - ALL ROCK EXCEPT QUARTZ DISCOLORED OR STAINED. IN GRANITOID ROCKS, ALL FELDSPARS DULL AND DISCOLORED AND A MAJORITY SHOW KAOLINIZATION. ROCK SHOWS SEVERE LOSS OF STRENGTH AND CAN BE EXCAVATED WITH A GEOLOGIST'S PICK. ROCK GIVES "CLUNK" SOUND WHEN STRUCK. *IF TESTED, WOULD YIELD SPT REFUSAL*
- SEVERE (SEV.)** - ALL ROCK EXCEPT QUARTZ DISCOLORED OR STAINED. ROCK FABRIC CLEAR AND EVIDENT BUT REDUCED IN STRENGTH TO STRONG SOIL. IN GRANITOID ROCKS ALL FELDSPARS ARE KAOLINIZED TO SOME EXTENT. SOME FRAGMENTS OF STRONG ROCK USUALLY REMAIN. *IF TESTED, WOULD YIELD SPT N VALUES > 100 BPF*
- VERY SEVERE (IV SEV.)** - ALL ROCK EXCEPT QUARTZ DISCOLORED OR STAINED. ROCK FABRIC ELEMENTS ARE DISCERNIBLE BUT MASS IS EFFECTIVELY REDUCED TO SOIL STATUS, WITH ONLY FRAGMENTS OF STRONG ROCK REMAINING. SAPROLITE IS AN EXAMPLE OF ROCK WEATHERED TO A DEGREE THAT ONLY MINOR VESTIGES OF ORIGINAL ROCK FABRIC REMAIN. *IF TESTED, WOULD YIELD SPT N VALUES < 100 BPF*
- COMPLETE** - ROCK REDUCED TO SOIL. ROCK FABRIC NOT DISCERNIBLE, OR DISCERNIBLE ONLY IN SMALL AND SCATTERED CONCENTRATIONS. QUARTZ MAY BE PRESENT AS DIKES OR STRINGERS. SAPROLITE IS ALSO AN EXAMPLE.

**ROCK HARDNESS**

- VERY HARD** - CANNOT BE SCRATCHED BY KNIFE OR SHARP PICK. BREAKING OF HAND SPECIMENS REQUIRES SEVERAL HARD BLOWS OF THE GEOLOGIST'S PICK.
- HARD** - CAN BE SCRATCHED BY KNIFE OR PICK ONLY WITH DIFFICULTY. HARD HAMMER BLOWS REQUIRED TO DETACH HAND SPECIMEN.
- MODERATELY HARD** - CAN BE SCRATCHED BY KNIFE OR PICK. GOUGES OR GROOVES TO 0.25 INCHES DEEP CAN BE EXCAVATED BY HARD BLOW OF A GEOLOGIST'S PICK. HAND SPECIMENS CAN BE DETACHED BY MODERATE BLOWS.
- MEDIUM HARD** - CAN BE GROUDED OR GOUGED 0.25 INCHES DEEP BY FIRM PRESSURE OF KNIFE OR PICK POINT. CAN BE EXCAVATED IN SMALL CHIPS TO PIECES 1 INCH MAXIMUM SIZE BY HARD BLOWS OF THE POINT OF A GEOLOGIST'S PICK.
- SOFT** - CAN BE GROUDED OR GOUGED READILY BY KNIFE OR PICK. CAN BE EXCAVATED IN FRAGMENTS FROM CHIPS TO SEVERAL INCHES IN SIZE BY MODERATE BLOWS OF A PICK POINT. SMALL, THIN PIECES CAN BE BROKEN BY FINGER PRESSURE.
- VERY SOFT** - CAN BE CARVED WITH KNIFE. CAN BE EXCAVATED READILY WITH POINT OF PICK. PIECES 1 INCH OR MORE IN THICKNESS CAN BE BROKEN BY FINGER PRESSURE. CAN BE SCRATCHED READILY BY FINGER NAIL.

**FRACTURE SPACING**

TERM	SPACING	TERM	THICKNESS
VERY WIDE	MORE THAN 10 FEET	VERY THICKLY BEDDED	4 FEET
WIDE	3 TO 10 FEET	THICKLY BEDDED	1.5 - 4 FEET
MODERATELY CLOSE	1 TO 3 FEET	THINLY BEDDED	0.16 - 1.5 FEET
CLOSE	0.16 TO 1 FOOT	VERY THINLY BEDDED	0.03 - 0.16 FEET
VERY CLOSE	LESS THAN 0.16 FEET	THICKLY LAMINATED	0.008 - 0.03 FEET
		THINLY LAMINATED	< 0.008 FEET

**INDURATION**

- FRIABLE** - RUBBING WITH FINGER FREES NUMEROUS GRAINS; GENTLE BLOW BY HAMMER DISINTEGRATES SAMPLE.
- MODERATELY INDURATED** - GRAINS CAN BE SEPARATED FROM SAMPLE WITH STEEL PROBE; BREAKS EASILY WHEN HIT WITH HAMMER.
- INDURATED** - GRAINS ARE DIFFICULT TO SEPARATE WITH STEEL PROBE; DIFFICULT TO BREAK WITH HAMMER.
- EXTREMELY INDURATED** - SHARP HAMMER BLOWS REQUIRED TO BREAK SAMPLE; SAMPLE BREAKS ACROSS GRAINS.

**TERMS AND DEFINITIONS**

- ALLUVIUM (ALLUV.)** - SOILS THAT HAVE BEEN TRANSPORTED BY WATER.
- AQUIFER** - A WATER BEARING FORMATION OR STRATA.
- ARENACEOUS** - APPLIED TO ROCKS THAT HAVE BEEN DERIVED FROM SAND OR THAT CONTAIN SAND.
- ARGILLACEOUS** - APPLIED TO ALL ROCKS OR SUBSTANCES COMPOSED OF CLAY MINERALS, OR HAVING A NOTABLE PROPORTION OF CLAY IN THEIR COMPOSITION, SUCH AS SHALE, SLATE, ETC.
- ARTESIAN** - GROUND WATER THAT IS UNDER SUFFICIENT PRESSURE TO RISE ABOVE THE LEVEL AT WHICH IT IS ENCOUNTERED, BUT WHICH DOES NOT NECESSARILY RISE TO OR ABOVE THE GROUND SURFACE.
- CALCAREOUS (CALC.)** - SOILS THAT CONTAIN APPRECIABLE AMOUNTS OF CALCIUM CARBONATE.
- COLLUVIUM** - ROCK FRAGMENTS MIXED WITH SOIL DEPOSITED BY GRAVITY ON SLOPE OR AT BOTTOM OF SLOPE.
- CORE RECOVERY (REC.)** - TOTAL LENGTH OF ALL MATERIAL RECOVERED IN THE CORE BARREL DIVIDED BY TOTAL LENGTH OF CORE RUN AND EXPRESSED AS A PERCENTAGE.
- DIKE** - A TABULAR BODY OF IGNEOUS ROCK THAT CUTS ACROSS THE STRUCTURE OF ADJACENT ROCKS OR CUTS MASSIVE ROCK.
- DIP** - THE ANGLE AT WHICH A STRATUM OR ANY PLANAR FEATURE IS INCLINED FROM THE HORIZONTAL.
- DIP DIRECTION (DIP AZIMUTH)** - THE DIRECTION OR BEARING OF THE HORIZONTAL TRACE OF THE LINE OF DIP, MEASURED CLOCKWISE FROM NORTH.
- FAULT** - A FRACTURE OR FRACTURE ZONE ALONG WHICH THERE HAS BEEN DISPLACEMENT OF THE SIDES RELATIVE TO ONE ANOTHER PARALLEL TO THE FRACTURE.
- FISSILE** - A PROPERTY OF SPLITTING ALONG CLOSELY SPACED PARALLEL PLANES.
- FLOAT** - ROCK FRAGMENTS ON SURFACE NEAR THEIR ORIGINAL POSITION AND DISLOADED FROM PARENT MATERIAL.
- FLOOD PLAIN (FP)** - LAND BORDERING A STREAM, BUILT OF SEDIMENTS DEPOSITED BY THE STREAM.
- FORMATION (FM)** - A MAPPABLE GEOLOGIC UNIT THAT CAN BE RECOGNIZED AND TRACED IN THE FIELD.
- JOINT** - FRACTURE IN ROCK ALONG WHICH NO APPRECIABLE MOVEMENT HAS OCCURRED.
- LEDGE** - A SHELF-LIKE RIDGE OR PROJECTION OF ROCK WHOSE THICKNESS IS SMALL COMPARED TO ITS LATERAL EXTENT.
- LENS** - A BODY OF SOIL OR ROCK THAT THINS OUT IN ONE OR MORE DIRECTIONS.
- MOTTLED (MOT.)** - IRREGULARLY MARKED WITH SPOTS OF DIFFERENT COLORS. MOTTLING IN SOILS USUALLY INDICATES POOR AERATION AND LACK OF GOOD DRAINAGE.
- PERCHED WATER** - WATER MAINTAINED ABOVE THE NORMAL GROUND WATER LEVEL BY THE PRESENCE OF AN INTERVENING IMPERVIOUS STRATUM.
- RESIDUAL (RES.) SOIL** - SOIL FORMED IN PLACE BY THE WEATHERING OF ROCK.
- ROCK QUALITY DESIGNATION (ROD)** - A MEASURE OF ROCK QUALITY DESCRIBED BY TOTAL LENGTH OF ROCK SEGMENTS EQUAL TO OR GREATER THAN 4 INCHES DIVIDED BY THE TOTAL LENGTH OF CORE RUN AND EXPRESSED AS A PERCENTAGE.
- SAPROLITE (SAP.)** - RESIDUAL SOIL THAT RETAINS THE RELIC STRUCTURE OR FABRIC OF THE PARENT ROCK.
- SILL** - AN INTRUSIVE BODY OF IGNEOUS ROCK OF APPROXIMATELY UNIFORM THICKNESS AND RELATIVELY THIN COMPARED WITH ITS LATERAL EXTENT, THAT HAS BEEN EMPLACED PARALLEL TO THE BEDDING OR SCHISTOSITY OF THE INTRUDED ROCKS.
- SLICKENSIDE** - POLISHED AND STRIATED SURFACE THAT RESULTS FROM FRICTION ALONG A FAULT OR SLIP PLANE.
- STANDARD PENETRATION TEST (PENETRATION RESISTANCE) (SPT)** - NUMBER OF BLOWS (N OR BPF) OF A 140 LB. HAMMER FALLING 30 INCHES REQUIRED TO PRODUCE A PENETRATION OF 1 FOOT INTO SOIL WITH A 2 INCH OUTSIDE DIAMETER SPLIT SPOON SAMPLER. SPT REFUSAL IS PENETRATION EQUAL TO OR LESS THAN 0.1 FOOT PER 60 BLOWS.
- STRATA CORE RECOVERY (SREC.)** - TOTAL LENGTH OF STRATA MATERIAL RECOVERED DIVIDED BY TOTAL LENGTH OF STRATUM AND EXPRESSED AS A PERCENTAGE.
- STRATA ROCK QUALITY DESIGNATION (SROD)** - A MEASURE OF ROCK QUALITY DESCRIBED BY TOTAL LENGTH OF ROCK SEGMENTS WITHIN A STRATUM EQUAL TO OR GREATER THAN 4 INCHES DIVIDED BY THE TOTAL LENGTH OF STRATA AND EXPRESSED AS A PERCENTAGE.
- TOPSOIL (TS.)** - SURFACE SOILS USUALLY CONTAINING ORGANIC MATTER.

**BENCH MARK:**

ELEVATION: FEET

**NOTES:**

FIAD = FILLED IN AFTER DRILLING  
SPT REF = STANDARD PENETRATION TEST REFUSAL

TIN FILE NAME "R3825b\_1s.tn1.tin" WITH FILE DATE 4-5-2016, WAS USED TO GENERATE BORING ELEVATIONS.

9/20/19

See Sheet 1A For Index of Sheets  
See Sheet 1B For Conventional Symbols

# STATE OF NORTH CAROLINA DIVISION OF HIGHWAYS

## JOHNSTON COUNTY

LOCATION: NC 42 FROM SR 1902 (GLEN LAUREL RD)  
TO SR 1003 (BUFFALO RD)

TYPE OF WORK: GRADING, PAVING, STRUCTURES,  
DRAINAGE AND SIGNALS

STATE	STATE PROJECT REFERENCE NO.	SHEET NO.	TOTAL SHEETS
N.C.	R-3825B	3	217
STATE PROJ. NO.	F.A. PROJ. NO.	DESCRIPTION	
34552.1.FR3	STP-0042(58)	P.E.	
DOCUMENT NOT CONSIDERED FINAL UNLESS ALL SIGNATURES COMPLETED			

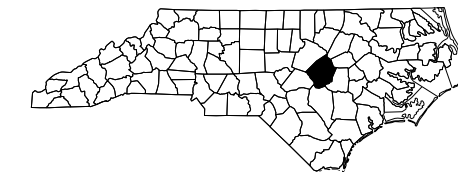

TIP PROJECT: R-3825B

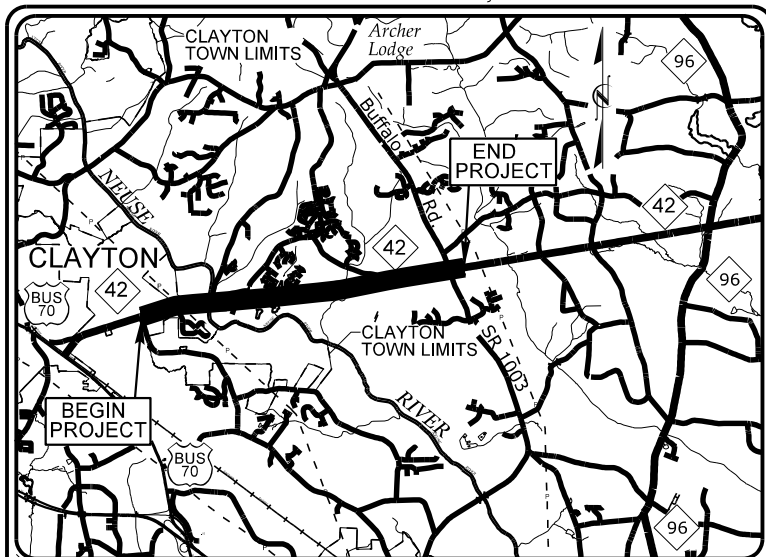

**VICINITY MAP**  
NOT TO SCALE

25% APPROVED PLANS

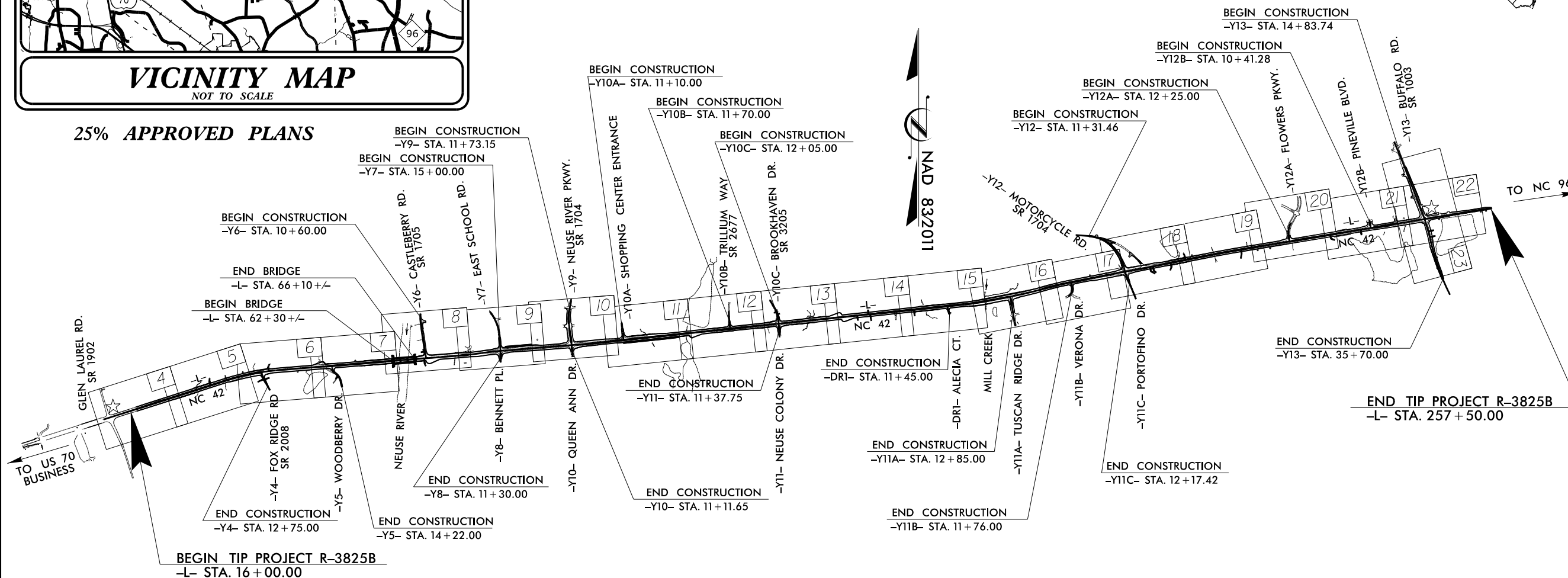

CLEARING ON THIS PROJECT WILL BE PERFORMED  
TO THE LIMITS ESTABLISHED BY NCDOT METHOD

INCOMPLETE PLANS  
DO NOT USE FOR R/W ACQUISITION  
DOCUMENT NOT CONSIDERED FINAL  
UNLESS ALL SIGNATURES COMPLETED

CONTRACT:

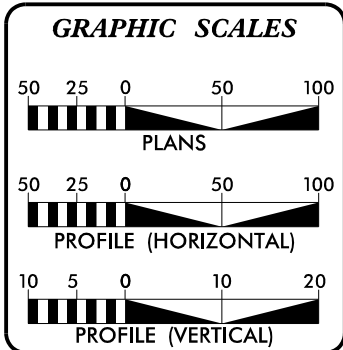

**DESIGN DATA**

ADT 2015 =	19,000
ADT 2040 =	37,400
K =	9%
D =	65%
T =	6% *
V =	60 MPH
* (TTST % + DUAL %)	
FUNC. CLASS =	RURAL
	MINOR ARTERIAL
	REGIONAL TIER
DESIGN EXCEPTION	(GRADE)

**PROJECT LENGTH**

LENGTH ROADWAY TIP PROJECT R-3825B =	4.521 MILES
LENGTH BRIDGE TIP PROJECT R-3825B =	0.072 MILES
TOTAL LENGTH OF TIP PROJECT R-3825B =	4.593 MILES

**URS**  
URS Corporation - North Carolina  
1600 Perimeter Park Drive  
Morrisville, North Carolina 27560  
TELEPHONE: (919) 461-1100 FAX: (919) 461-1415  
NC LICENSE # C-2043

2012 STANDARD SPECIFICATIONS	<b>ED EDENS, P.E.</b> PROJECT ENGINEER
RIGHT OF WAY DATE: JUNE 17, 2016	<b>KEVIN VAN METRE, P.E.</b> PROJECT DESIGN ENGINEER
LETTING DATE: JUNE 19, 2018	<b>GARY R. LOVERING, P.E.</b> PROJECT ENGINEER NCDOT ROADWAY DESIGN

**HYDRAULICS ENGINEER**

\_\_\_\_\_  
P.E.  
SIGNATURE:  
ROADWAY DESIGN ENGINEER

\_\_\_\_\_  
P.E.  
SIGNATURE:

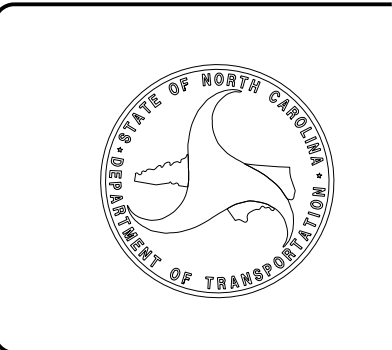

C:\NCDOT\19-R-3825B\19-3825B\_GEO.RDWY\_modif\ter\CADD\_GEO\TECH\19-R-3825B\_r.dwg\_tsh.dgn

February 22, 2017

WBS NUMBER           34552.1.FR3  
TIP NUMBER            R-3825B  
F. A. Proj.#:         STP-0042(58)  
COUNTY:             Johnston

DESCRIPTION:         NC 42 from East of SR 1902 (Glen Laurel Rd.) to SR 1003  
                              (Buffalo Road)

SUBJECT:              Geotechnical Report – Inventory

Geosyntec Consultants has completed a subsurface investigation for this project and present the following inventory.

**Project Description**

The project area lies east of the town of Clayton along the existing NC 42 beginning just east of Glen Laurel Road (Station 15+00) and extends eastward 4.6 miles to just east of Buffalo Road (Station 257+50). The proposed project consist of widening of the existing NC 42 from two lanes to four with median and turn lanes with multiple embankments of up to 30 feet and cut sections as deep as 30 feet. The widening will be accomplished by addition of two new travel lanes on the southern side of the existing NC 42 on majority of the roadway segments and addition of two new travel lanes on each side of the existing NC 42 in some roadway segments. Additionally, some widening and realignment is proposed for some of the intersecting -Y- lines.

The geotechnical investigation was conducted in March and April of 2016. Borings were advanced with ATV mounted Dietrich D50 and CME 45C drill machines. Both drill machines were equipped with automatic hammers. Standard Penetration tests were performed in all borings. Representative soil samples were collected for visual classification in the field and for laboratory analysis by Falcon Engineering.

The following alignments, totaling 5.5 miles were investigated. Subsurface cross sections of these alignments are included in this report.

<u>Line</u>	<u>Station</u>
-L-	15+00 to 257+50
-Y4-	10+00 to 12+75
-Y5-	10+00 to 14+22
-Y6-	10+60 to 17+91
-Y7-	15+00 to 17+35
-Y9-	11+73 to 18+12
-Y10A	11+10 to 13+13
-Y10C-	12+05 to 14+53
-Y11A-	10+00 to 12+85
-Y11B-	10+00 to 11+76
-Y12-	11+31 to 20+99
-Y13-	14+84 to 35+70

**Physiography and Geology**

The portion of the project corridor west of the Neuse River is within the Piedmont Physiographic Province and the portion east of the Neuse River is within the boundary of the Piedmont Province and the Coastal Plain Physiographic Province. Surficial soils within the Piedmont Province consist of residual sandy silts derived from weathering of the underlying metamorphic rocks of the Raleigh Belt. Within the Coastal Plain Province, the surficial soils consist of Terrace deposits and Upland sediments consisting of gravel, sands, clayey sands, sandy silts and sandy clays. The Coastal Plain surficial soils are underlain by the residual soils of the Piedmont Province.

The topography west of the Neuse River is generally sloping down towards the river. The elevation at the beginning of the project is approximately 310± feet and decreases to approximately 140± feet on the west bank of the Neuse River. The topography east of the Neuse River is generally rolling and ranges in elevation from a high of approximately 310± feet to approximately 150± feet. Surface waters generally flows towards the Neuse River and surface drainage is generally good.

**Soil Properties**

Soils encountered in this project have been divided into five categories, 1) roadway embankment 2) alluvial soils, 3) Coastal Plain soils, 4) residual soils, 5) artificial fill.



Roadway embankment soils are present along existing NC 42. They typically consist of red, brown, soft to medium stiff, moist, sandy and clayey silts (A-4 and A-5) and loose to medium dense, moist, silty sands (A-2-4 and A-2-5).

Alluvial soils are encountered throughout the project along the flood plains of the Neuse river, creeks and adjacent to wetlands. Alluvial soils are either present on the surface or under roadway embankment soils. These soils consist of tan, gray, red and brown loose to medium dense, moist, gravelly sands (A-1-a and A-1-b), and red, brown, soft to stiff, moist, sandy silts, sandy clays and silty clays (A-4, A-6 and A-7-6). These soils range in thickness from 2± to 6± feet.

Coastal Plain soils were encountered east of the Neuse River either on the surface, or under the roadway embankment or alluvial soils. Coastal plain deposits range in thickness from 2± to 10± feet. They consist of brown, red and gray, very loose to medium dense, moist, silty and clayey sands (A-2-4 and A-2-6) and soft to stiff, moist, sandy silts, sandy clays and silty clays (A-4, A-6 and A-7-6).

Residual soils were encountered throughout the project. Residual soils primarily consist of red, yellow and brown, medium stiff to very stiff, moist, sandy and clayey silts (A-4 and A-5) with trace weathered rock fragments.

Artificial fills are encountered in several areas along the -L- alignment and along -Y11B- and -Y13-. The artificial fill located on the right side, starting from Station 46+00 to 49+00 consist of red, brown, very loose to medium dense, moist, clayey sand (A-2-7) mixed with chunks of asphalt, concrete pavement materials, and concrete. The other areas of the artificial fill consist of soil materials including red and brown, loose to medium dense, moist, silty sand (A2-4) to clayey sand (A-2-6) and stiff to very stiff, moist, clayey and sandy silt (A-4) and (A-5).

#### Rock Properties

Weathered rock was encountered in deeper borings and some shallow borings in lower elevations. Weathered rock is derived from the weathering of the underlying schist. Crystalline rock was encountered at the following stations:

<u>Line</u>	<u>Stations</u>
-L-	58+75 to 59+25
-L-	61+75 to 62+75
-L-	106+25 to 107+25
-L-	135+25 to 135+75

-L-	155+75 to 156+75
-L-	165+25 to 165+75
-L-	166+25 to 157+25

#### Ground Water

Ground water data was collected during March and April of 2016, during a time of normal precipitation. Ground water occurs in low lying areas and adjacent to bodies of water at depths ranging from 0 to 15 feet from the existing ground surface elevation. Seasonal fluctuations of the ground water table should be anticipated.

Seeps: One area where water was seeping at the interface between the embankment and natural ground was noted at the following stations:

<u>Line</u>	<u>Station(±)</u>	<u>Offsets</u>
-L-	60+80 to 62+00	RT

Water Wells: Water wells were noted within or in close proximity to the construction limits at the following locations:

<u>Line</u>	<u>Stations</u>	<u>Offsets</u>
-L-	44+60	39' RT
-L-	162+60	70' RT
-L-	163+35	65' RT
-L-	184+75	39' LT
-L-	236+10	60' RT

Ponds: Three ponds were noted within the construction limit at the following location:

<u>Line</u>	<u>Stations</u>	<u>Offsets</u>
-L-	116+50 to 118+50	LT
-L-	200+50 to 202+50	LT
-L-	248+50 to 249+50	RT

**Areas of Special Geotechnical Interest**

1) High Ground Water: Ground water was encountered within 6 feet of final grade at the following locations:

<u>Line</u>	<u>Station</u>	<u>Offsets</u>
-L-	41+75 to 43+25	RT
-L-	75+25 to 76+75	LT
-L-	79+75 to 82+25	LT and RT
-L-	110+25 to 113+25	LT and RT
-L-	234+25 to 236+25	LT and RT
-L-	243+75 to 248+75	LT and RT
-L-	251+00 to 253+25	LT and RT
-L-	255+50 to 257+75	LT and RT
-Y7-	14+75 to 16+50	LT and RT

2) Artificial Fill: Areas of artificial fill were encountered at the following locations:

<u>Line</u>	<u>Station</u>	<u>Offsets</u>
-L-	46+00 to 51+50	RT
-L-	95+00 to 100+00	LT
-L-	107+00 to 109+00	RT
-L-	112+17 to 114+00	RT
-L-	117+00 to 119+00	LT
-L-	154+45 to 155+45	LT
-L-	167+70 to 170+80	RT
-L-	172+50 to 182+00	RT
-L-	183+00 to 186+00	RT
-L-	199+60 to 200+50	LT
-L-	201+00 to 202+00	LT
-L-	207+25 to 208+25	LT
-L-	213+25 to 213+75	LT
-L-	215+50 to 217+00	LT
-L-	248+75 to 250+00	LT
-Y6-	13+25 to 16+25	LT
-Y11B-	10+70 to 12+20	RT
-Y13-	21+00 to 22+50	RT

3) Soft Soils: The following areas were found to contain soft clay soils

<u>Line</u>	<u>Station</u>	<u>Offsets</u>
-L-	25+50 to 29+00	LT and RT
-L-	66+50 to 67+50	LT and RT
-L-	75+25 to 77+00	LT
-L-	85+50 to 88+00	LT and RT
-L-	136+50 to 137+00	RT
-L-	165+50 to 166+50	LT and RT
-L-	230+00 to 233+50	LT and RT

4) High Plastic Clays: Clay soils with high plasticity (PI > 15) were encountered either within three feet of final grade or above final grade in cut areas at the following locations:

<u>Line</u>	<u>Station</u>	<u>Offsets</u>
-L-	77+00 to 79+50	RT and LT
-L-	82+00 to 83+50	LT and RT
-L-	92+50 to 94+50	LT and RT
-L-	177+50 to 181+00	LT and RT
-L-	207+00 to 208+50	RT
-L-	214+75 to 215+75	RT
-L-	217+80 to 218+50	LT and RT
-L-	220+50 to 222+00	LT
-L-	224+00 to 226+00	LT and RT
-L-	243+00 to 246+50	LT and RT
-L-	251+50 to 253+00	LT and RT
-Y6-	14+00 to 15+25	LT
-Y7-	14+50 to 16+50	LT and RT

**Culverts**

Culvert at -L- 107+30

Natural ground elevations range from 160± feet at the bottom of the stream to 170± feet along the adjacent floodplain. Borings completed in the vicinity show approximately 5± feet of very loose alluvial clayey sand (A-2-6) underlain by weathered rock. Ground water was measured at an elevation of 157± feet during this investigation.

Culvert at -L- 114+10

Natural ground elevations range from 147± feet at the bottom of the stream to 170± feet along the adjacent floodplain. Borings completed in the vicinity show approximately 10± feet of very loose alluvial clayey sand (A-2-6) underlain by 10± feet of very loose Coastal Plain clayey sand (A-2-6) and very soft to soft sandy clay (A-6) and weathered rock. Ground water was measured at an elevation of 153± feet during this investigation.

Culvert at -L- 135+50

Natural ground elevations range from 165± feet at the bottom of the stream to 177± feet along the adjacent floodplain. The boring on the downstream side show approximately 5± feet of very loose to loose alluvial clayey sand (A-2-6) underlain by weathered rock. The boring on the upstream side show approximately 18± feet of very stiff to hard residual sandy silt (A-4) and dense to very dense gravelly sand (A-1-a) and silty sand (A-2-4) underlain by weathered rock. Ground water was measured at an elevation of 165± feet during this investigation.

Culvert at -L- 156+30

Natural ground elevations range from 160± feet at the bottom of the stream to 180± feet along the adjacent floodplain. The borings completed in the vicinity show approximately 6± feet of soft to stiff alluvial clayey sand (A-2-6) underlain by 15± feet of stiff to hard residual sandy silt (A-4) and weathered rock. Ground water was measured at an elevation of 157± feet during this investigation.

Culvert at -L- 167+10

Natural ground elevations range from 150± feet at the bottom of the stream to 155± feet along the adjacent floodplain. The borings completed in the vicinity show approximately 5± feet of soft to medium stiff alluvial clayey sand (A-2-6) underlain by 10± feet of hard residual sandy silt (A-4) and weathered rock. Ground water was measured at an elevation of 154± feet during this investigation.

**Stream Relocation**

Stream Relocation at -L- 73+20 to 76+50

A jurisdictional stream that drains into a 24" RCP at Station 73+20 will require relocation to an alignment outside of the proposed embankment slope stakes. The borings in the vicinity of the proposed alignment show approximately 10± feet of medium stiff to very stiff, alluvial, sandy clays (A-6) underlain by medium stiff to hard, residual, sandy silt (A-4). Shallow ground water less than 4± feet was encountered at the boring closest to the proposed alignment.

Stream Relocation at -L- 135+50 to 137+00

A jurisdictional stream that drains into the culvert at Station 135+50 will require relocation to an alignment outside of the proposed embankment slope stakes. The borings in the vicinity of the proposed alignment show approximately 3± feet of very loose to loose, alluvial, clayey sands (A-2-6) underlain by very stiff, residual, sandy silt (A-4). Shallow ground water less than 4± feet was encountered at the boring closest to the proposed alignment.

Stream Relocation at -L- 167+00 to 171+00

A jurisdictional stream that drains into the culvert at Station 167+10 will require relocation to an alignment outside of the proposed embankment slope stakes. The borings in the vicinity of the proposed alignment show approximately 7± feet of soft to medium stiff, alluvial, sandy silts (A-4) underlain by medium stiff, residual, sandy silt (A-4).

Prepared by

Njoroge Wainaina  
Senior Consultant

**APPENDIX A**

**Undisturbed and Bulk Samples**

Undisturbed Samples: Undisturbed thin wall Shelby tube samples were collected at the following locations and submitted for testing.

<u>Sample No.</u>	<u>Station</u>	<u>Depth (ft)</u>	<u>Test</u>
ST-1	49+50, 35' RT	9.0-11.0	Consolidation, Triaxial CU
ST-2	28+00, 44' LT	7.0-9.0	Consolidation, Triaxial CU

Bulk samples were collected at the following locations and submitted for testing.

<u>Sample No.</u>	<u>Station</u>	<u>Depth (ft)</u>	<u>Test</u>
BS-1	53+50, 55' RT and 55+00, 55RT	5.0 to 32.0	CBR
BS-2	51+50, 65' LT	8.0 to 10.0	CBR





PROJECT REFERENCE NO. <b>R-3825B</b>	SHEET NO. <b>5</b>
RW SHEET NO.	
ROADWAY DESIGN ENGINEER	HYDRAULICS ENGINEER
<b>INCOMPLETE PLANS</b> DO NOT USE FOR R/W ACQUISITION	
<b>DOCUMENT NOT CONSIDERED FINAL</b> UNLESS ALL SIGNATURES COMPLETED	

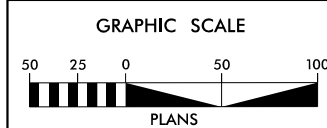
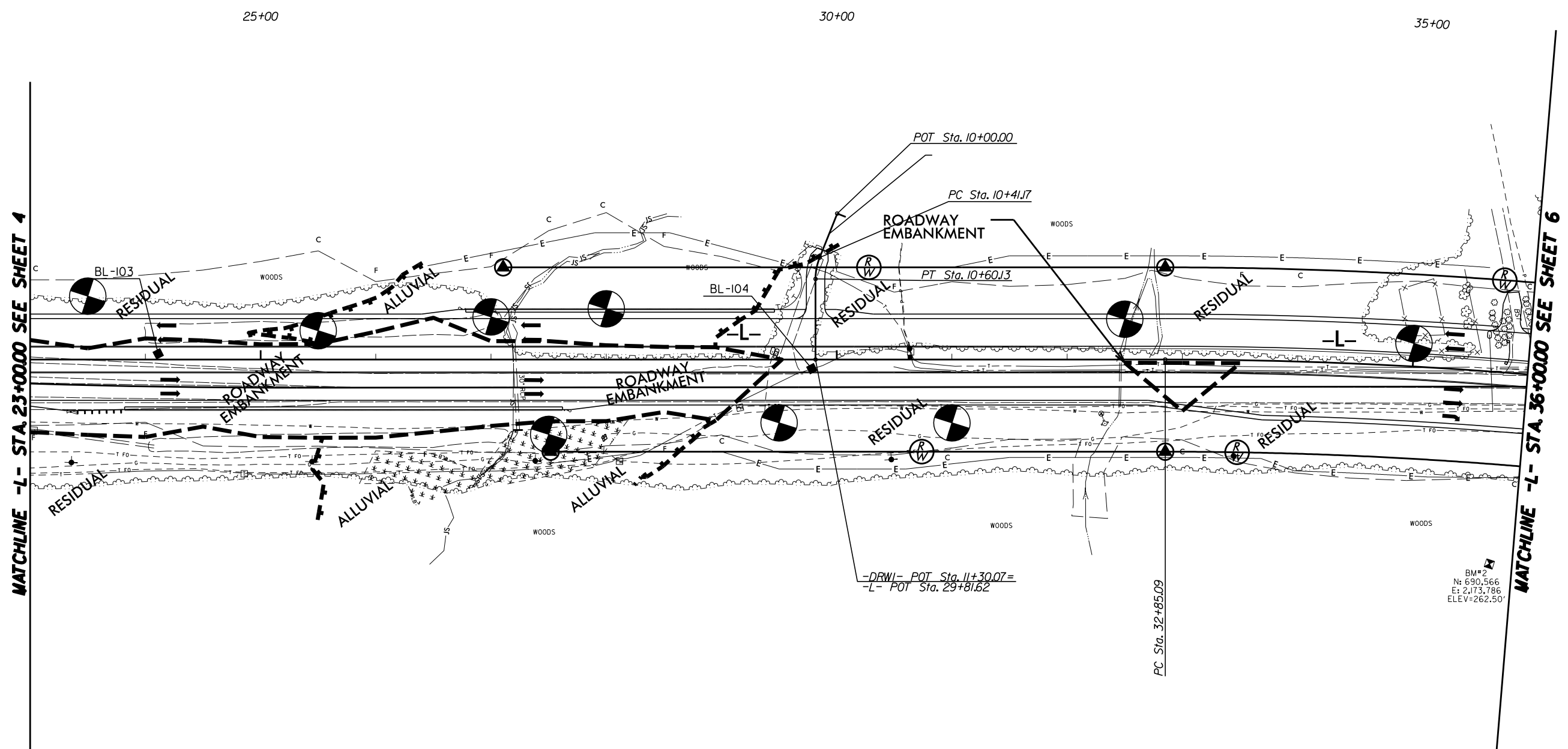

REVISIONS

8/17/09  
 8/31/2017  
 C:\Users\jpr\OneDrive\Documents\Projects\3825B\Plan\3825B\_Plan\3825B\_Plan.dgn  
 C:\Users\jpr\OneDrive\Documents\Projects\3825B\Plan\3825B\_Plan\3825B\_Plan.dgn  
 C:\Users\jpr\OneDrive\Documents\Projects\3825B\Plan\3825B\_Plan\3825B\_Plan.dgn

PROJECT REFERENCE NO. <b>R-3825B</b>	SHEET NO. <b>6</b>
RW SHEET NO.	
ROADWAY DESIGN ENGINEER	HYDRAULICS ENGINEER
<b>INCOMPLETE PLANS</b> DO NOT USE FOR R/W ACQUISITION	
<b>DOCUMENT NOT CONSIDERED FINAL</b> UNLESS ALL SIGNATURES COMPLETED	



40+00

45+00

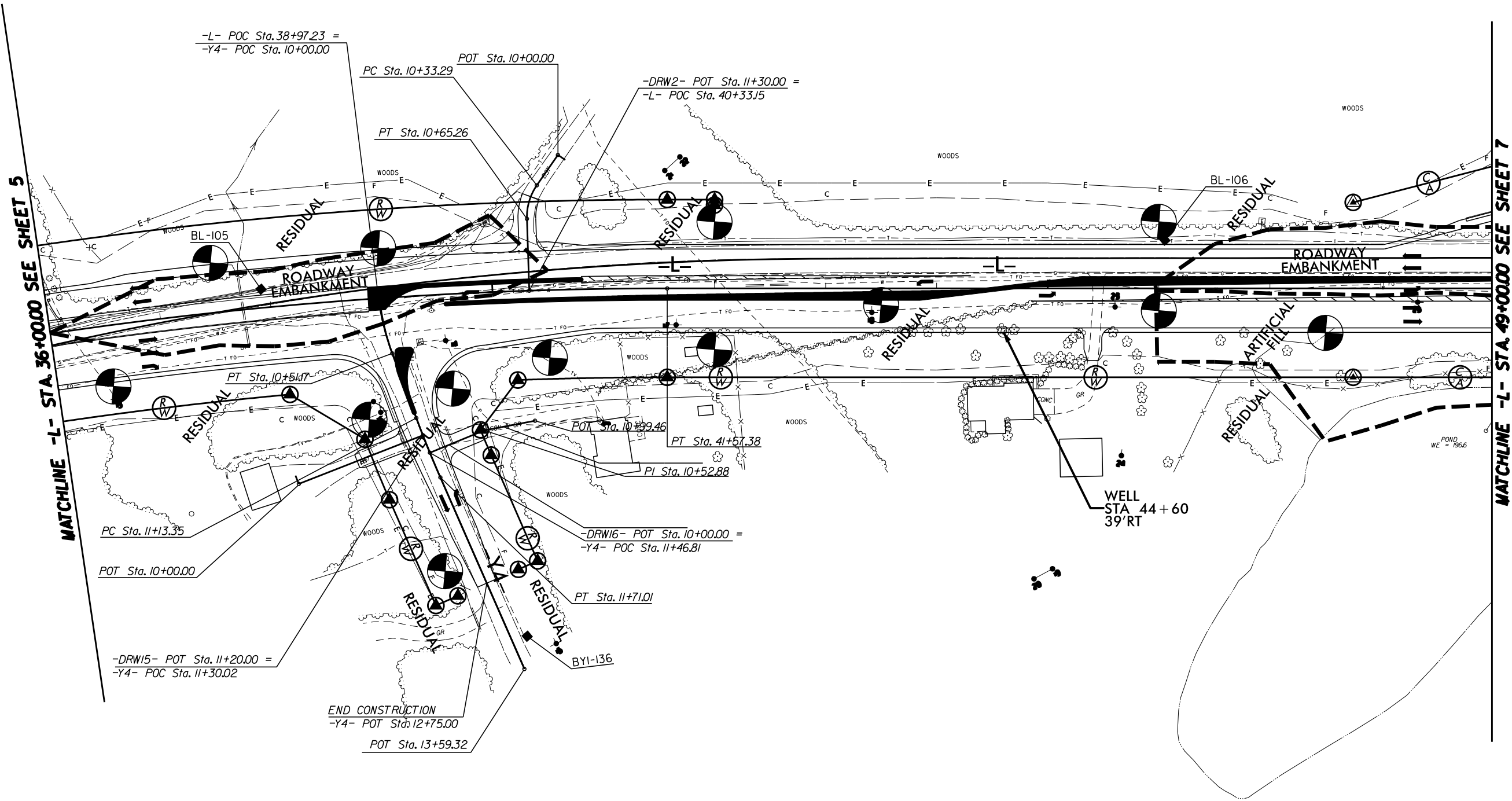

MATCHLINE -L- STA. 36+00.00 SEE SHEET 5

MATCHLINE -L- STA. 49+00.00 SEE SHEET 7

REVISIONS

8/17/09  
C:\CADD\GEO\TECH\Plan\Prj\3825B\Prj\3825B.dwg  
8/17/09  
C:\CADD\GEO\TECH\Plan\Prj\3825B\Prj\3825B.dwg  
8/17/09  
C:\CADD\GEO\TECH\Plan\Prj\3825B\Prj\3825B.dwg

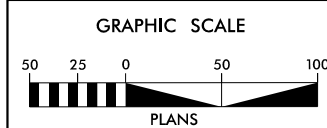

PROJECT REFERENCE NO. <b>R-3825B</b>	SHEET NO. <b>7</b>
RW SHEET NO.	
ROADWAY DESIGN ENGINEER	HYDRAULICS ENGINEER
<b>INCOMPLETE PLANS</b> DO NOT USE FOR R/W ACQUISITION	
<b>DOCUMENT NOT CONSIDERED FINAL</b> UNLESS ALL SIGNATURES COMPLETED	



50+00

55+00

60+00

MATCHLINE -L- STA. 49+00.00 SEE SHEET 6

MATCHLINE -L- STA. 62+00.00 SEE SHEET 8

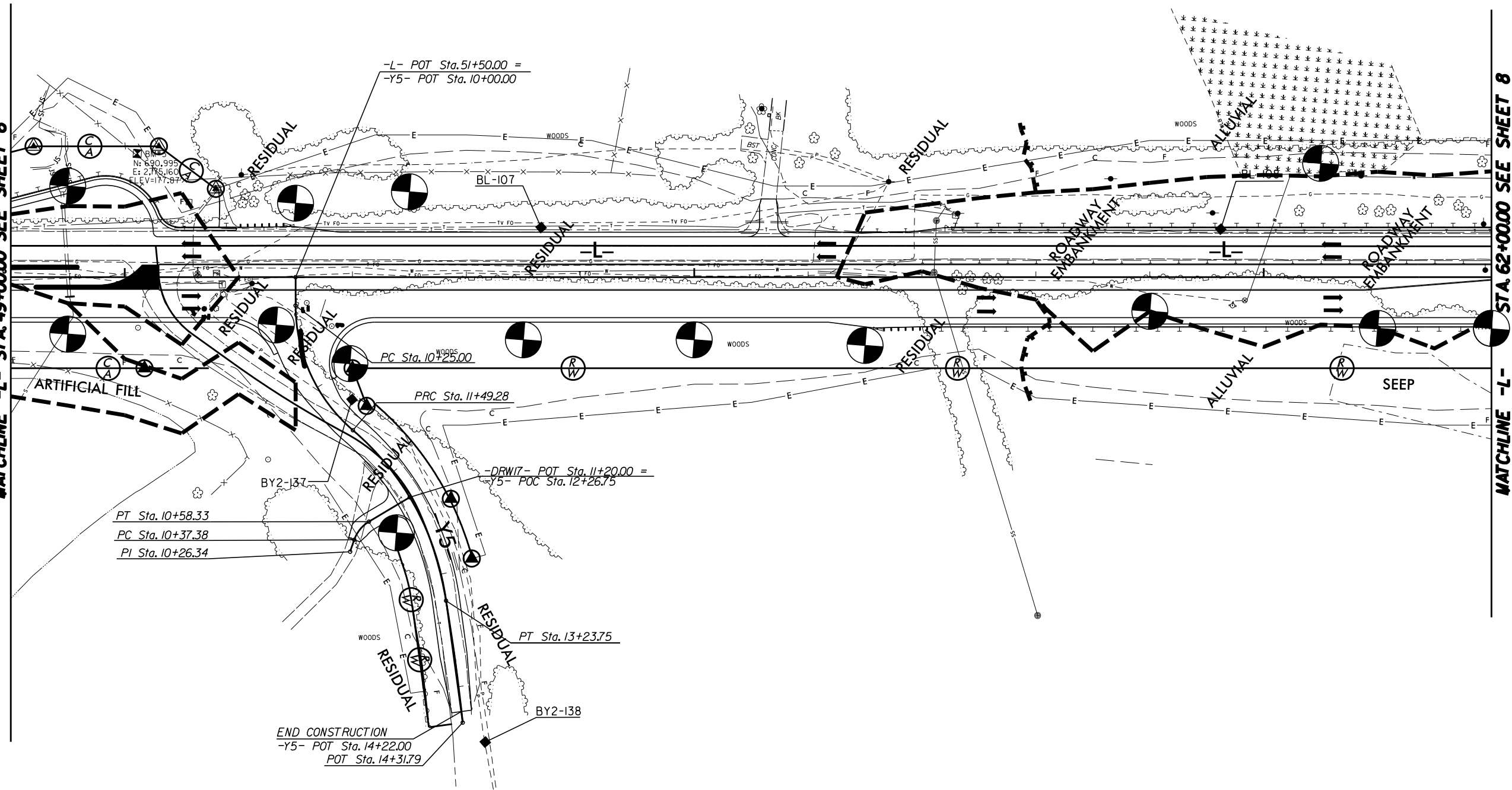

REVISIONS

8/17/09  
C:\CADD\GEO\TECH\Plan\Pr-o\13825b.in\rv.007.dgn  
8/17/09  
C:\CADD\GEO\TECH\Plan\Pr-o\13825b.in\rv.007.dgn

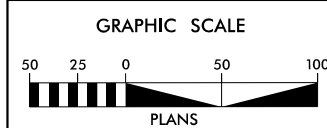

8/17/09

8/17/09 10:07 AM C:\PROJECTS\RDWY\modif\er\CADD\GEO\TECH\Plan\Prj\3825b.in\008.dgn

PROJECT REFERENCE NO. <b>R-3825B</b>	SHEET NO. <b>8</b>
RW SHEET NO.	
ROADWAY DESIGN ENGINEER	HYDRAULICS ENGINEER
<b>INCOMPLETE PLANS</b> DO NOT USE FOR R/W ACQUISITION	
<b>DOCUMENT NOT CONSIDERED FINAL</b> UNLESS ALL SIGNATURES COMPLETED	

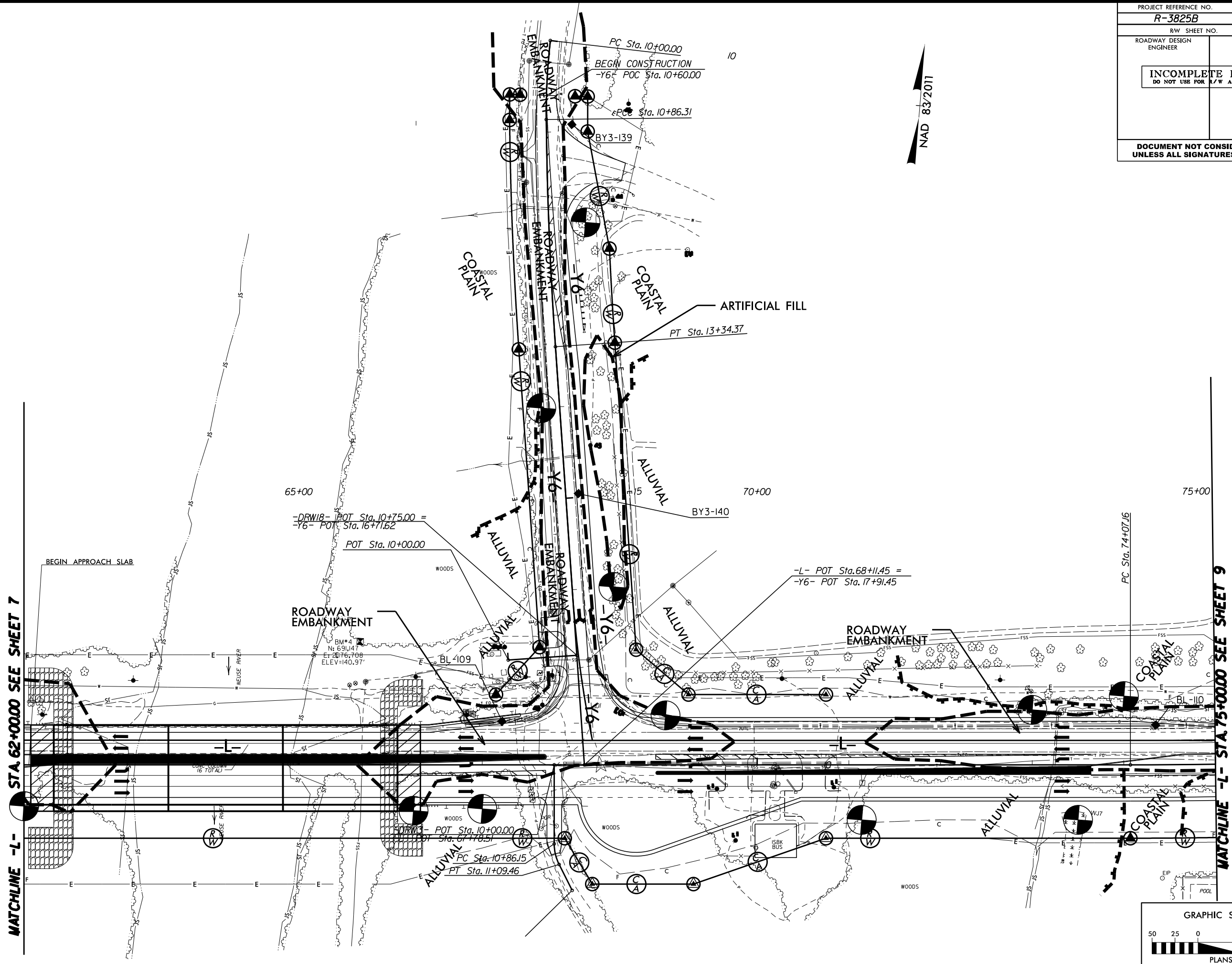

MATCHLINE -L- STA 62+00.00 SEE SHEET 7

MATCHLINE -L- STA 75+00.00 SEE SHEET 9

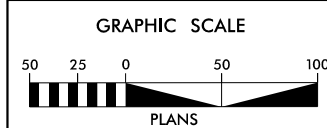

PROJECT REFERENCE NO. <b>R-3825B</b>	SHEET NO. <b>9</b>
RW SHEET NO.	
ROADWAY DESIGN ENGINEER	HYDRAULICS ENGINEER
<b>INCOMPLETE PLANS</b> DO NOT USE FOR R/W ACQUISITION	
<b>DOCUMENT NOT CONSIDERED FINAL</b> UNLESS ALL SIGNATURES COMPLETED	

NAD 83/2011

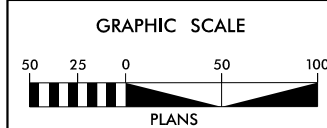
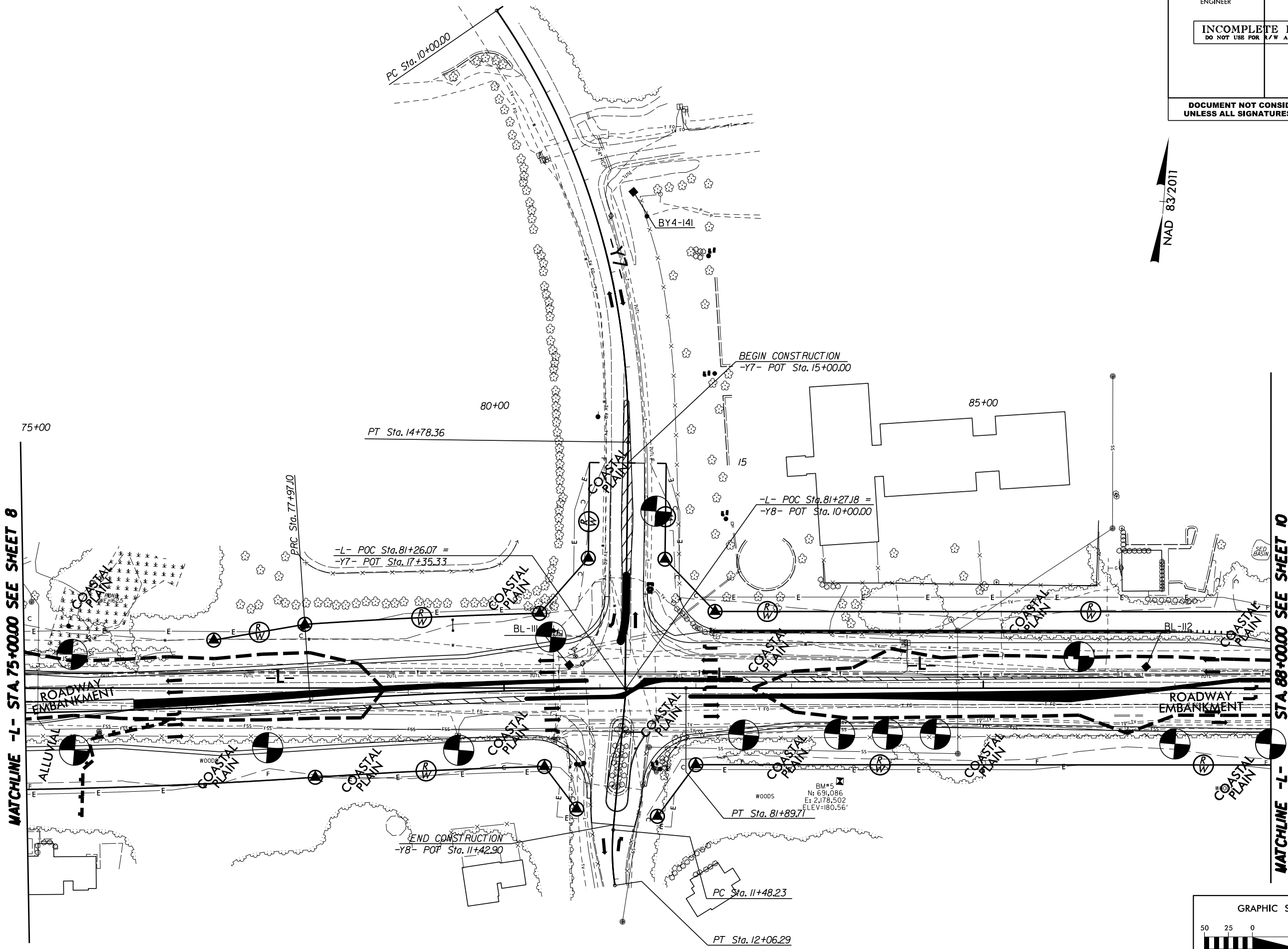

REVISIONS

8/17/09  
 243370017  
 C:\CADD\GEO\RDWY\_medi\file\CADD\_GEO\TECH\Plan\Prj\of\R3825b\_inv\_009.dgn





PROJECT REFERENCE NO. <b>R-3825B</b>	SHEET NO. <b>11</b>
RW SHEET NO.	
ROADWAY DESIGN ENGINEER	HYDRAULICS ENGINEER
<b>INCOMPLETE PLANS</b> DO NOT USE FOR R/W ACQUISITION	
<b>DOCUMENT NOT CONSIDERED FINAL</b> UNLESS ALL SIGNATURES COMPLETED	

NAD 83/2011

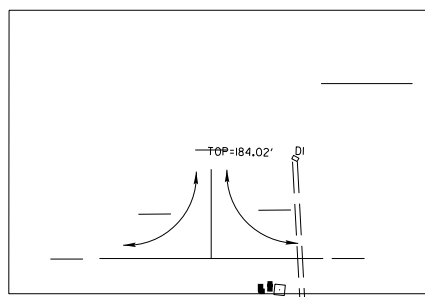
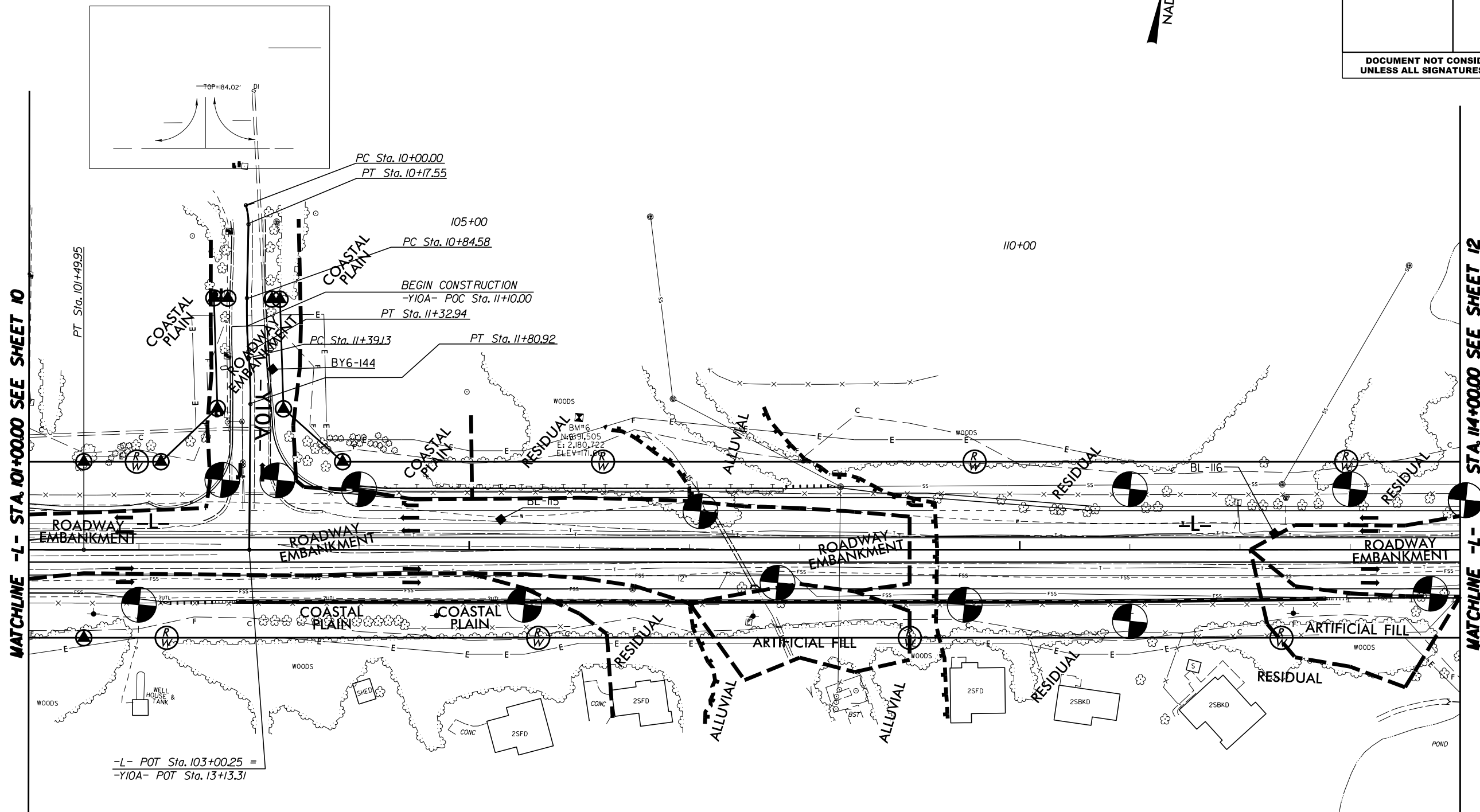

MATCHLINE -L- STA. 101+00.00 SEE SHEET 10

MATCHLINE -L- STA. 114+00.00 SEE SHEET 12

-L- POT Sta. 103+00.25 =  
-Y10A- POT Sta. 13+13.31

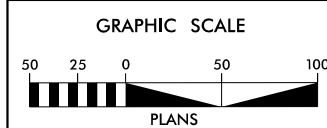

REVISIONS

8/17/09  
\\CADD.GEOTECH\Plan\Prj\R3825B.in\011.dgn  
\\CADD.GEOTECH\Plan\Prj\R3825B.in\011.dgn  
\\CADD.GEOTECH\Plan\Prj\R3825B.in\011.dgn



PROJECT REFERENCE NO. <b>R-3825B</b>	SHEET NO. <b>13</b>
R/W SHEET NO.	
ROADWAY DESIGN ENGINEER	HYDRAULICS ENGINEER
<b>INCOMPLETE PLANS</b> DO NOT USE FOR R/W ACQUISITION	
<b>DOCUMENT NOT CONSIDERED FINAL</b> UNLESS ALL SIGNATURES COMPLETED	

-Y10C- BROOKHAVEN DR

PI Sta 12+68.33  
 $\Delta = 25' 15" 36.6" (RT)$   
 $D = 10' 54" 48.5"$   
 $L = 231.46'$   
 $T = 117.64'$   
 $R = 525.00'$



BEGIN CONSTRUCTION  
 -Y10C- POC Sta. 12+05.00

MATCHLINE -L- STA 127+00.00 SEE SHEET 12

MATCHLINE -L- STA 140+00.00 SEE SHEET 14

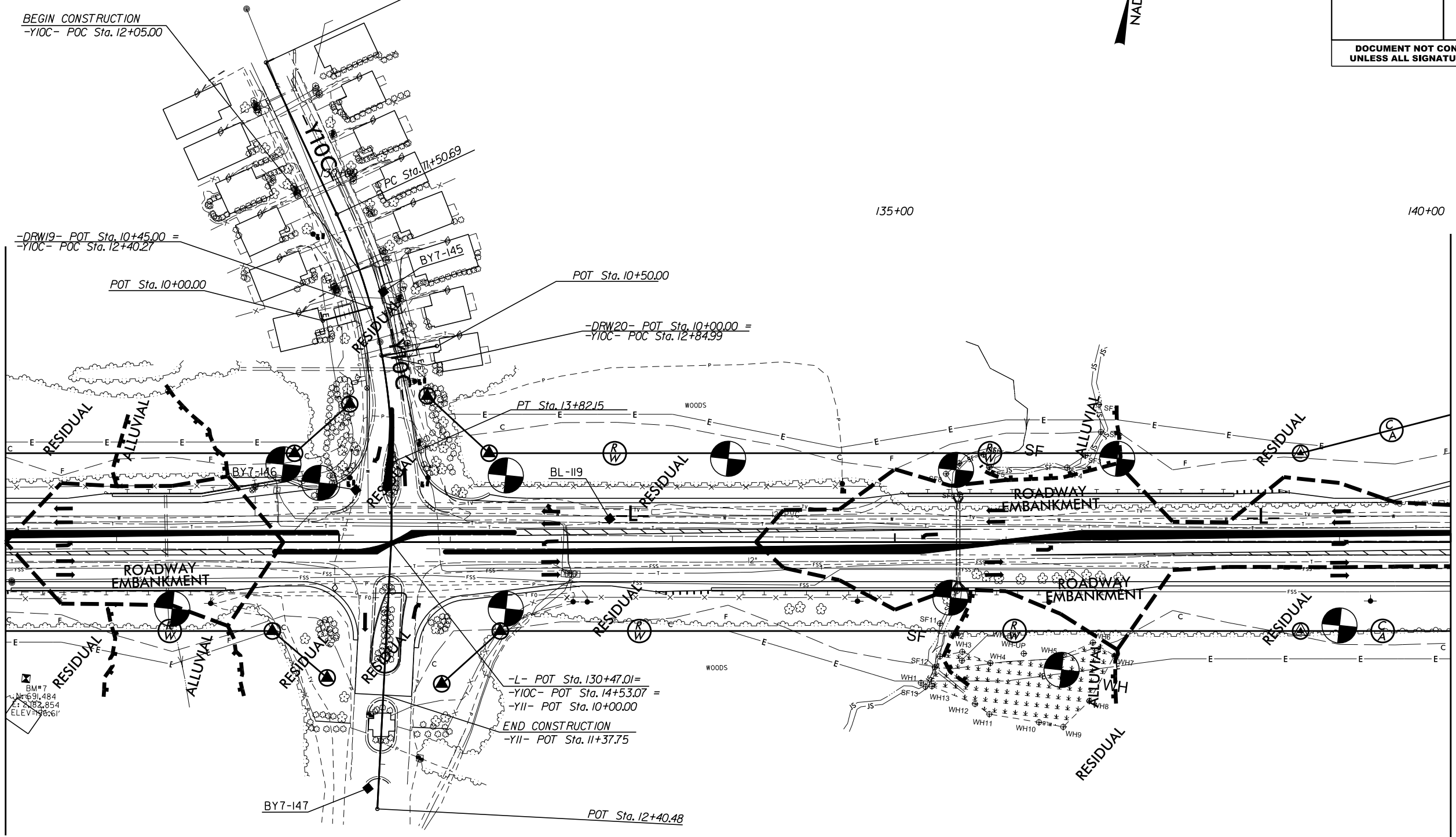

REVISIONS

2/23/2011 8:17:99  
 2:\K\K\001\1R-3825B\1R-3825B.GED\_PDWY\_mod\1R-3825B.dgn  
 2:\K\K\001\1R-3825B\1R-3825B.GED\_PDWY\_mod\1R-3825B.dgn

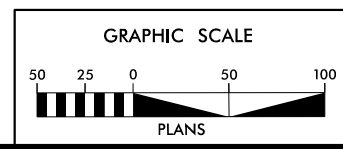







PROJECT REFERENCE NO. <b>R-3825B</b>	SHEET NO. <b>16</b>
RW SHEET NO.	
ROADWAY DESIGN ENGINEER	HYDRAULICS ENGINEER
<b>INCOMPLETE PLANS</b> DO NOT USE FOR R/W ACQUISITION	
<b>DOCUMENT NOT CONSIDERED FINAL</b> UNLESS ALL SIGNATURES COMPLETED	

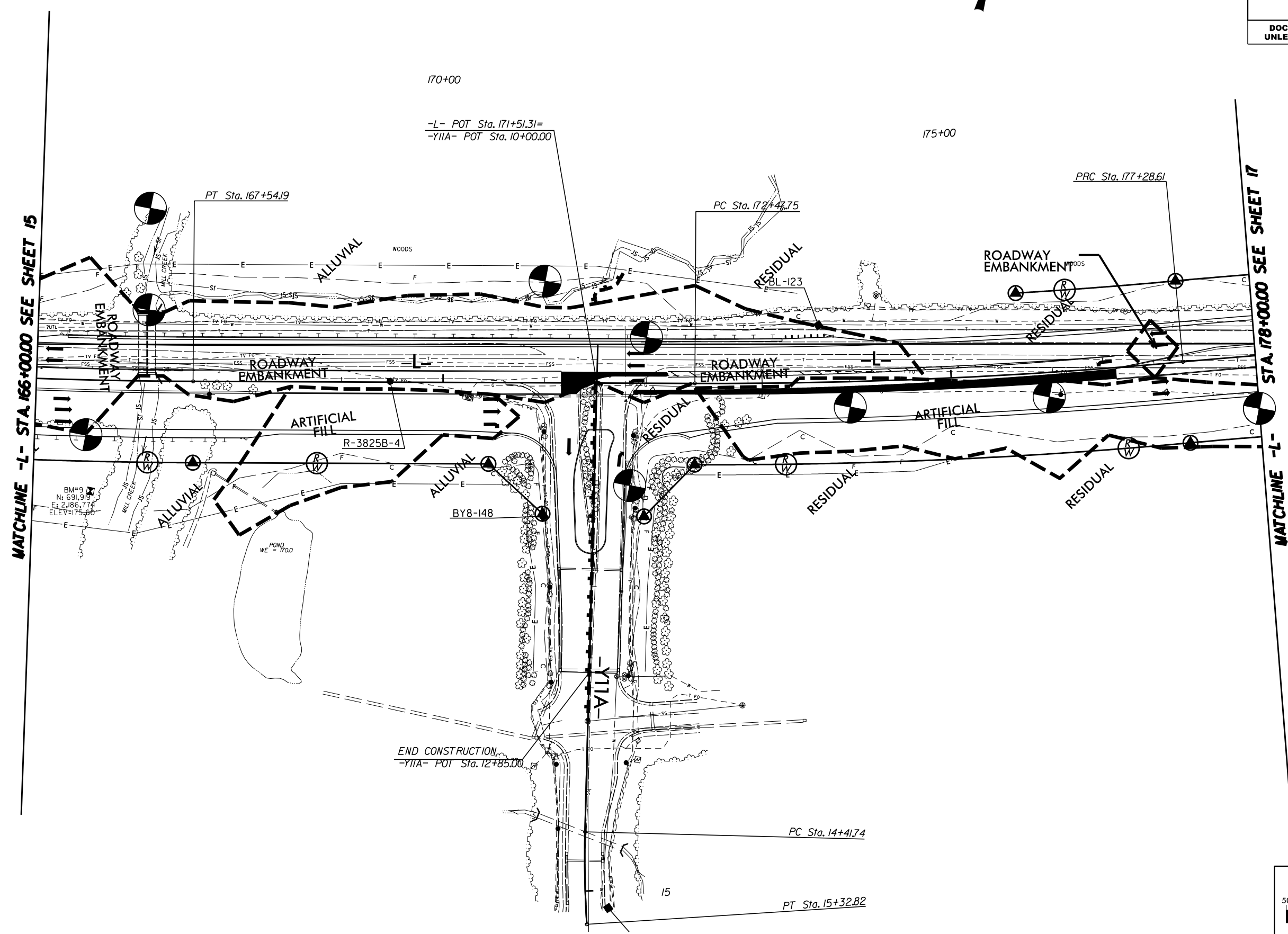

REVISIONS

8/17/09  
 2/23/2007  
 C:\CADD\GEO\TECH\Plan\Prj\3825b.in\016.dgn  
 R-3825B\Pr-3825B\_GEO\_RDWY\_mod1.rvt

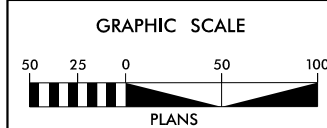



PROJECT REFERENCE NO. <b>R-3825B</b>	SHEET NO. <b>18</b>
R/W SHEET NO. ROADWAY DESIGN ENGINEER	HYDRAULICS ENGINEER
<b>INCOMPLETE PLANS</b> DO NOT USE FOR R/W ACQUISITION	
<b>DOCUMENT NOT CONSIDERED FINAL</b> UNLESS ALL SIGNATURES COMPLETED	

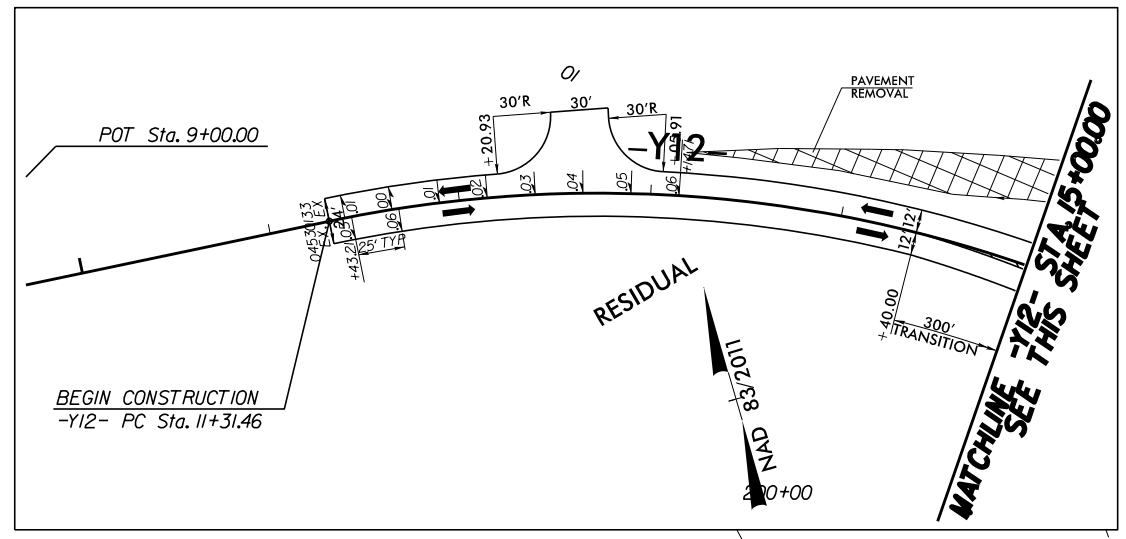
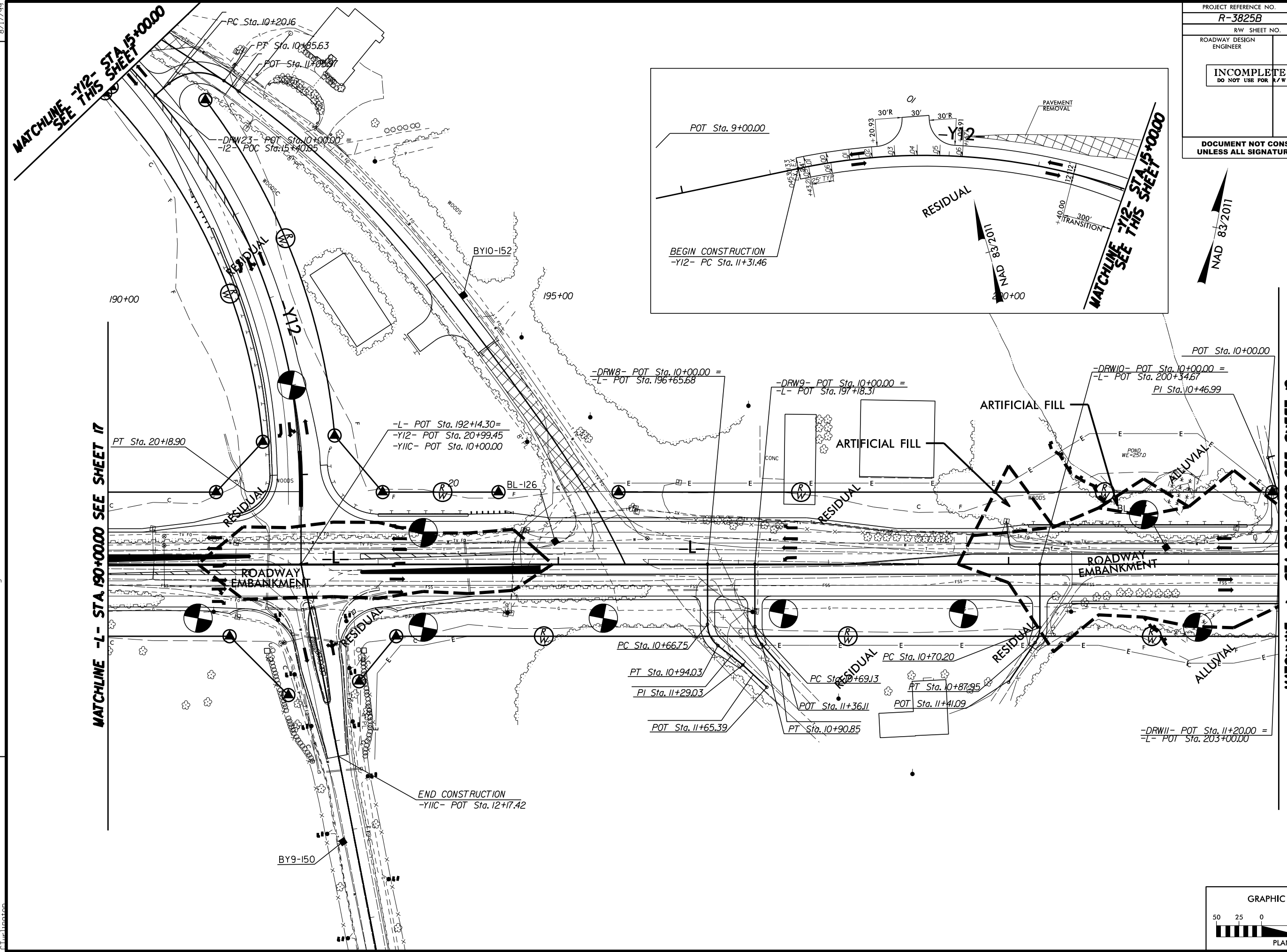

**MATCHLINE -Y12- STA.15+00.00**  
SEE THIS SHEET

**MATCHLINE -Y12- STA.15+00.00**  
SEE THIS SHEET

**MATCHLINE -L- STA.190+00.00 SEE SHEET 17**

**MATCHLINE -L- STA.203+00.00 SEE SHEET 19**

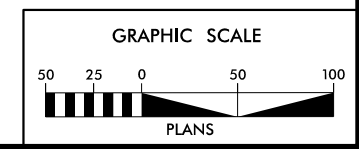

REVISIONS

8/17/09  
C:\CADD\GEO\TECH\Plan\Pr\of\R3825B.in\018.dgn  
2/23/2017 10:00 AM  
C:\CADD\GEO\RDWY\modif\1e\3825B\Pr-3825B.GEO.RDWY





PROJECT REFERENCE NO. <b>R-3825B</b>	SHEET NO. <b>20</b>
RW SHEET NO.	
ROADWAY DESIGN ENGINEER	HYDRAULICS ENGINEER
<b>INCOMPLETE PLANS</b> DO NOT USE FOR R/W ACQUISITION	
<b>DOCUMENT NOT CONSIDERED FINAL</b> UNLESS ALL SIGNATURES COMPLETED	



**MATCHLINE -L- STA. 26+00.00 SEE SHEET 19**

**MATCHLINE -L- STA. 229+00.00 SEE SHEET 21**

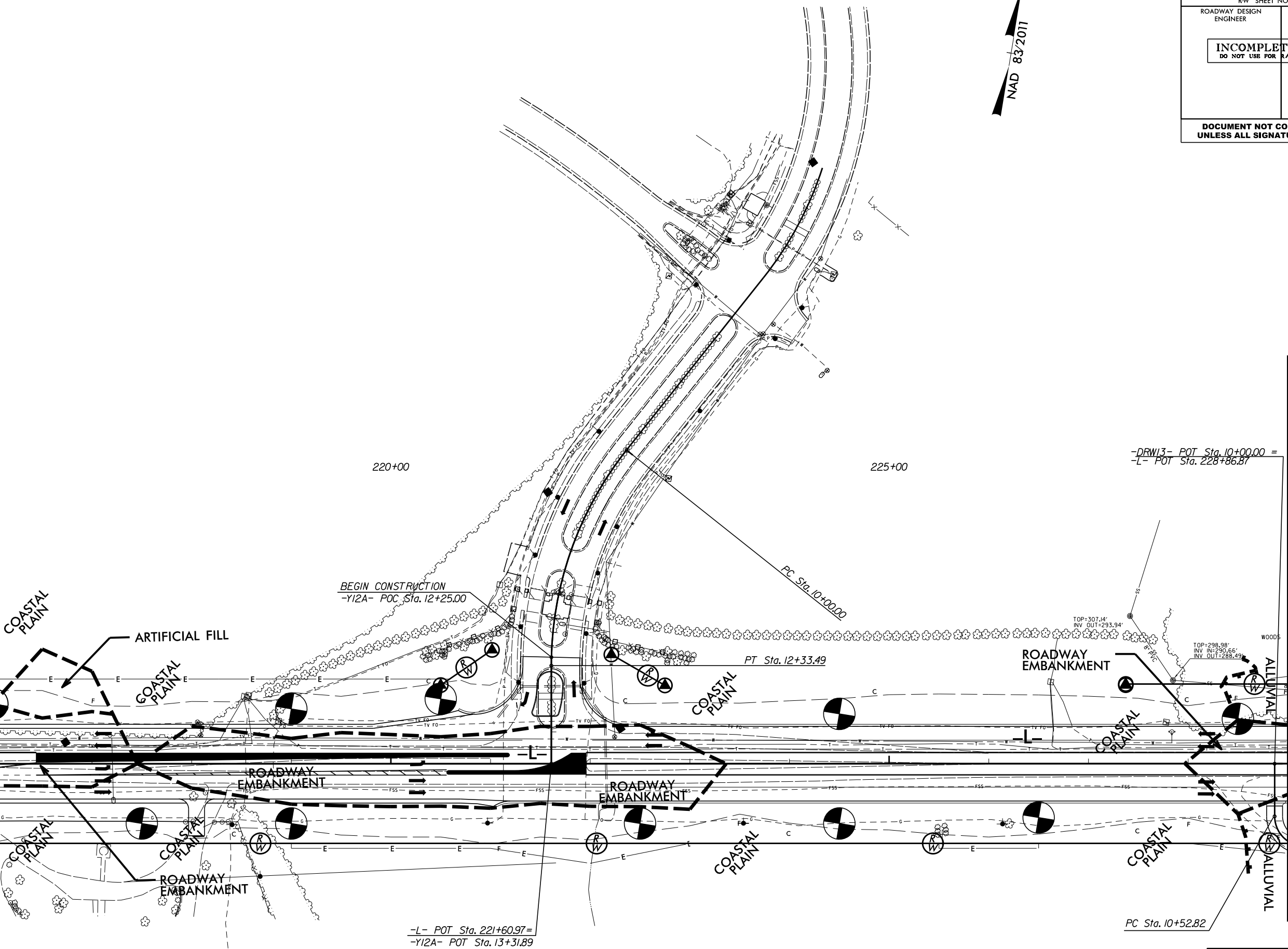

-DRW13- POT Sta. 10+00.00 =  
-L- POT Sta. 228+86.87

BEGIN CONSTRUCTION  
-Y12A- POC Sta. 12+25.00

PT Sta. 12+33.49

TOP=307.14'  
INV. OUT=293.94'

TOP=296.98'  
INV. IN=290.65'  
INV. OUT=288.49'

-L- POT Sta. 221+60.97=  
-Y12A- POT Sta. 13+31.89

PC Sta. 10+52.82

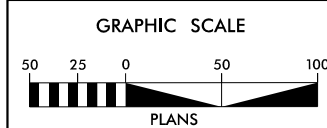

REVISIONS

8/17/09  
8/31/2011  
C:\projects\3825B\3825B.GEO\_RDWY\_modif.dgn  
C:\projects\3825B\3825B.GEO\_RDWY\_modif.dgn  
C:\projects\3825B\3825B.GEO\_RDWY\_modif.dgn



PROJECT REFERENCE NO. <b>R-3825B</b>	SHEET NO. <b>22</b>
RW SHEET NO.	
ROADWAY DESIGN ENGINEER	HYDRAULICS ENGINEER
<b>INCOMPLETE PLANS</b> DO NOT USE FOR R/W ACQUISITION	
<b>DOCUMENT NOT CONSIDERED FINAL</b> UNLESS ALL SIGNATURES COMPLETED	

8/17/09  
 REVISIONS  
 \CADD\GEO\TECH\Plan\Prj\3825B\inv\_022.dgn  
 \CADD\GEO\TECH\Plan\Prj\3825B\mod1.fie  
 \CADD\GEO\TECH\Plan\Prj\3825B\GEO\RDWY\mod1.fie  
 \CADD\GEO\TECH\Plan\Prj\3825B\GEO\RDWY\mod1.fie

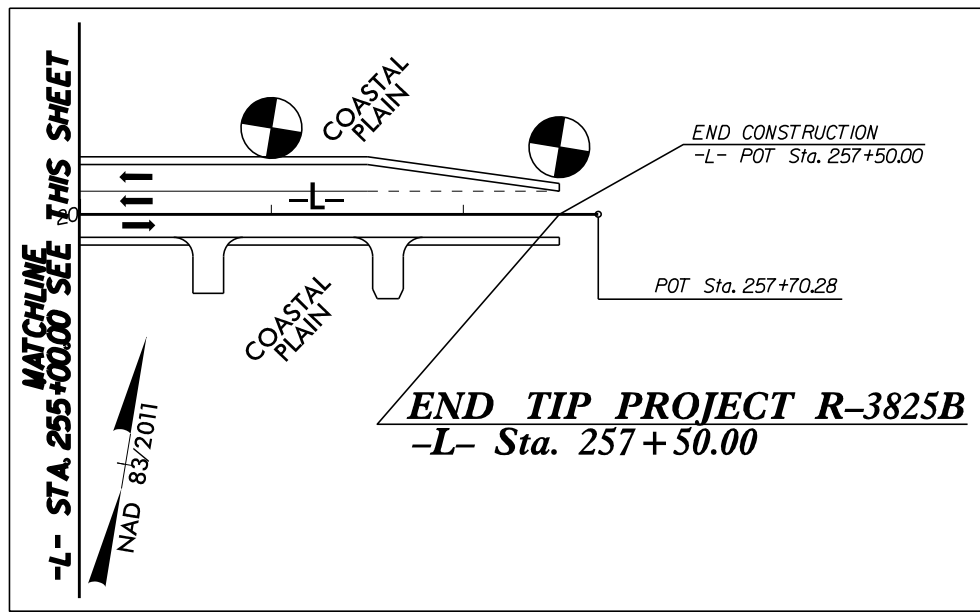
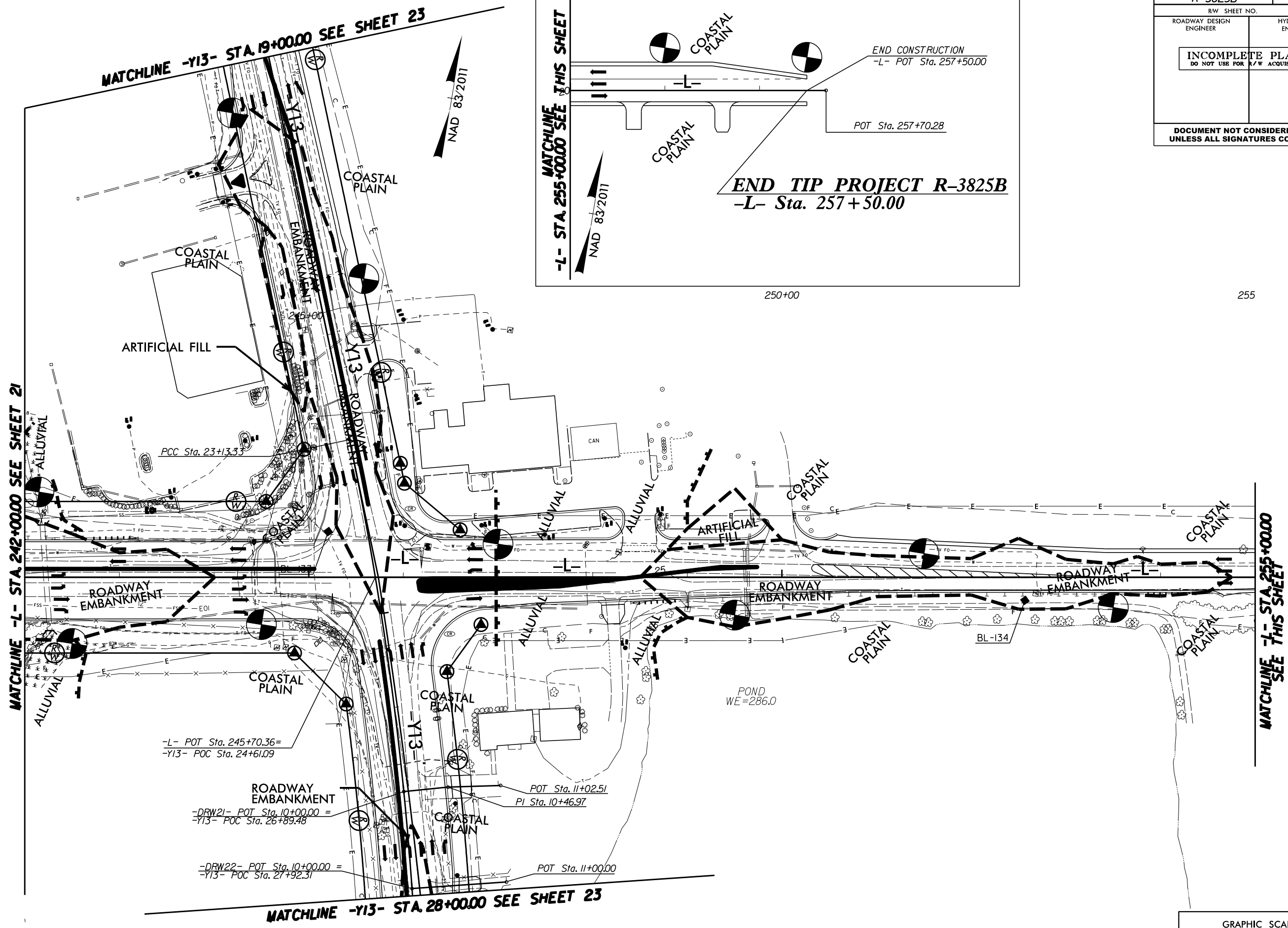

250+00

255

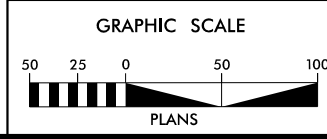



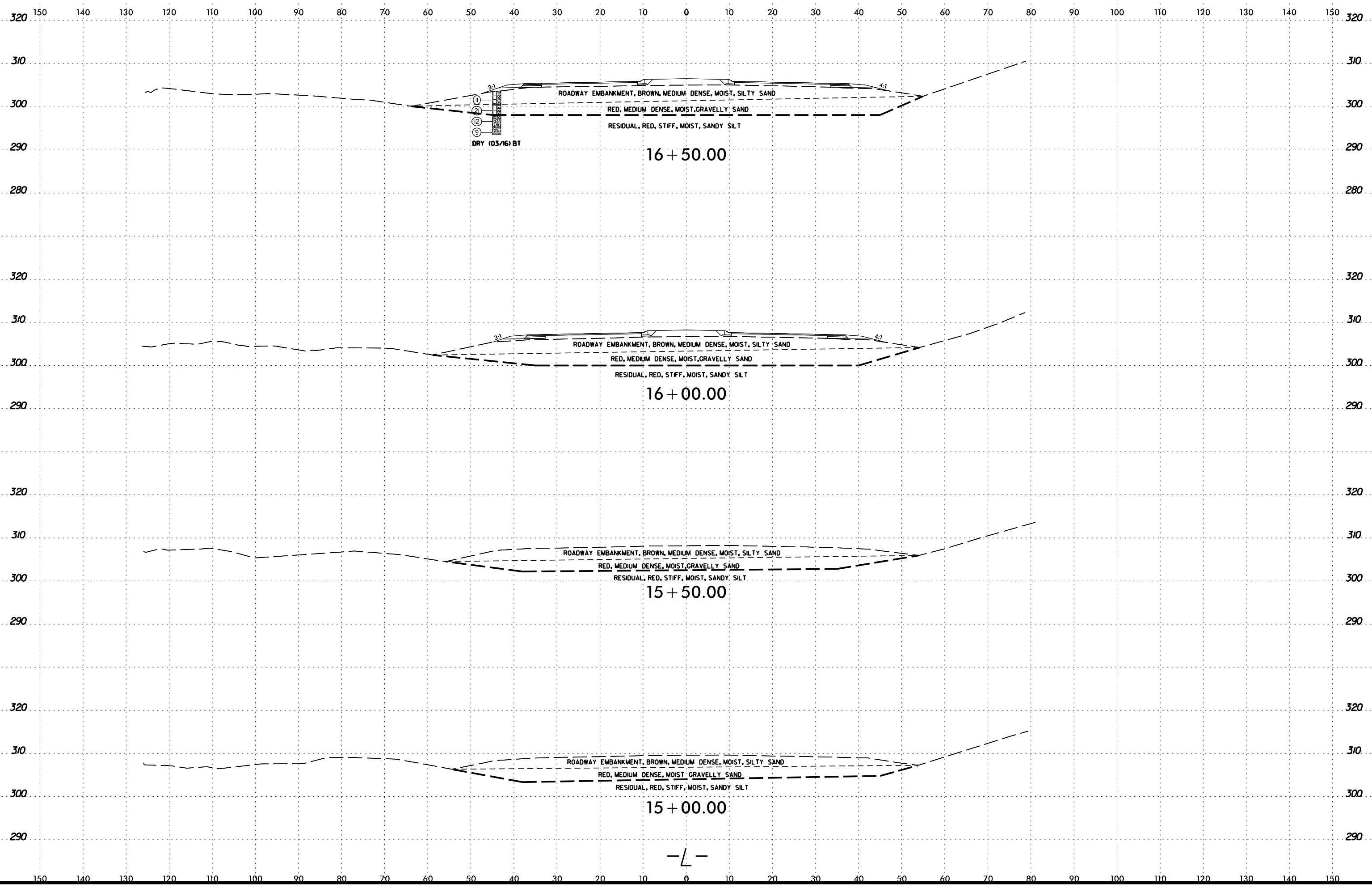

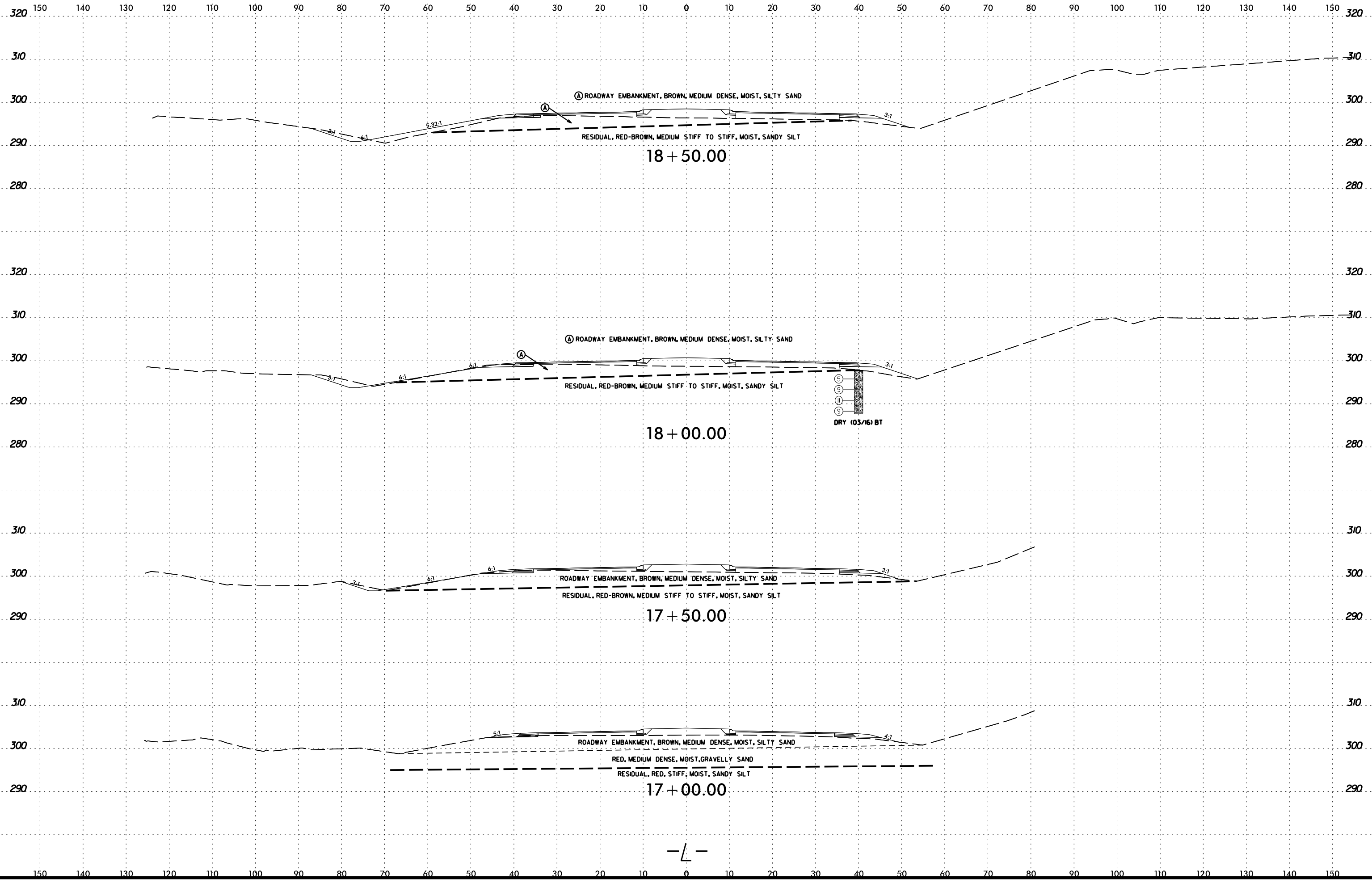







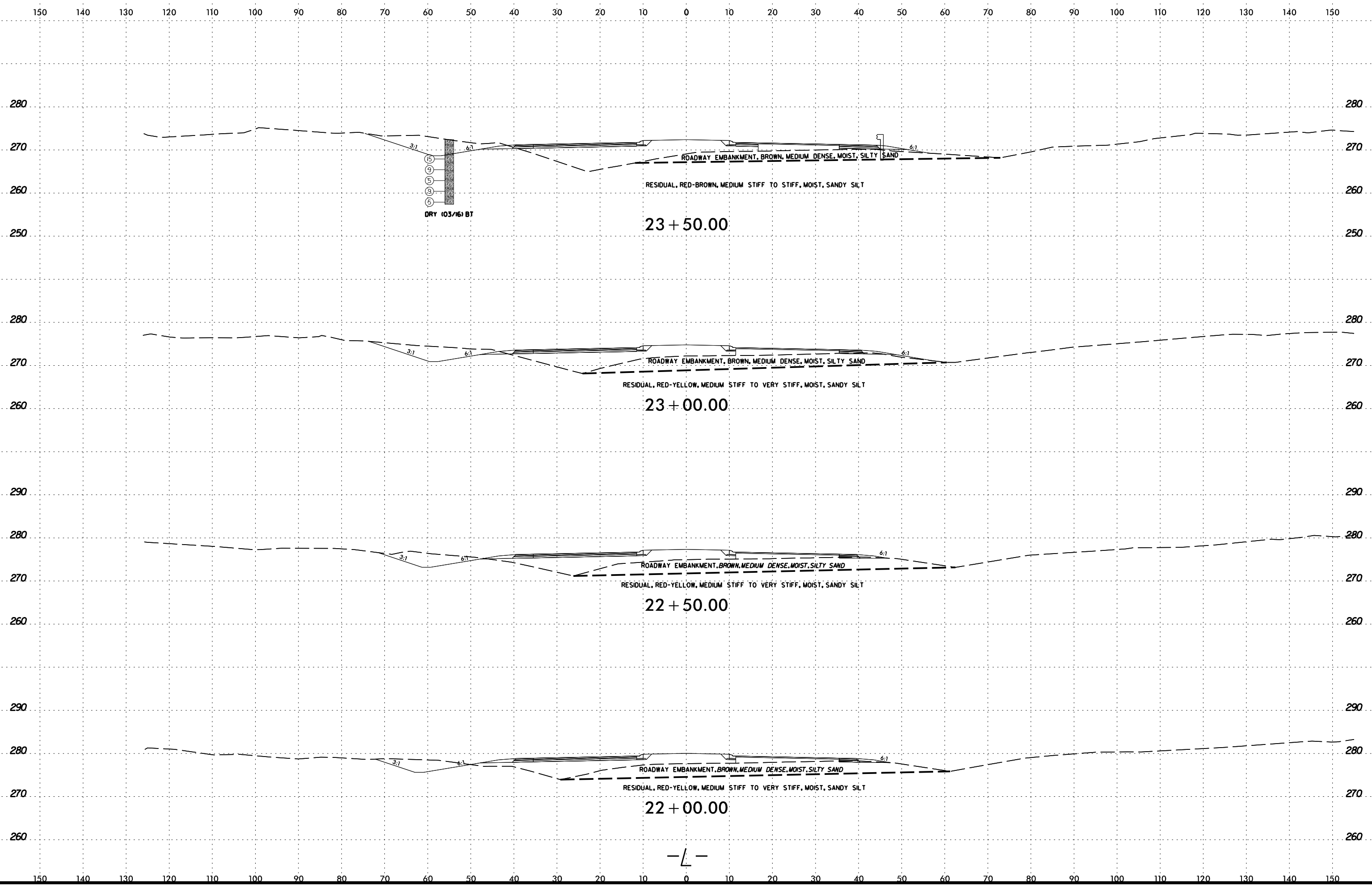

6/23/16

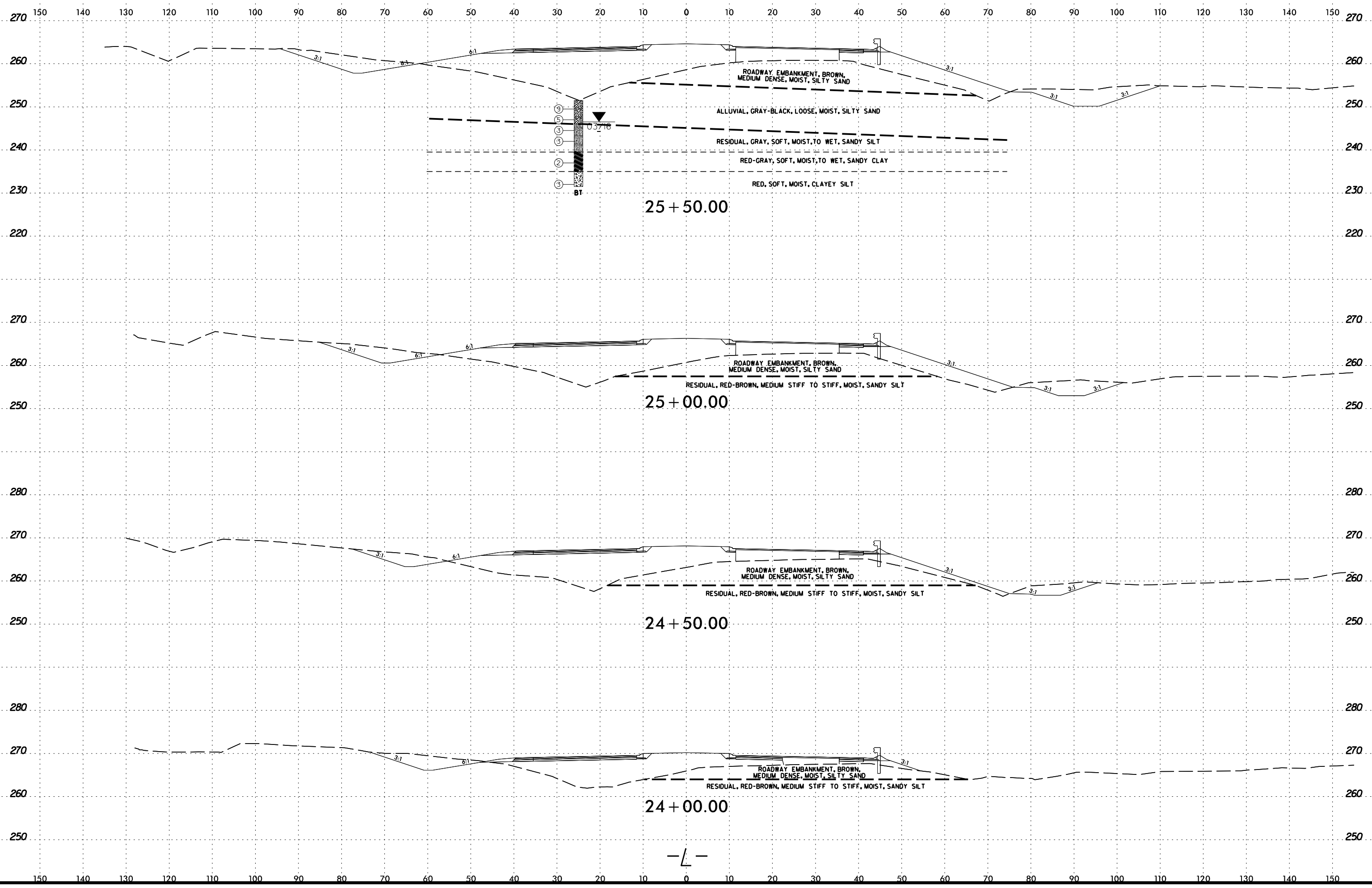

2/23/2017  
M:\N\NCD01\R-3825B\R-3825B.GEO\_RDWY.mxd  
C:\Users\lmgton

6/23/16

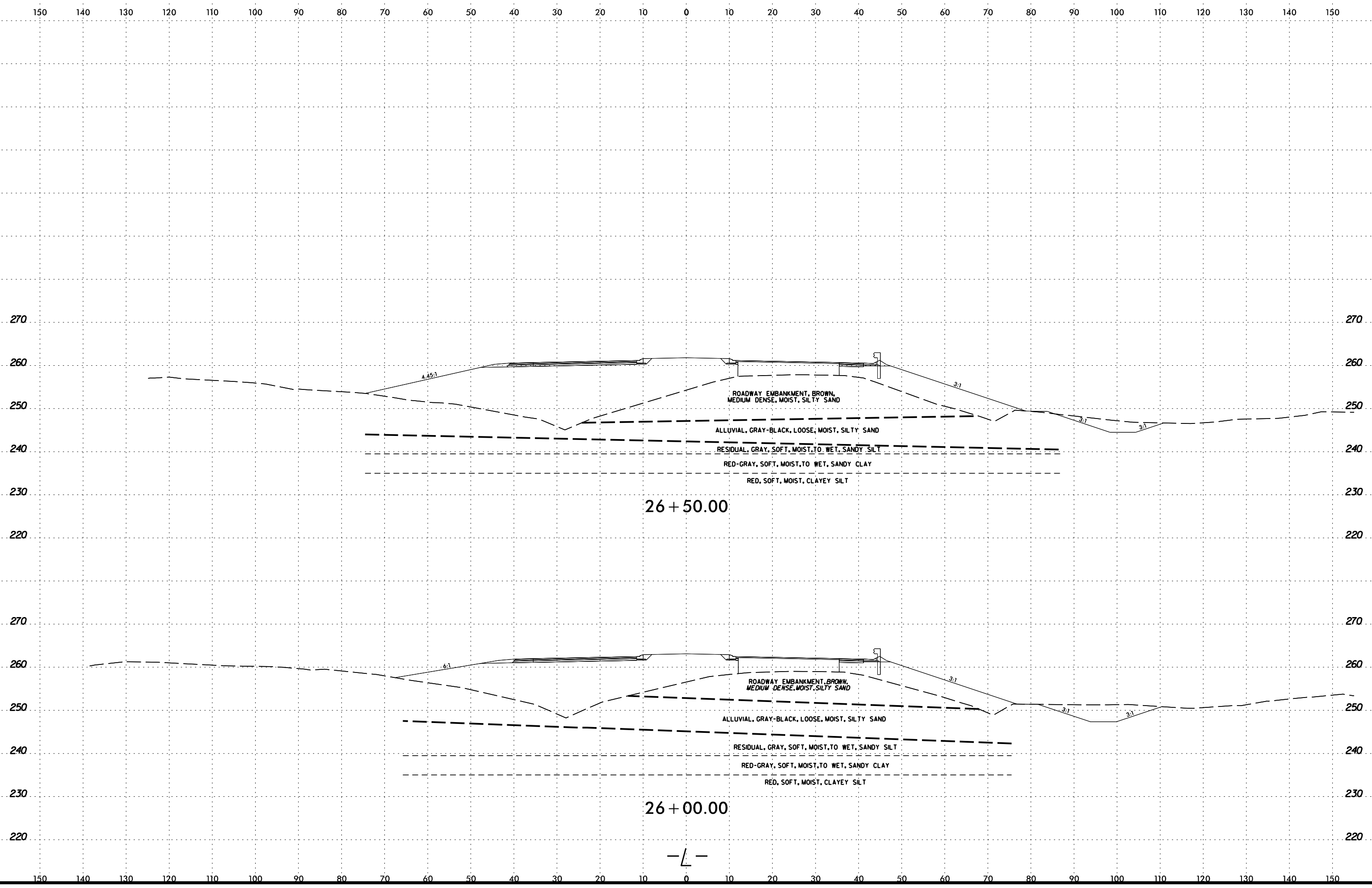

2/23/2017  
M:\N\CD01\R-3825B\R-3825B.GEO\_RDWY.mxd  
C:\ur\imgton

6/23/16  
2/23/2017  
M:\N\NCD01\R-3825B\R-3825B.GEO\_RDWY.mxd  
C:\Users\imington

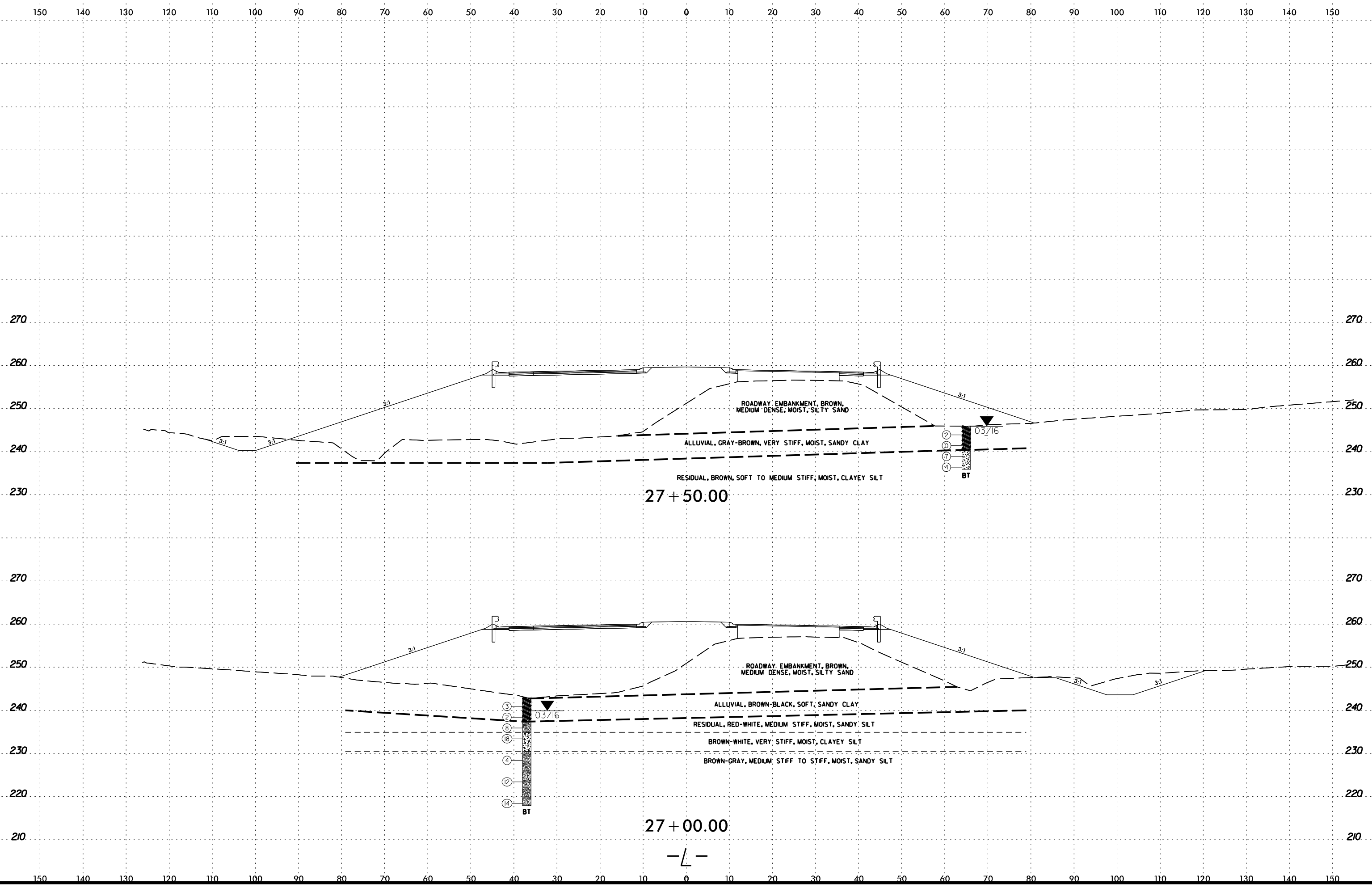

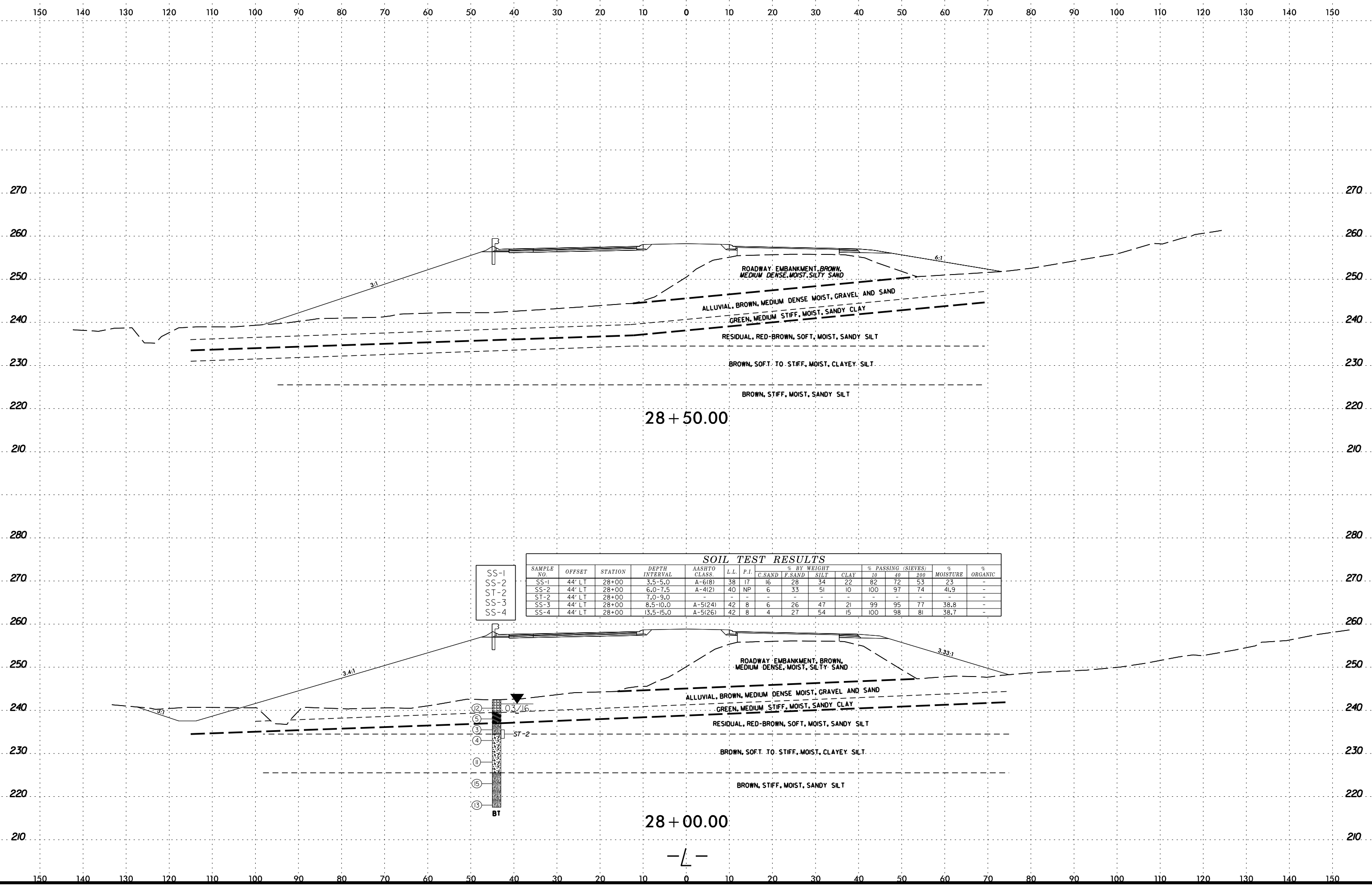

28 + 50.00

28 + 00.00

SOIL TEST RESULTS															
SAMPLE NO.	OFFSET	STATION	DEPTH INTERVAL	AASHTO CLASS.	L.L.	P.I.	% BY WEIGHT				% PASSING (SIEVES)			% MOISTURE	% ORGANIC
							C.SAND	F.SAND	SILT	CLAY	10	40	200		
SS-1	44' LT	28+00	3.5-5.0	A-6(B)	38	17	16	28	34	22	82	72	53	23	-
SS-2	44' LT	28+00	6.0-7.5	A-4(2)	40	NP	6	33	51	10	100	97	74	41.9	-
ST-2	44' LT	28+00	7.0-9.0	-	-	-	-	-	-	-	-	-	-	-	-
SS-3	44' LT	28+00	8.5-10.0	A-5(24)	42	8	6	26	47	21	99	95	77	38.8	-
SS-4	44' LT	28+00	13.5-15.0	A-5(26)	42	8	4	27	54	15	100	98	81	38.7	-

- SS-1
- SS-2
- ST-2
- SS-3
- SS-4

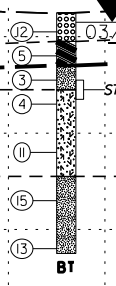

6/23/16

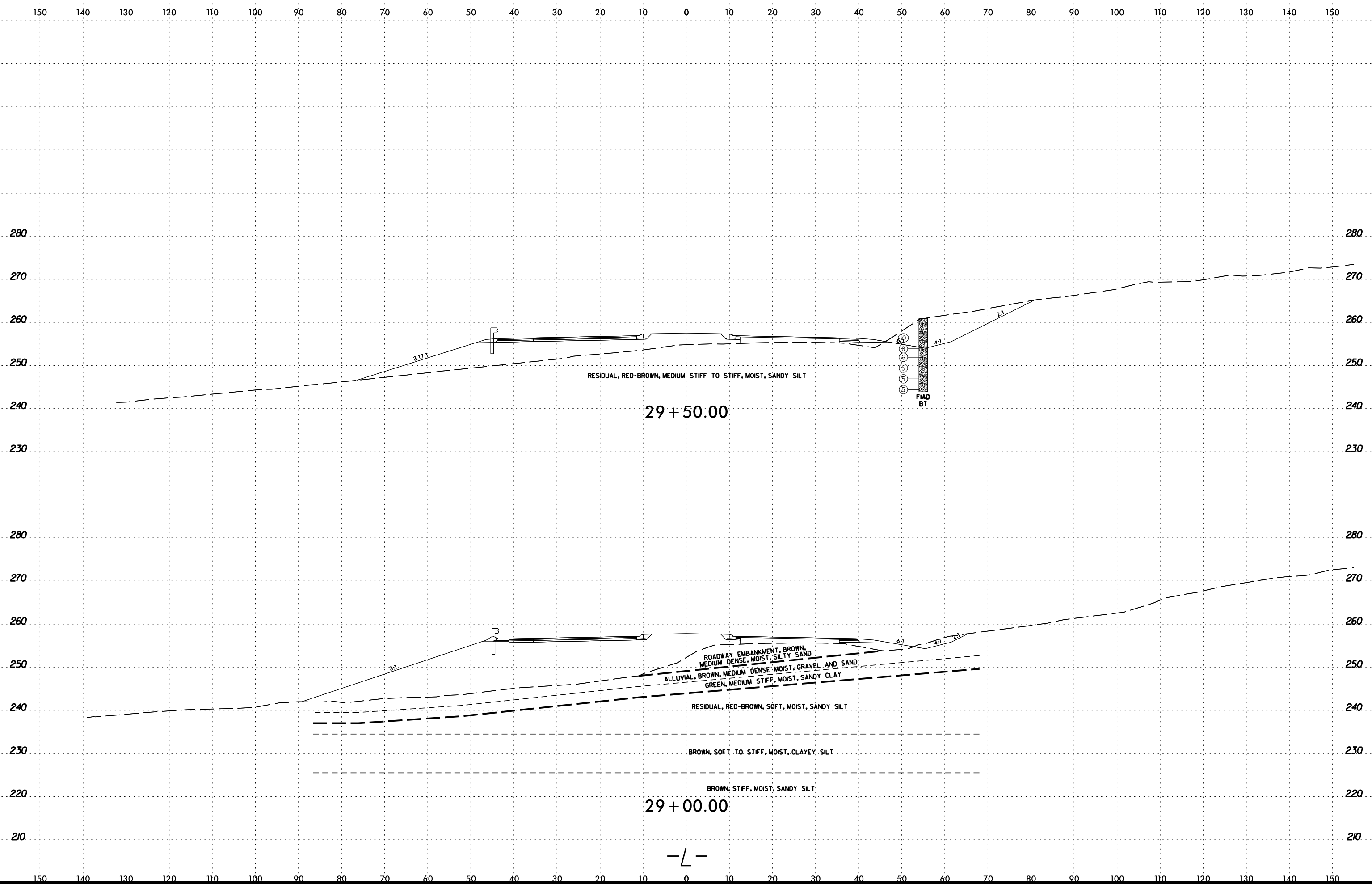

2/23/2017  
C:\Users\mcc01\OneDrive\Documents\29+00\29+00.dgn

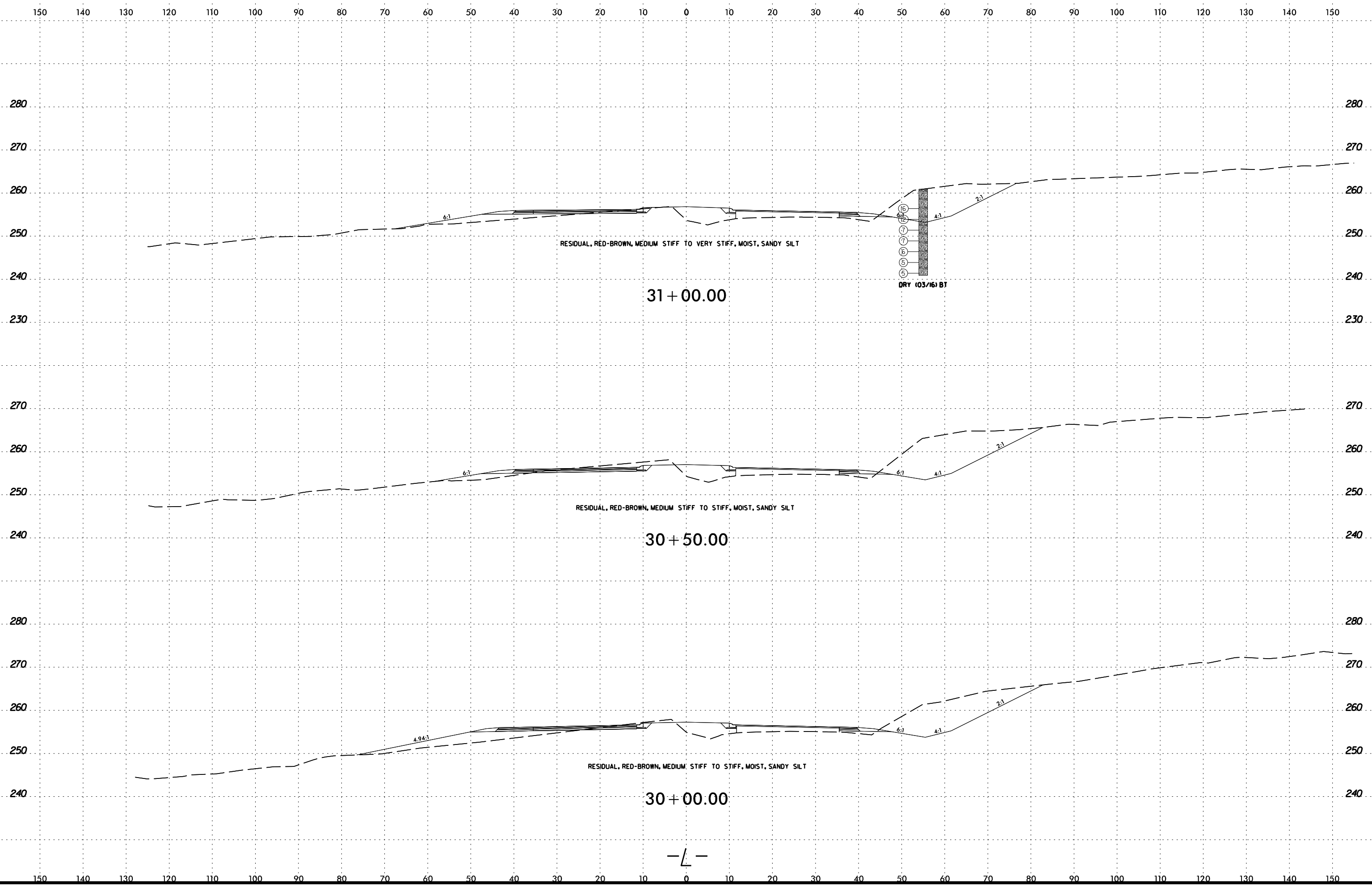

6/23/16

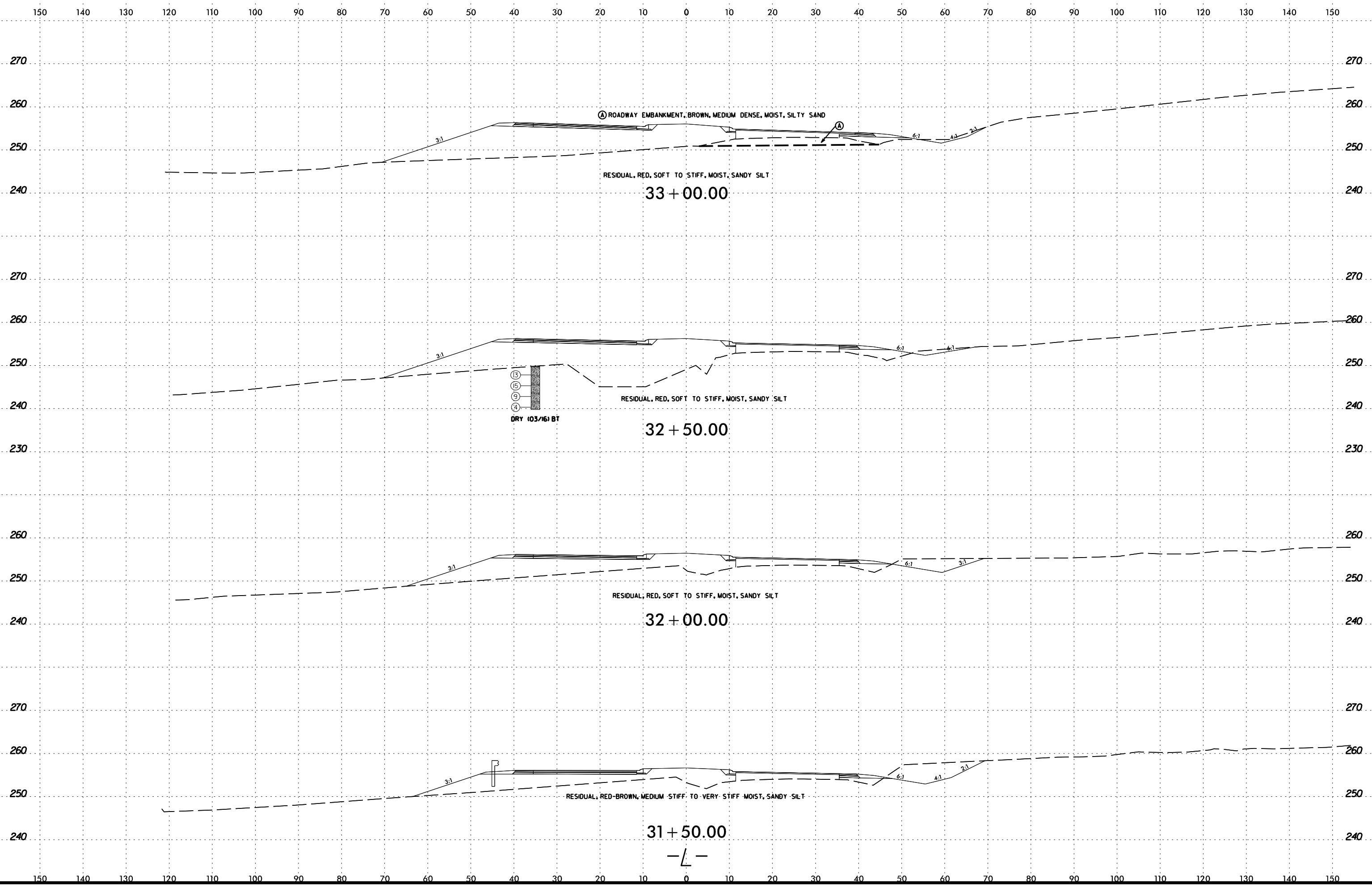

2/23/2017  
M:\N\CD01\R-3825B-R-3825B.GEO..RDWY..modifler\CA00.GEOTECH\sc\R3825B\_Geo\_xsi.1.(15+00-62+50).dgn  
C:\ur\ington



6/23/16

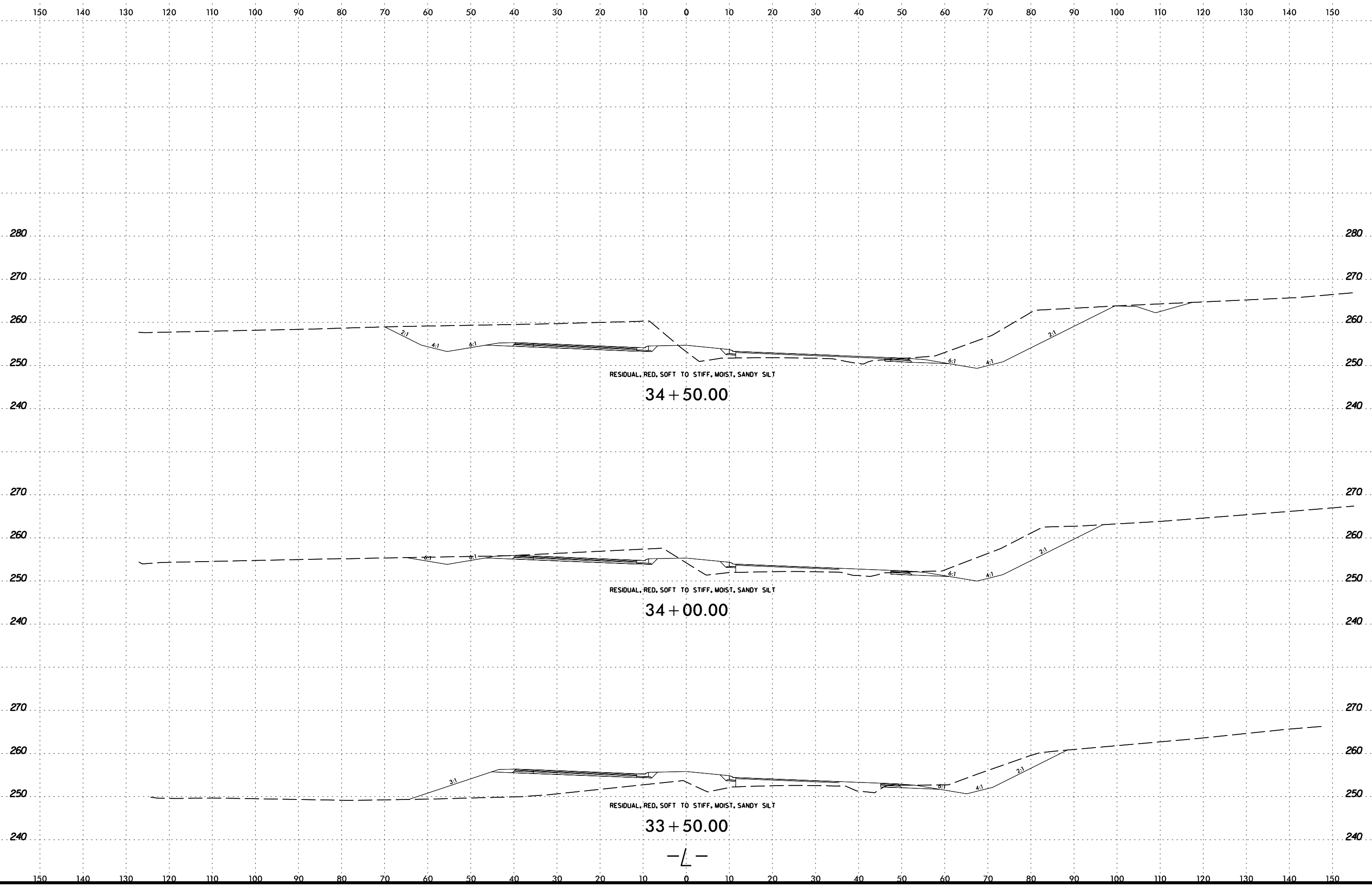

2/23/2017  
M:\N\CD01\R-3825B-R-3825B.GEO.RDWY..modifler\CA00.GEOTECH\sc\R3825B\_Geo\_xsi\_1\_(15+00-62+50).dgn  
C:\ur\imgton





6/23/16

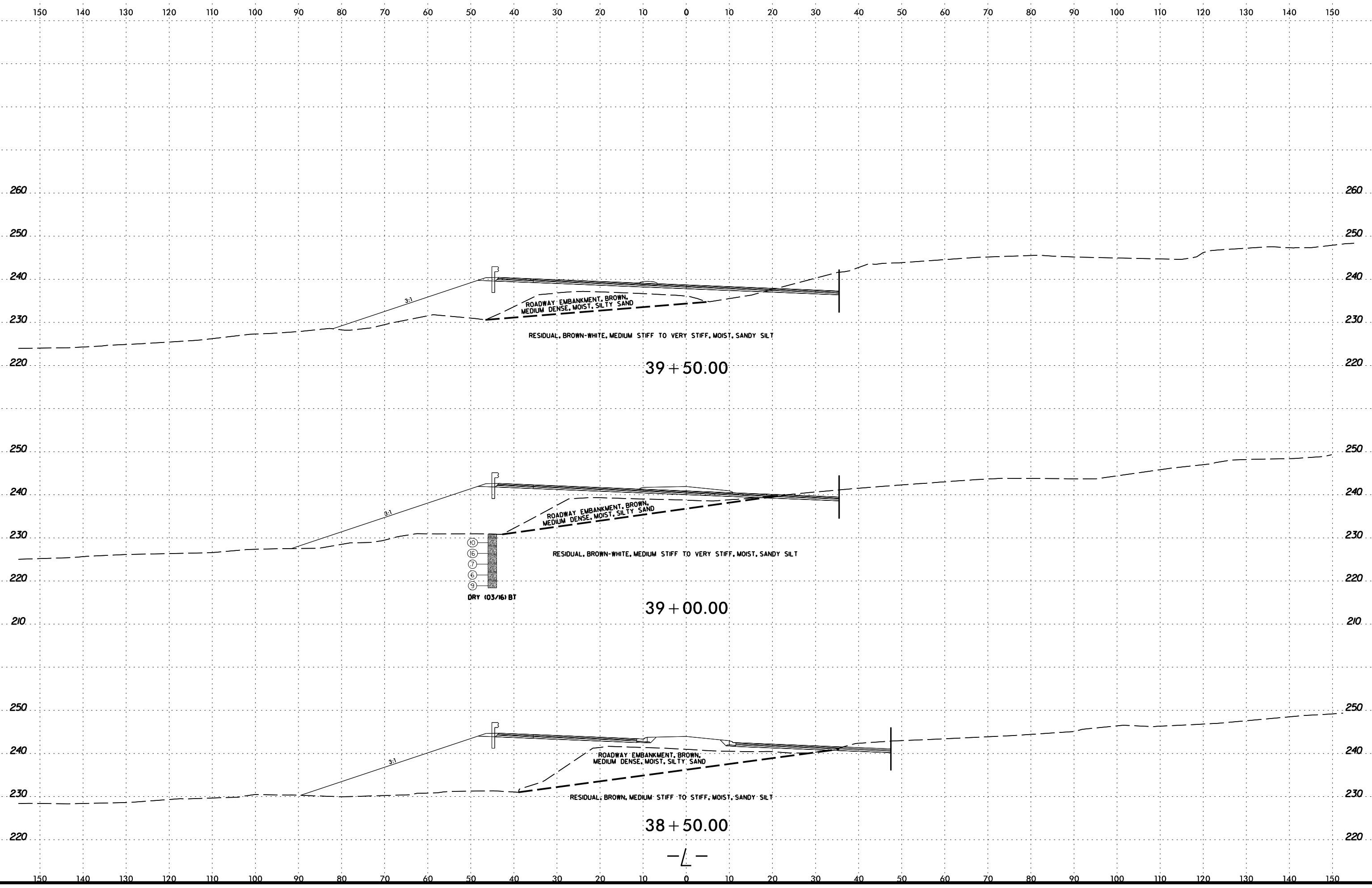

2/23/2017  
 M:\N\CD01\R-3825B-R-3825B.GEO\_RDWY.mxd  
 C:\Program Files\Autodesk\AutoCAD 2010\AutoCAD.exe  
 C:\Program Files\Autodesk\AutoCAD 2010\AutoCAD.exe

6/23/16

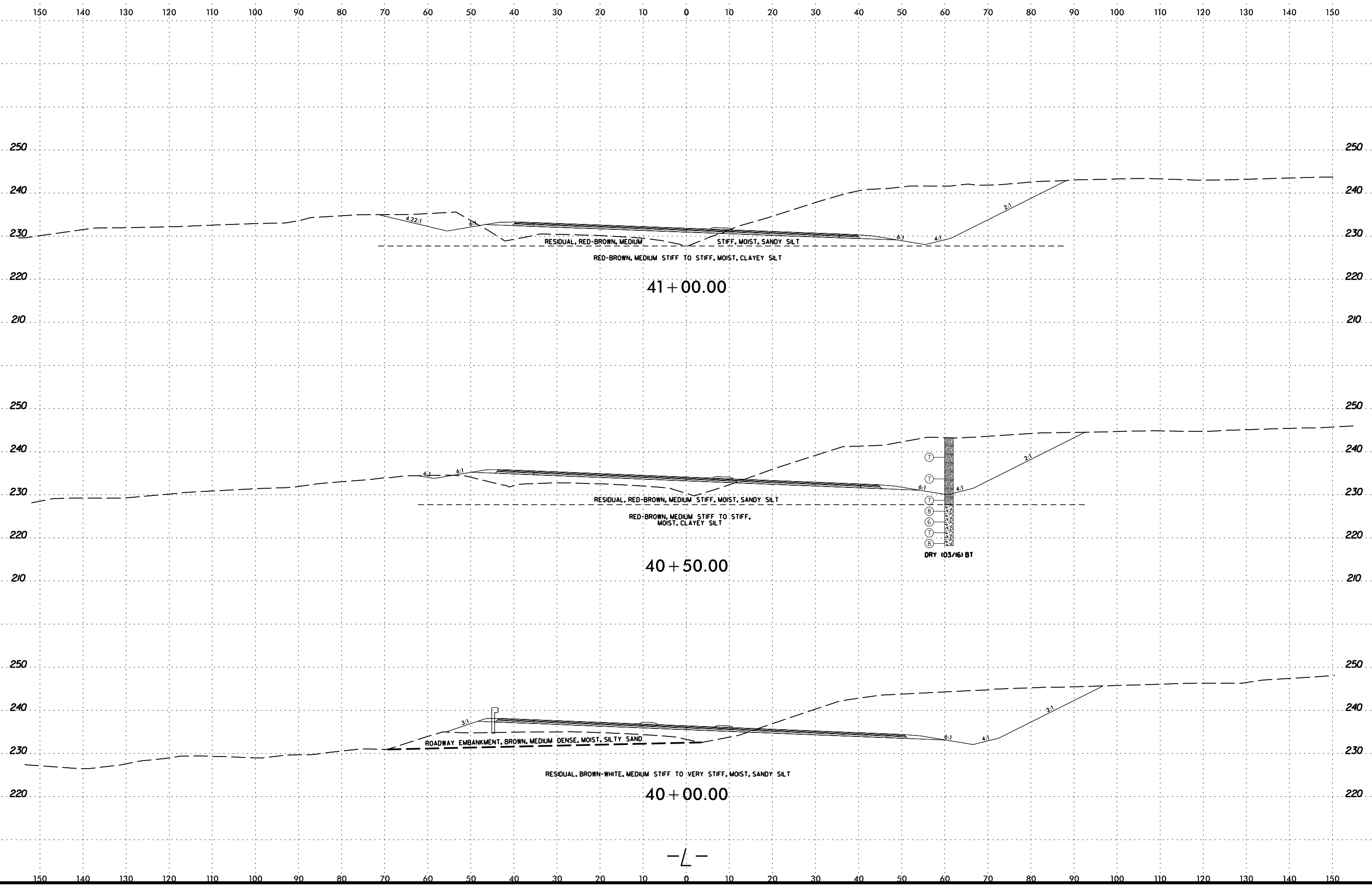

2/23/2017 11:58:00 AM C:\Users\mington\OneDrive\Documents\R-3825B\GEO\RDWY\modif\er\CA00.GEOTECH\sc\R3825B\_Geo\_xsi.1.(15+00-62+50).dgn

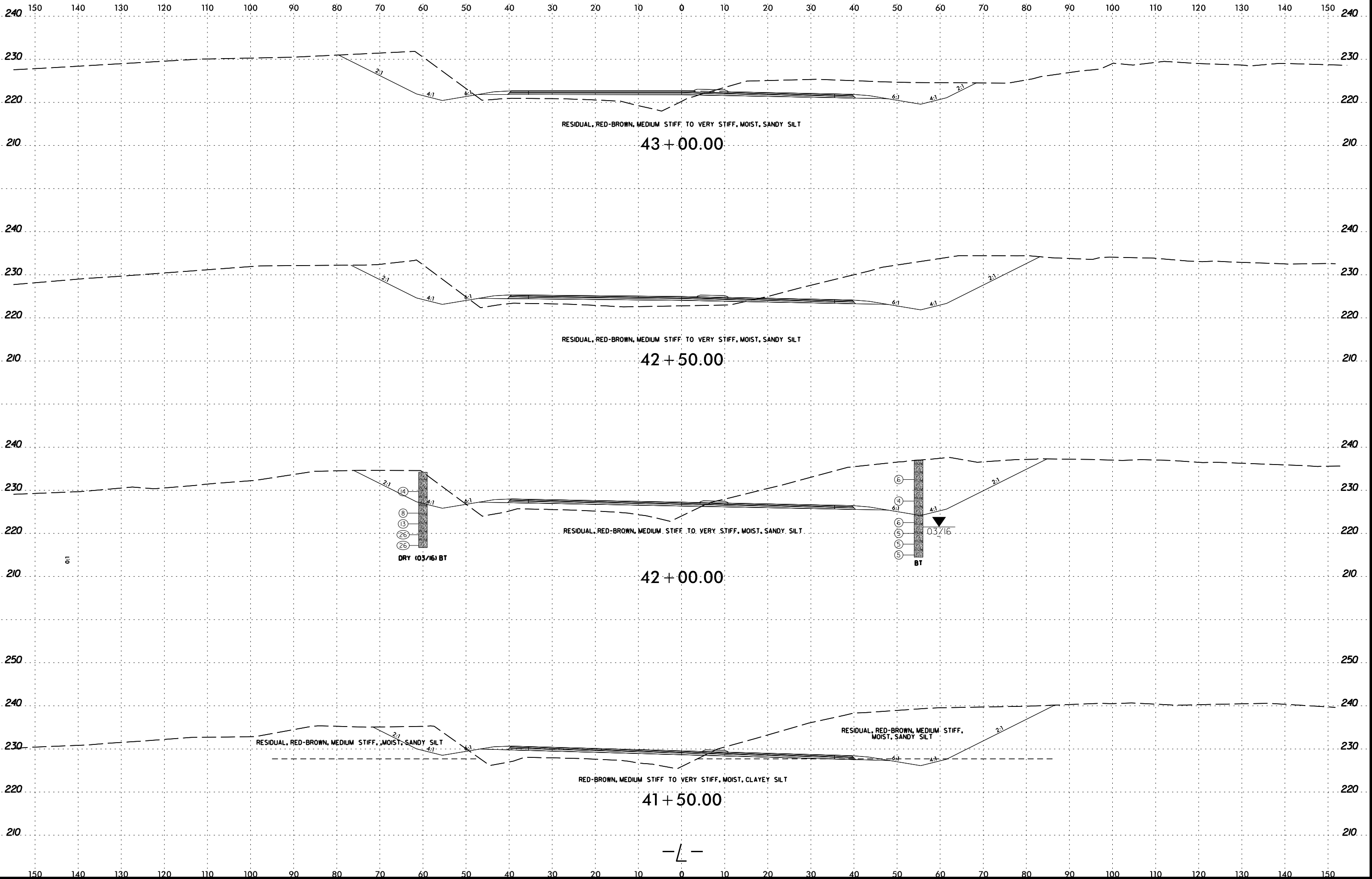

6/23/16

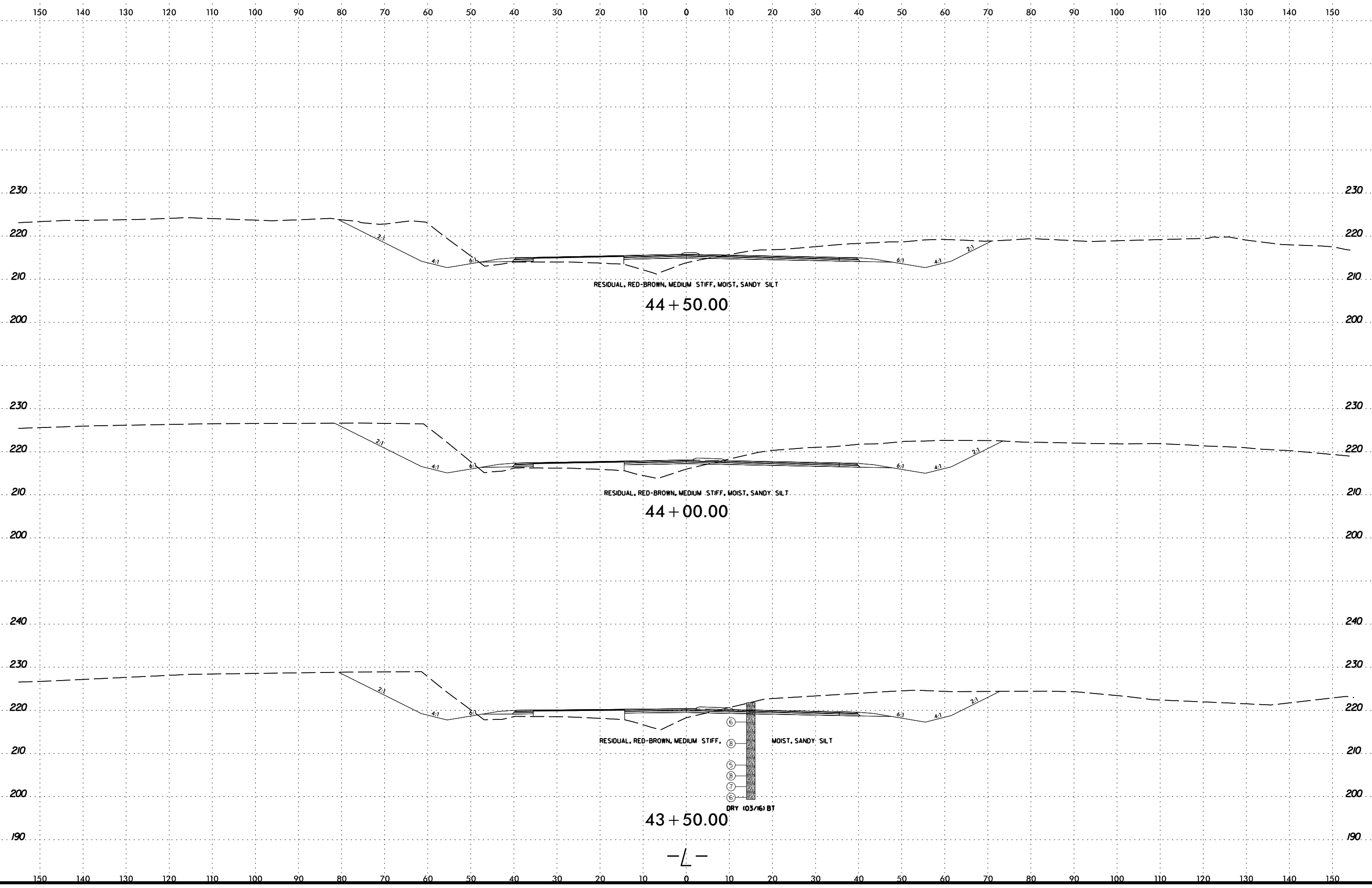

2/23/2017  
M:\N\CD01\R-3825B\R-3825B.GEO\_RDWY.mxd  
C:\Program Files\Autodesk\AutoCAD 2010\AutoCAD.exe





6/23/16

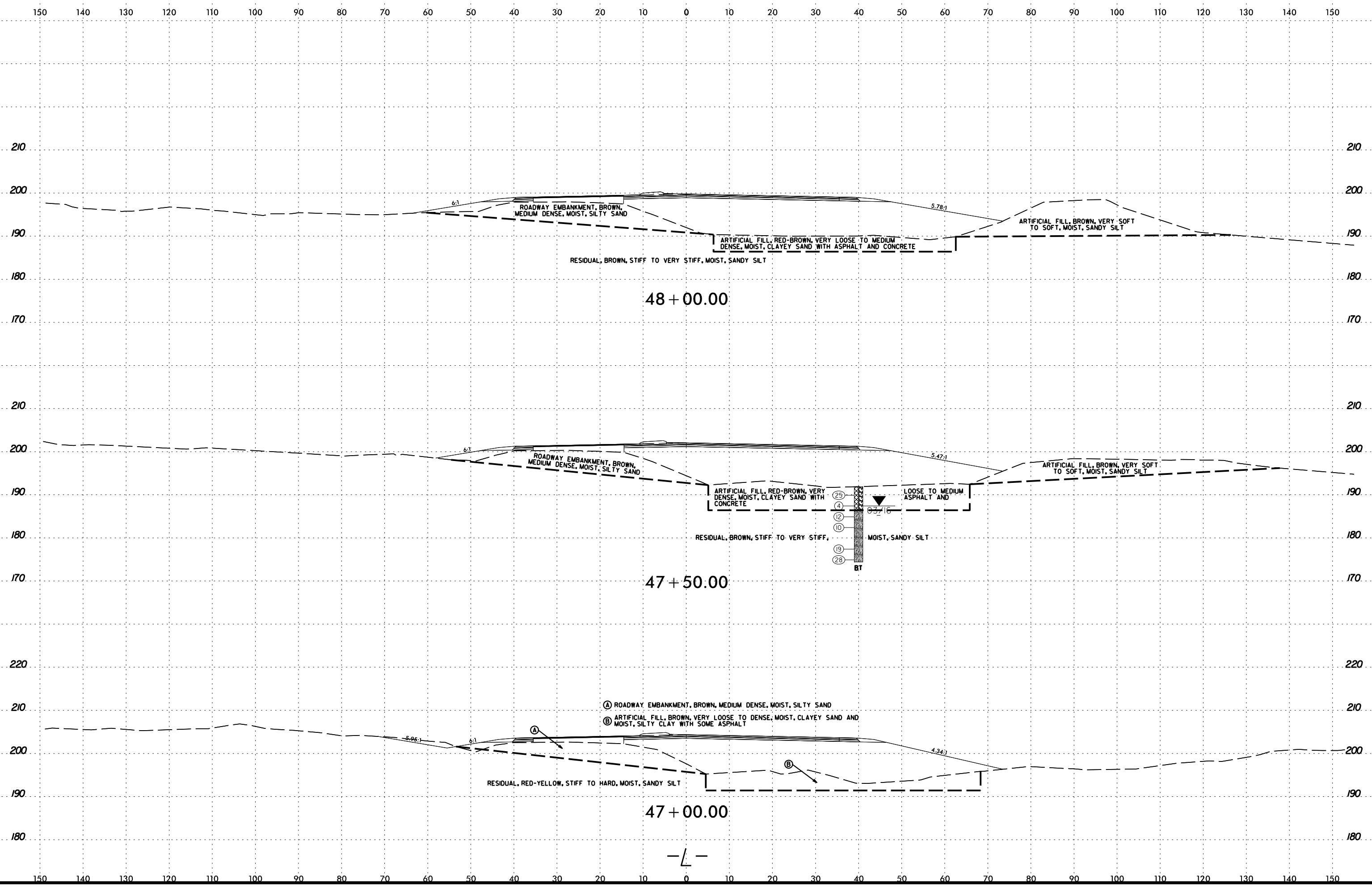

2/23/2017 11:51:11 AM C:\Users\mcc01\OneDrive\Documents\Projects\3825B\3825B\_GEO\RDWY.mxd\3825B\_GEO\RDWY.mxd\3825B\_GEO\3825B.dgn

6/23/16  
2/23/2017  
M:\N\NCD01\R-3825B\GEO\_RDWY.mxd  
C:\ur\imgton

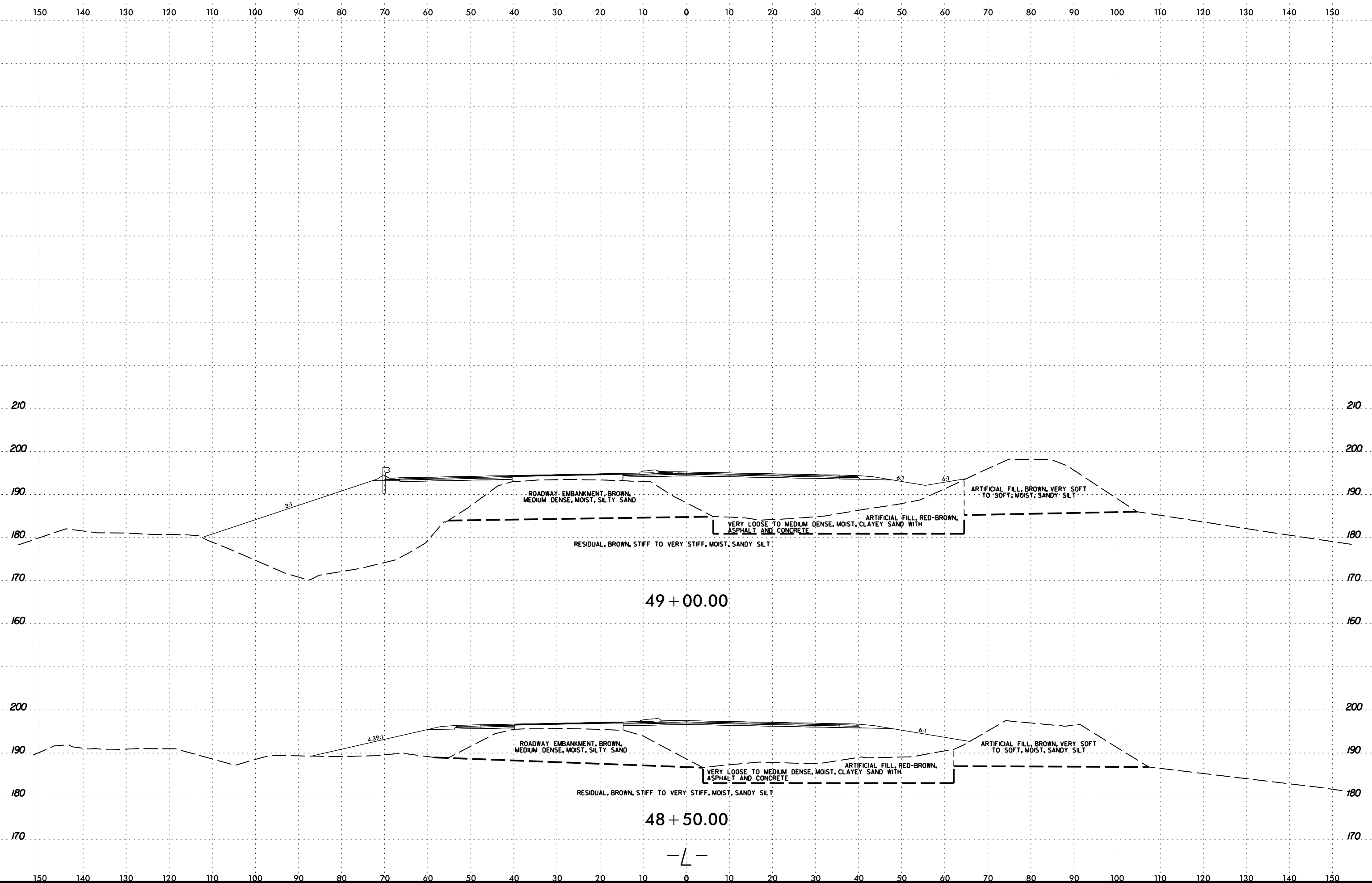

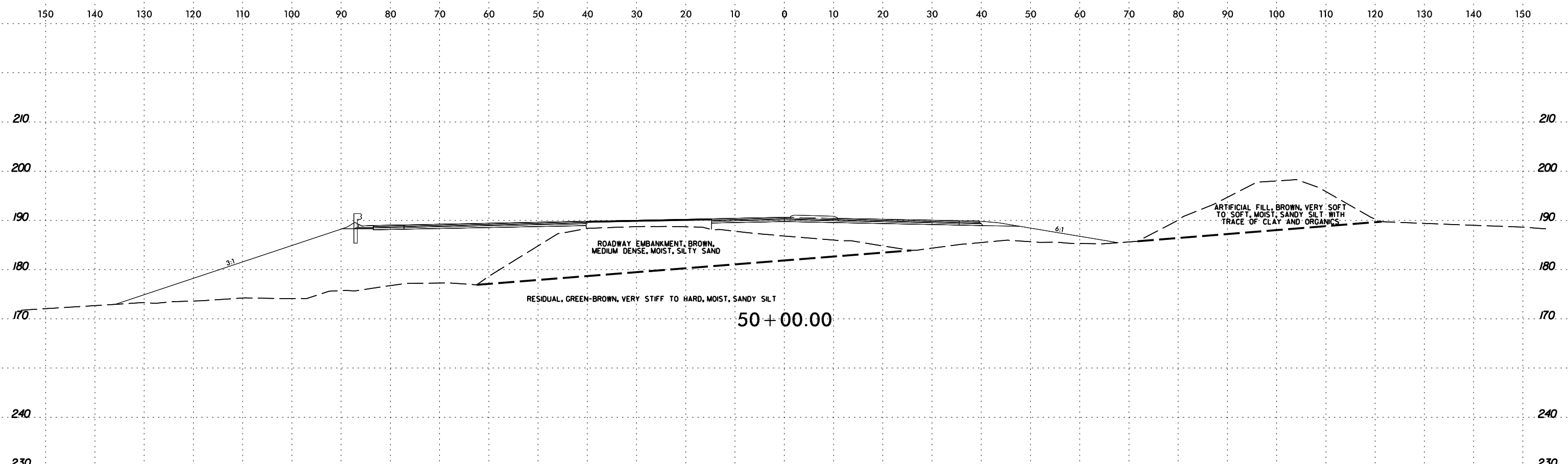

SOIL TEST RESULTS															
SAMPLE NO.	OFFSET	STATION	DEPTH INTERVAL	AASHTO CLASS.	L.L.	P.I.	% BY WEIGHT				% PASSING (SIEVES)			% MOISTURE	% ORGANIC
							C.SAND	F.SAND	SILT	CLAY	10	40	200		
SS-5	80' LT	49+50	1.0-2.5	A-4(2)	32	NP	10	45	28	10	99	94	56	18.9	-
SS-6	80' LT	49+50	3.5-4.5	A-4(3)	37	5	11	43	39	7	96	89	57	12.7	-
SS-7	80' LT	49+50	6.0-7.5	A-4(0)	31	NP	2	48	44	6	100	99	68	10	-
SS-8	80' LT	49+50	8.5-10.0	A-4(0)	32	NP	4	51	41	4	100	98	62	6.1	-

SOIL TEST RESULTS																
SAMPLE NO.	OFFSET	STATION	DEPTH INTERVAL	AASHTO CLASS.	L.L.	P.I.	% BY WEIGHT				% PASSING (SIEVES)			% MOISTURE	% ORGANIC	
							C.SAND	F.SAND	SILT	CLAY	10	40	200			
SS-9	50' RT	49+50	6.0-6.5	A-7-6(18)	45	21	-	4	24	35	37	94	92	76	26.6	-
ST-1	50' RT	49+50	9.0-11.0	-	-	-	-	-	-	-	-	-	-	-	-	-
SS-10	50' RT	49+50	8.5-10.0	A-4(2)	33	9	6	36	32	26	94	91	66	26.8	-	
SS-11	50' RT	49+50	13.5-14.4	A-4(1)	31	1	6	37	41	16	80	77	56	33.5	-	
SS-12	50' RT	49+50	14.4-15.0	A-5(13)	42	6	15	44	31	10	99	89	52	24.0	-	
SS-13	50' RT	49+50	16-17.5	A-4(7)	36	7	6	36	40	18	99	96	70	25.2	-	

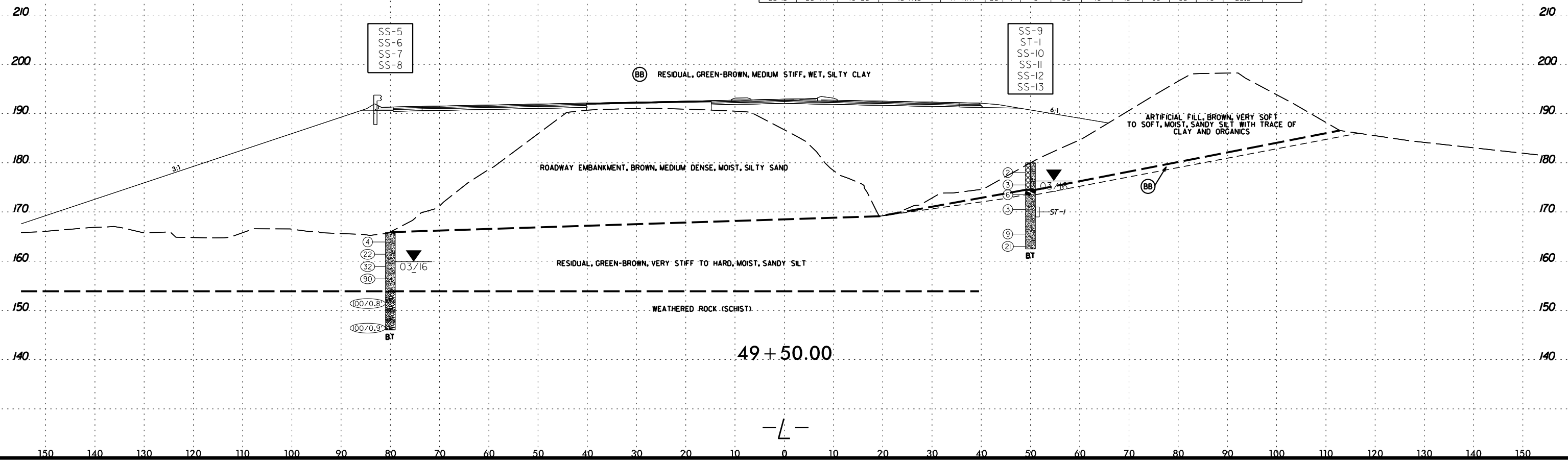

6/23/16

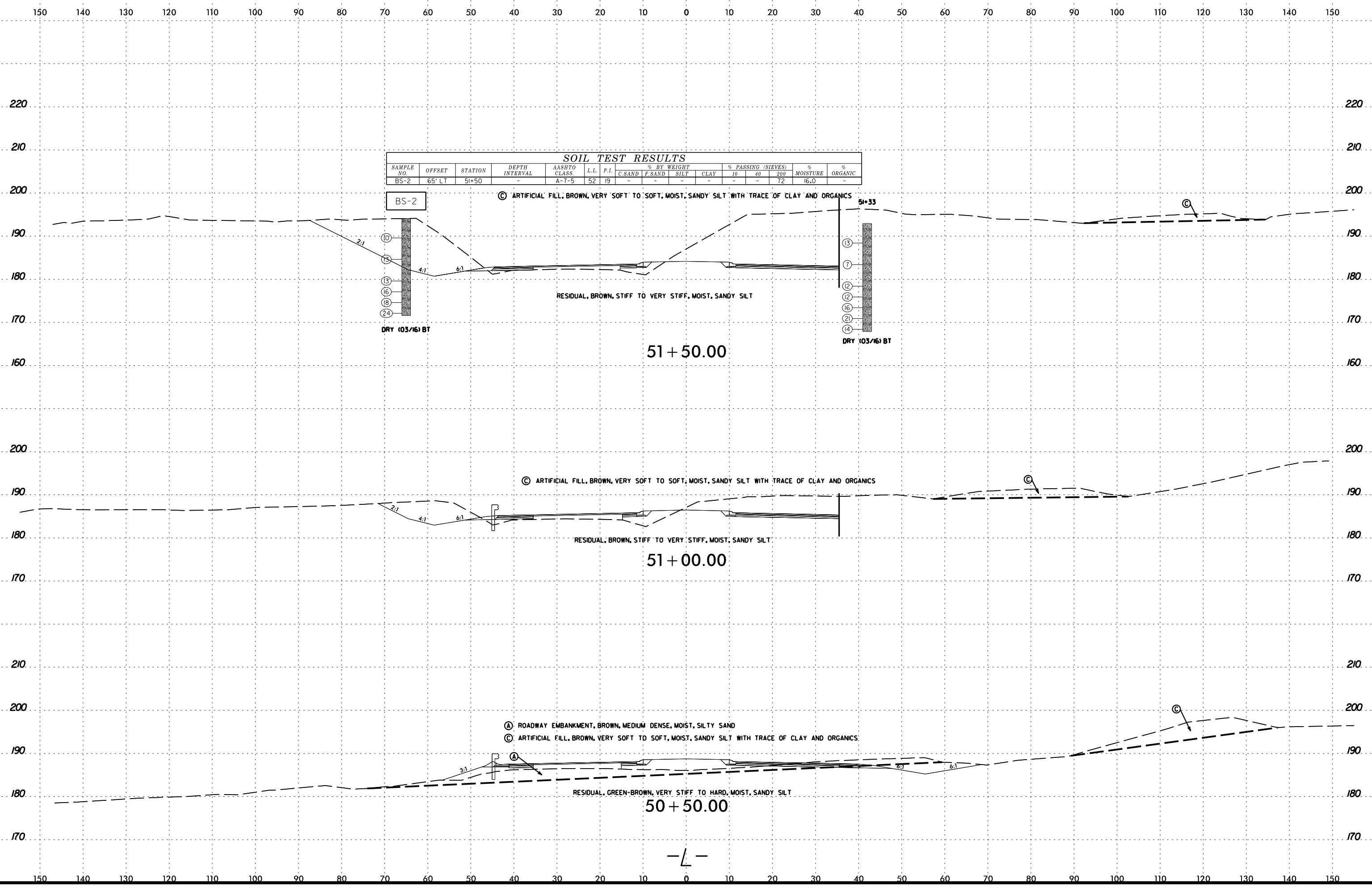

2/23/2017 11:58:00 AM C:\Users\matt\OneDrive\Documents\Projects\3825B\3825B\_GEO\RDWY\modif\ter\CA00D\_GEO\TECH\sc\3825B\_Geo\_xsi.1.(15+00-62+50).dgn





6/23/16

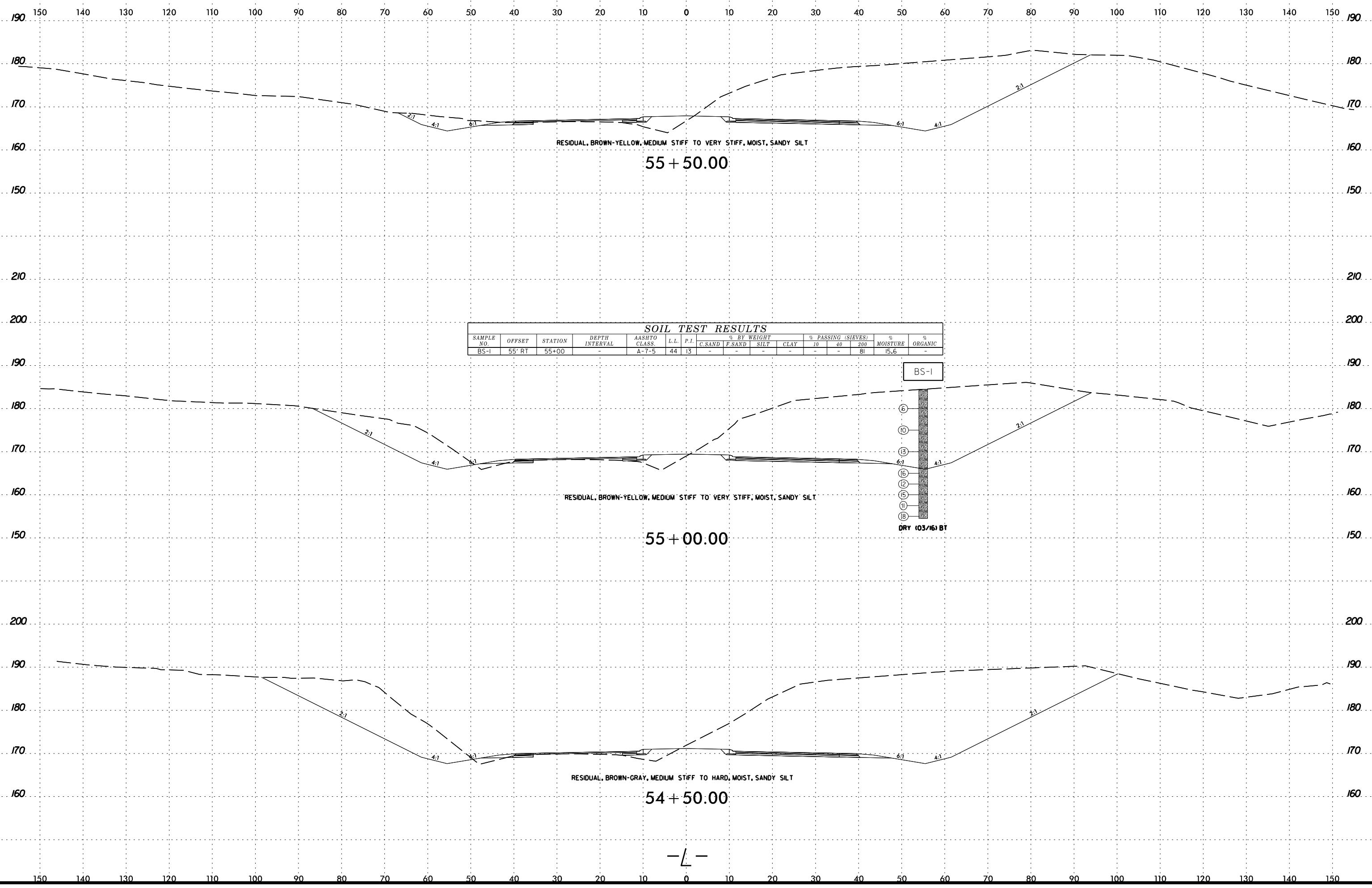

**SOIL TEST RESULTS**

SAMPLE NO.	OFFSET	STATION	DEPTH INTERVAL	AASHTO CLASS.	L.L.	P.I.	% BY WEIGHT				% PASSING (SIEVES)			MOISTURE	% ORGANIC
							C.SAND	F.SAND	SILT	CLAY	10	40	200		
BS-1	55' RT	55+00	-	A-7-5	44	13	-	-	-	-	-	-	81	15.6	-

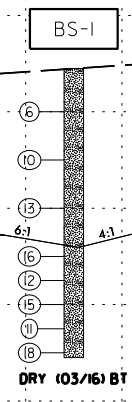

2/23/2017  
 M:\N\CD01\R-3825B\R-3825B.GEO\_RDWY.mxd  
 C:\Users\imington

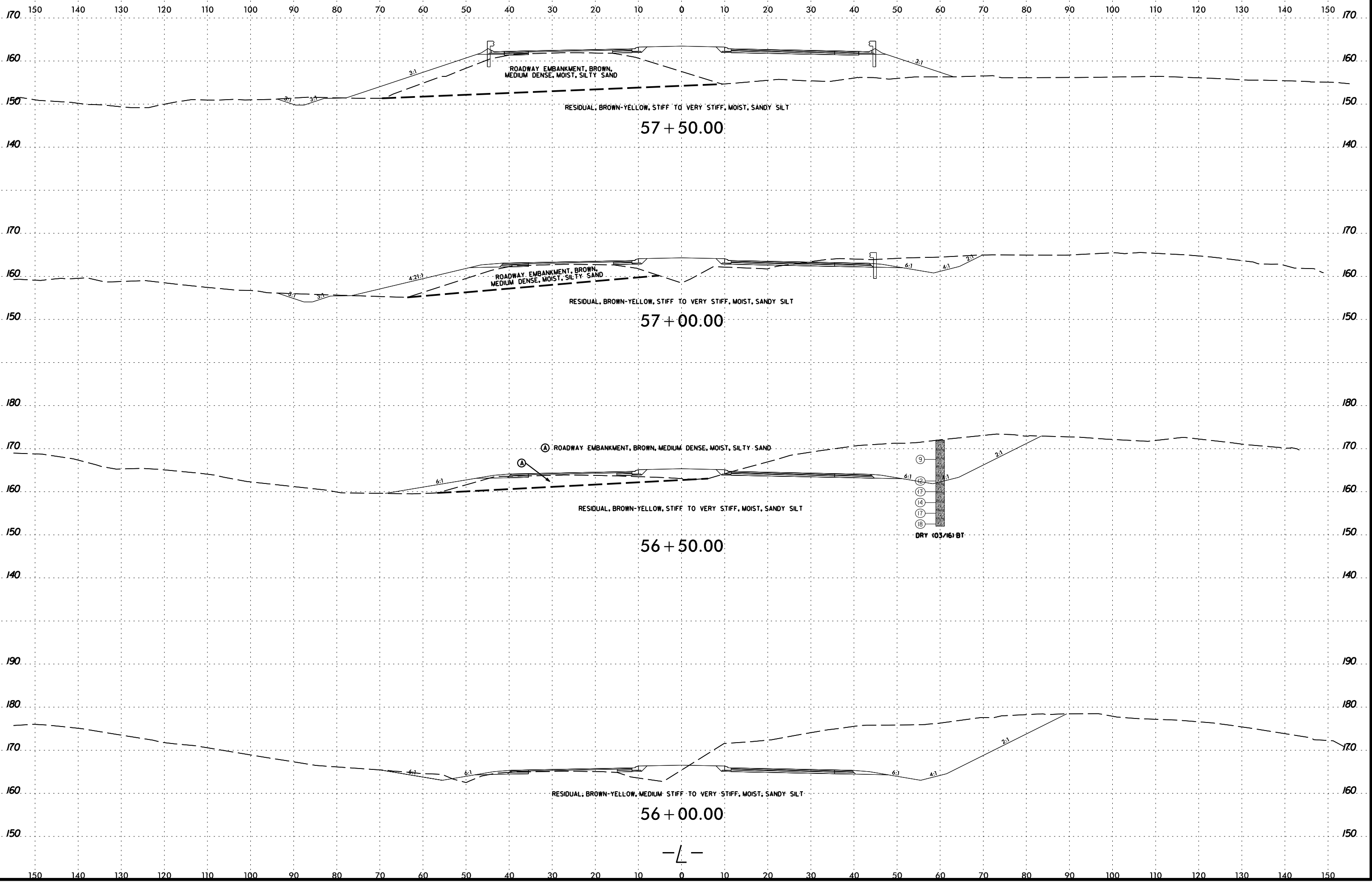



6/23/16

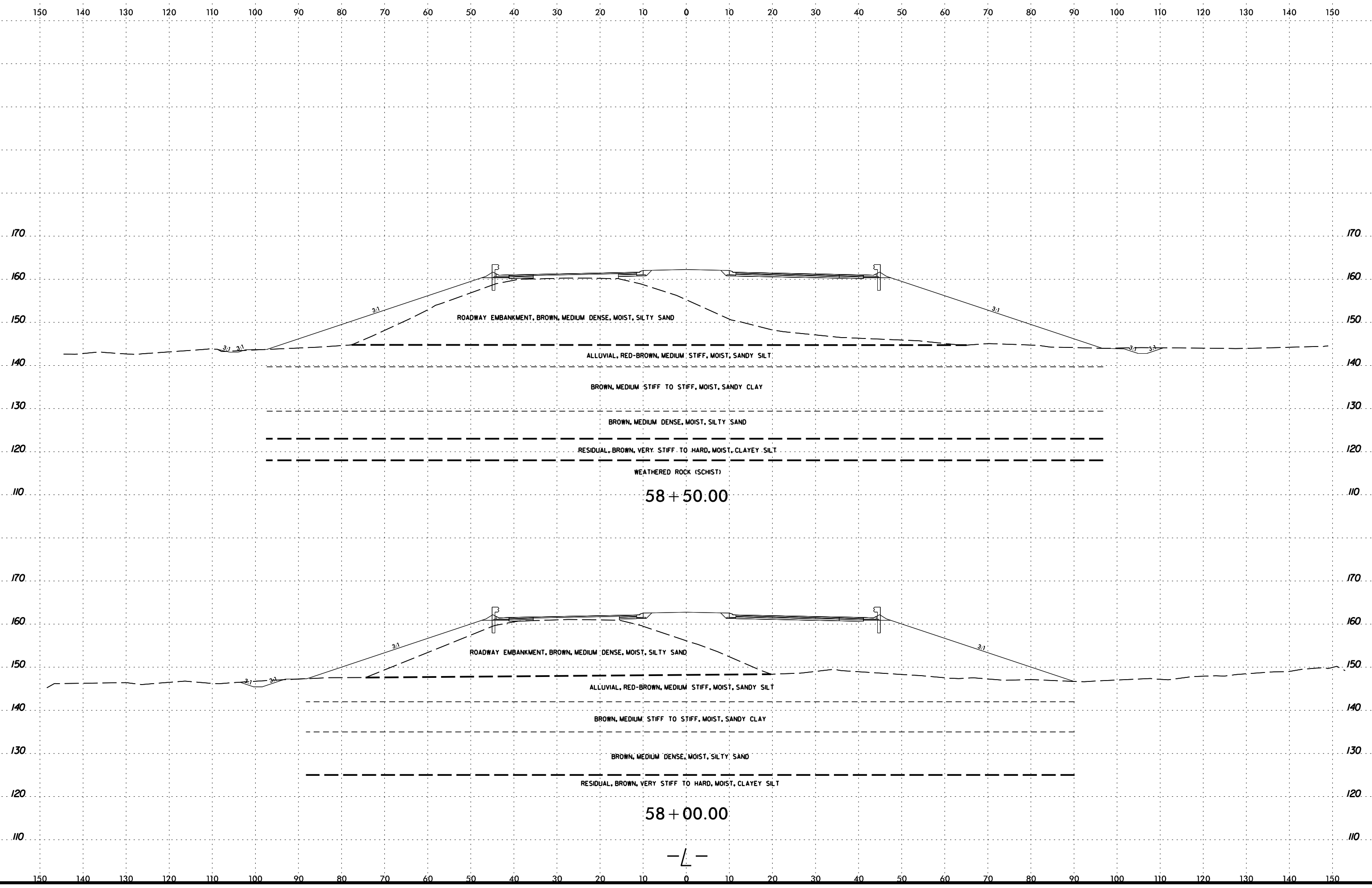

2/23/2017  
C:\Users\mcc01\OneDrive\Documents\2017\Projects\3825B\GEO\RDWY\modif\ter\CA00\_GEO1TECH\sc\3825B\_Geo\_xsi.1 (15+00-62+50).dgn



6/23/16

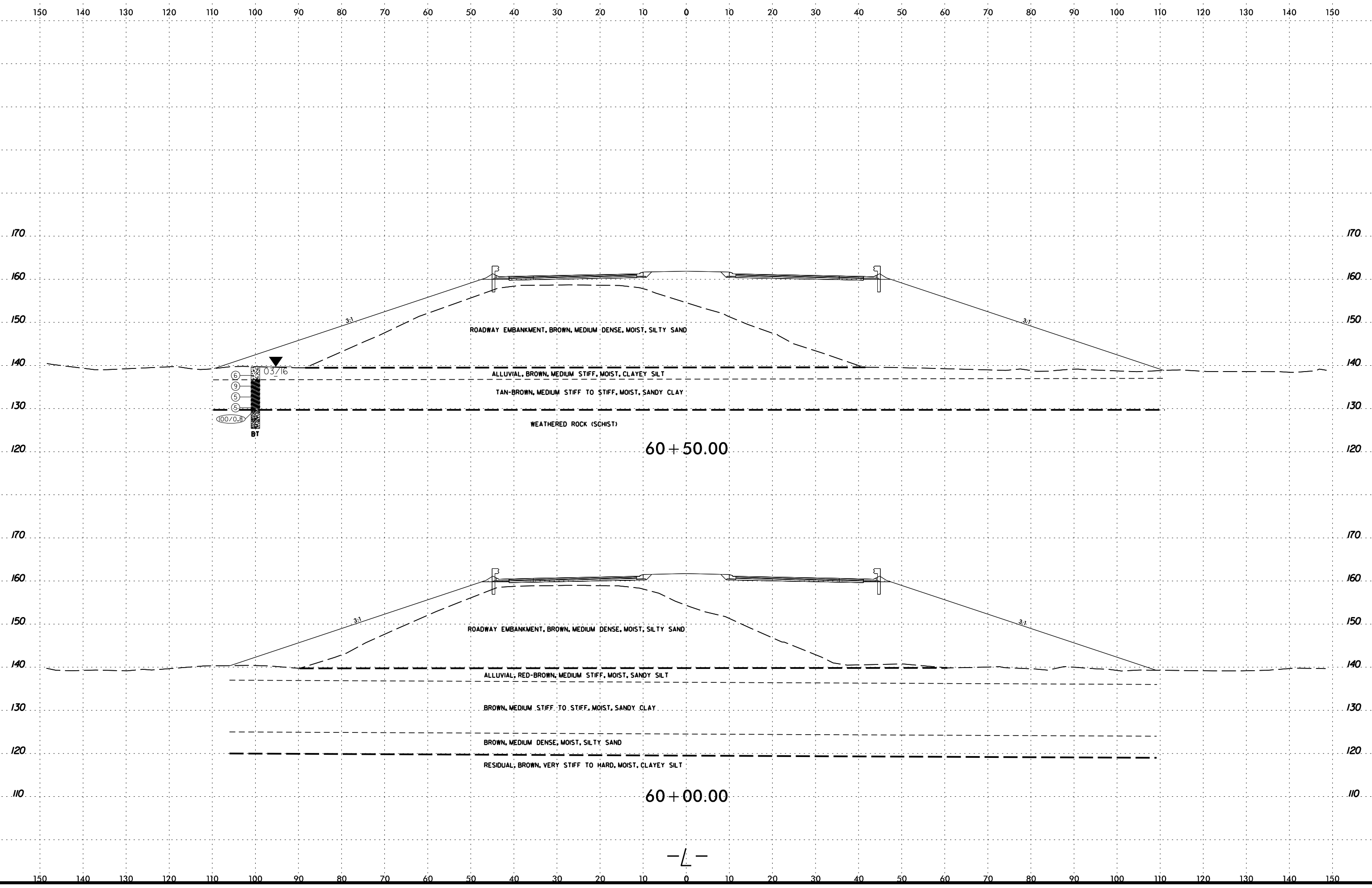

2/23/2017  
C:\Users\mcc01\OneDrive\Documents\Projects\3825B\GEO\RDWY.mxd\ref\CA00\_GEO\TECH\sc\3825B\_Geo\_xsi.1 (15+00-62+50).dgn

6/23/16

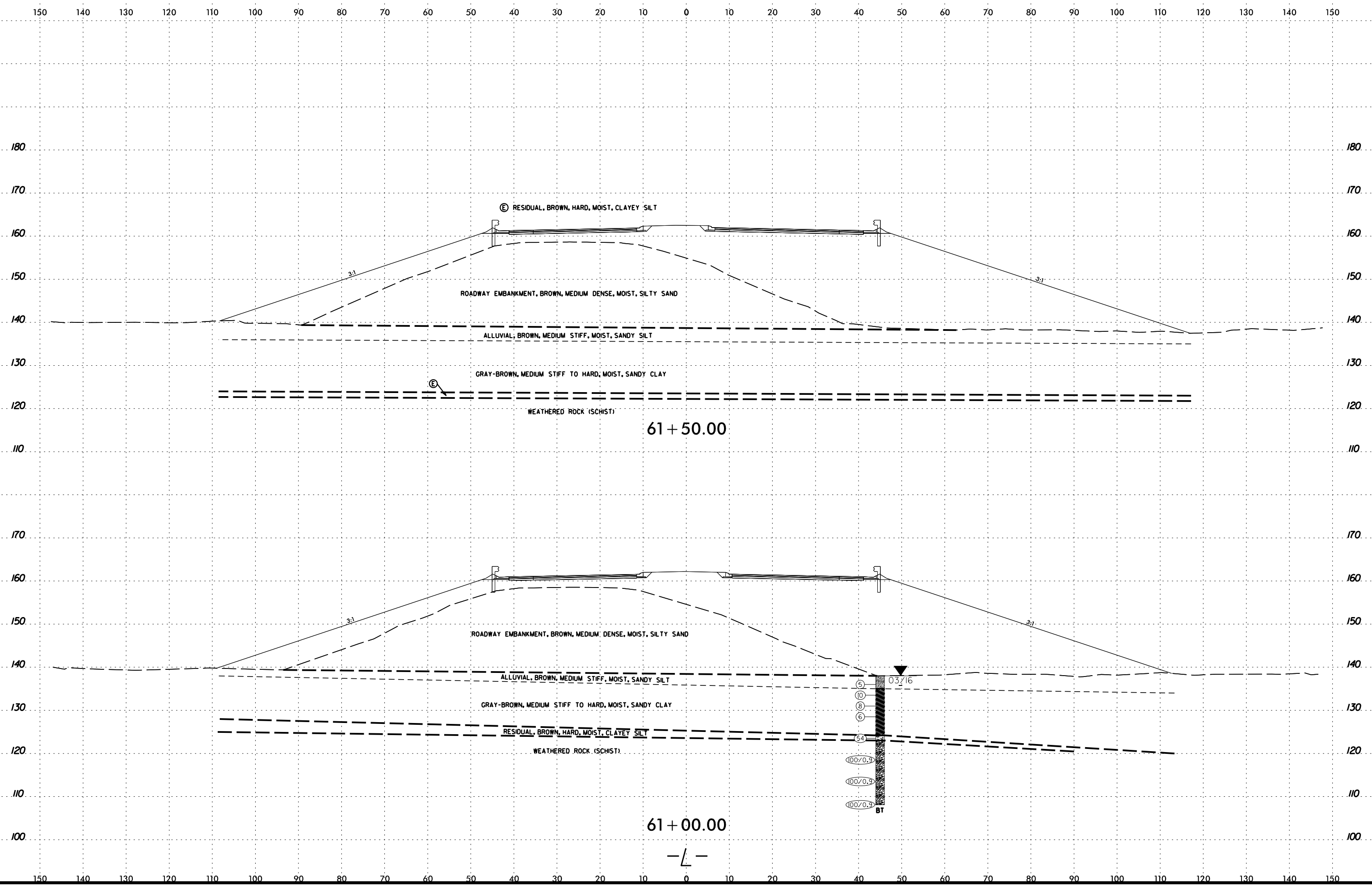

2/23/2017  
C:\Users\mcc01\OneDrive\Documents\Projects\3825B\GEO\RDWY\modif\er\CA00\_GEO\TECH\sc\3825B\_Geo\_xsl.1.(15+00-62+50).dgn





6/23/16

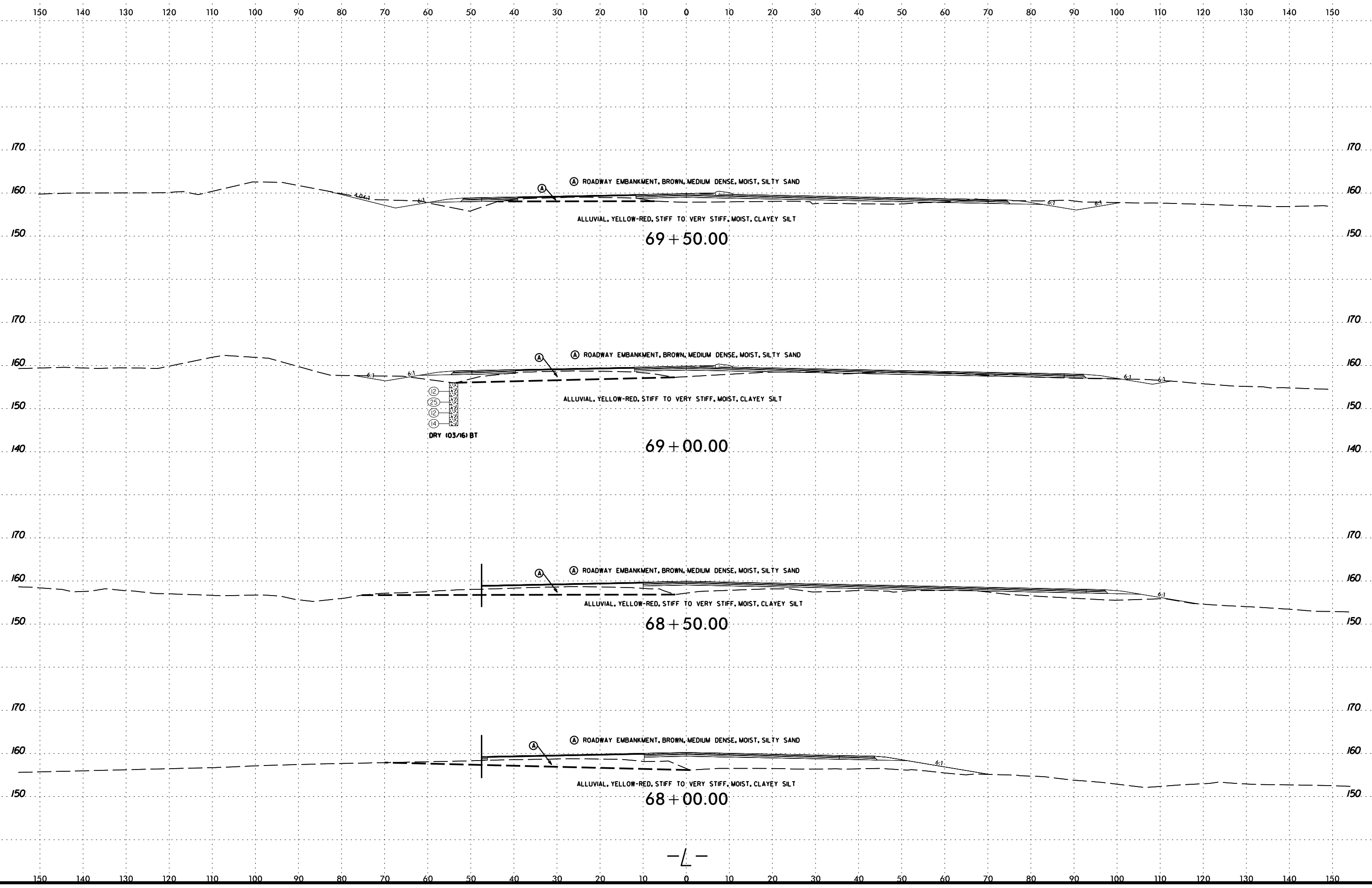

2/23/2017  
M:\N\NCD01\R-3825B\R-3825B\_GEO\_RDWY.mxd  
C:\Users\lmgton

6/23/16

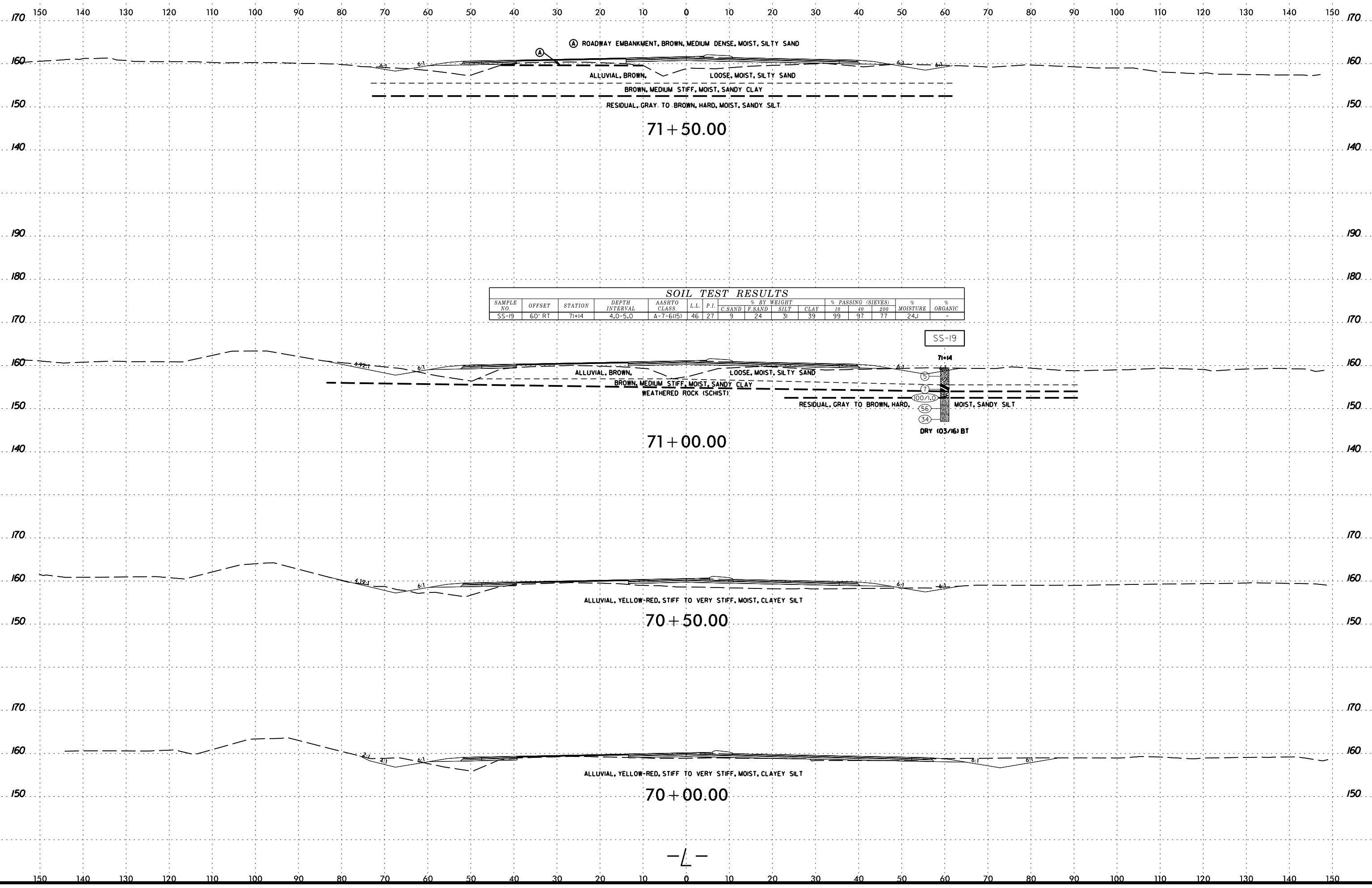

2/23/2017  
M:\N\NCD01\R-3825B\R-3825B.GEO.RDWY.mxd  
C:\Users\imington



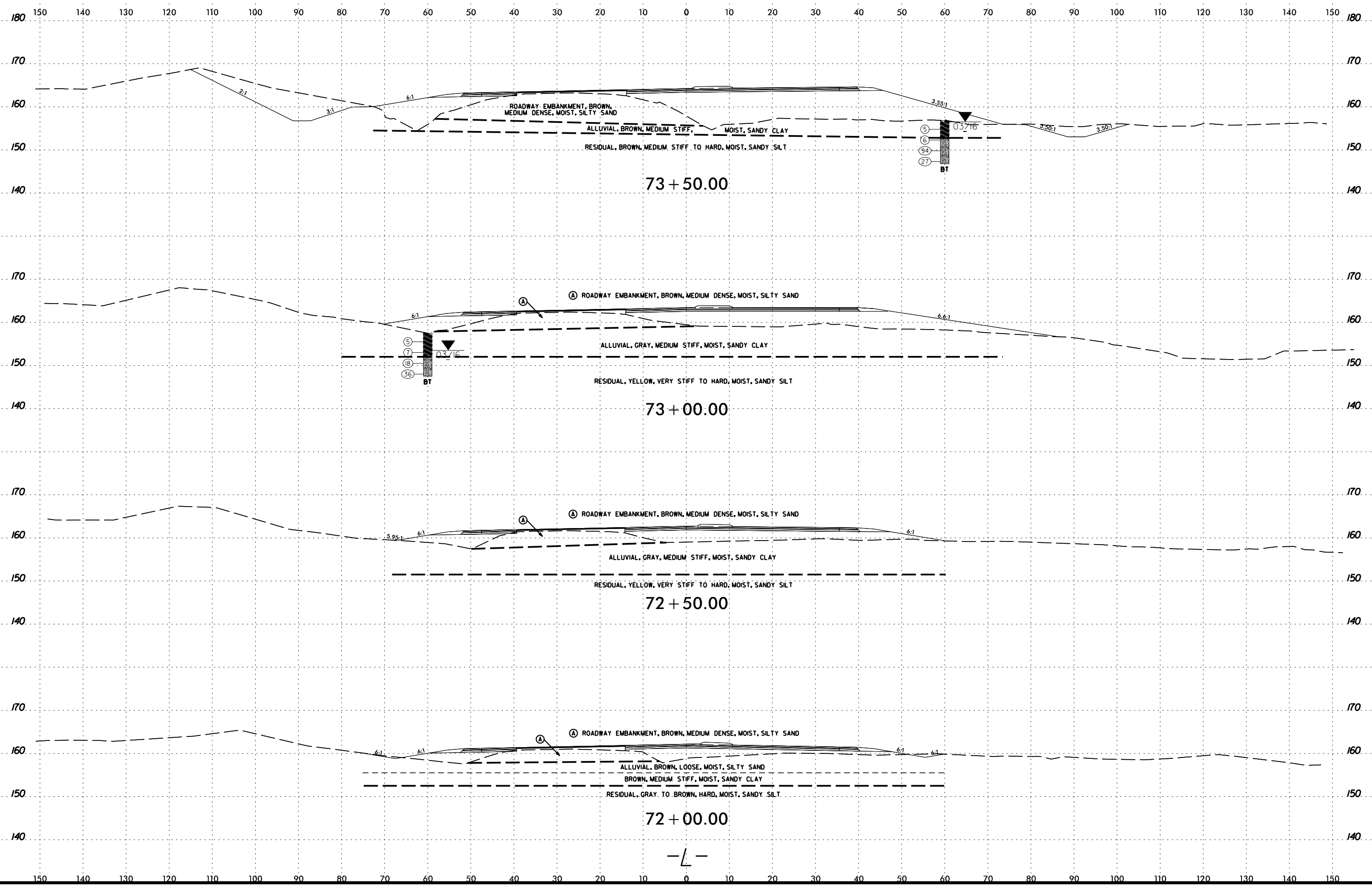

6/23/16

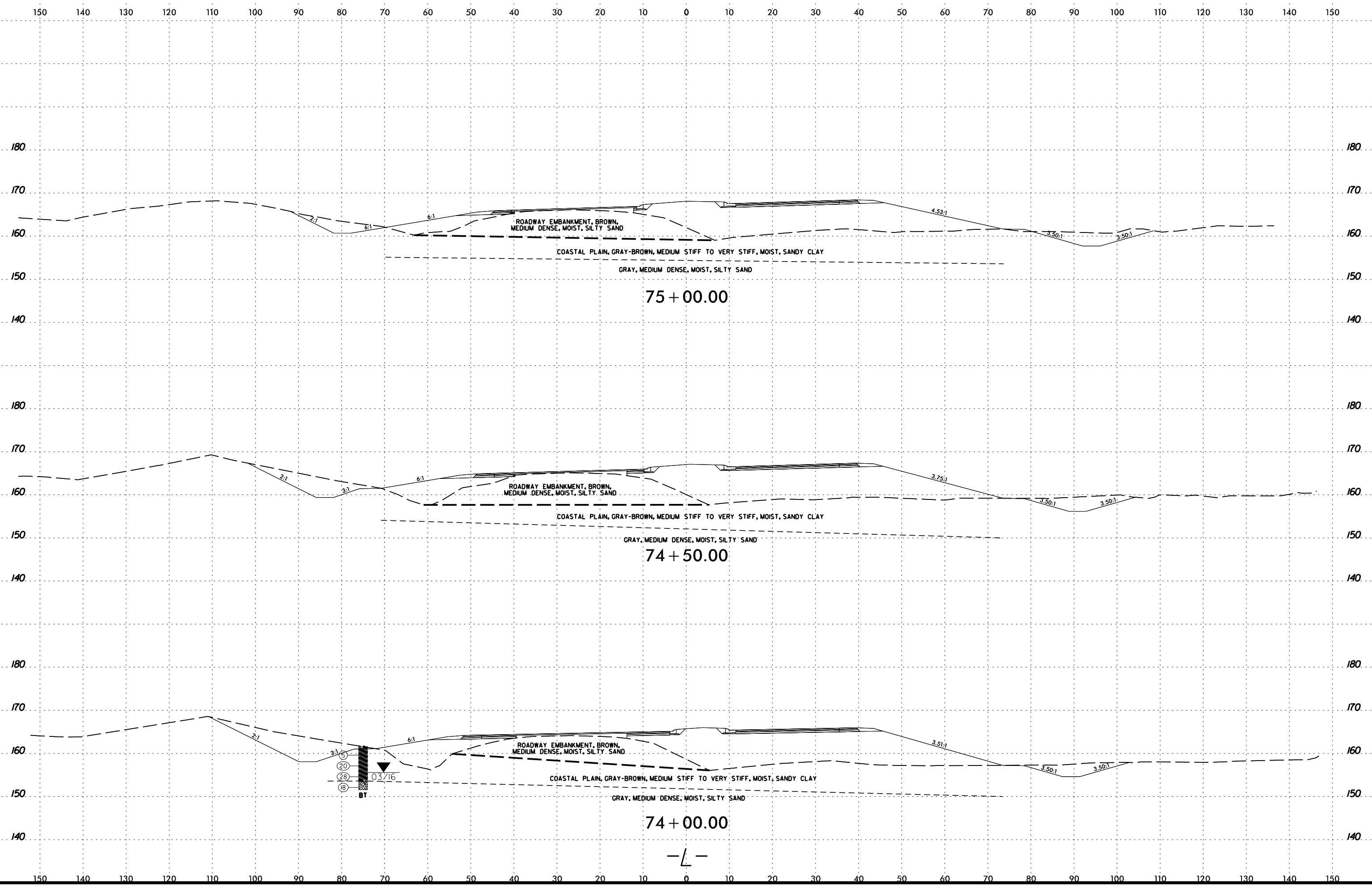

2/23/2017  
 M:\N\NCD01\R-3825B\R-3825B\_GEO\_RDWY.mxd  
 C:\Program Files\Autodesk\AutoCAD 2010\AutoCAD.exe  
 C:\Program Files\Autodesk\AutoCAD 2010\AutoCAD.exe

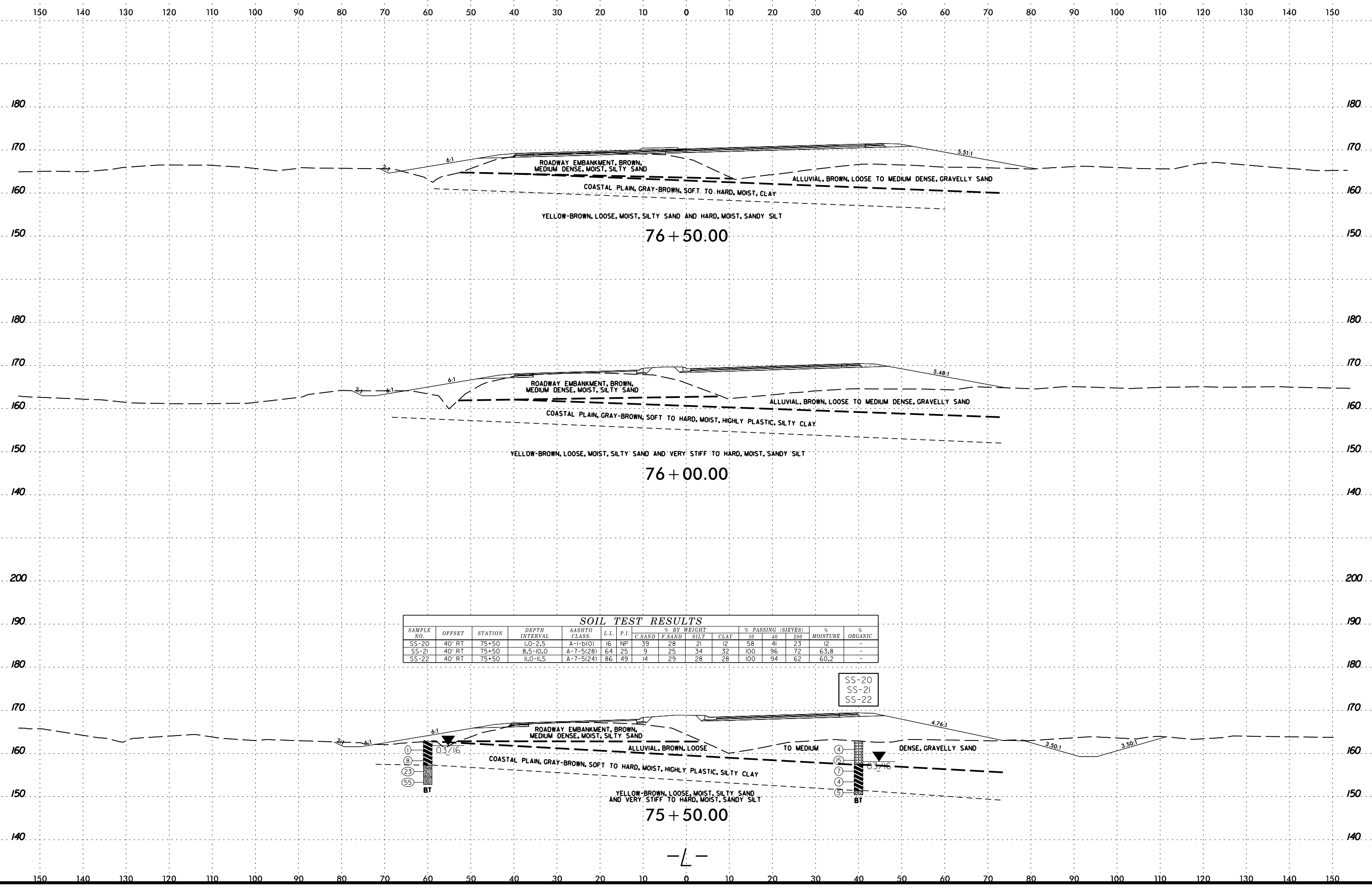

**SOIL TEST RESULTS**

SAMPLE NO.	OFFSET	STATION	DEPTH INTERVAL	AASHTO CLASS.	L.L.	P.I.	% BY WEIGHT				% PASSING (SIEVES)			% MOISTURE	% ORGANIC
							C. SAND	F. SAND	SILT	CLAY	10	40	200		
SS-20	40' RT	75+50	1.0-2.5	A-1-b(0)	16	NP	39	28	21	12	58	41	23	12	-
SS-21	40' RT	75+50	8.5-10.0	A-7-5(28)	64	25	9	25	34	32	100	96	72	63.8	-
SS-22	40' RT	75+50	11.0-11.5	A-7-5(24)	86	49	14	29	28	28	100	94	62	60.2	-

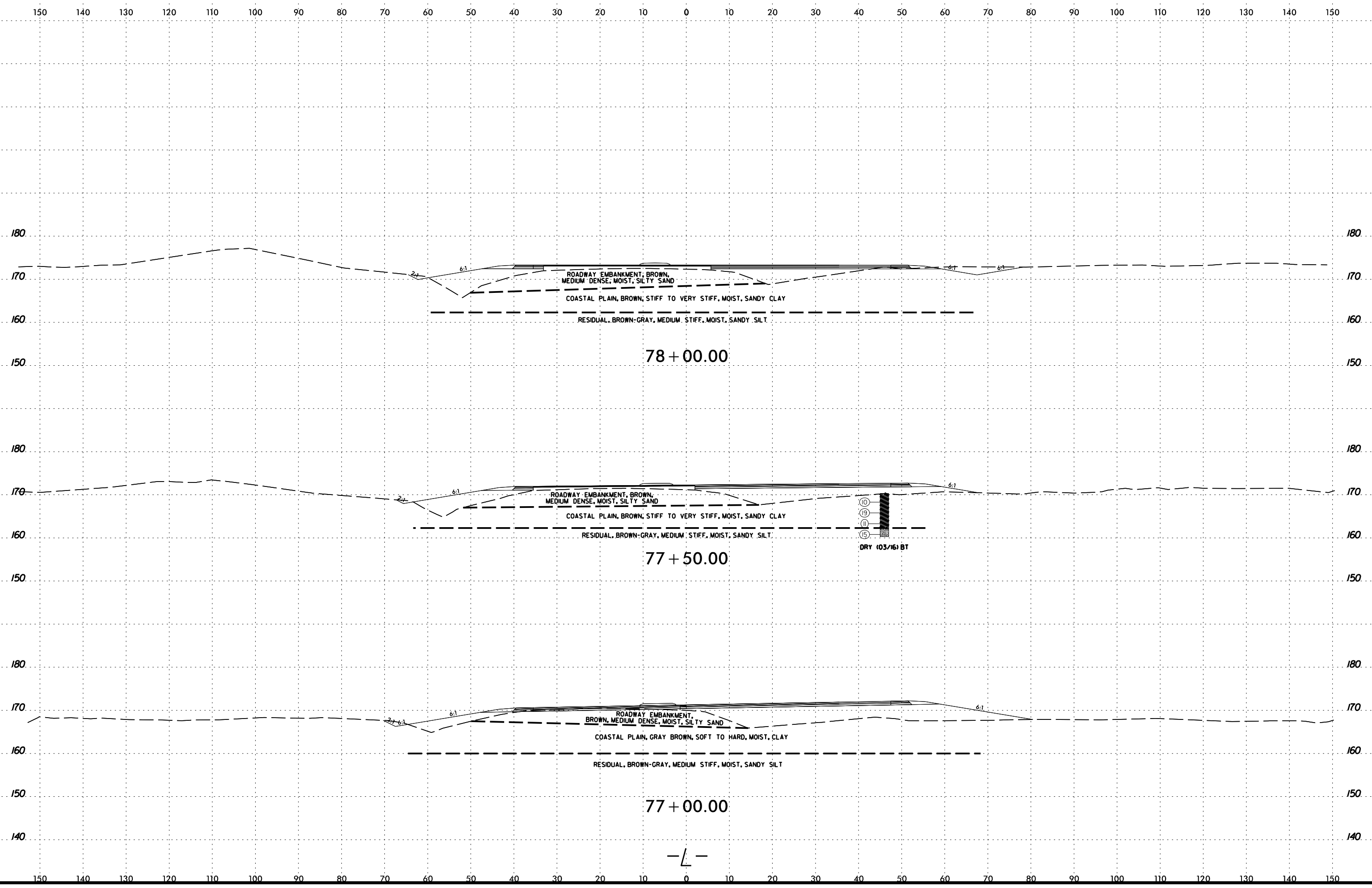

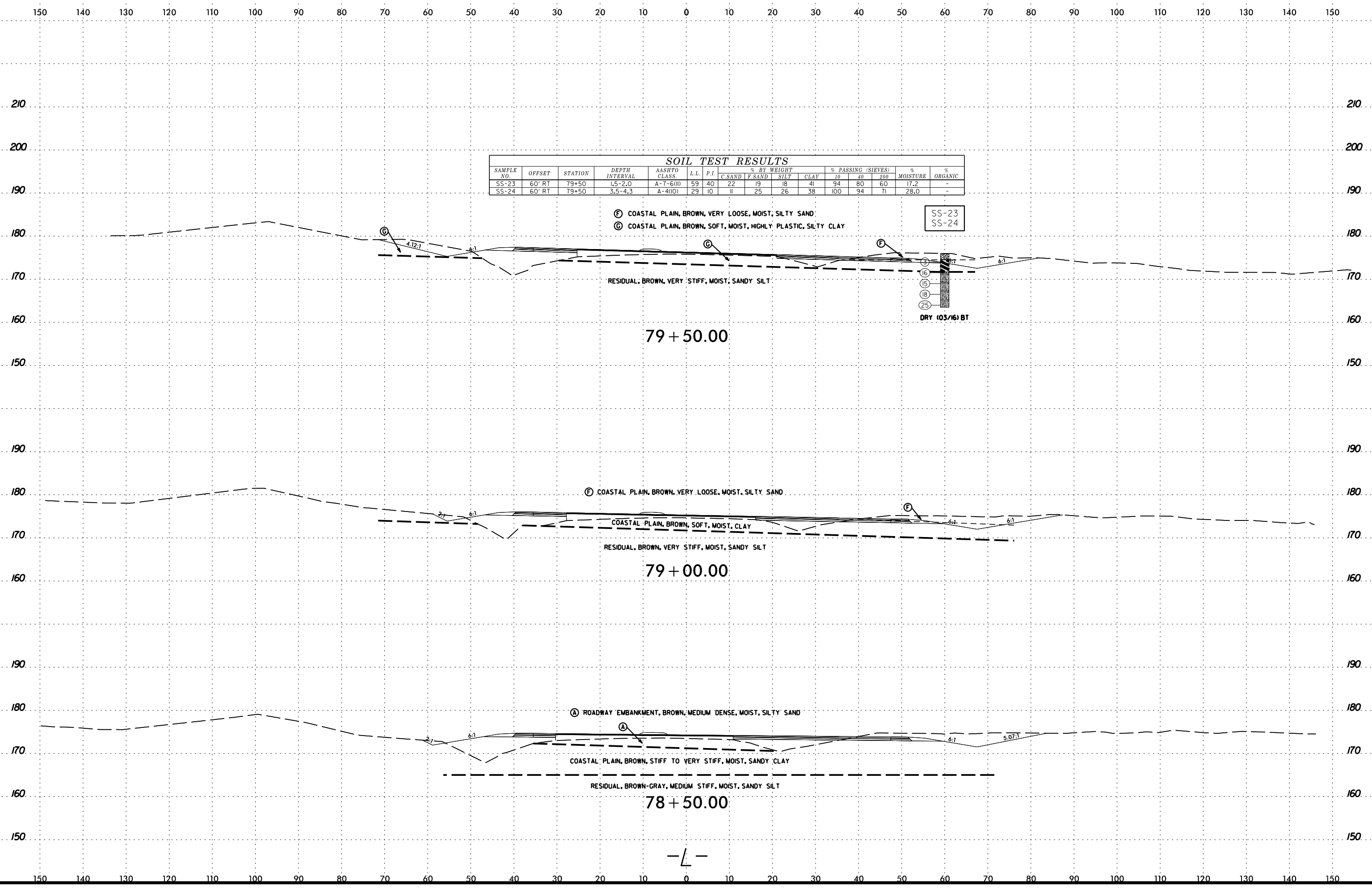

6/23/16

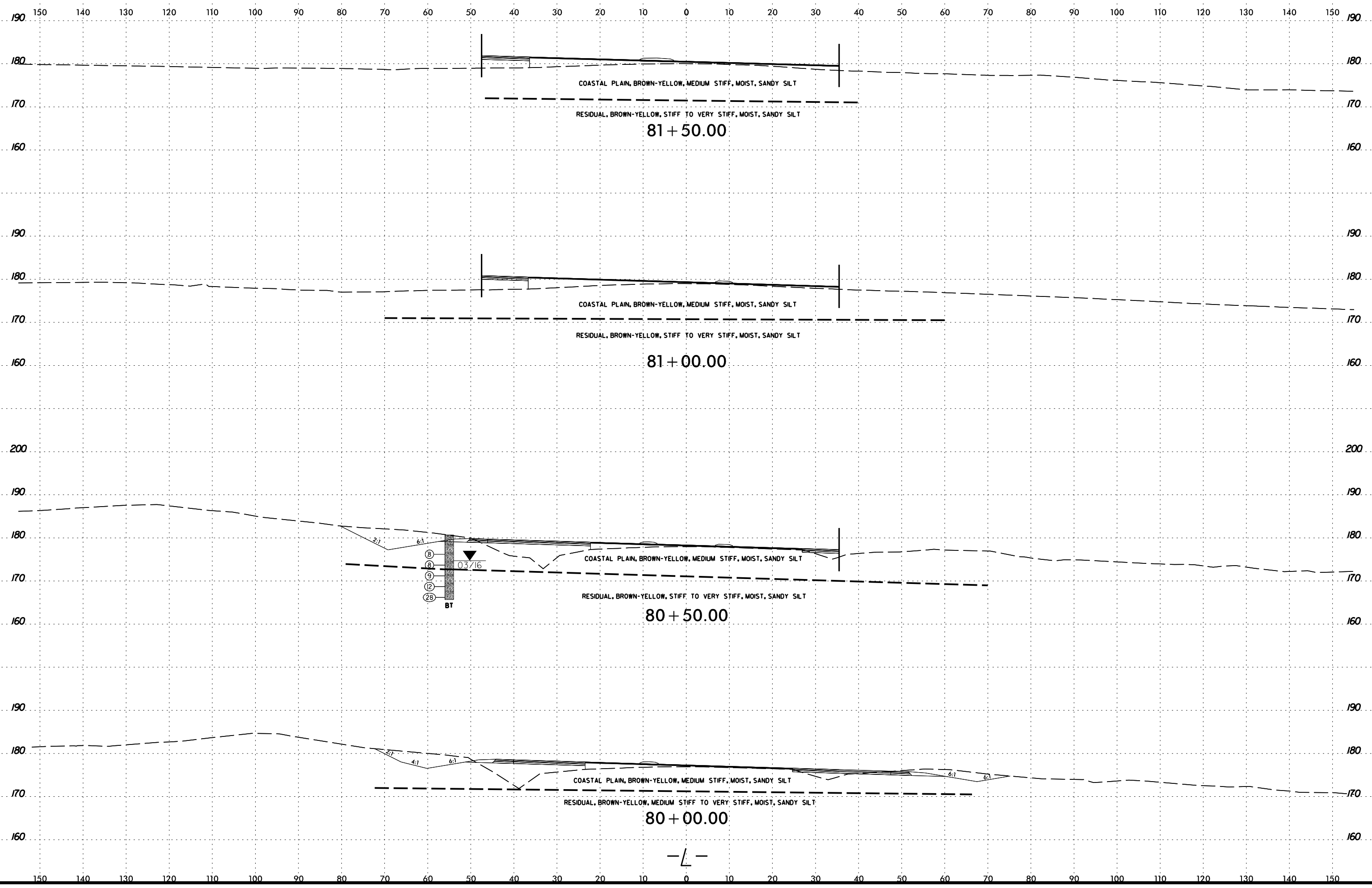

2/23/2017  
M:\N\NCD01\R-3825B\GEO.RDWY...modif\er\CA00.GEOTECH\sc\R3825B\_Geo\_xsi.1.166+50-257+70.dgn  
C:\ur\imgton

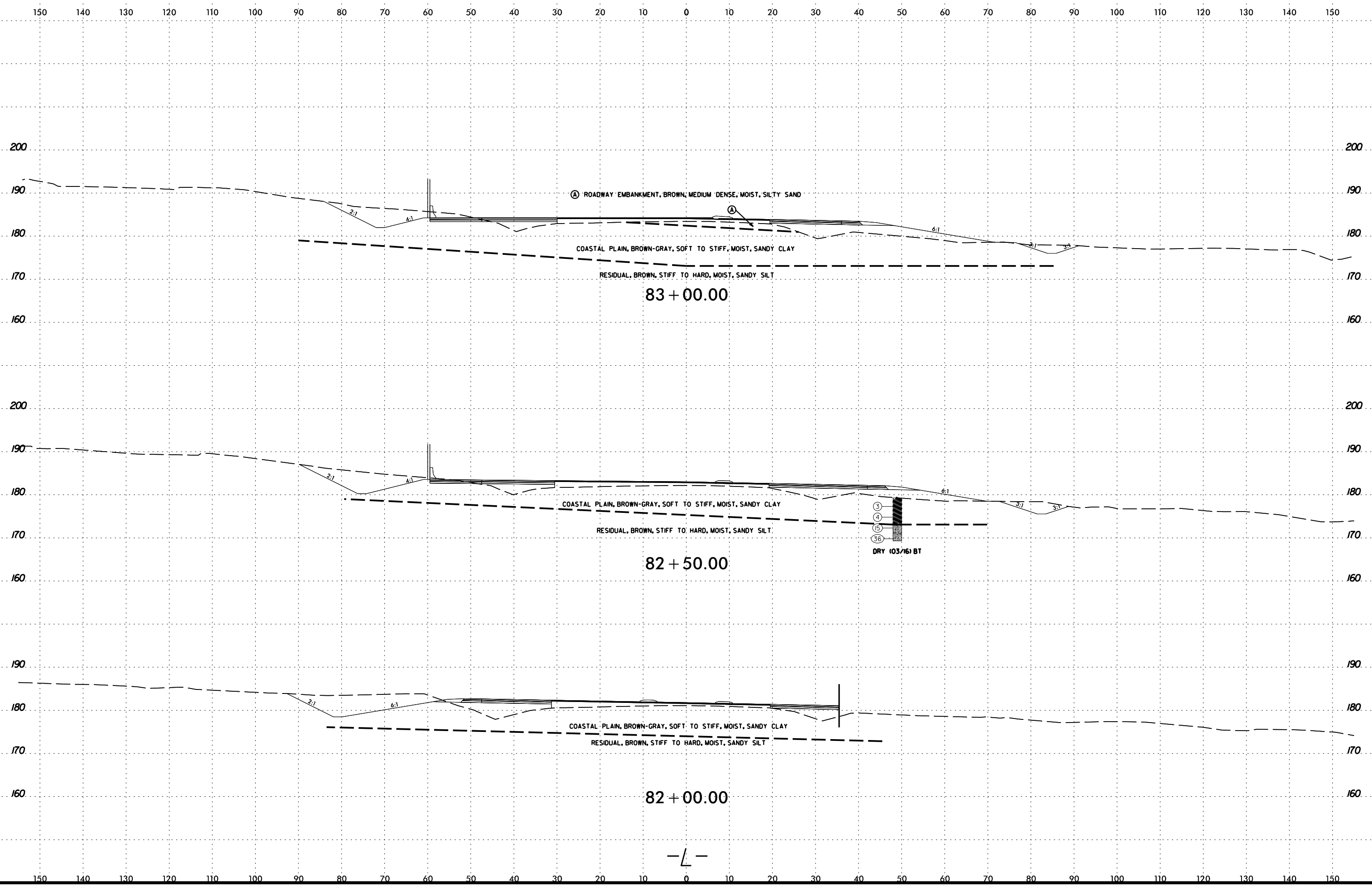

6/23/16

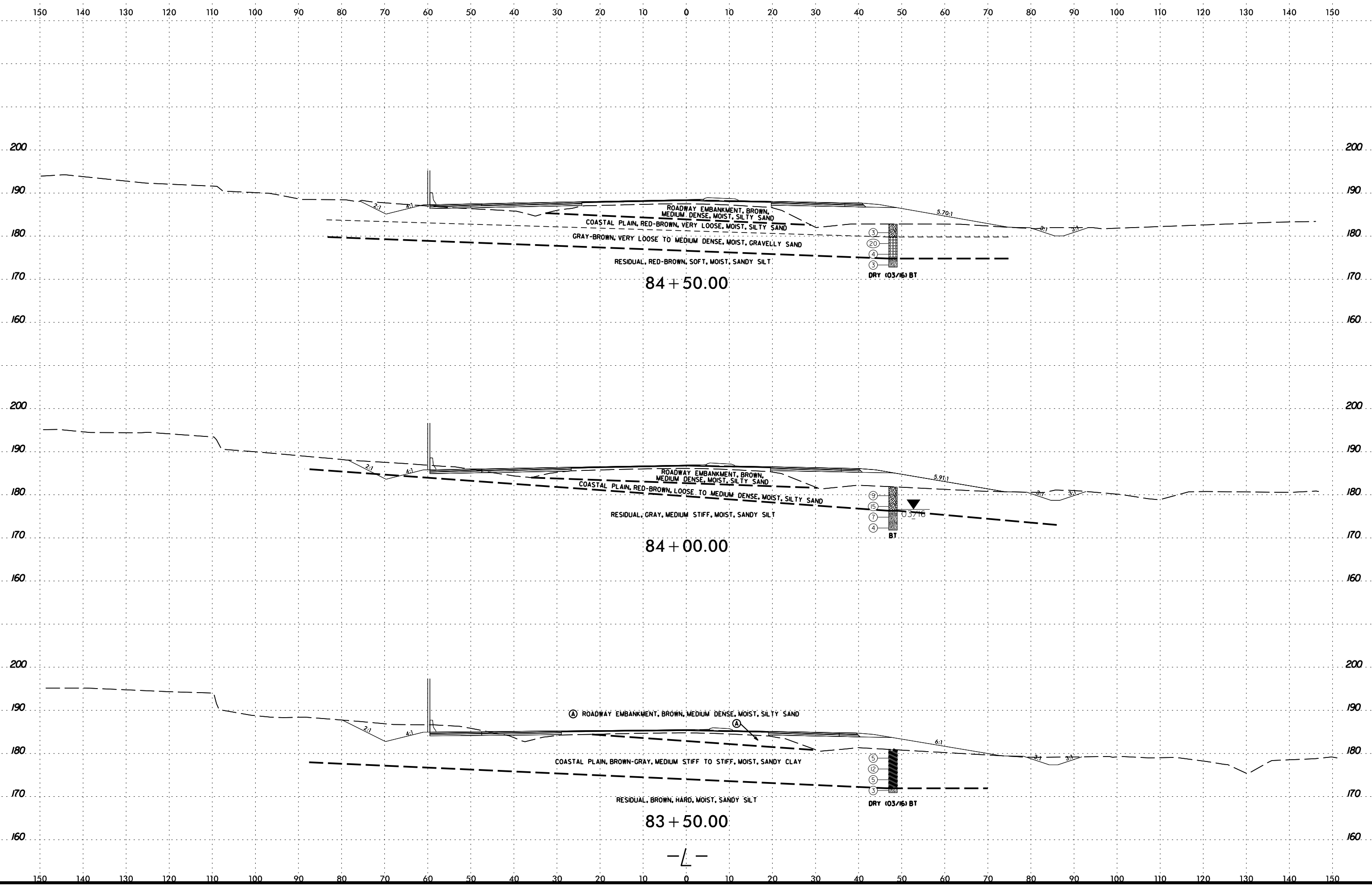

2/23/2017  
M:\N\2001\R-3825B\GEO.\RDWY.mxd  
C:\Program Files\Autodesk\AutoCAD 2010\bin\acad.exe



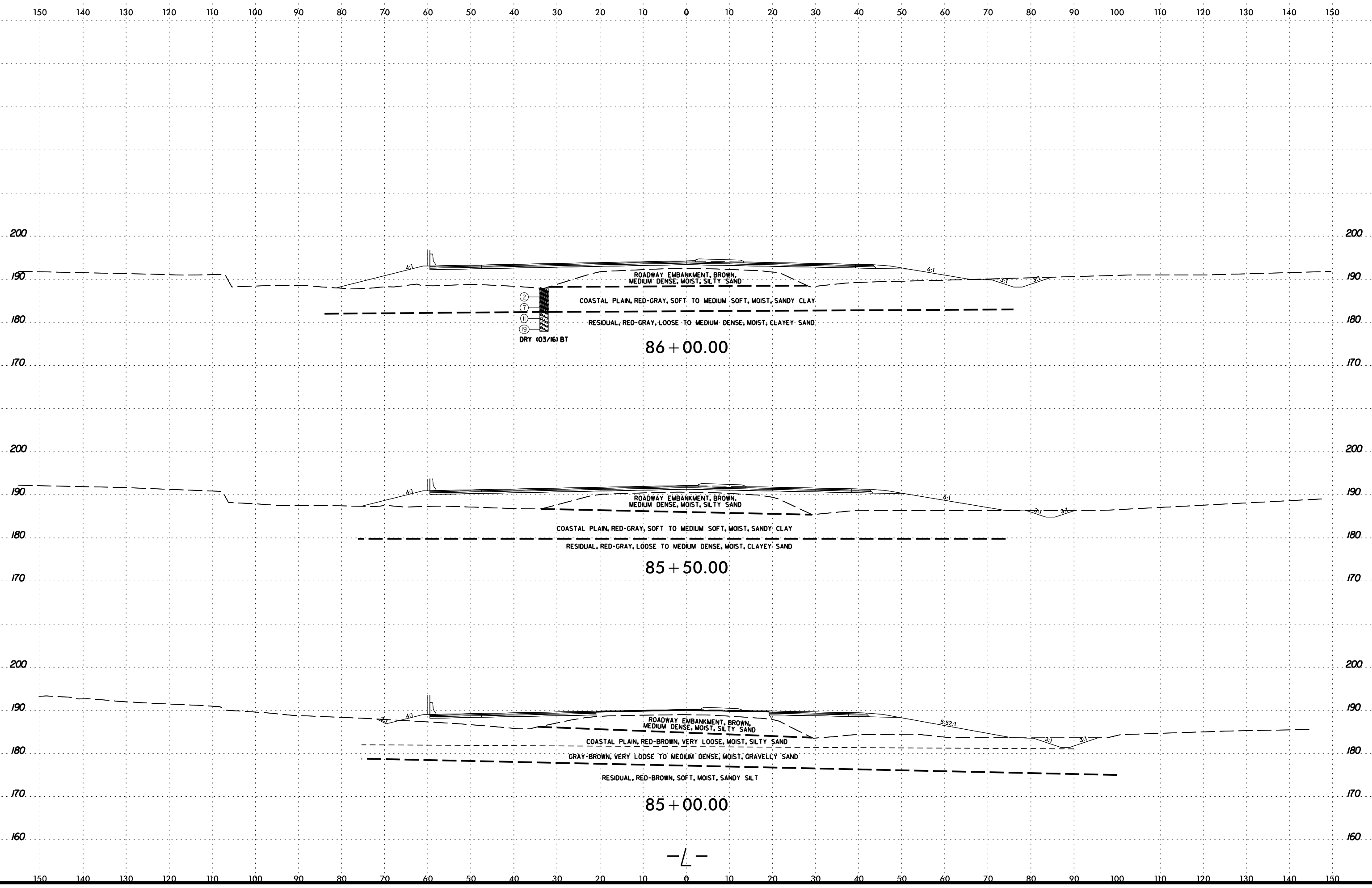

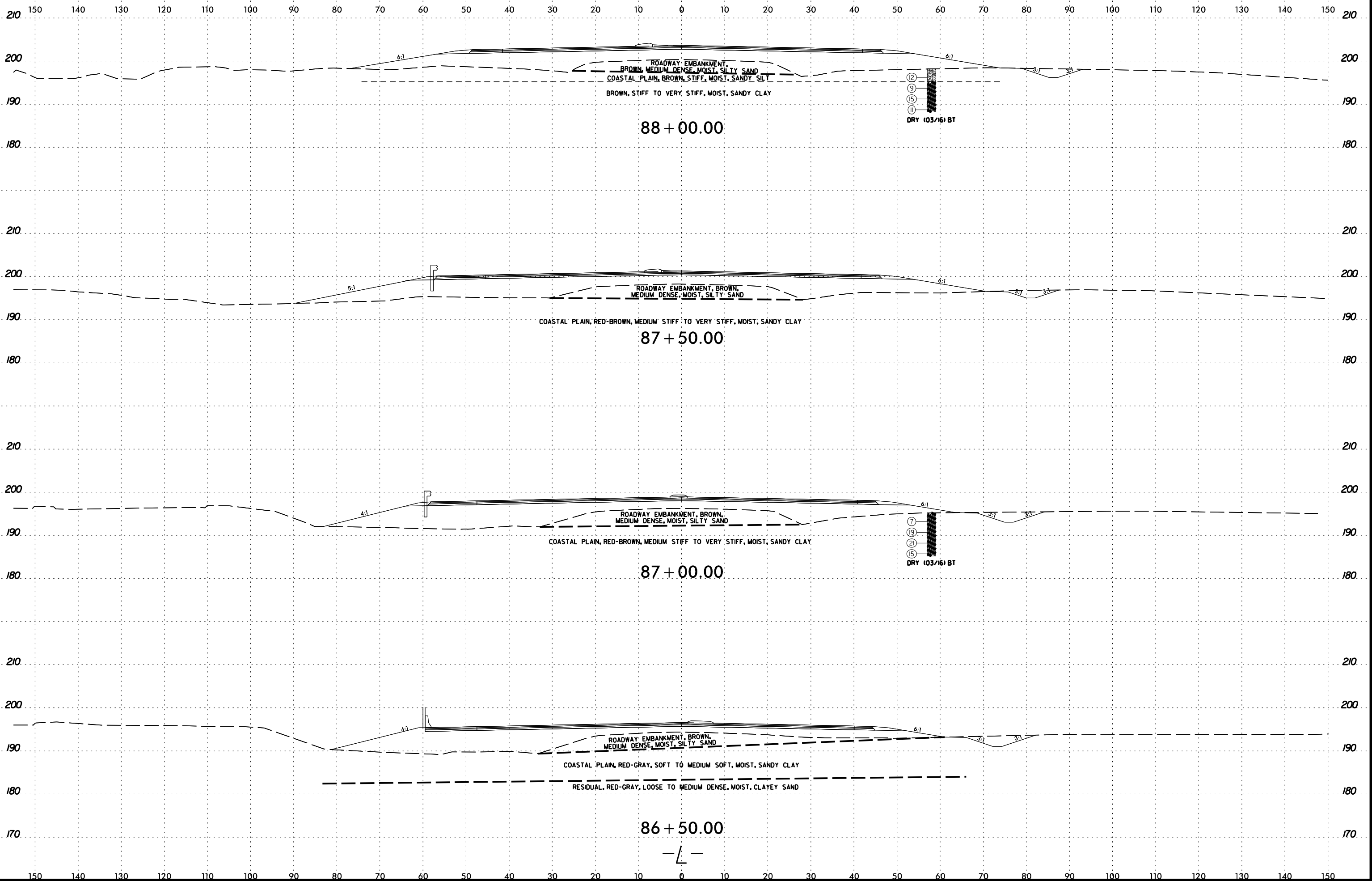

6/23/16

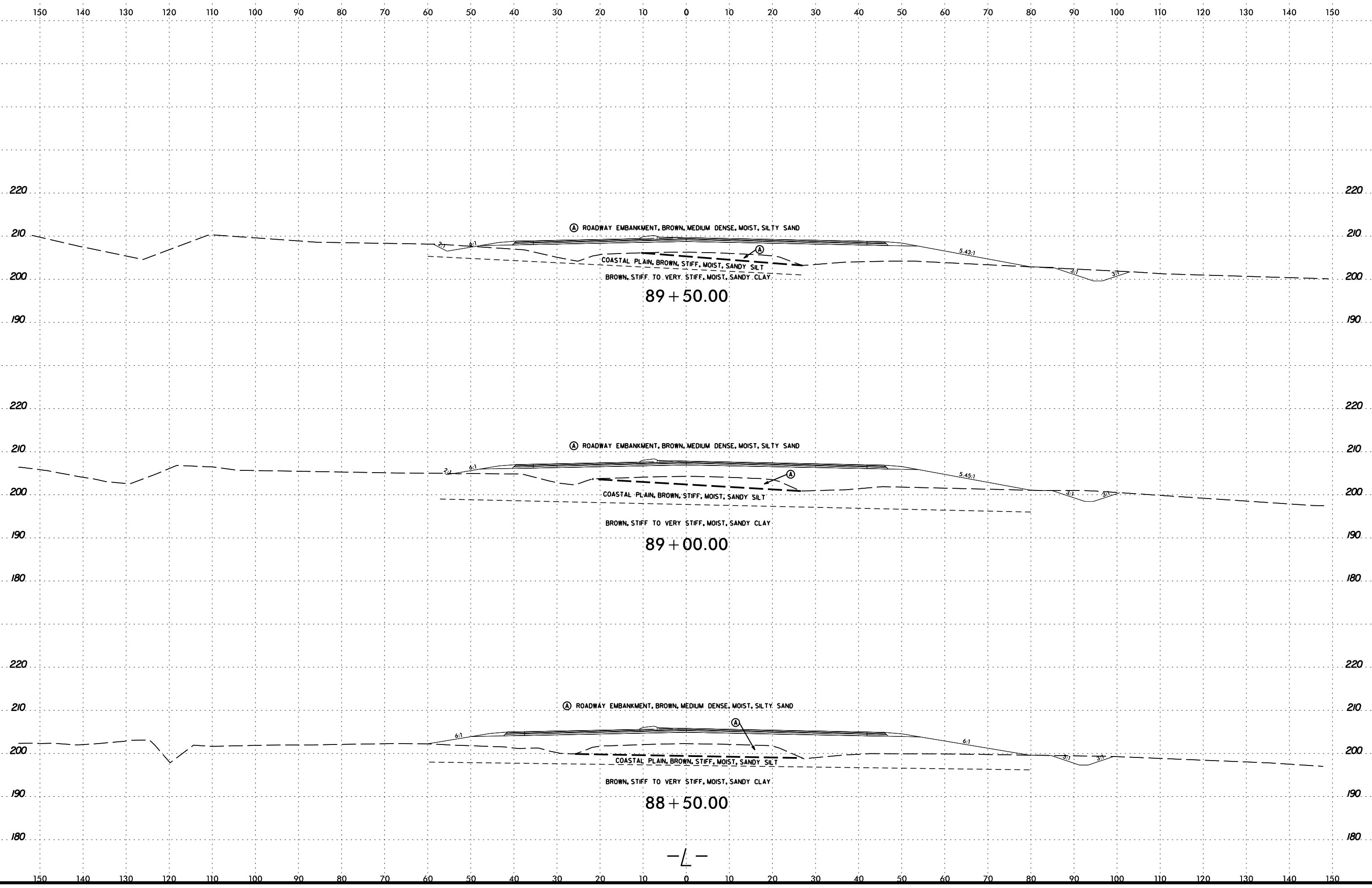

2/23/2017  
C:\Users\mcc01\OneDrive\Documents\R-3825B\RDWY.mxd\ref\CA00.GEOTECH\sc\R3825B\_Geo\_xsi.1.166+50-257+70.dgn

6/23/16

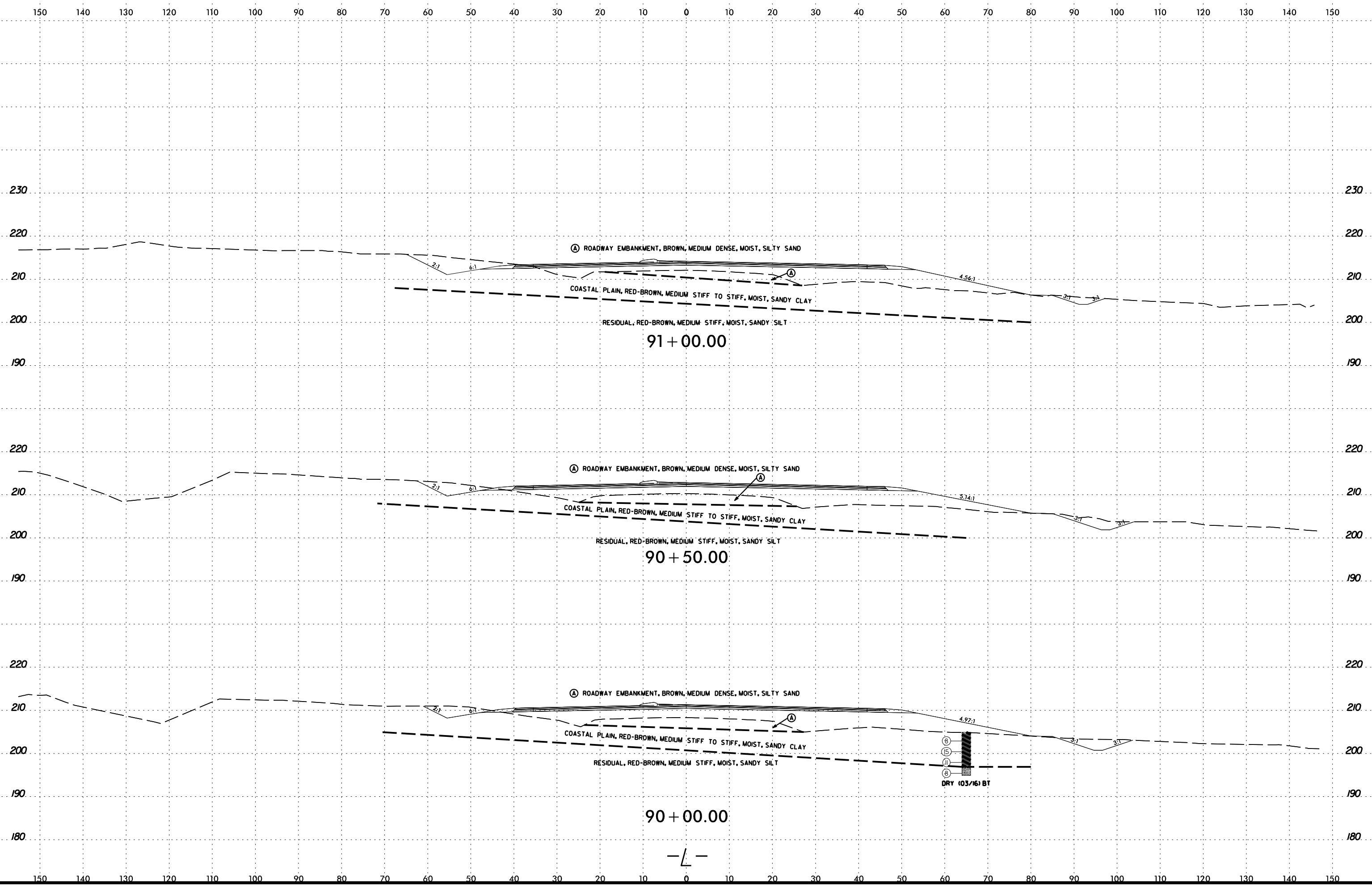

2/23/2017  
C:\Users\mcc01\OneDrive\Documents\R-3825B\GEO\RDWY.mxd\ref\CA00.GEOTECH\sc\R3825B\_Geo\_xsi.1.166+50+257+70.dgn

6/23/16

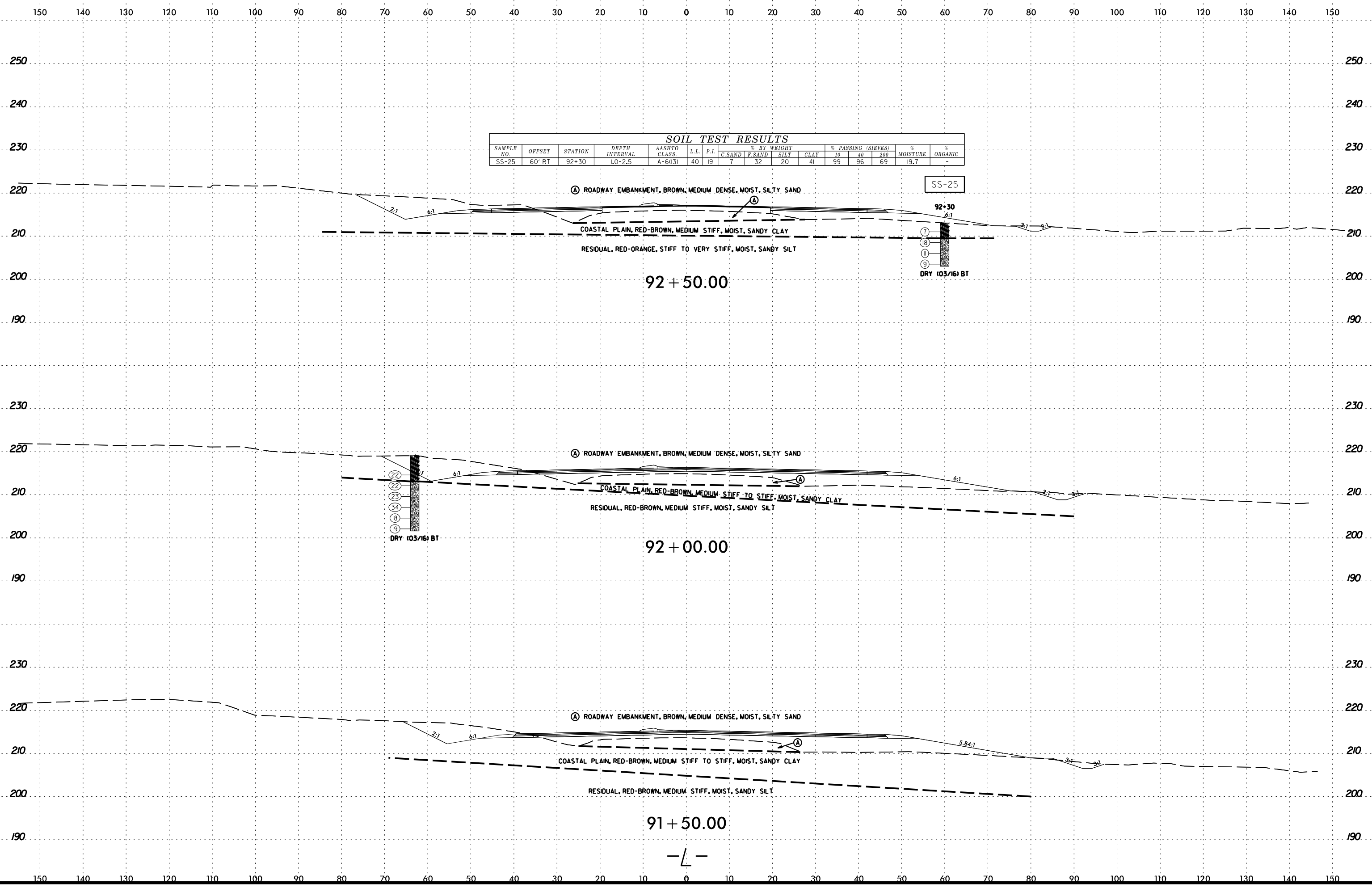

SAMPLE NO.	OFFSET	STATION	DEPTH INTERVAL	AASHTO CLASS.	L.L.	P.I.	% BY WEIGHT				% PASSING (SIEVES)			% MOISTURE	% ORGANIC
							C SAND	F SAND	SILT	CLAY	10	40	200		
SS-25	60' RT	92+30	1.0-2.5	A-6(03)	40	19	7	32	20	41	99	96	69	19.7	-

2/23/2017  
 M:\N\NCD01\R-3825B\R-3825B.GEO.RDWY.mxd  
 C:\Users\imington

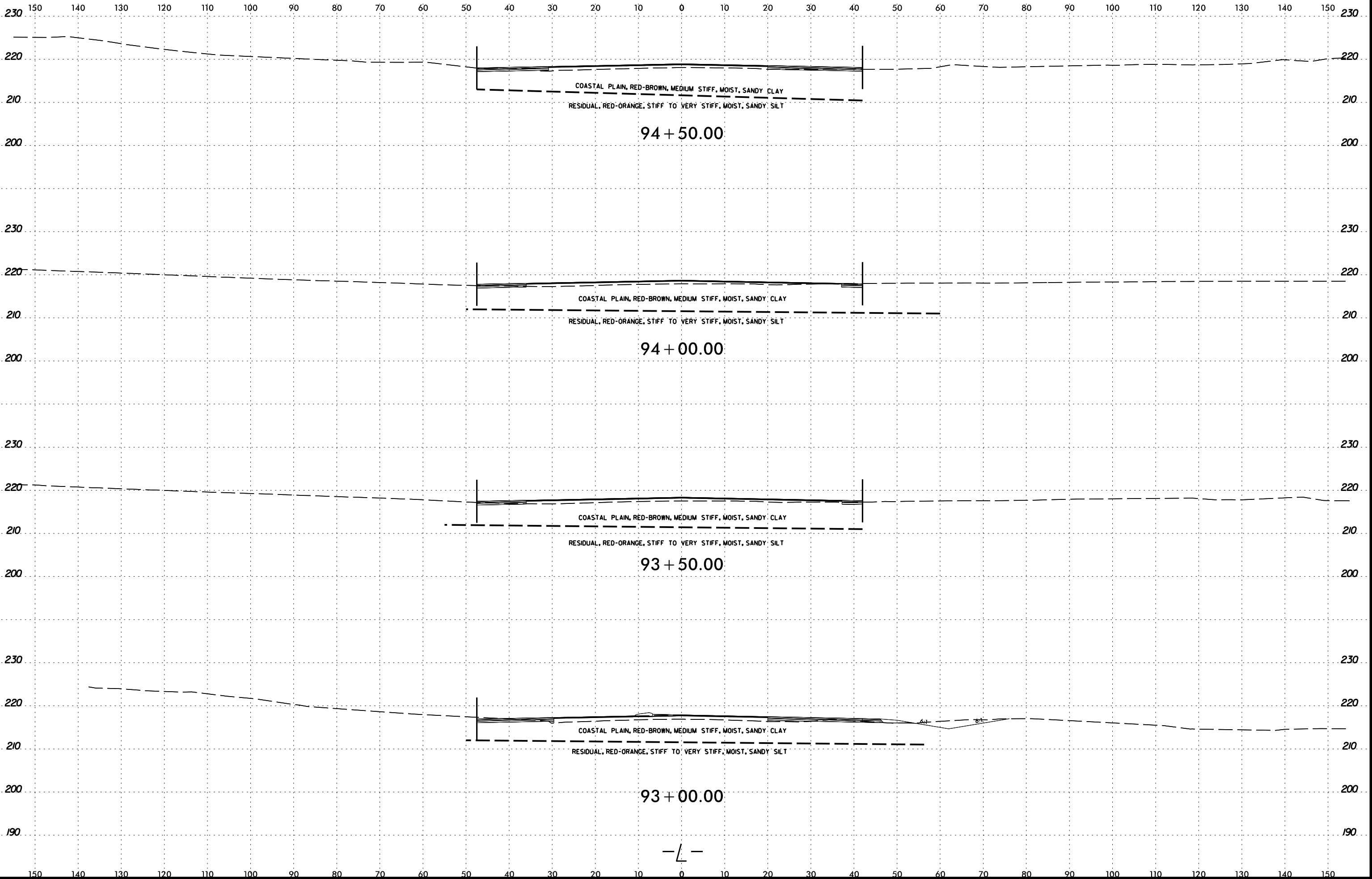

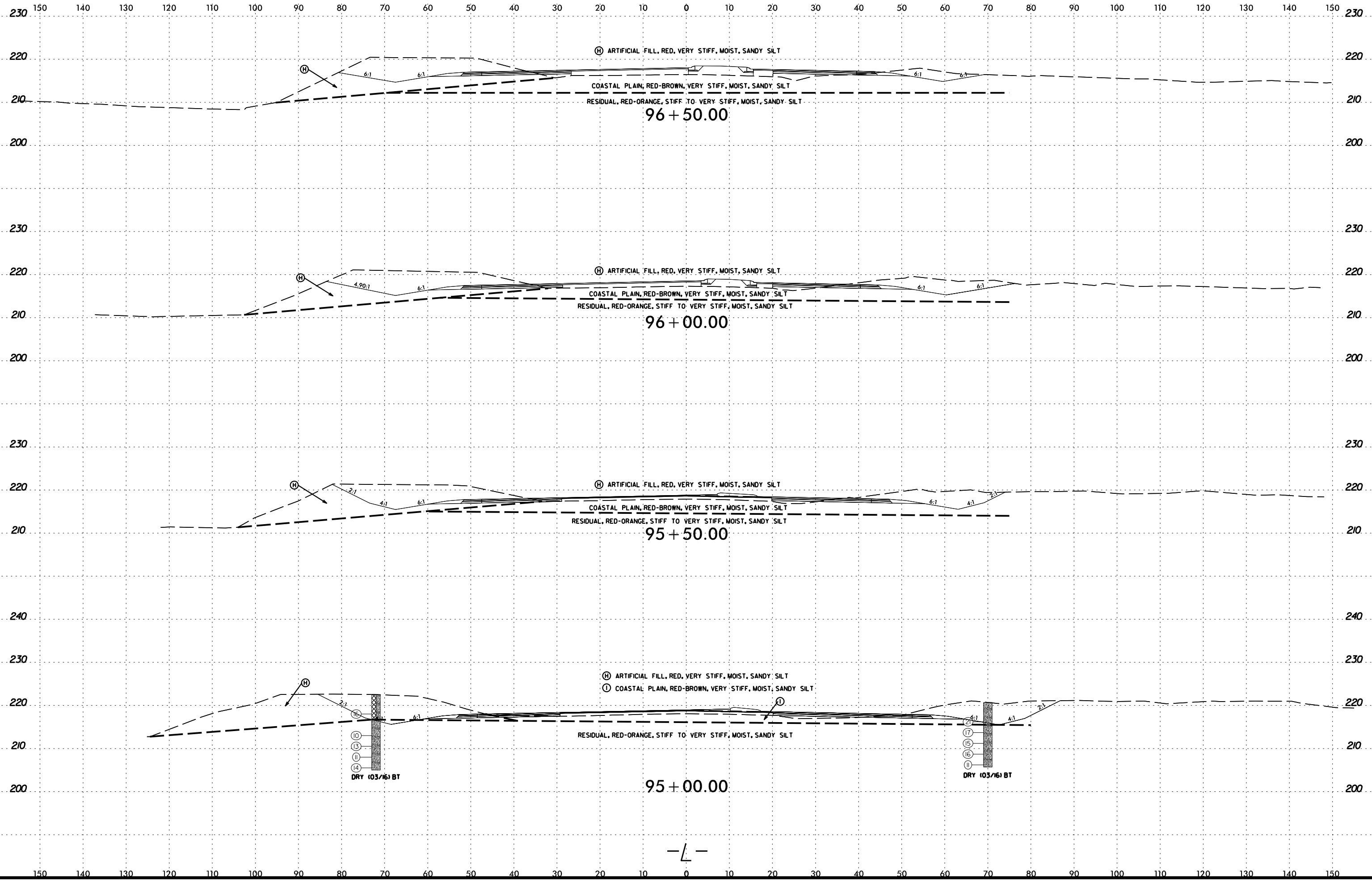

6/23/16

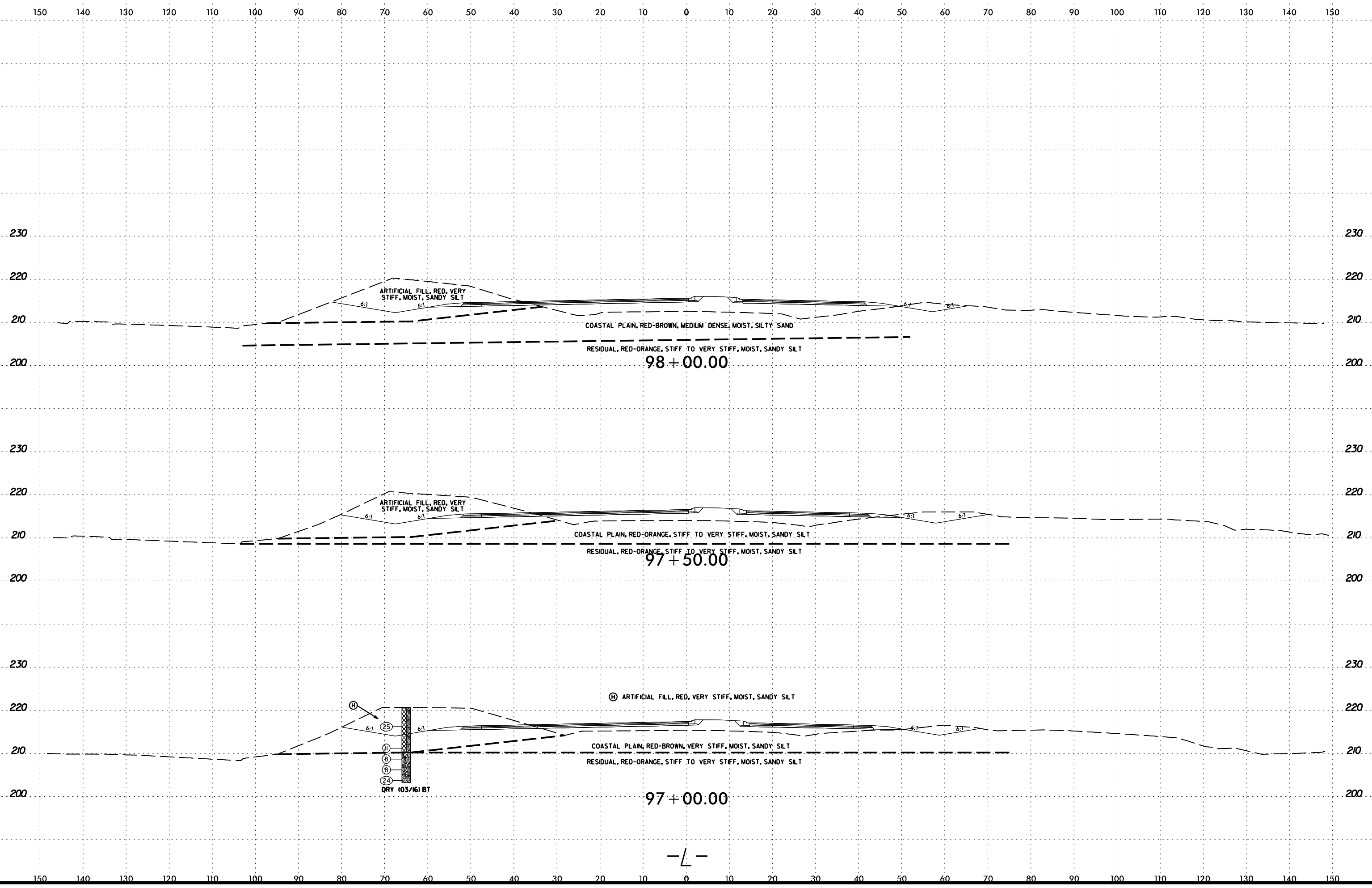

2/23/2017  
C:\Users\mcc01\OneDrive\Documents\R-3825B\Geo\RDWY\modif\ter\CA00\_GEO1TECH\sc\R3825B\_Geo\_xsi.1\66+50+257+70.dgn



6/23/16

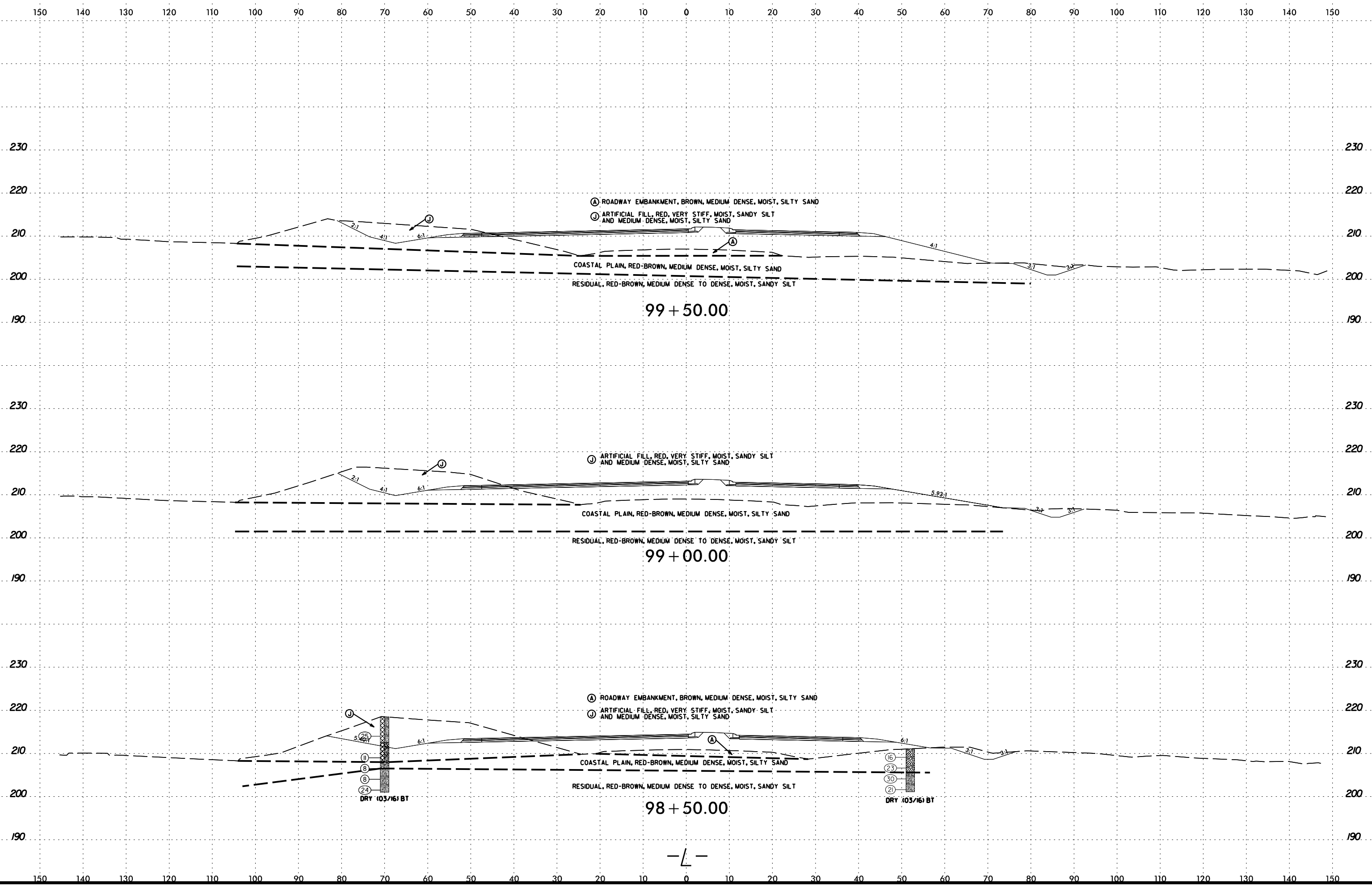

2/23/2017 2:51:00 PM C:\Users\mcc01\OneDrive\Documents\Projects\3825B\GEO\RDWY.mxd\ref\CA00.GEOTECH\3825B\_Geo\_xsi.1.166+50+257+70.dgn

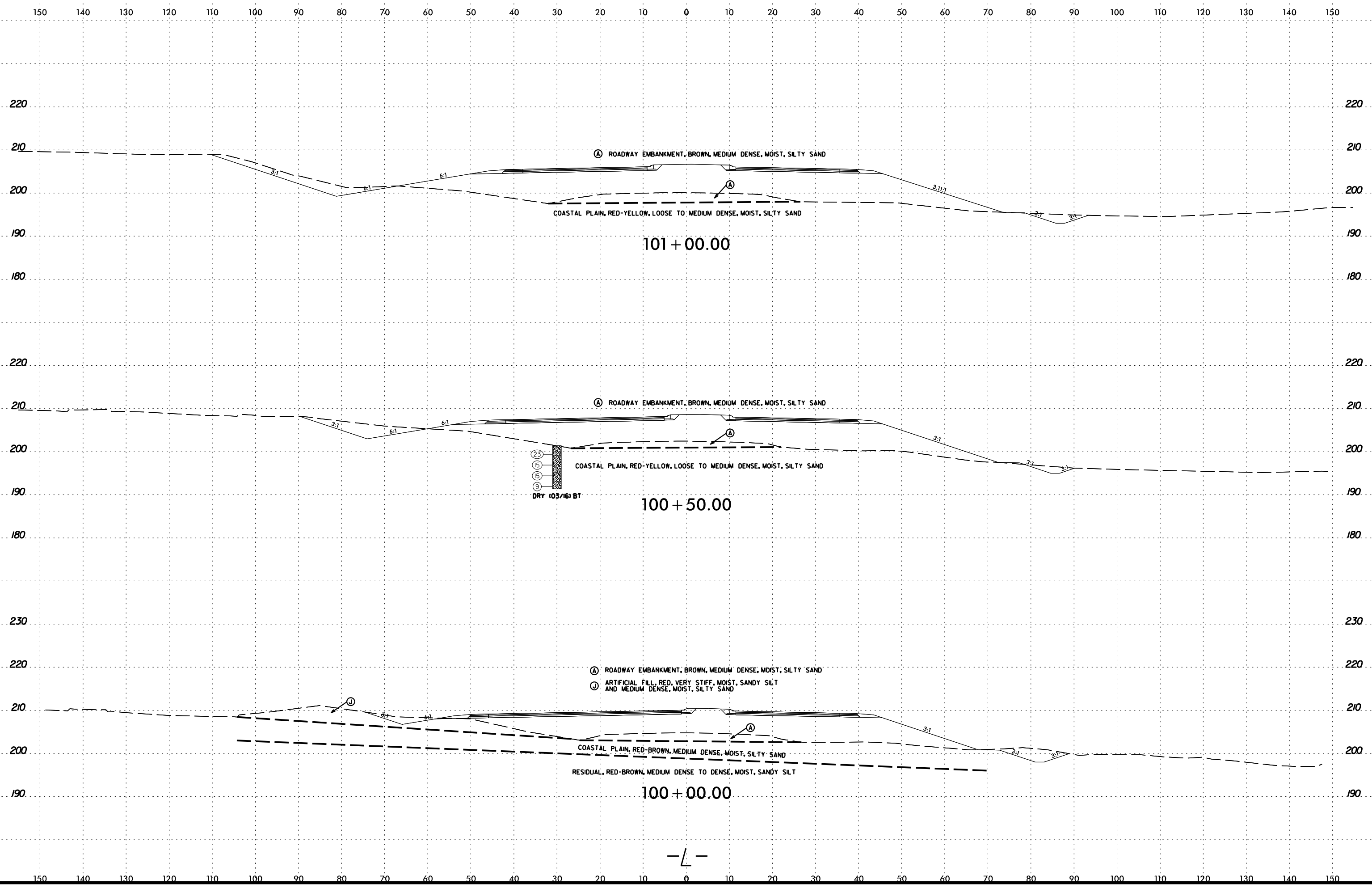

2/23/2017  
 M:\N\NCD01\R-3825B\R-3825B.GEO\_RDWY.mxd  
 C:\Users\imington

6/23/16

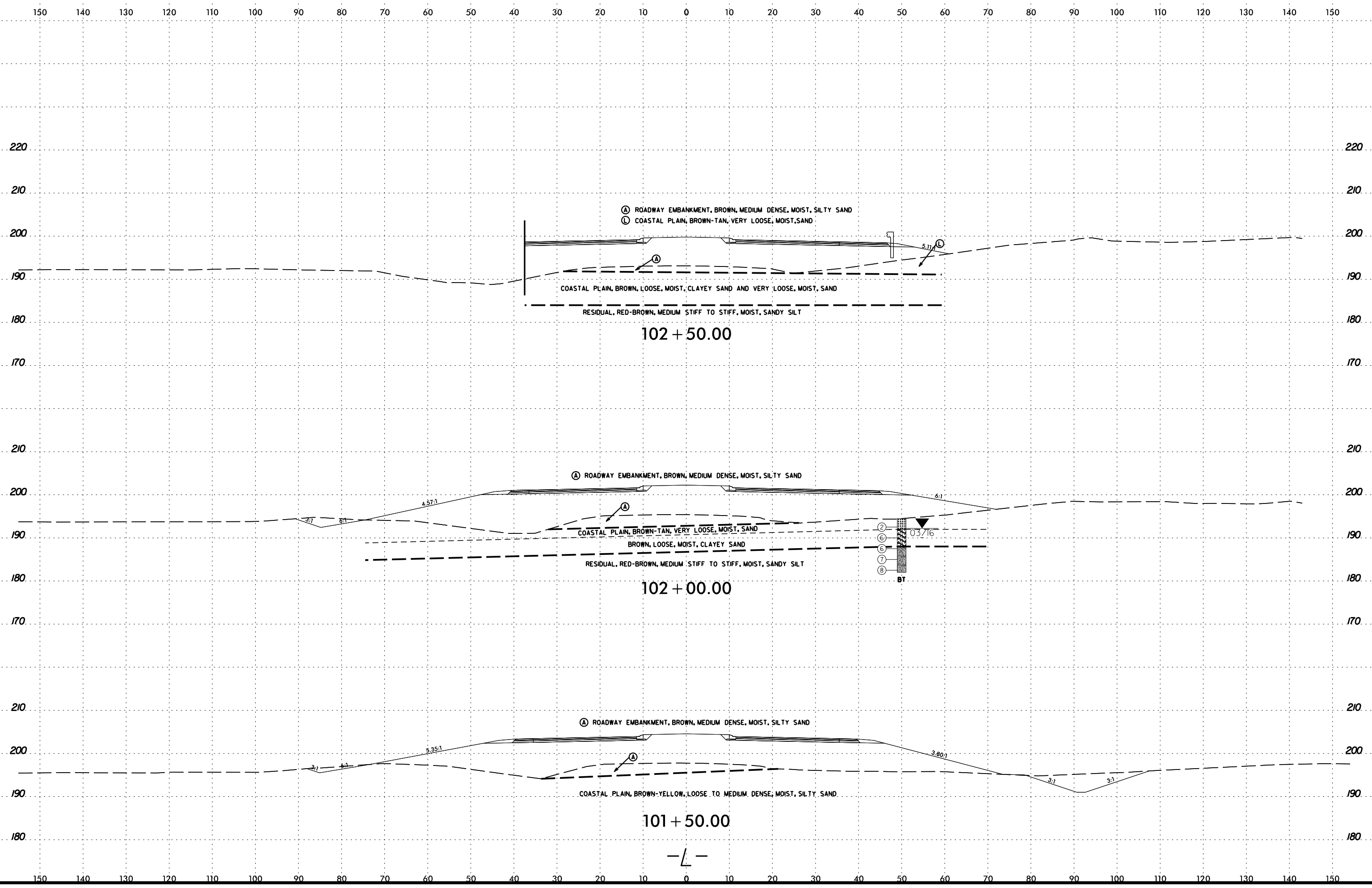

2/23/2017 11:58:00 AM C:\Users\mcc0101\OneDrive\Documents\R-3825B\GEO\RDWY.mxd\ref\CA00D.GEOTECH\sc\R3825B\_Geo\_xsl.1.166+50-257+70.dgn





6/23/16

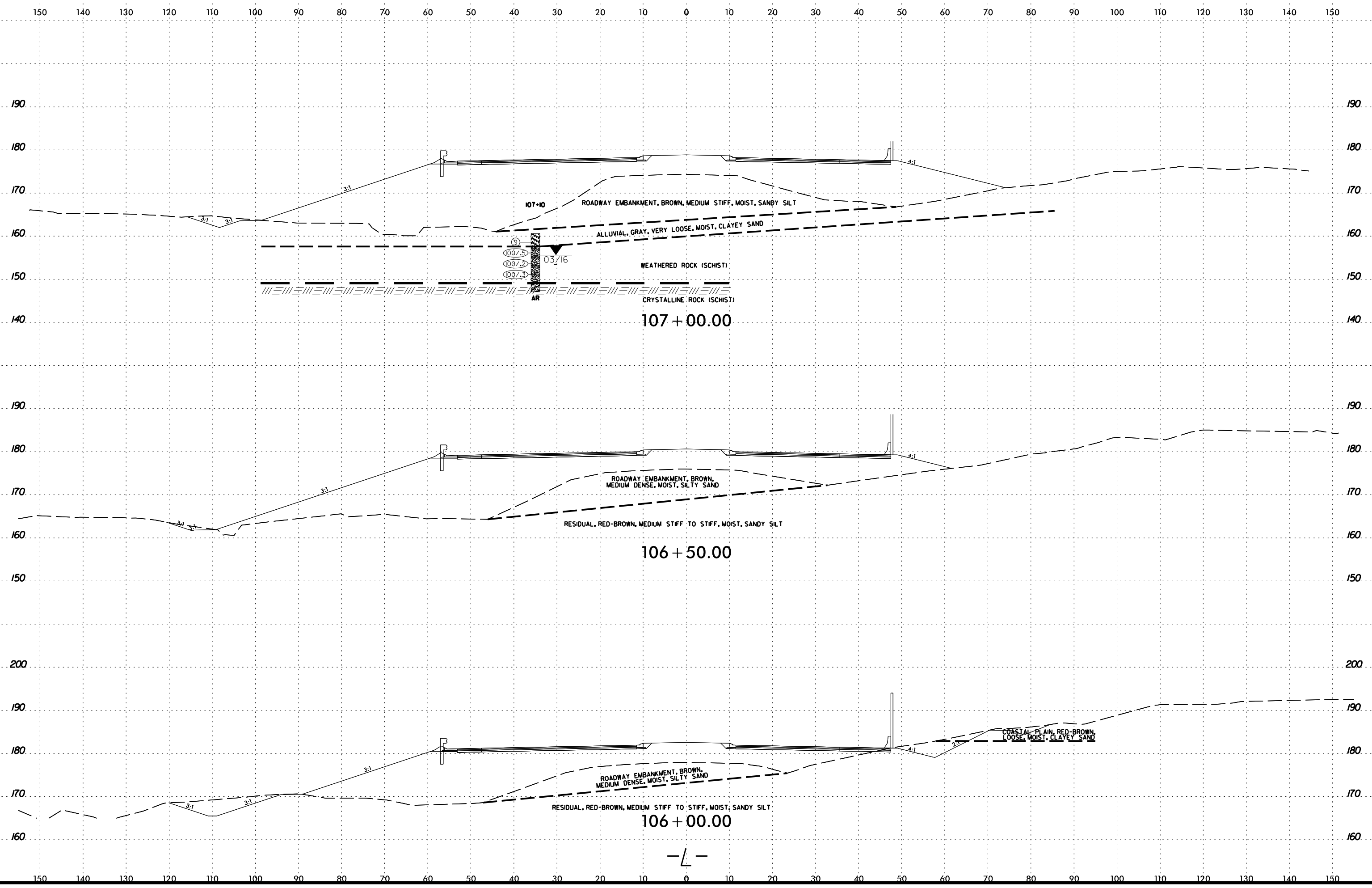

2/23/2017 11:58:00 AM C:\Users\lmgton\OneDrive\Documents\2017\Projects\3825B\RDWY\modif\ter\CA00D\_GEO\TECH\sc\R3825B\_Geo\_xsi.1.166+50+257+70.dgn



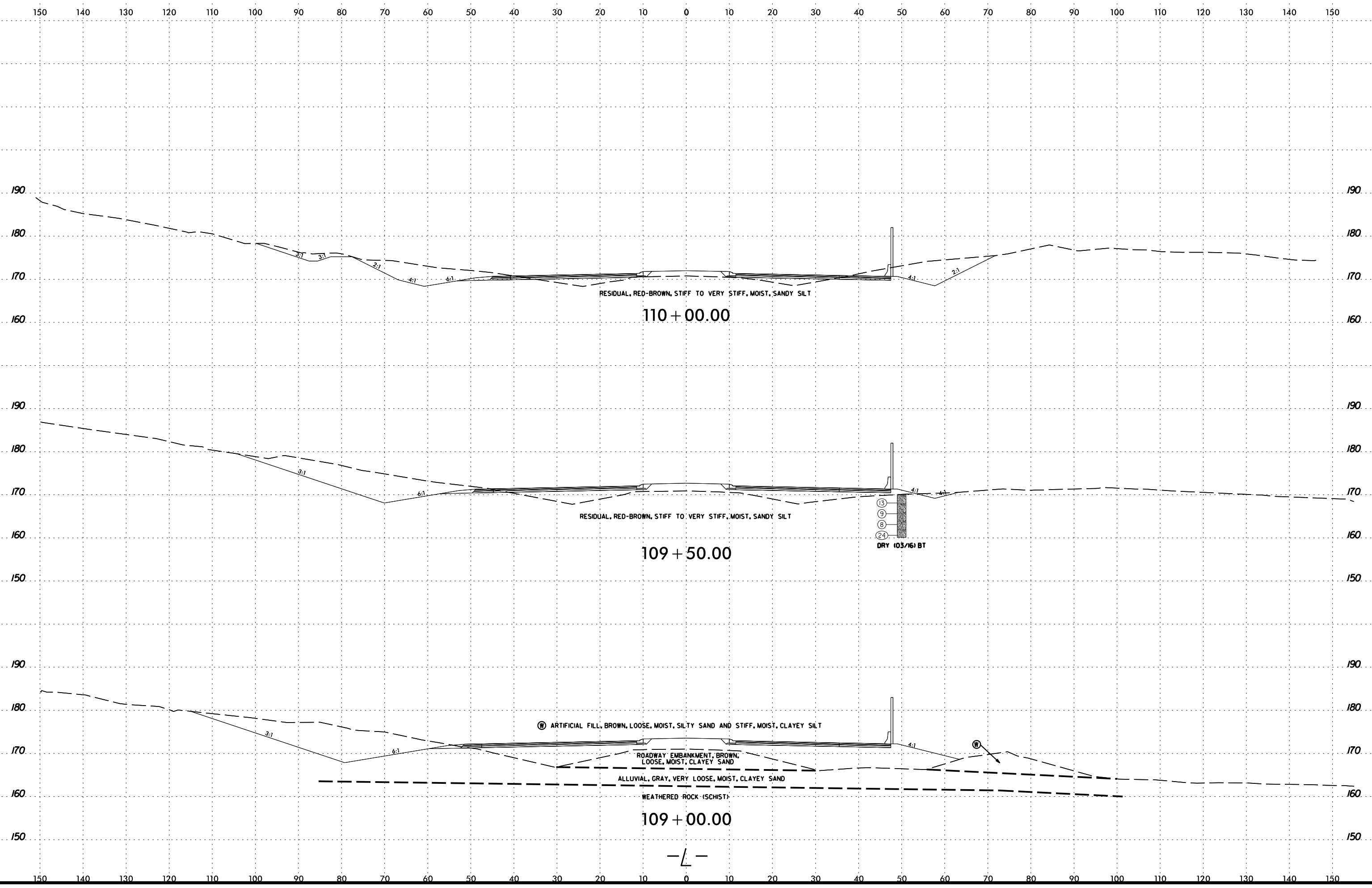

2/23/2017  
 C:\Users\mcc01\OneDrive\Documents\Projects\3825B\GEO\RDWY\modif\ter\CA00D\_GEO\TECH\asc\R3825B\_Geo\_xsi.1.166+50-257+70.dgn  
 M:\N\CD01\R-3825B\R-3825B.GEO.RDWY



6/23/16

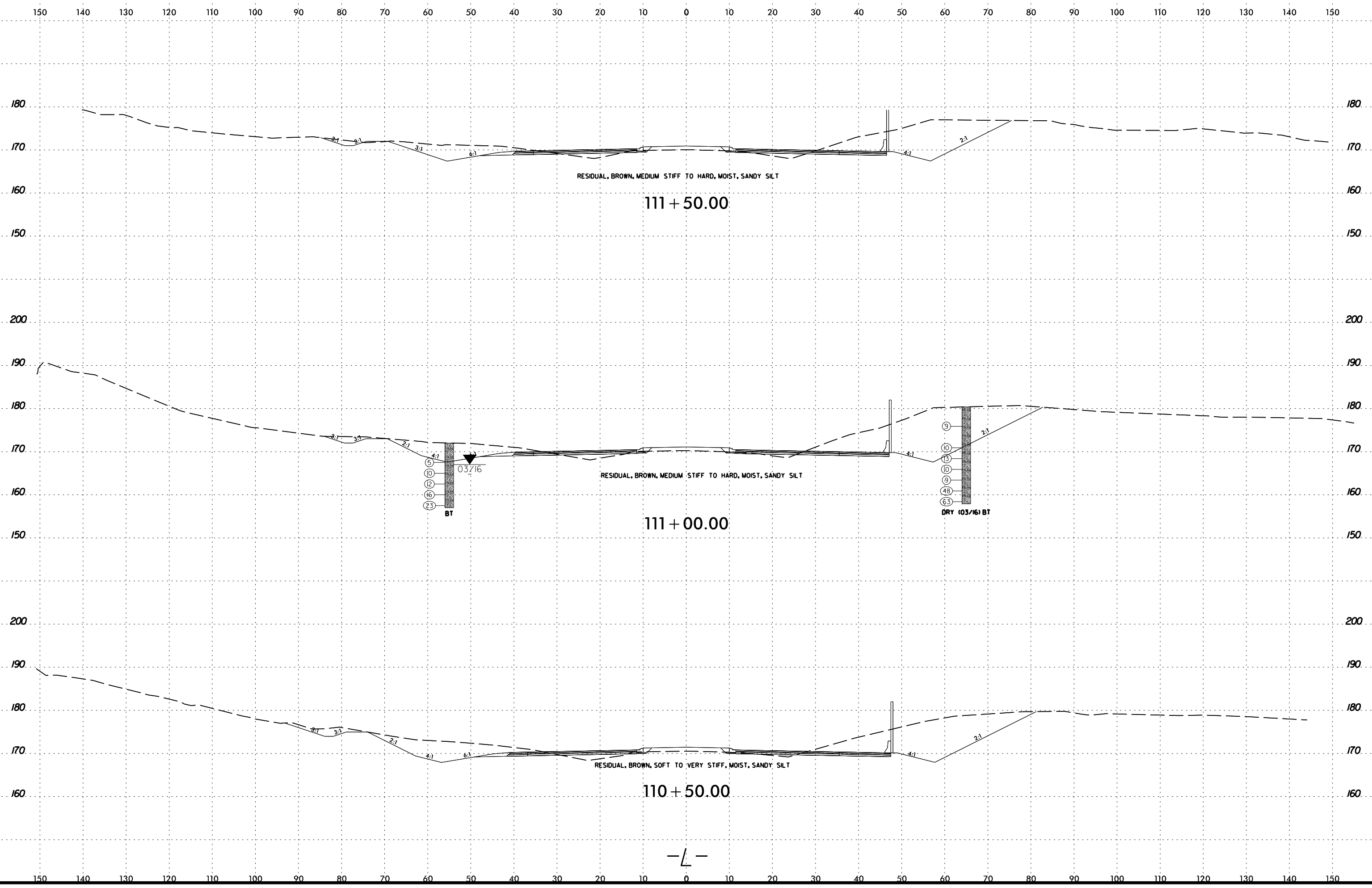

2/23/2017  
 M:\N\CD01\R-3825B\R-3825B.GEO.RDWY.mxd  
 C:\ur\ington

6/23/16

SOIL TEST RESULTS															
SAMPLE NO.	OFFSET	STATION	DEPTH INTERVAL	AASHTO CLASS.	L.L.	P.I.	% BY WEIGHT				% PASSING (SIEVES)			% MOISTURE	% ORGANIC
							C. SAND	F. SAND	SILT	CLAY	10	40	200		
SS-26	55' LT	113+00	3.5-5.0	A-7-6(16)	43	14	12	32	36	20	99	92	65	28.1	-

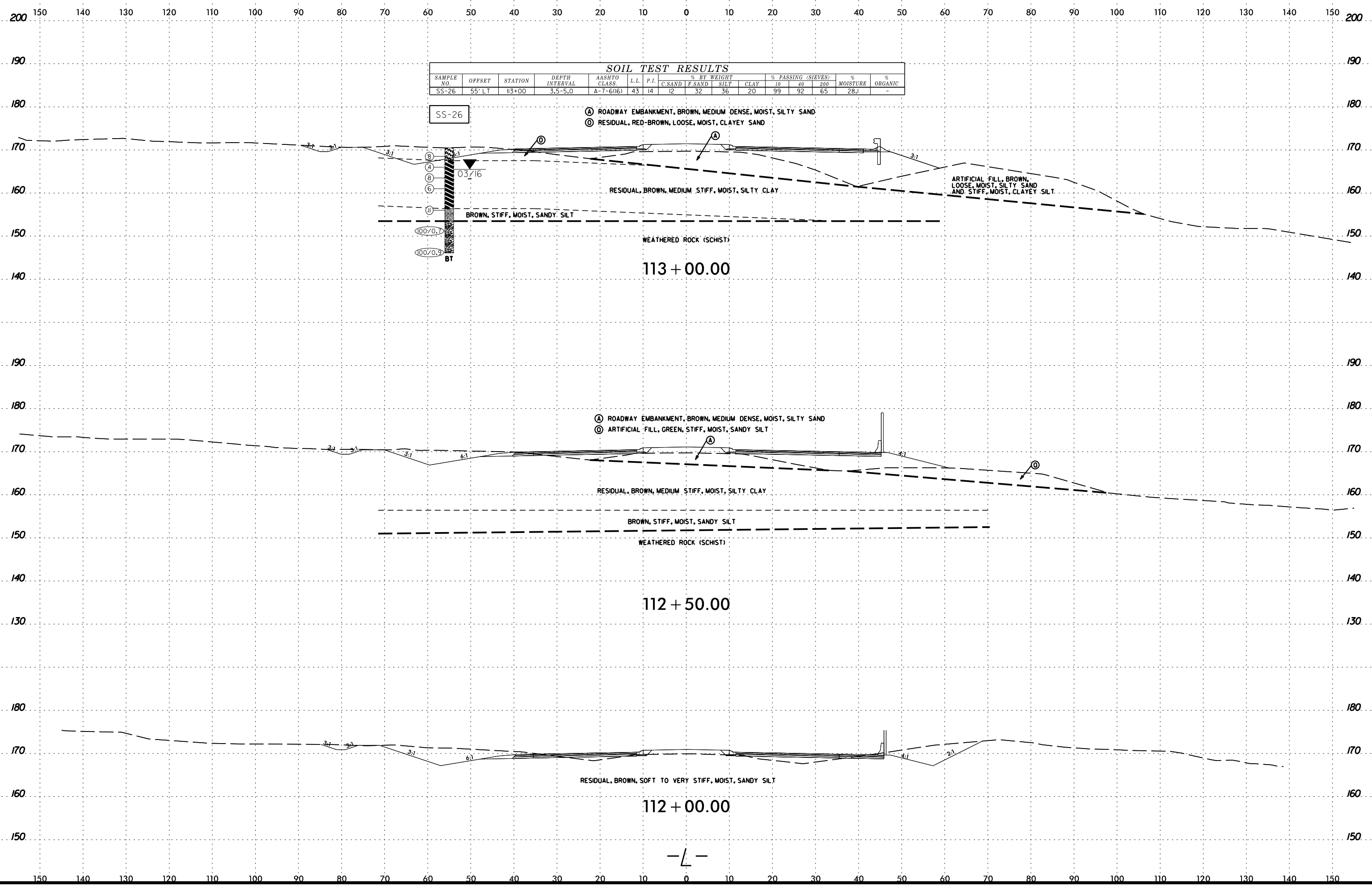

2/23/2017 11:50:00 AM C:\Users\mcc01\OneDrive\Documents\11666+50-257+70.dgn

6/23/16

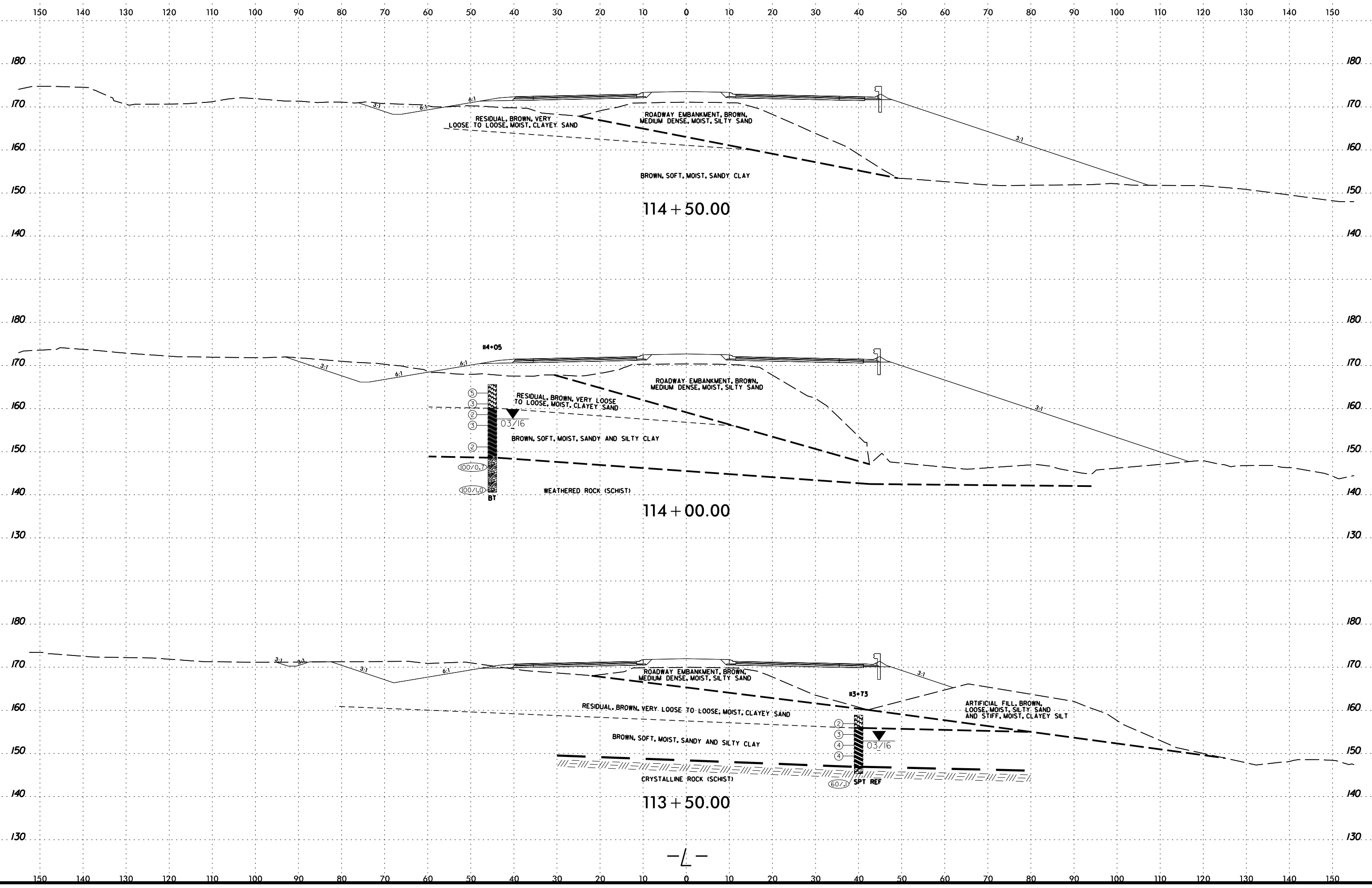

2/23/2017  
 M:\N\CD01\R-3825B\GEO\_RDWY.mxd  
 C:\Program Files\Autodesk\AutoCAD 2010\AutoCAD.exe  
 2/23/2017  
 M:\N\CD01\R-3825B\GEO\_RDWY.mxd  
 C:\Program Files\Autodesk\AutoCAD 2010\AutoCAD.exe





6/23/16

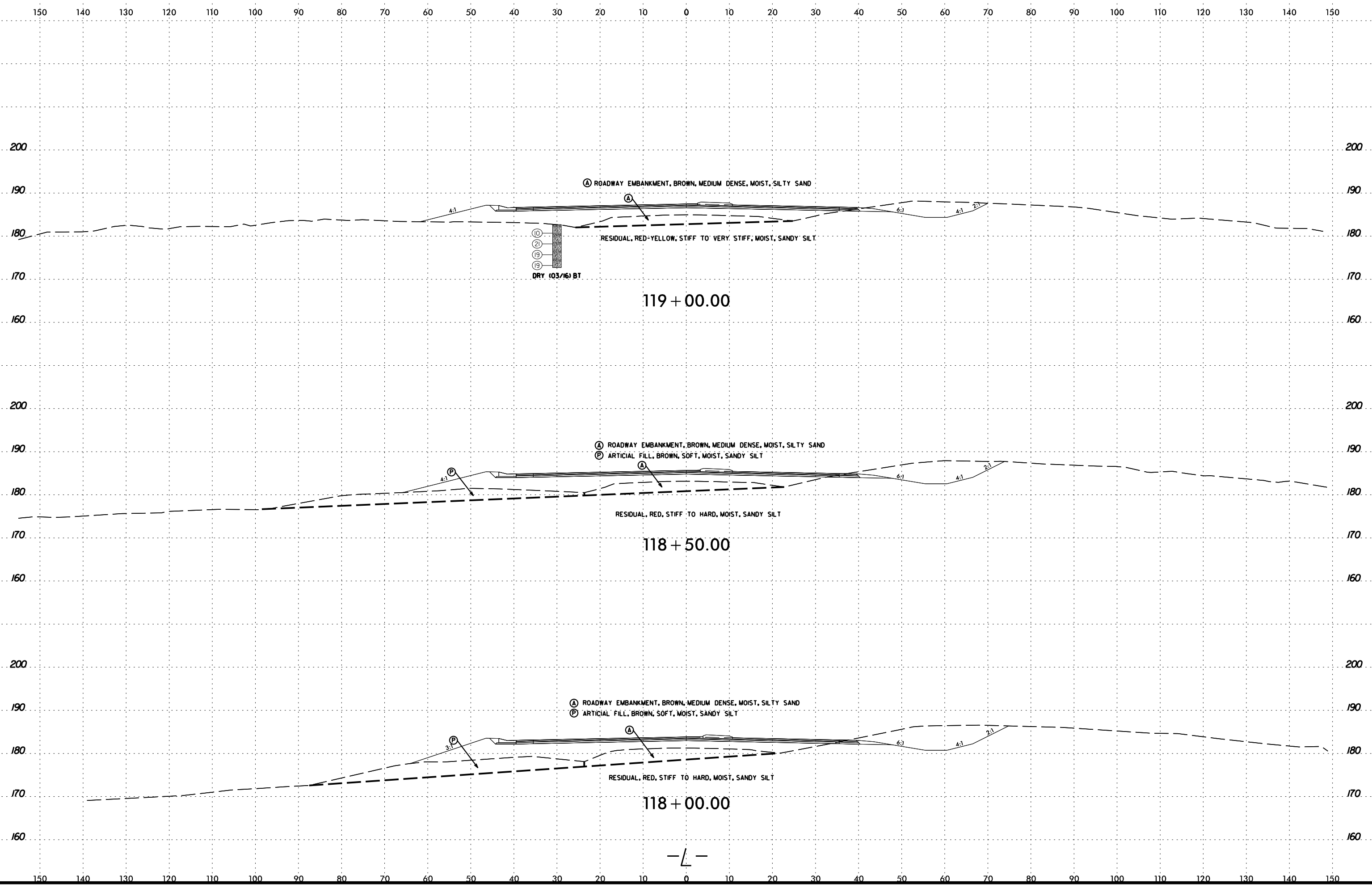

2/23/2017  
M:\N\CD01\R-3825B\R-3825B.GEO.RDWY.modifier\CA00.GEOTECH\sc\R3825B\_Geo\_xsi.1.166+50+257+70.dgn  
C:\ur\imgton

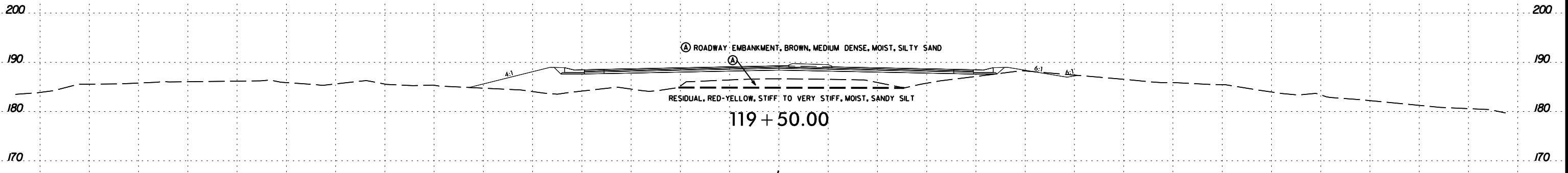
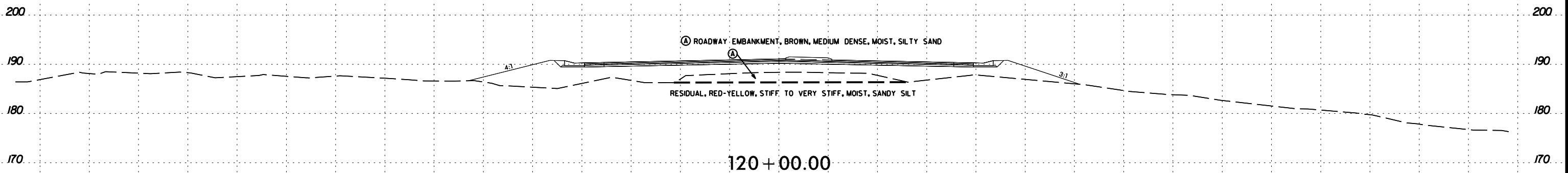
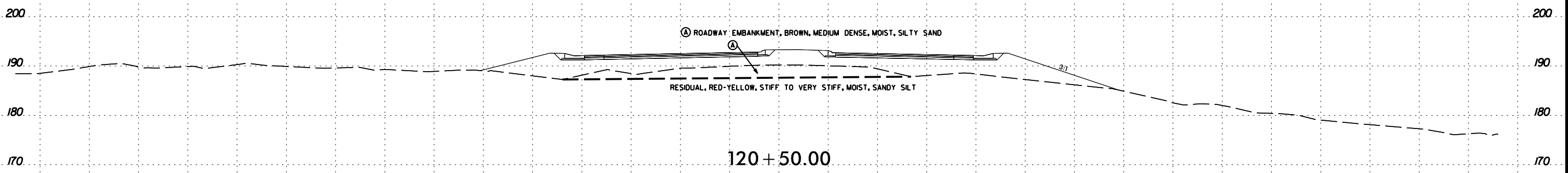
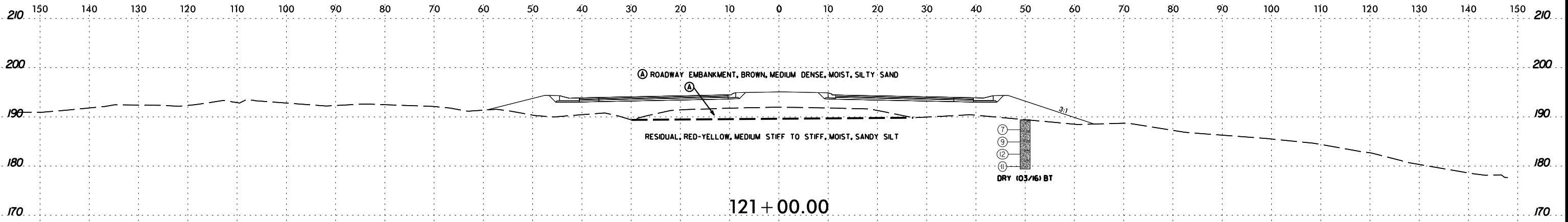

2/23/2017 11:58:00 AM C:\Users\mcc01\OneDrive\Documents\R-3825B\GEO\RDWY\modif\ter\CA00D\_GEO\TECH\sc\R3825B\_Geo\_xsi.1.166+50+257+70.dgn

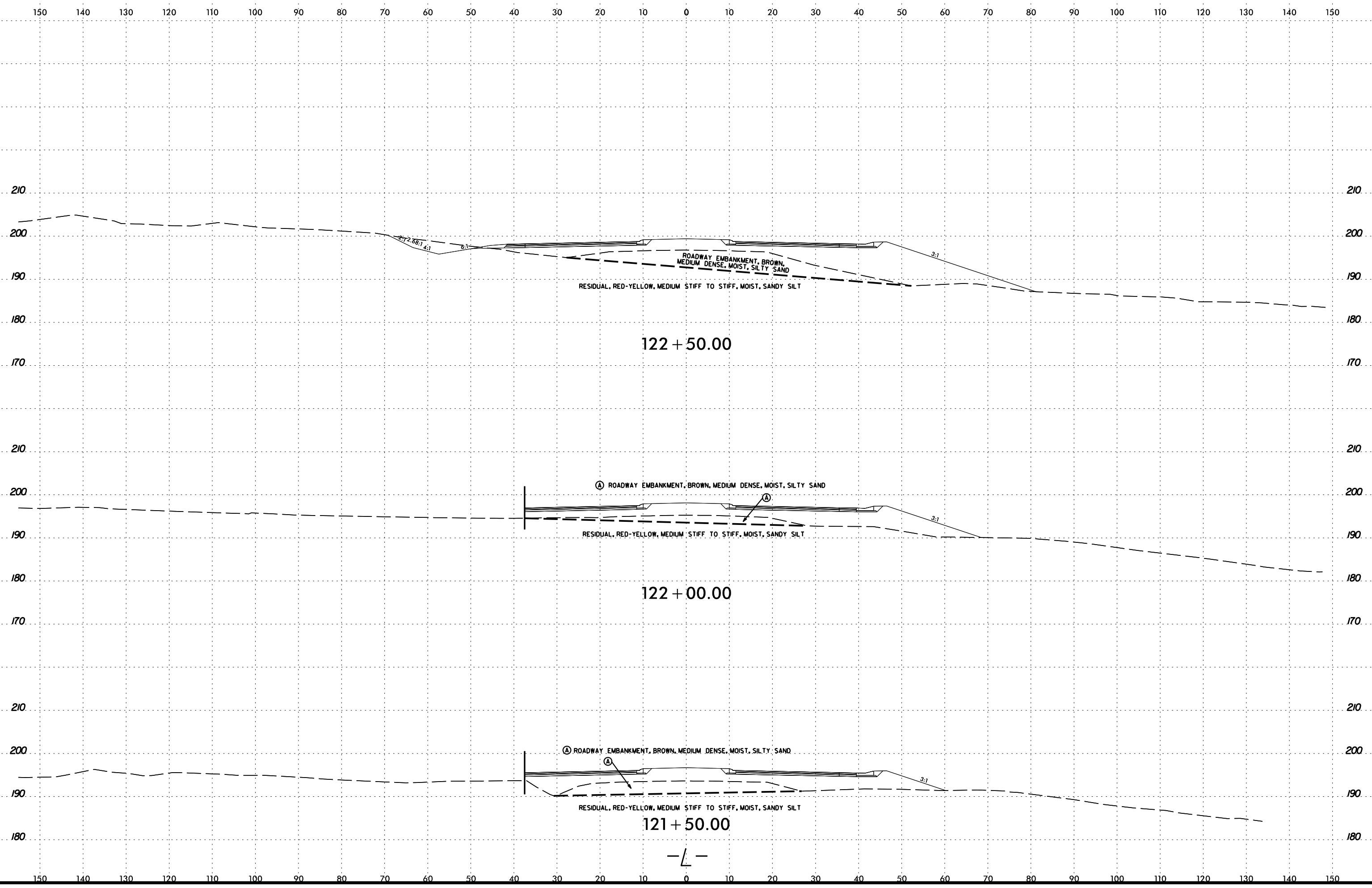









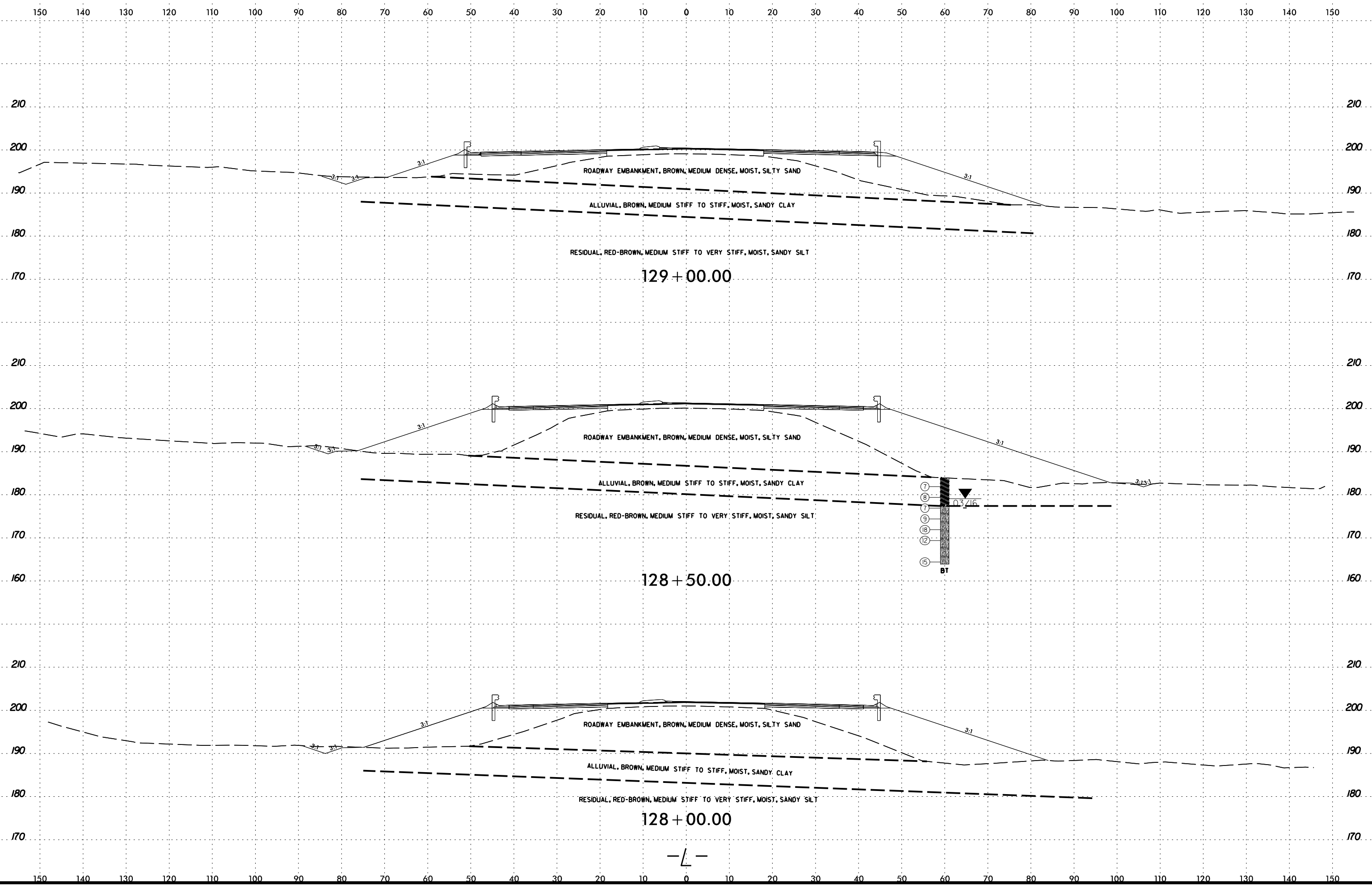



6/23/16

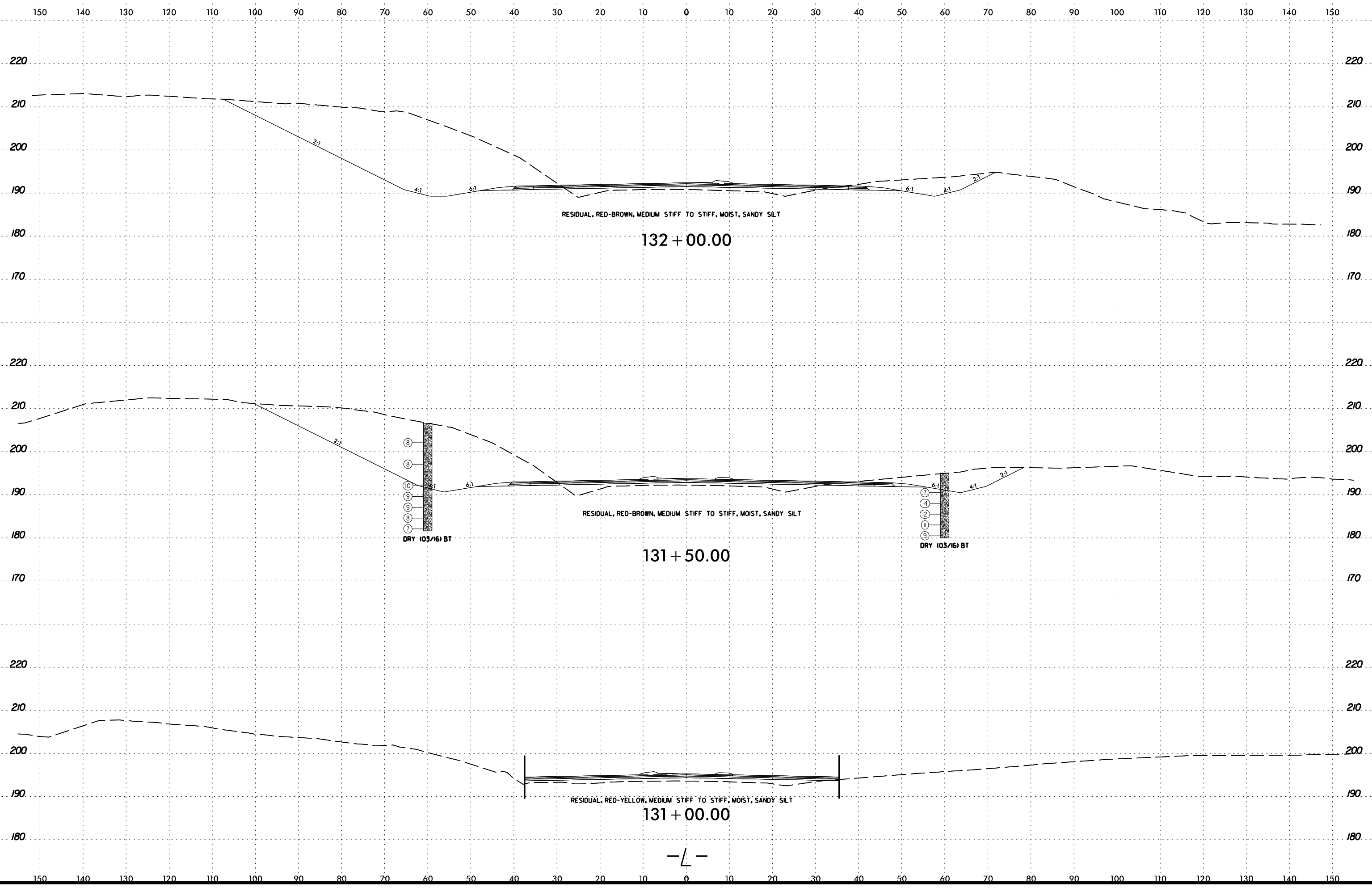

2/23/2017  
M:\N\NCD01\R-3825B\R-3825B.GEO...RDWY...modif\er\CA00D\_GEO\TECH\sc\R3825B\_Geo\_xsi.1.166+50+257+70.dgn  
C:\ur\ington

6/23/16

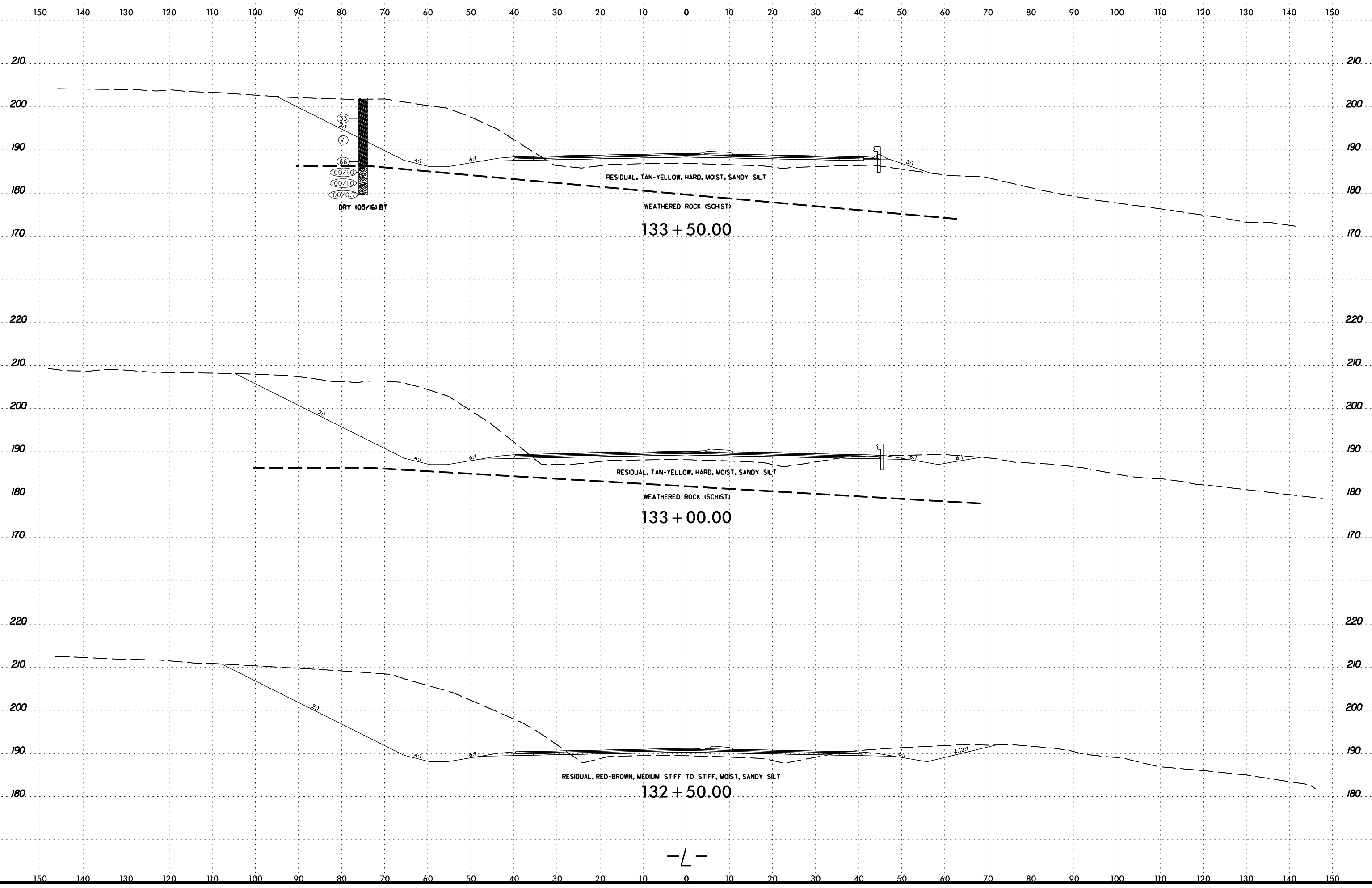

2/23/2017  
M:\N\NCD01\R-3825B\R-3825B.GEO.RDWY...modif\er\CA00.GEOTECH\sc\R3825B\_Geo\_xsi.1.166+50-257+70.dgn





6/23/16

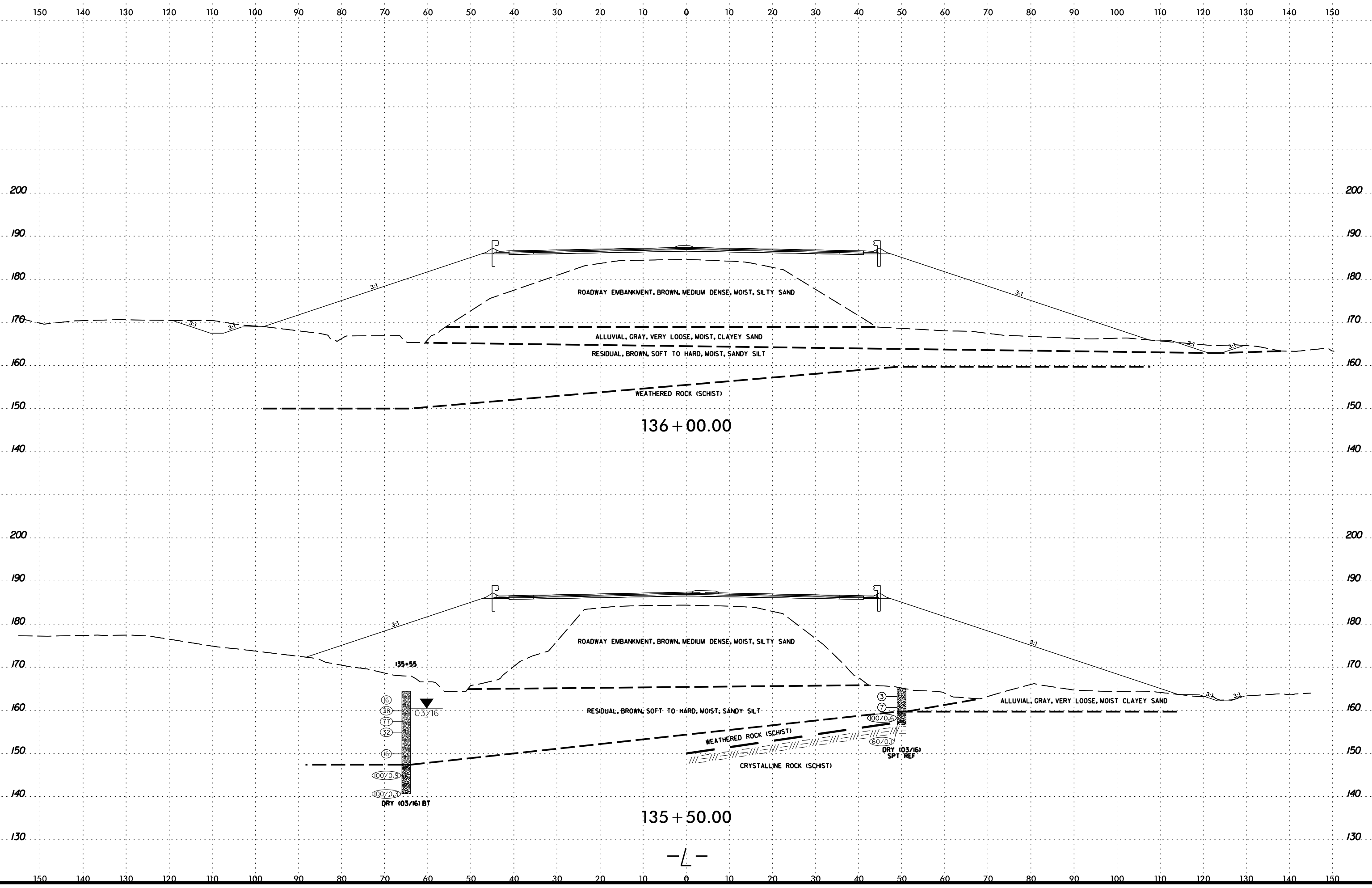

2/23/2017  
 C:\Users\mcc01\OneDrive\Documents\Projects\3825B\GEO\RDWY.mxd\ref\CA00D.GEOTECH\3825B\_Geo\_xsi.1.166+50-257+70.dgn  
 M:\N\CD01\R-3825B\R-3825B.GEO\RDWY.mxd\ref\CA00D.GEOTECH\3825B\_Geo\_xsi.1.166+50-257+70.dgn



6/23/16

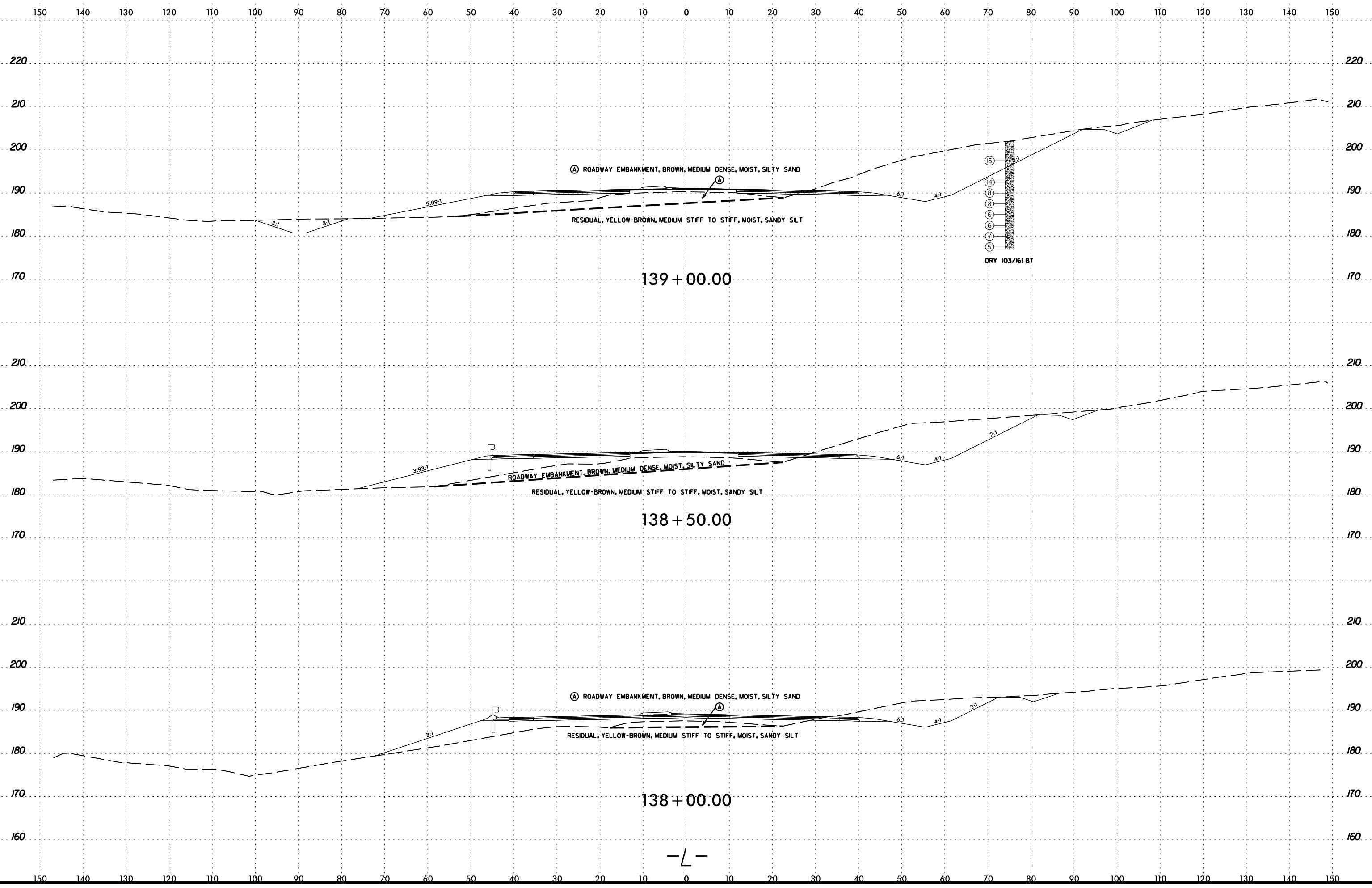

2/23/2017  
C:\Users\mcc01\OneDrive\Documents\R-3825B\RDWY.mxd\ref\CA00.GEOTECH\sc\R3825B\_Geo\_xsl.1.166+50-257+70.dgn



6/23/16  
2/23/2017  
C:\Users\mcc01\OneDrive\Documents\Projects\2017\20170223\20170223.dgn

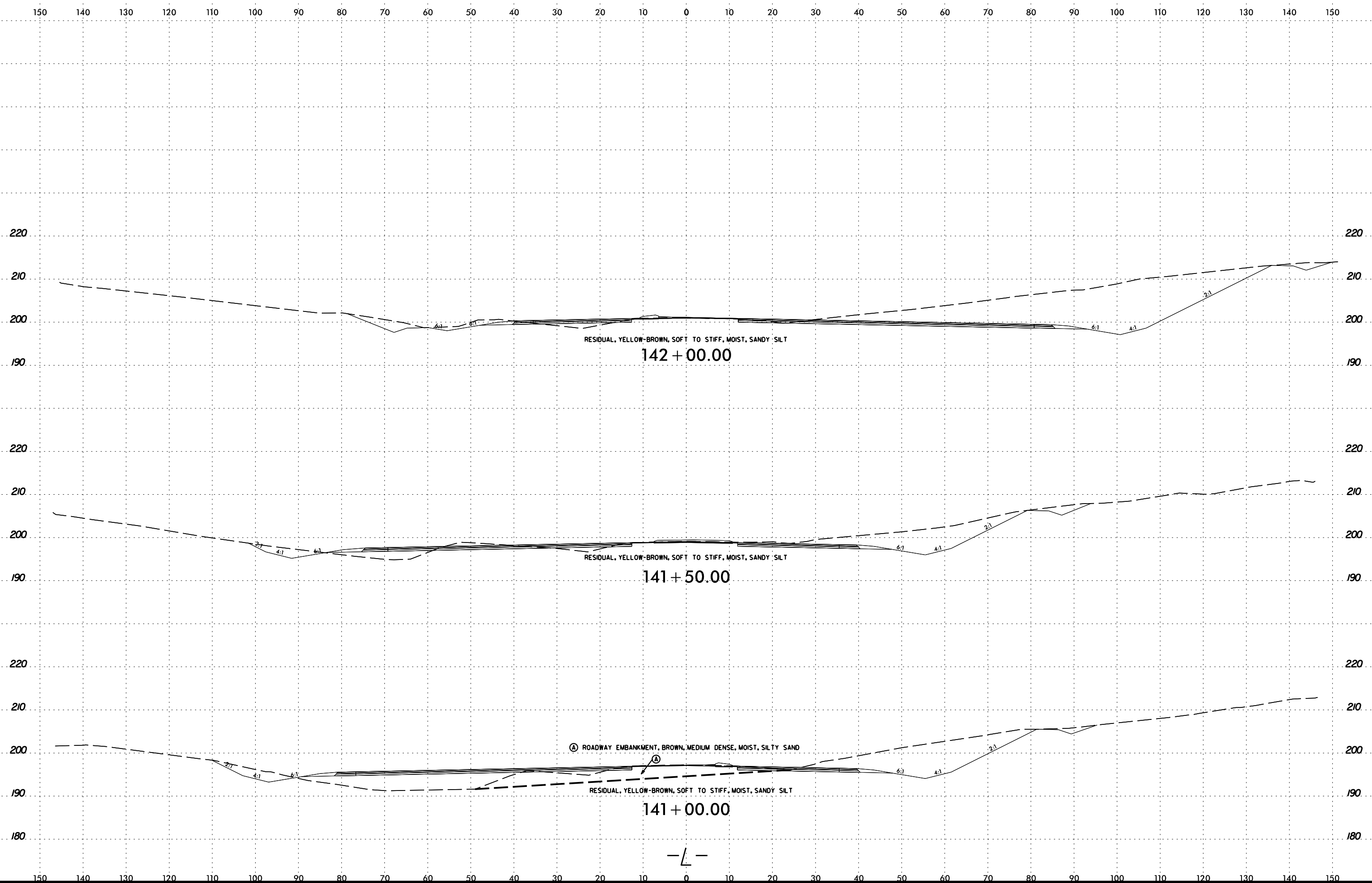

6/23/16

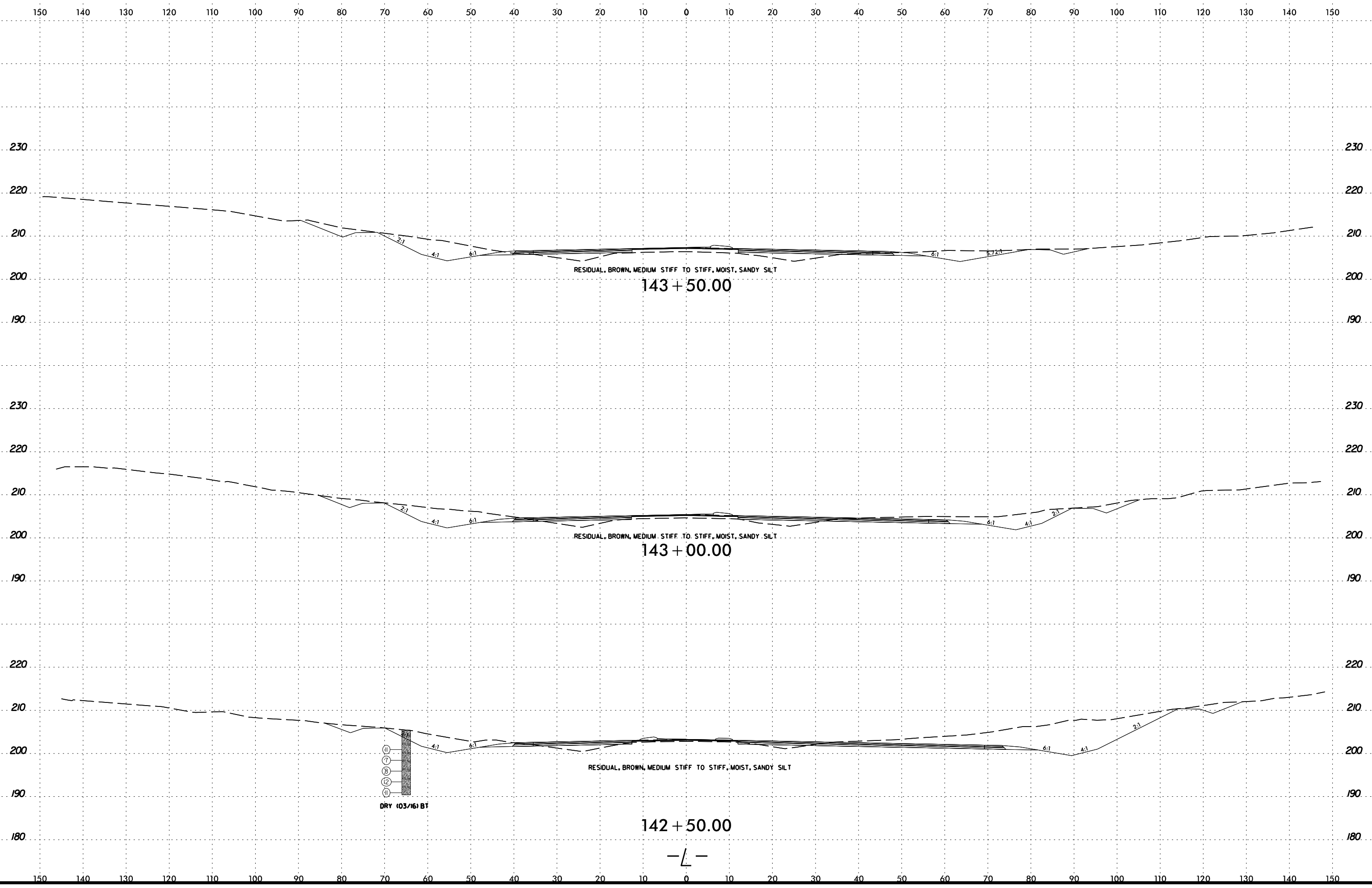

2/23/2017  
 C:\Users\mcc01\OneDrive\Documents\2017\Projects\3825B\3825B\_GEO\RDWY\modif\ter\CA00D\_GEO\TECH\sc\3825B\_Geo\_xsi.1.166+50-257+70.dgn

6/23/16

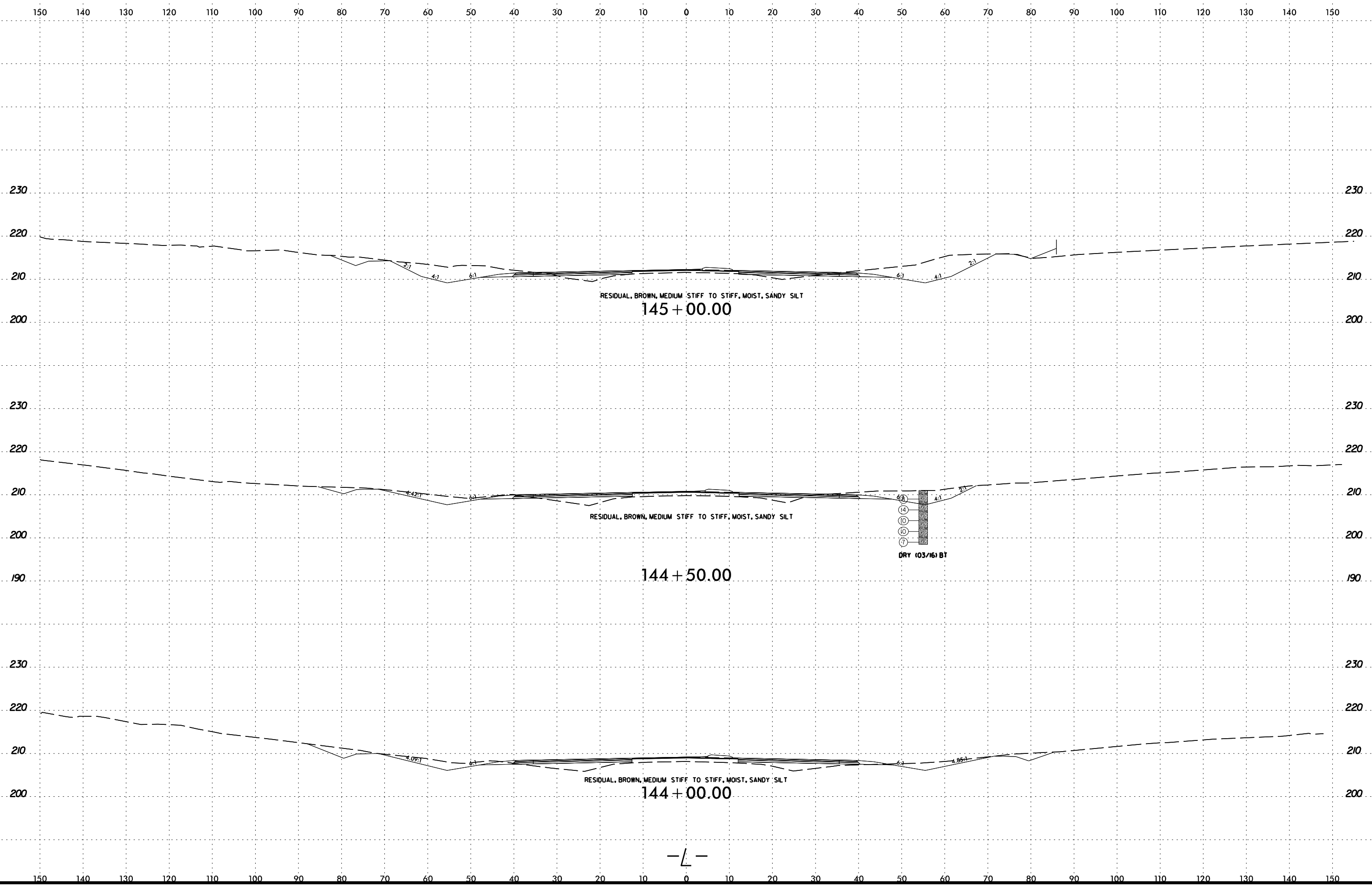

2/23/2017  
 M:\N\NCD01\R-3825B\R-3825B.GEO\_RDWY.mxd  
 C:\Users\lmgton





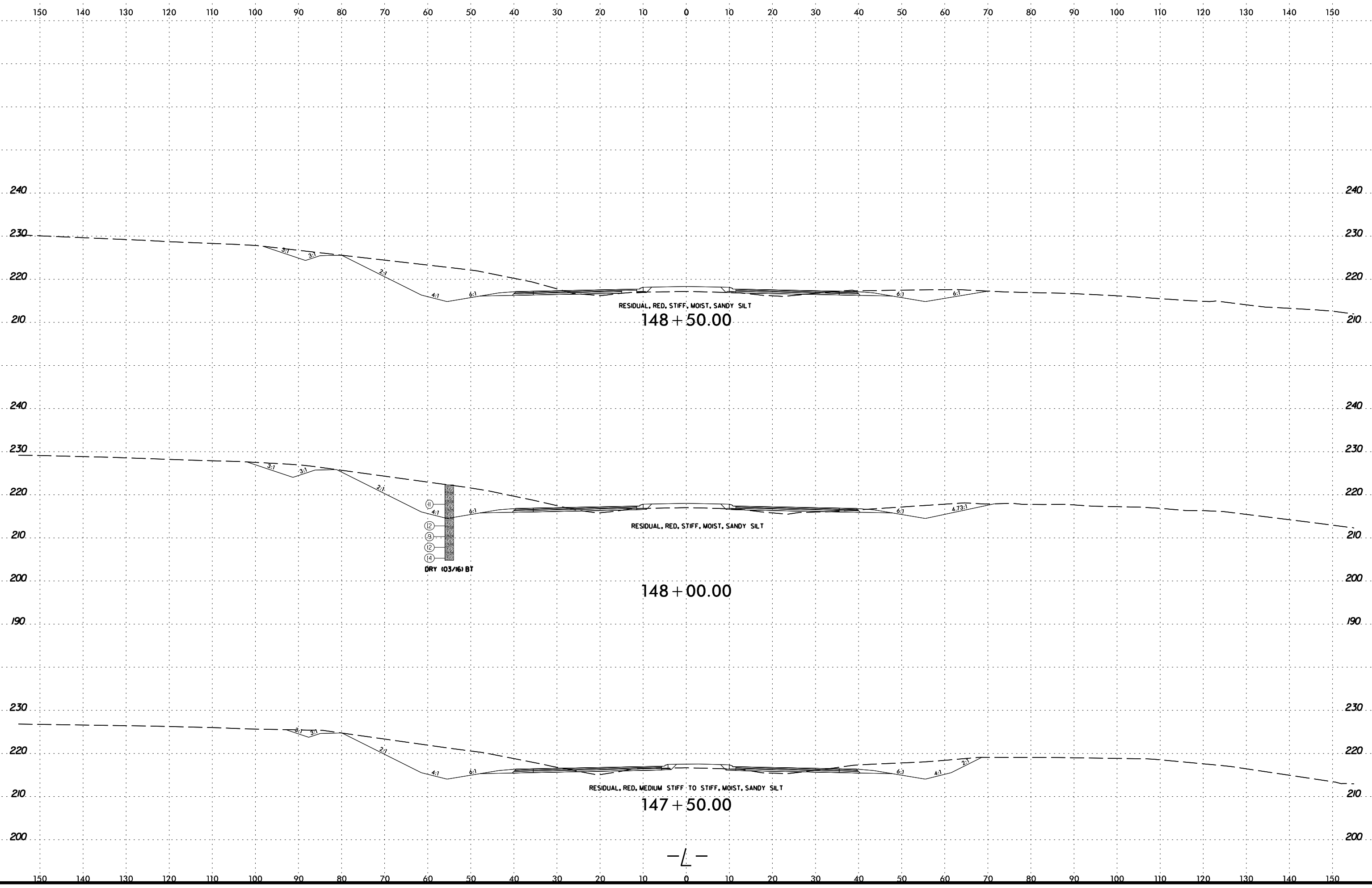

6/23/16

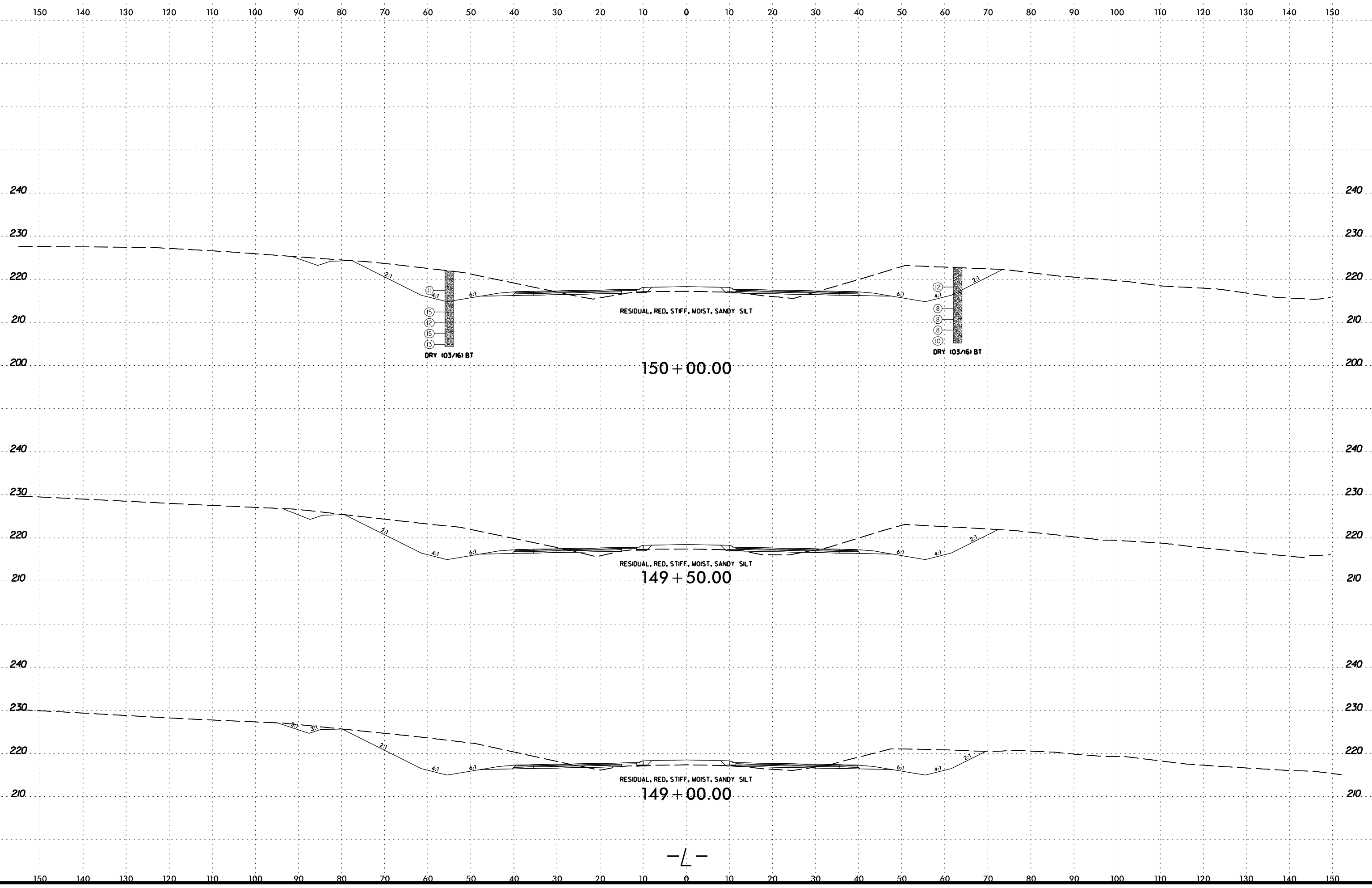

2/23/2017  
M:\N\NCD01\R-3825B\GEO.\RDWY.mxd  
C:\Users\limgton



6/23/16

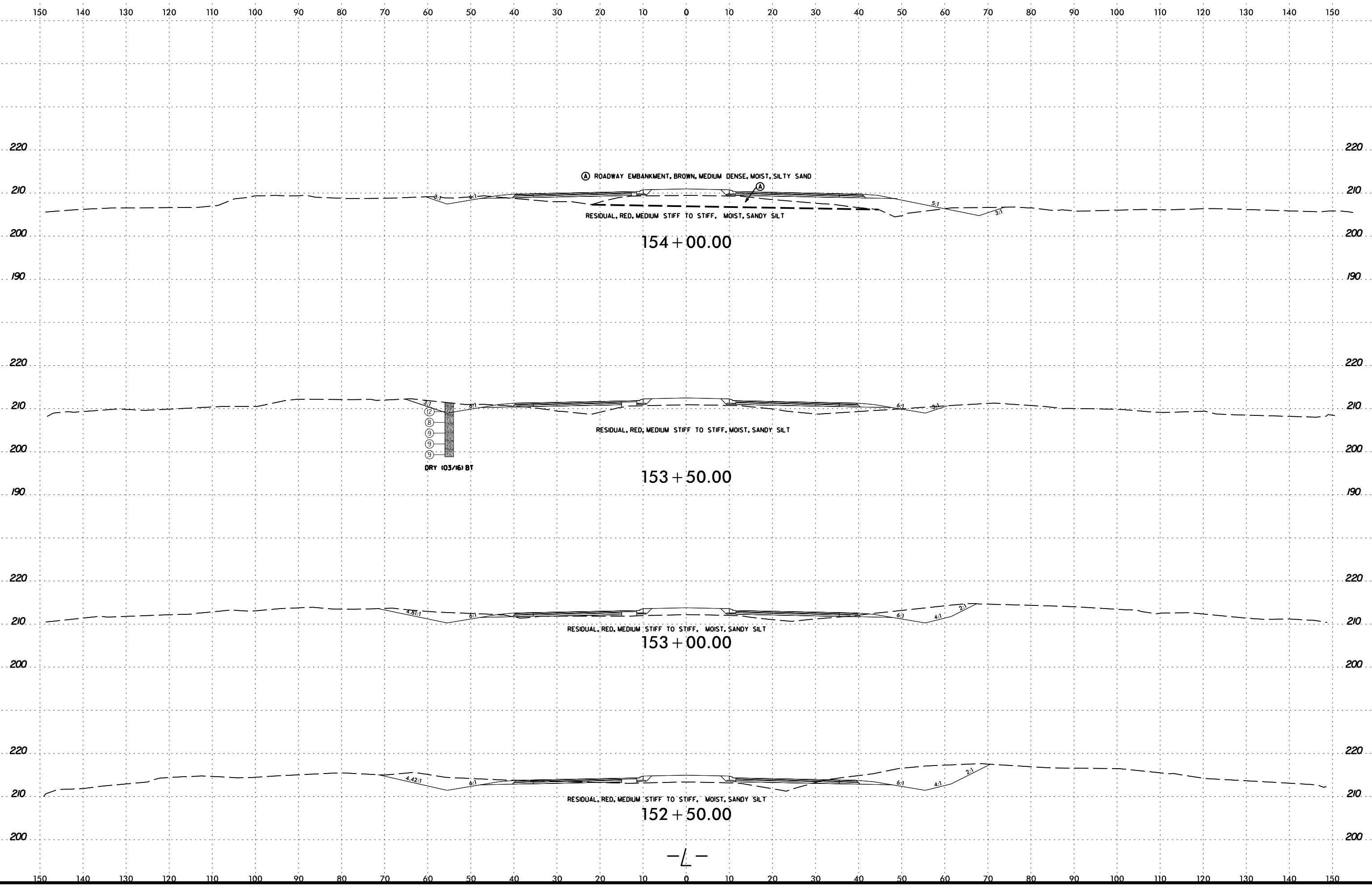

2/23/2017  
M:\N\NCD01\R-3825B\R-3825B.GEO\_RDWY.mxd  
C:\ur\lmgton

6/23/16

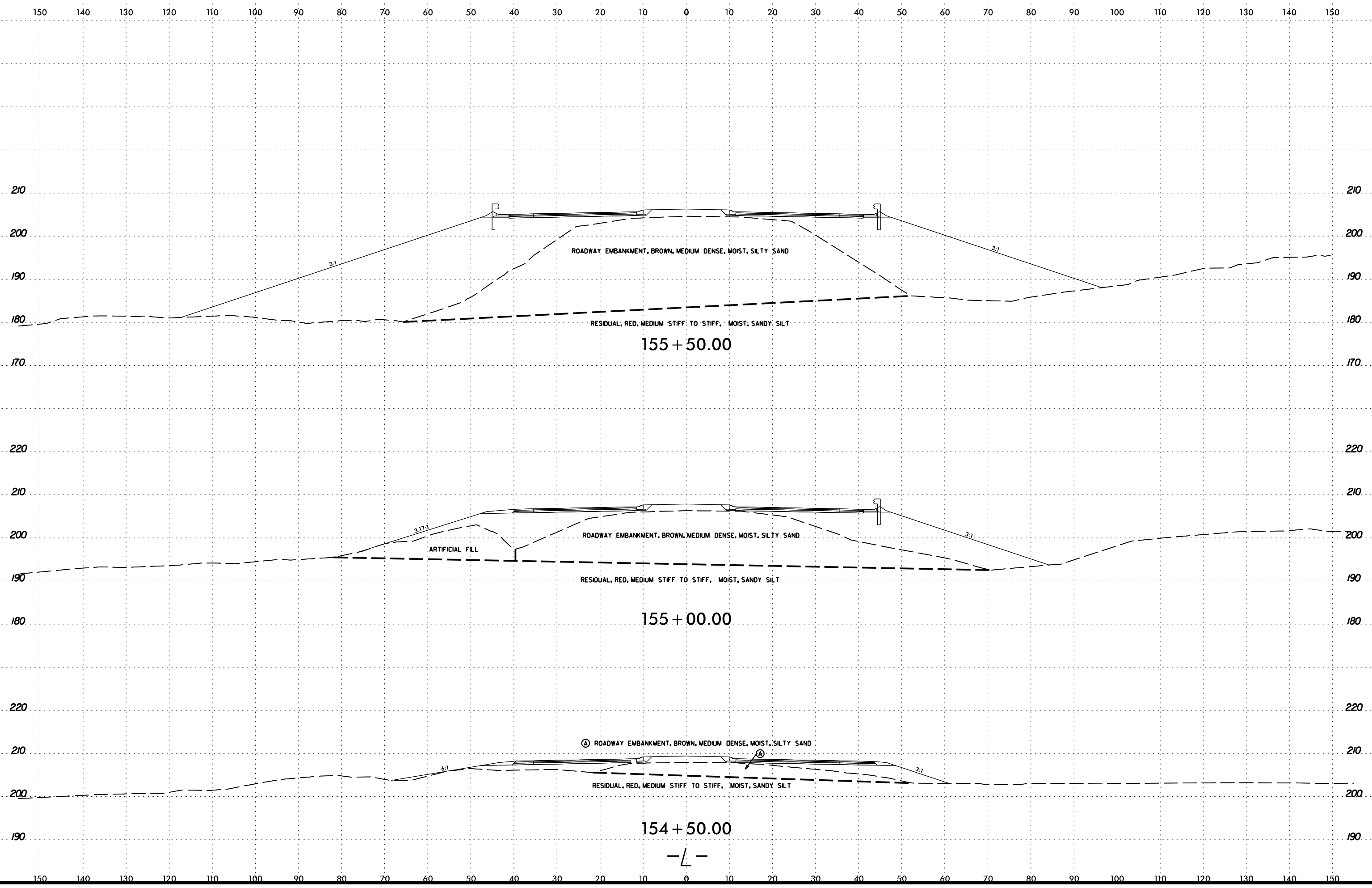

2/23/2017  
C:\Users\mcc01\OneDrive\Documents\R-3825B\GEO.\RDWY.mxd\ref\CA00.GEOTECH\sc\R3825B\_Geo\_xsl.1.166+50-257+70.dgn

6/23/16

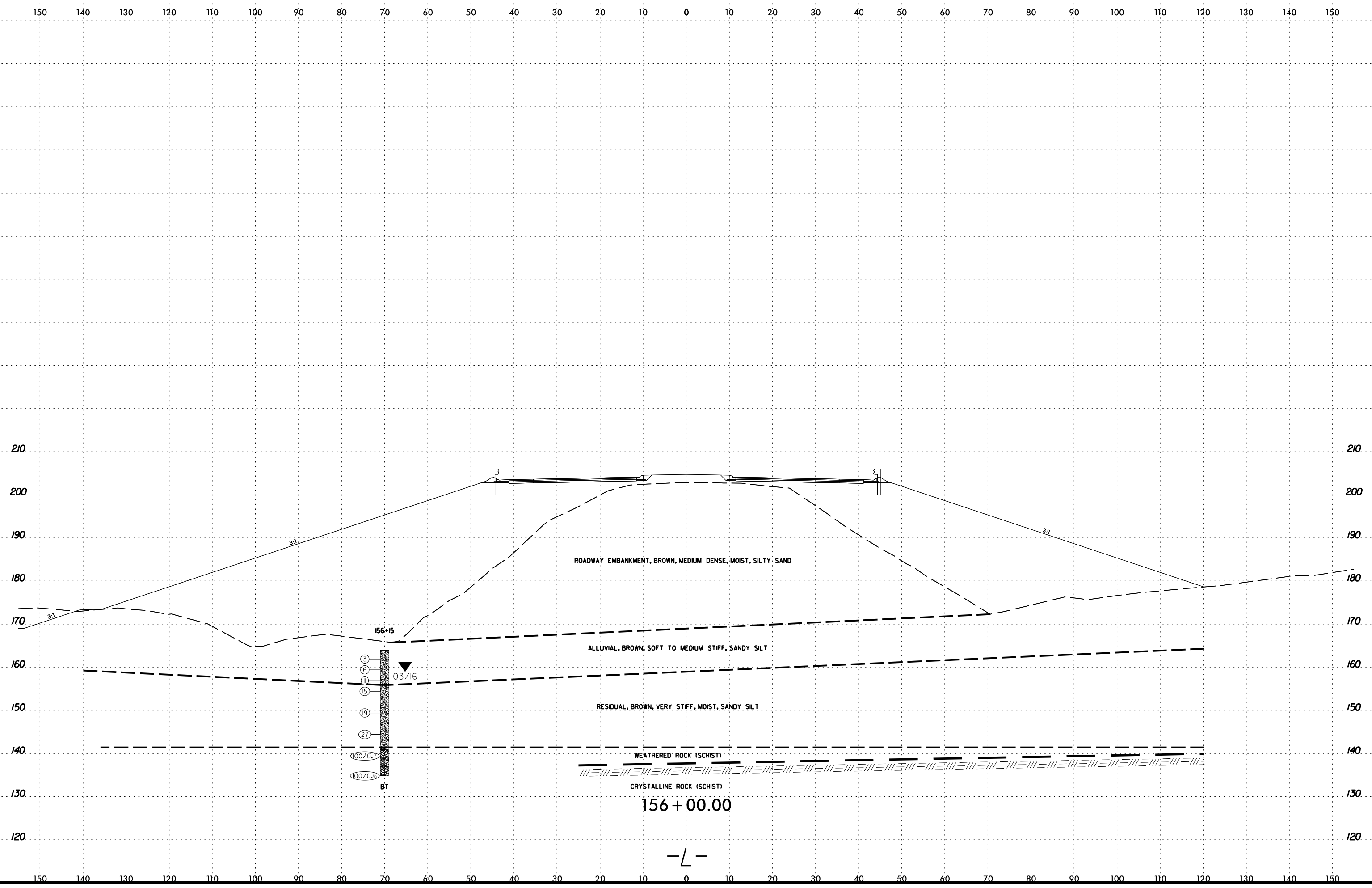

2/23/2017  
 M:\N\NCD01\R-3825B\R-3825B.GEO...RDWY...modif...er\CA0D...GEO\TECH\sc\R3825B\_Geo\_xsl.1.166+50-257+70.dgn  
 C:\ur\imgton









6/23/16

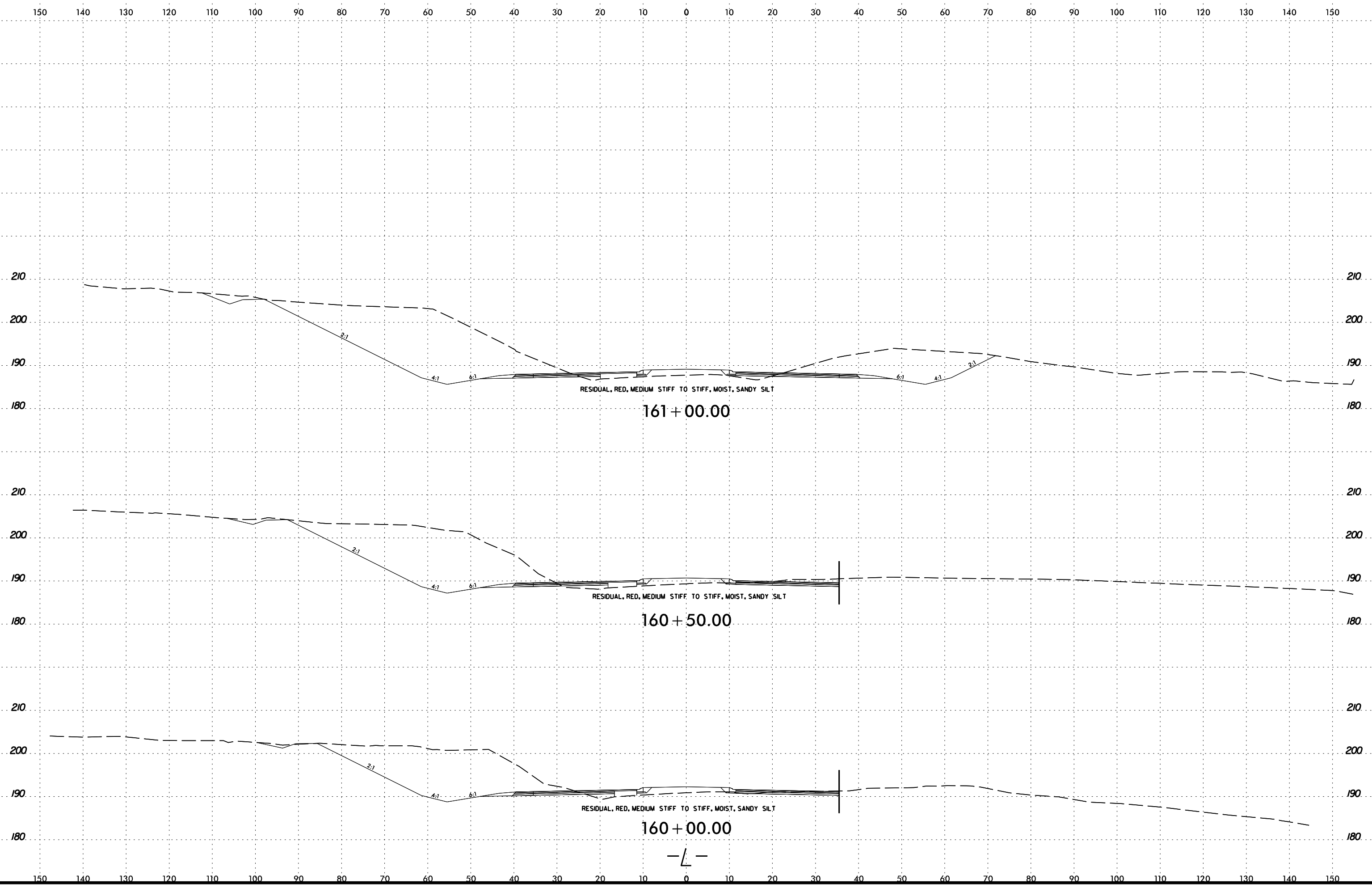

2/23/2017  
C:\Users\mcc01\OneDrive\Documents\Projects\3825B\Geo\RDWY.mxd\166+50-257+70.dgn

6/23/16

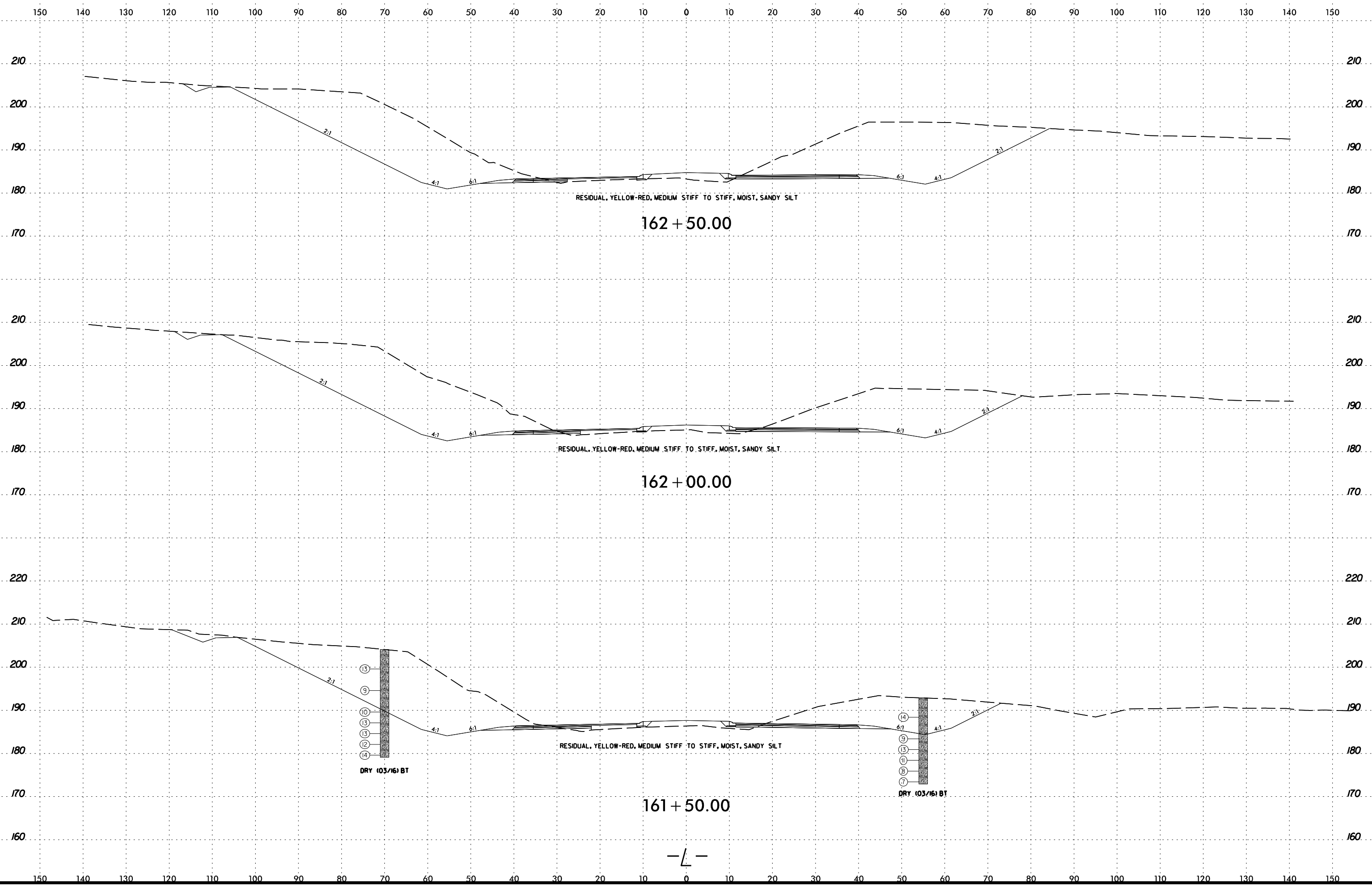

2/23/2017  
 M:\N\CD01\R-3825B\R-3825B.GEO\_RDWY.mxd  
 C:\Users\lmgton

6/23/16

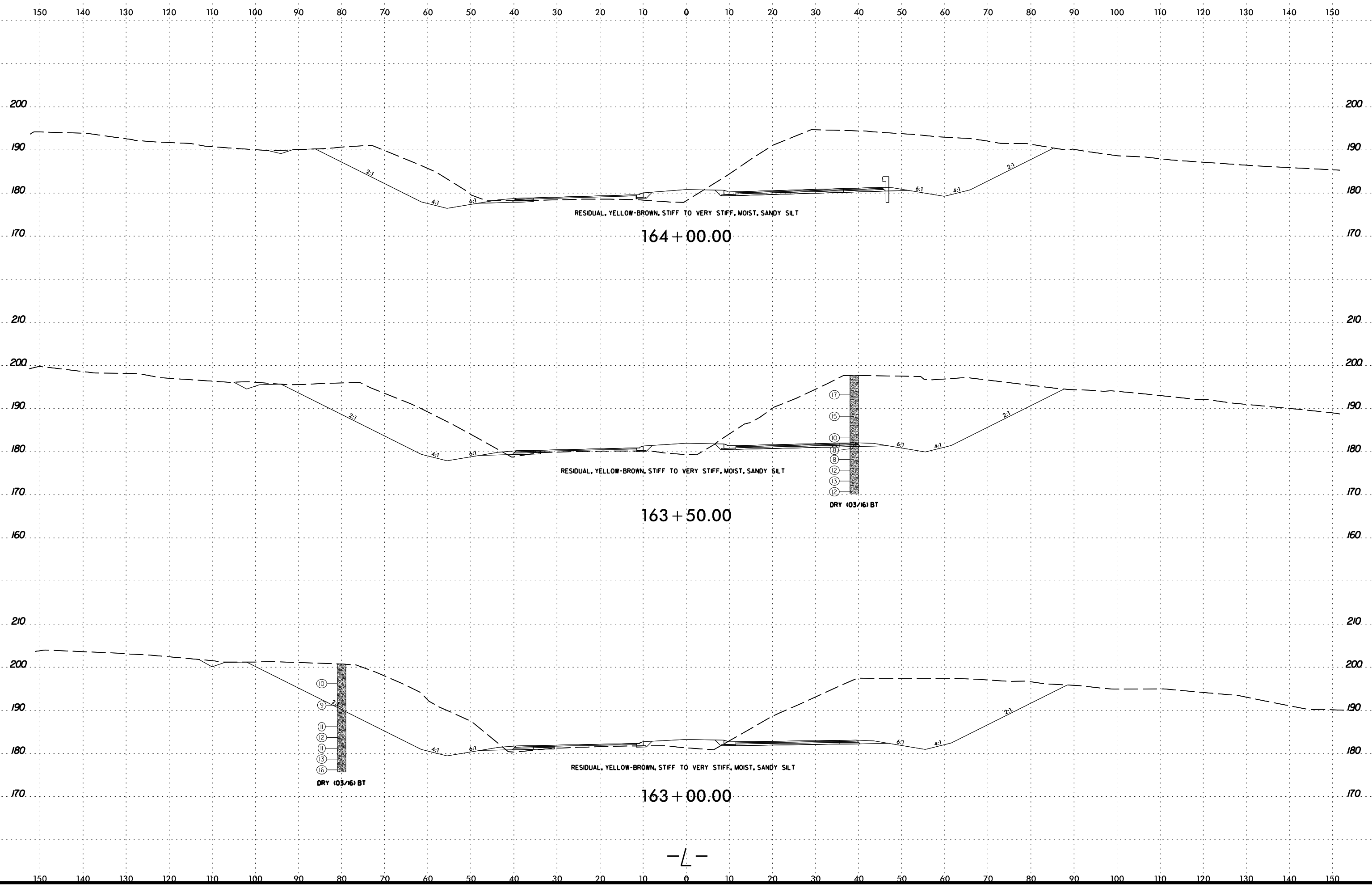

2/23/2017  
 M:\N\NCD01\R-3825B\R-3825B.GEO.RDWY.mxd  
 C:\Users\lmgton

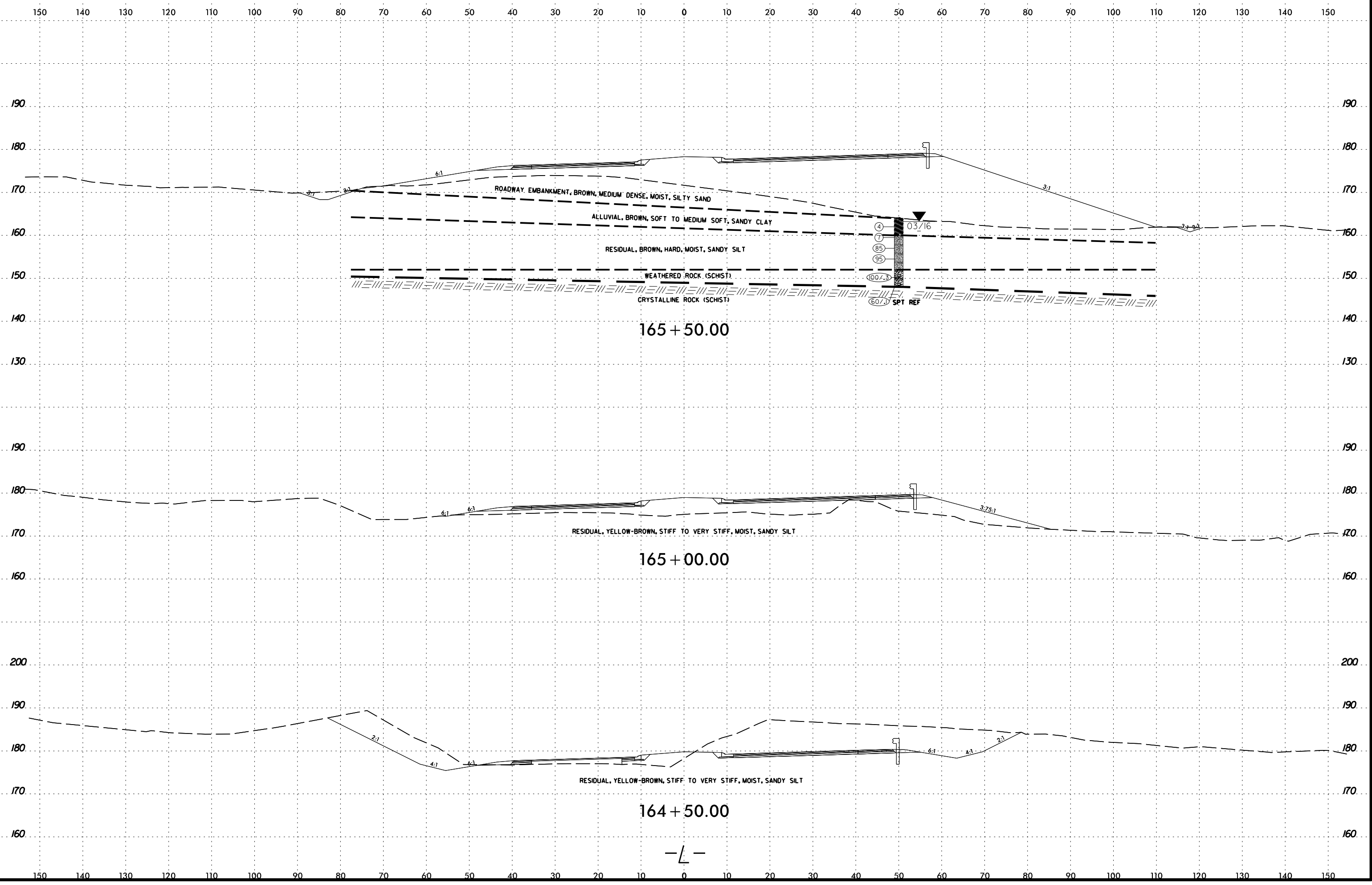

6/23/16

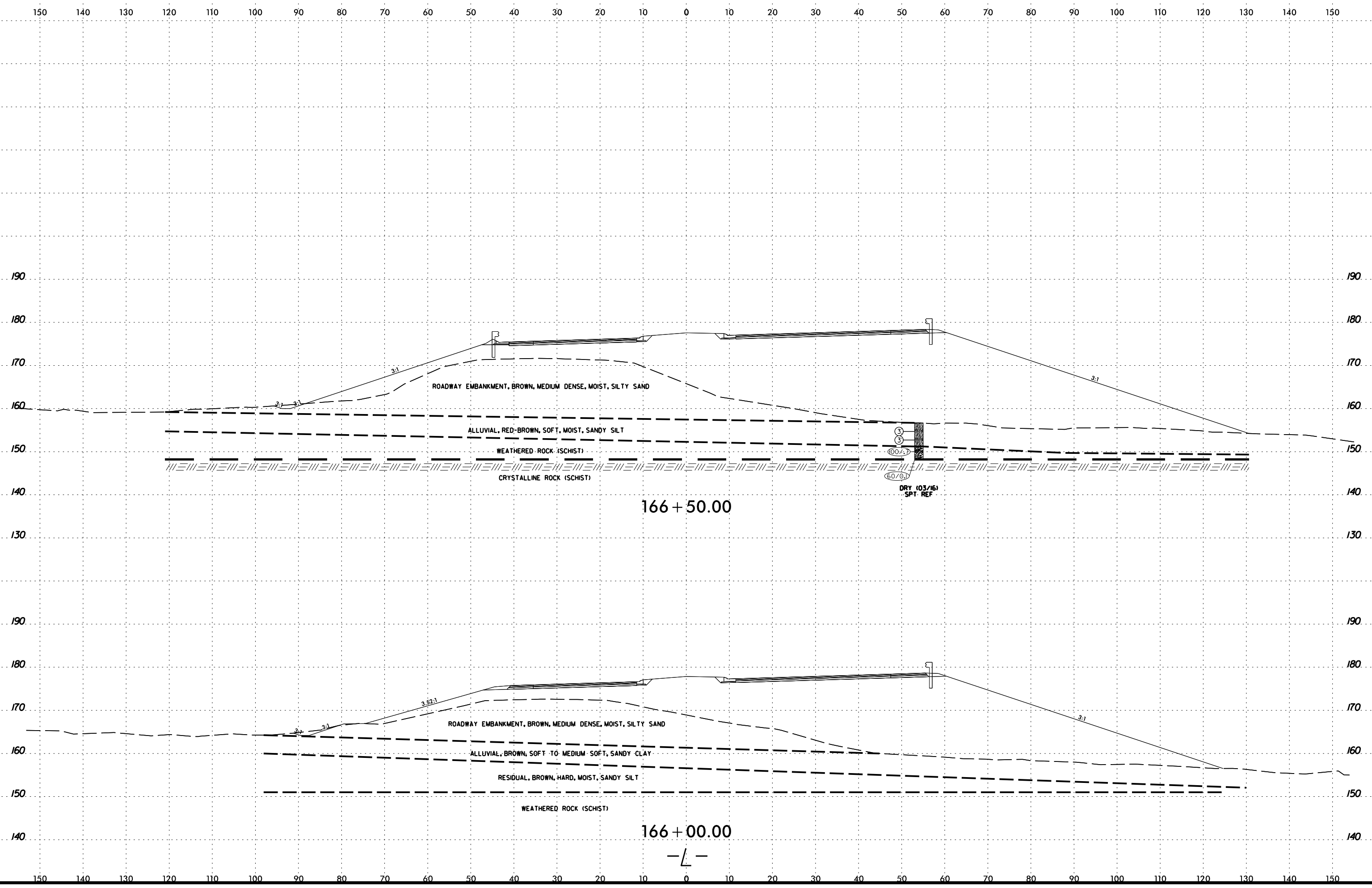

2/23/2017  
M:\N\CD01\R-3825B\GEO.\RDWY.mxd  
C:\Program Files\Autodesk\AutoCAD 2010\AutoCAD.exe

6/23/16

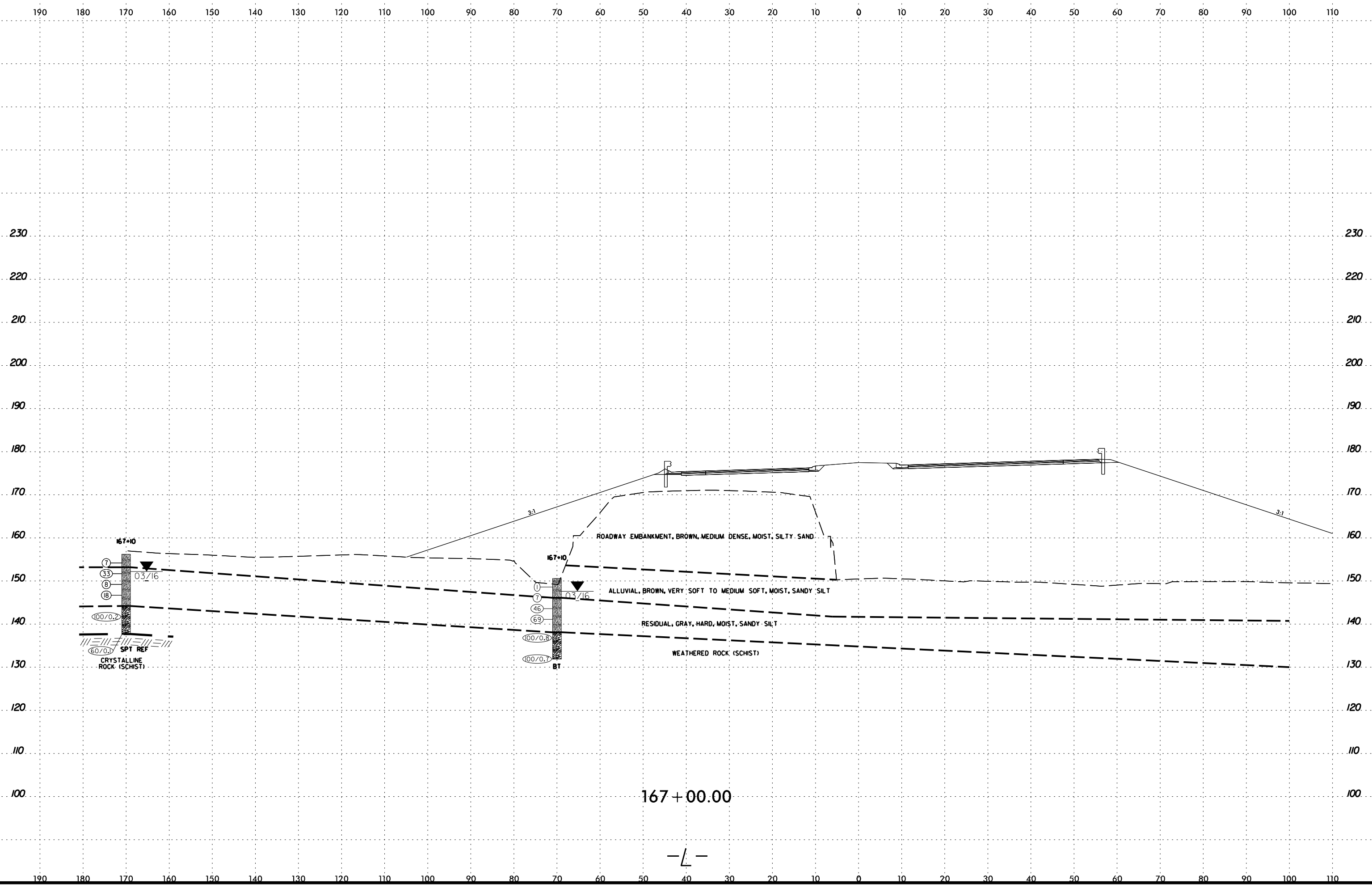

2/23/2017  
 M:\N\NCD01\R-3825B\R-3825B.GEO\_RDWY.mxd  
 C:\Program Files\Autodesk\AutoCAD 2010\AutoCAD.exe

6/23/16

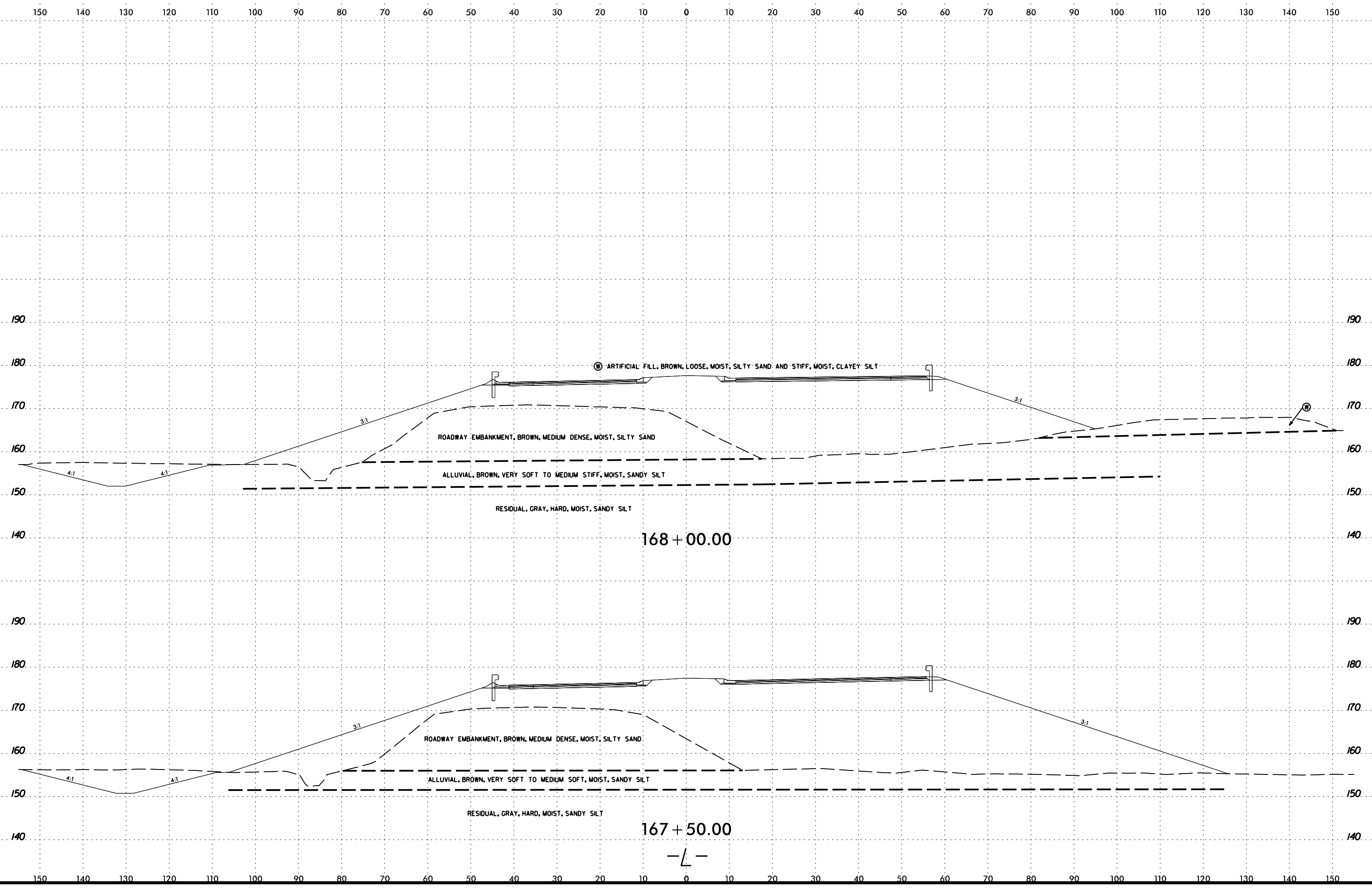

2/23/2017  
 M:\N\CD01\R-3825B-R-3825B-GEO\_RDWY\_modif\er\CA00\_GEO\TECH\sc\R3825B\_Geo\_xsl.1.166+50-257+70.dgn  
 C:\ur\ington





6/23/16

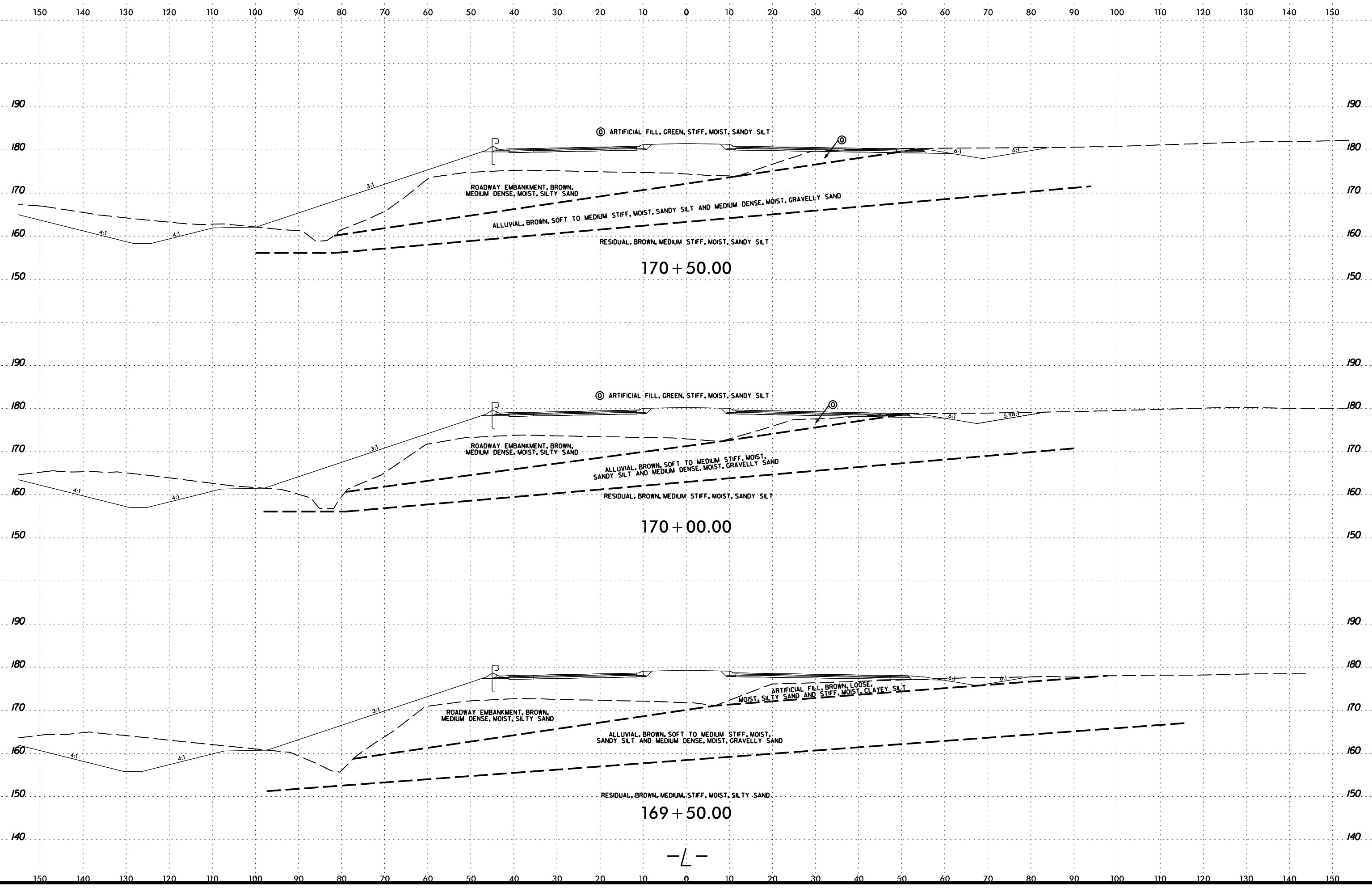

2/23/2017 11:58:00 AM C:\Users\mcc01\OneDrive\Documents\Projects\3825B\Geo\RDWY.mxd\ref\CA00.GEOTECH\3825B\_Geo\_xsi.1\66+50-257+70.dgn

6/23/16

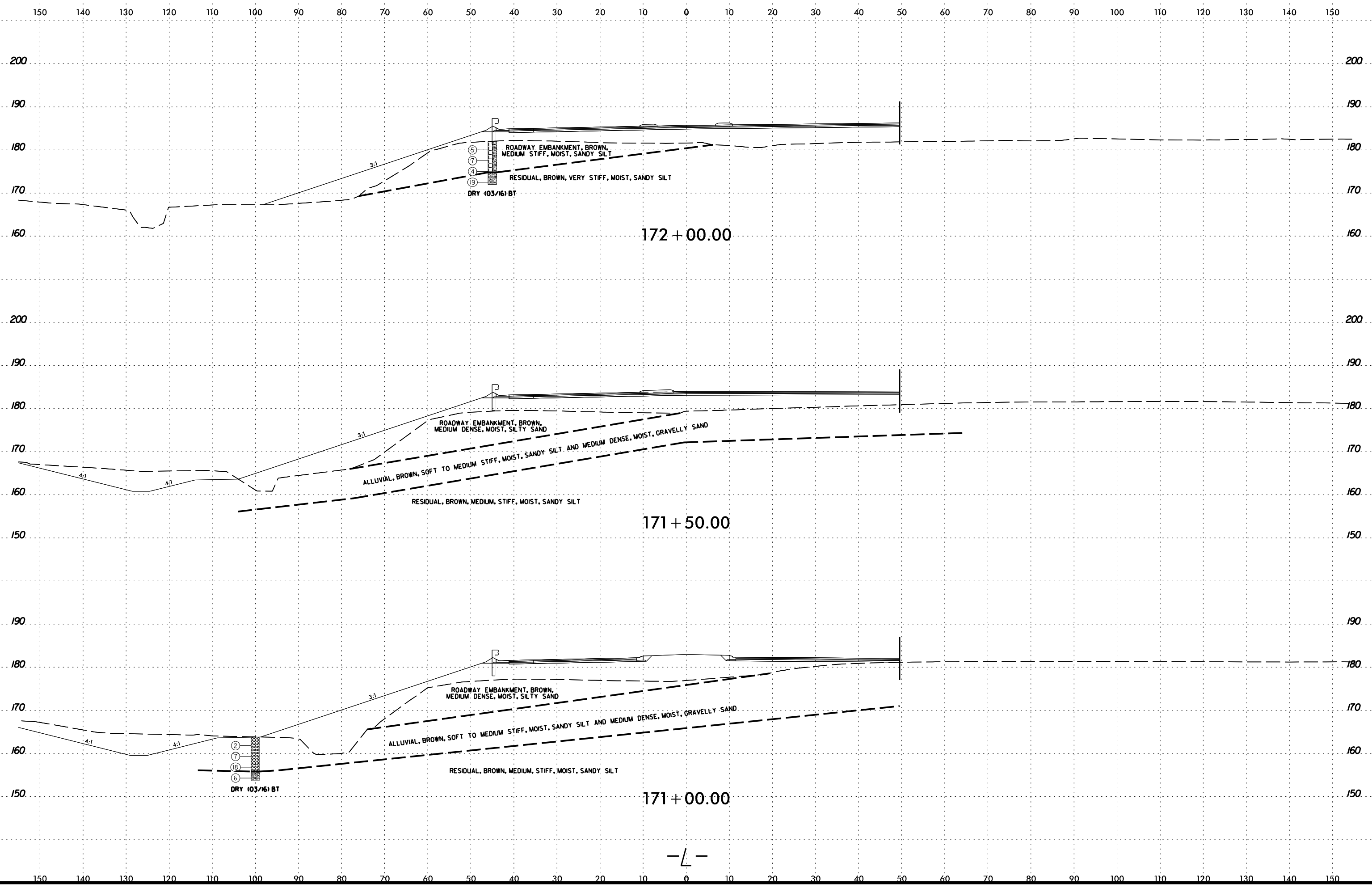

2/23/2017  
 M:\N\CD01\R-3825B\R-3825B.GEO\_RDWY.mxd  
 C:\Program Files\Autodesk\AutoCAD 2010\AutoCAD.exe

6/23/16

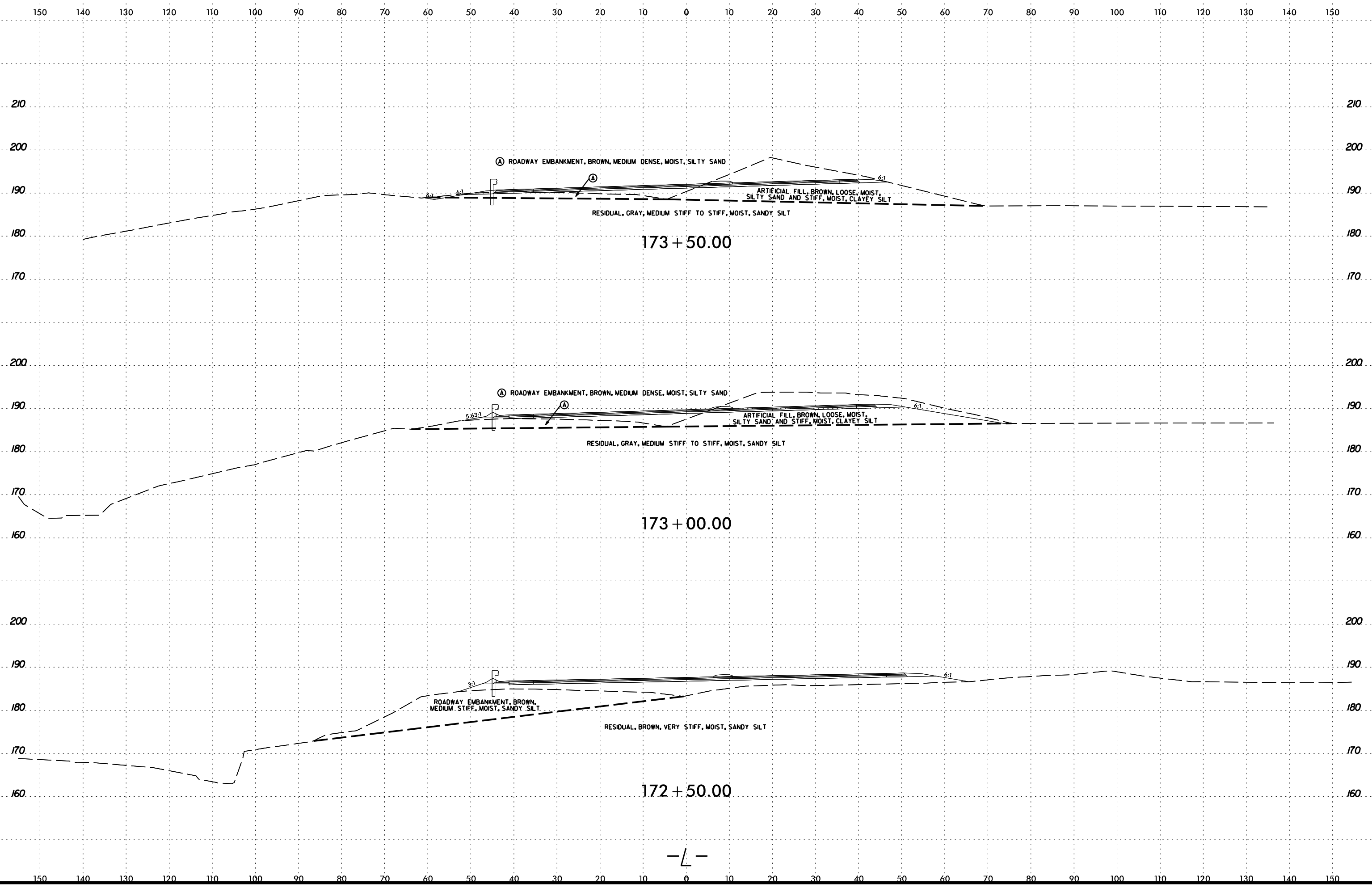

2/23/2017  
 M:\N\2017\17-R-3825B-R-3825B-GEO\_RDWY.mxd\ref\CA00D\_GEO1TECH\sc\R3825B\_Geo\_xsi.1.166+50-257+70.dgn  
 C:\Users\imington

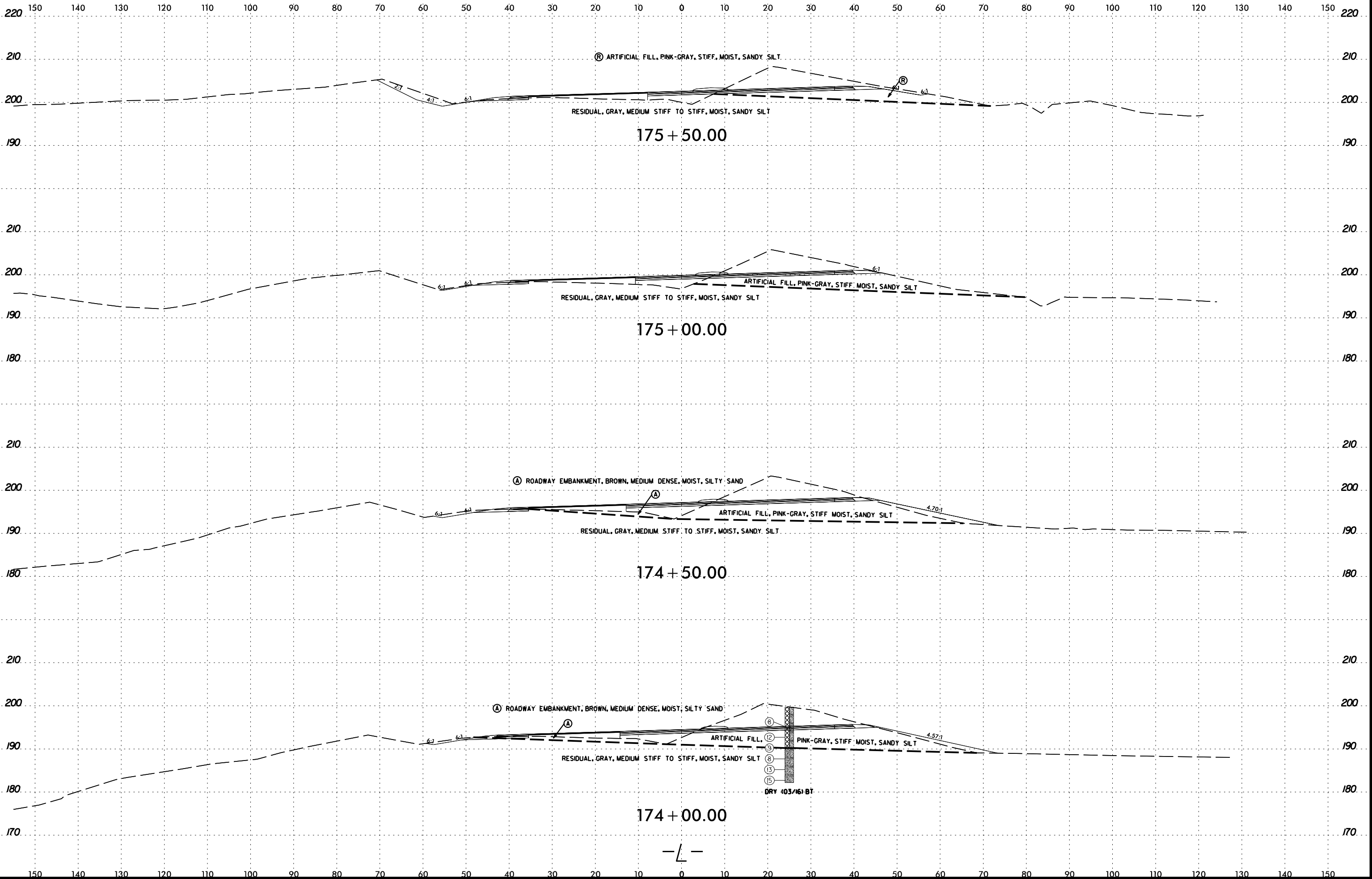

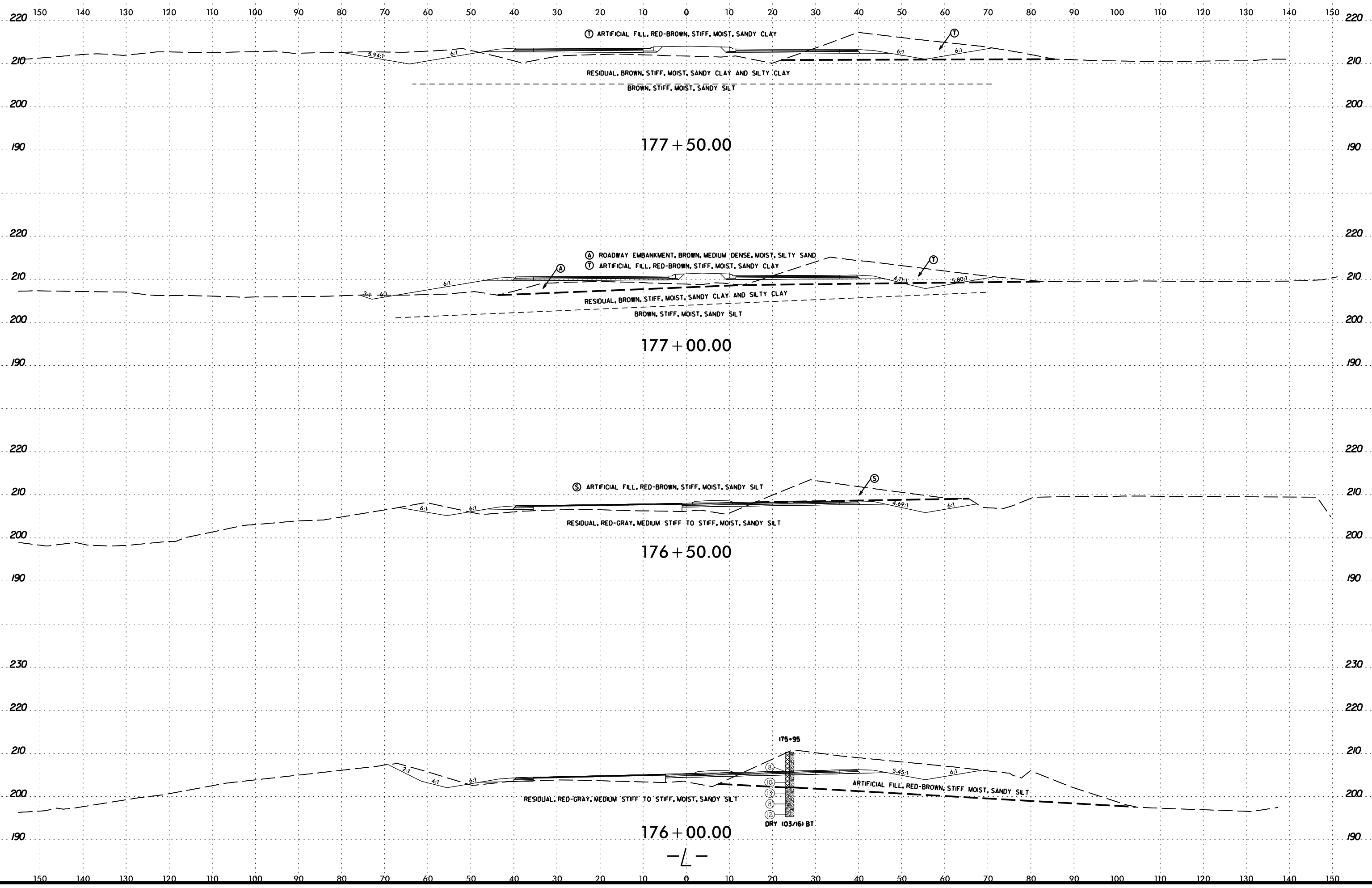

6/23/16

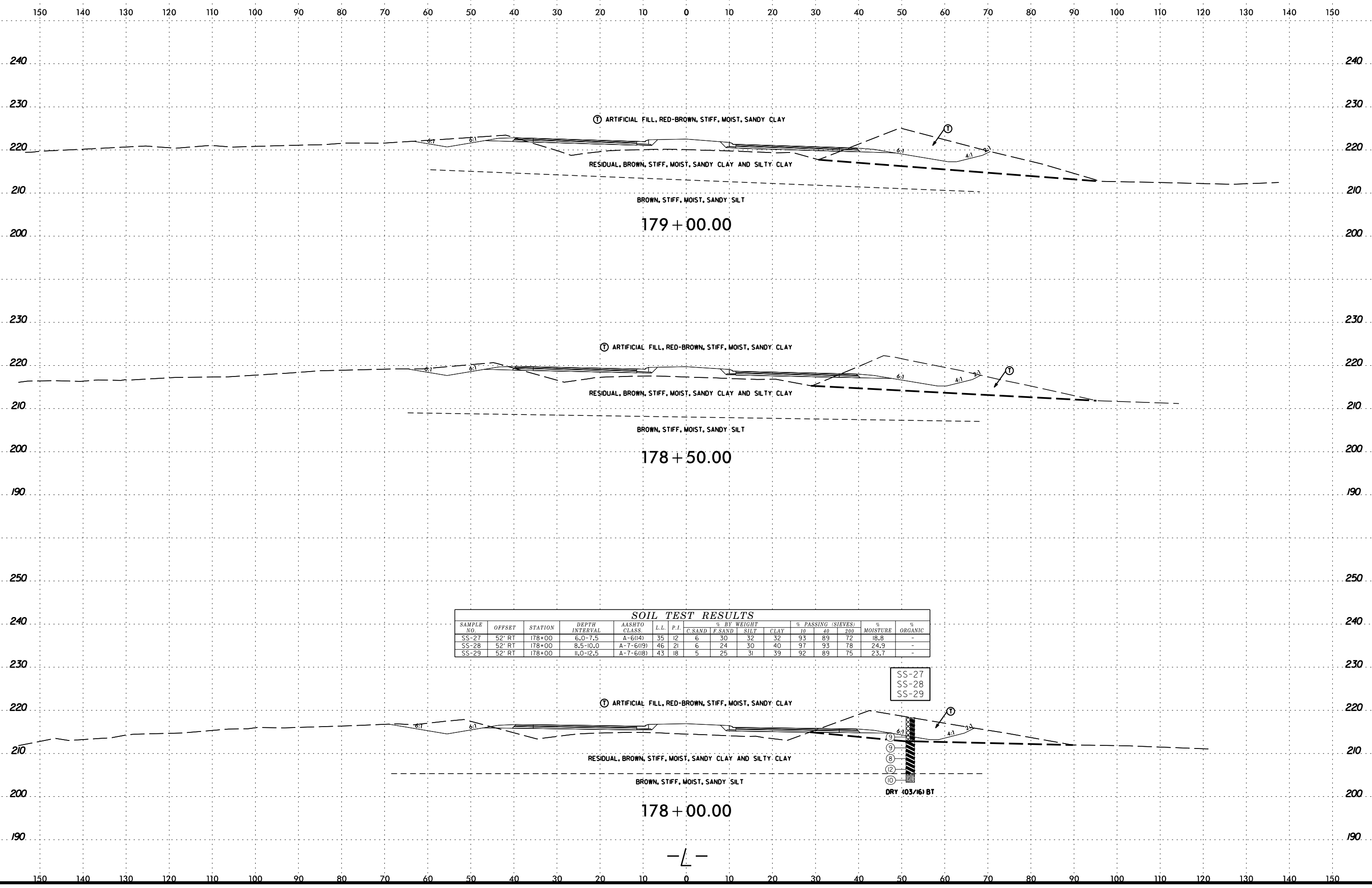

SOIL TEST RESULTS															
SAMPLE NO.	OFFSET	STATION	DEPTH INTERVAL	AASHTO CLASS.	L.L.	P.I.	% BY WEIGHT				% PASSING (SIEVES)			% MOISTURE	% ORGANIC
							C. SAND	F. SAND	SILT	CLAY	10	40	200		
SS-27	52' RT	178+00	6.0-7.5	A-6(14)	35	12	6	30	32	32	93	89	72	18.8	-
SS-28	52' RT	178+00	8.5-10.0	A-7-6(19)	46	21	6	24	30	40	97	93	78	24.9	-
SS-29	52' RT	178+00	11.0-12.5	A-7-6(18)	43	18	5	25	31	39	92	89	75	23.7	-

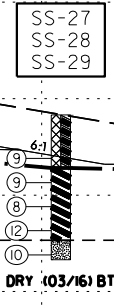

2/23/2017 11:58:00 AM C:\Users\mcc01\OneDrive\Documents\R-3825B\GEO\RDWY\modif\er\CA00\_GEO1TECH\ssc\R3825B\_Geo\_xsi.1.166+50+257+70.dgn





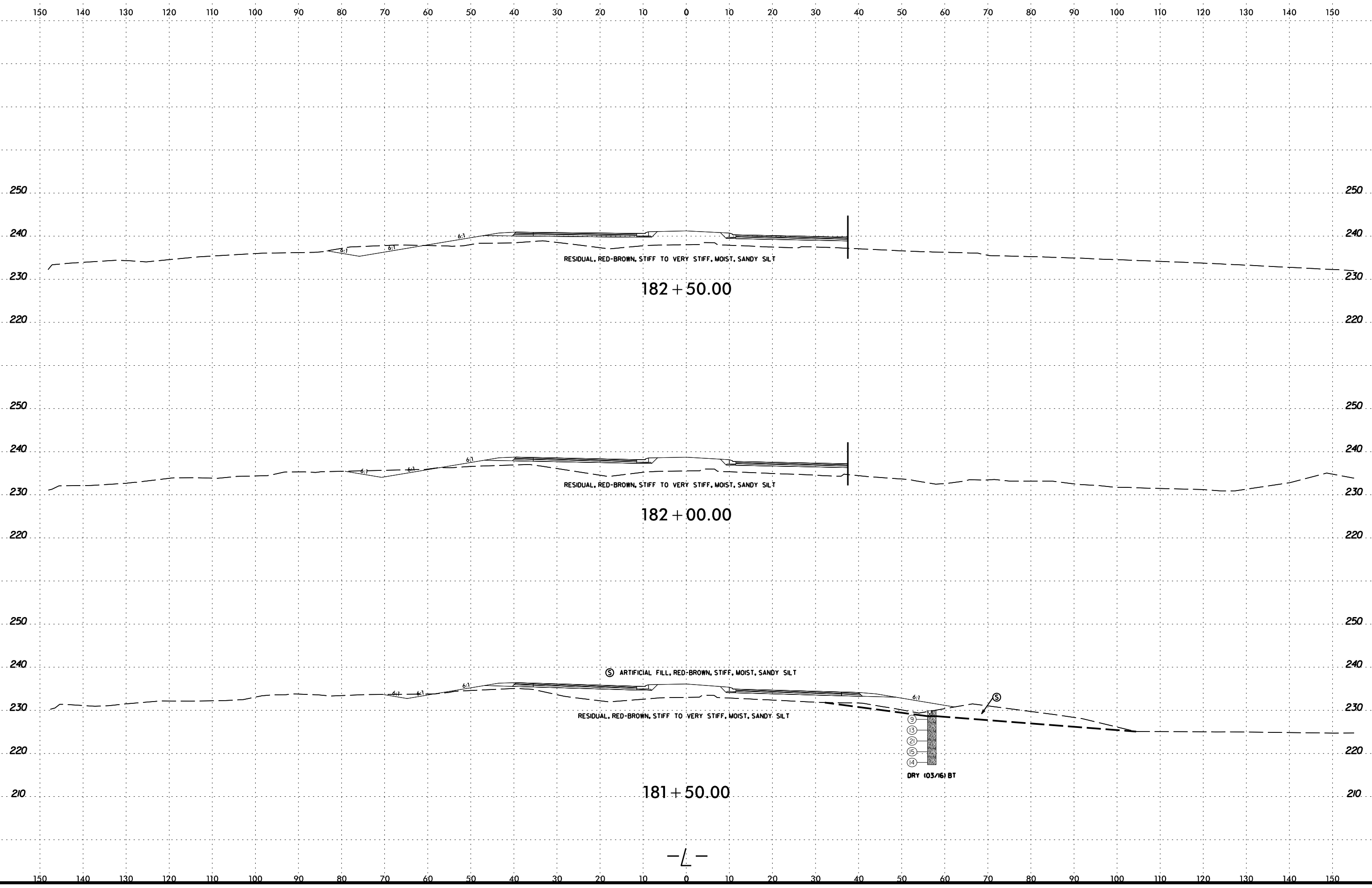

2/23/2017  
 M:\N\NCD01\R-3825B\R-3825B.GEO.RDWY...modif\er\CA00D.GEOTECH\sc\R3825B.Geo.xst.1.166+50-257+70.dgn  
 C:\ur\ington

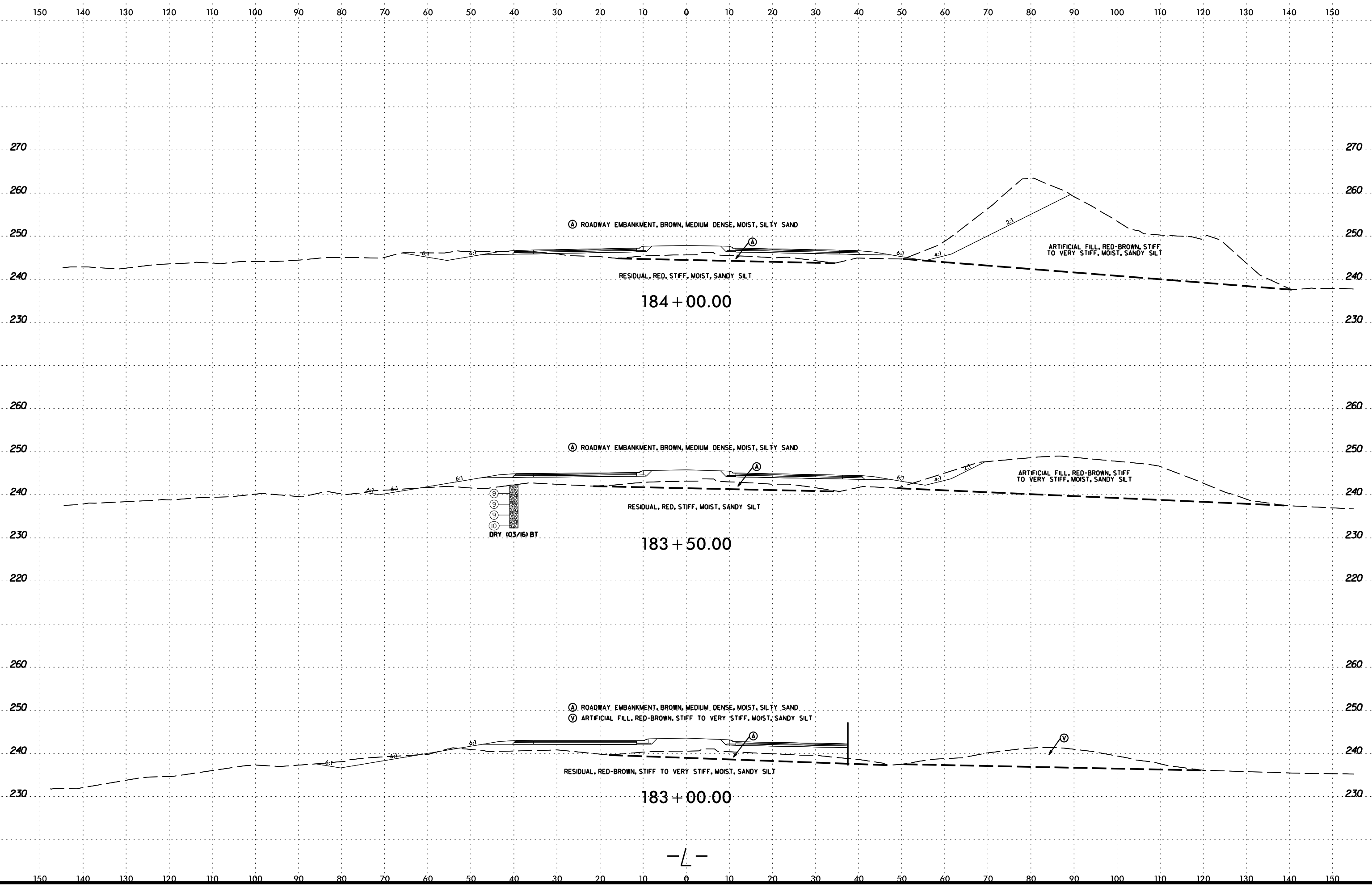

2/23/2017  
 M:\N\CD01\R-3825B\GEO.RDWY.mxd  
 C:\Users\imington



6/23/16

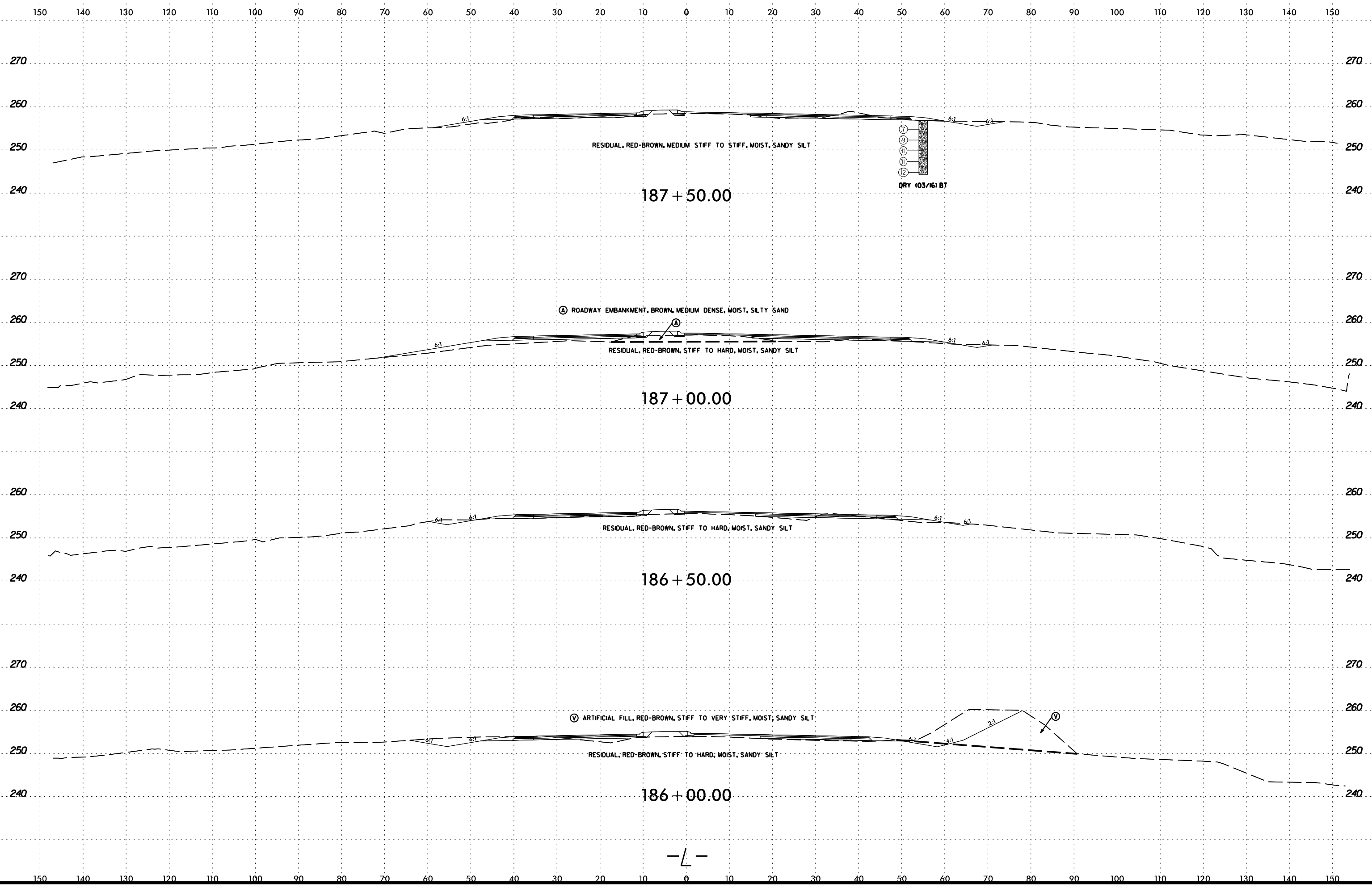

2/23/2017  
M:\N\NCD01\R-3825B\R-3825B.GEO\_RDWY.mxd  
C:\Users\imington

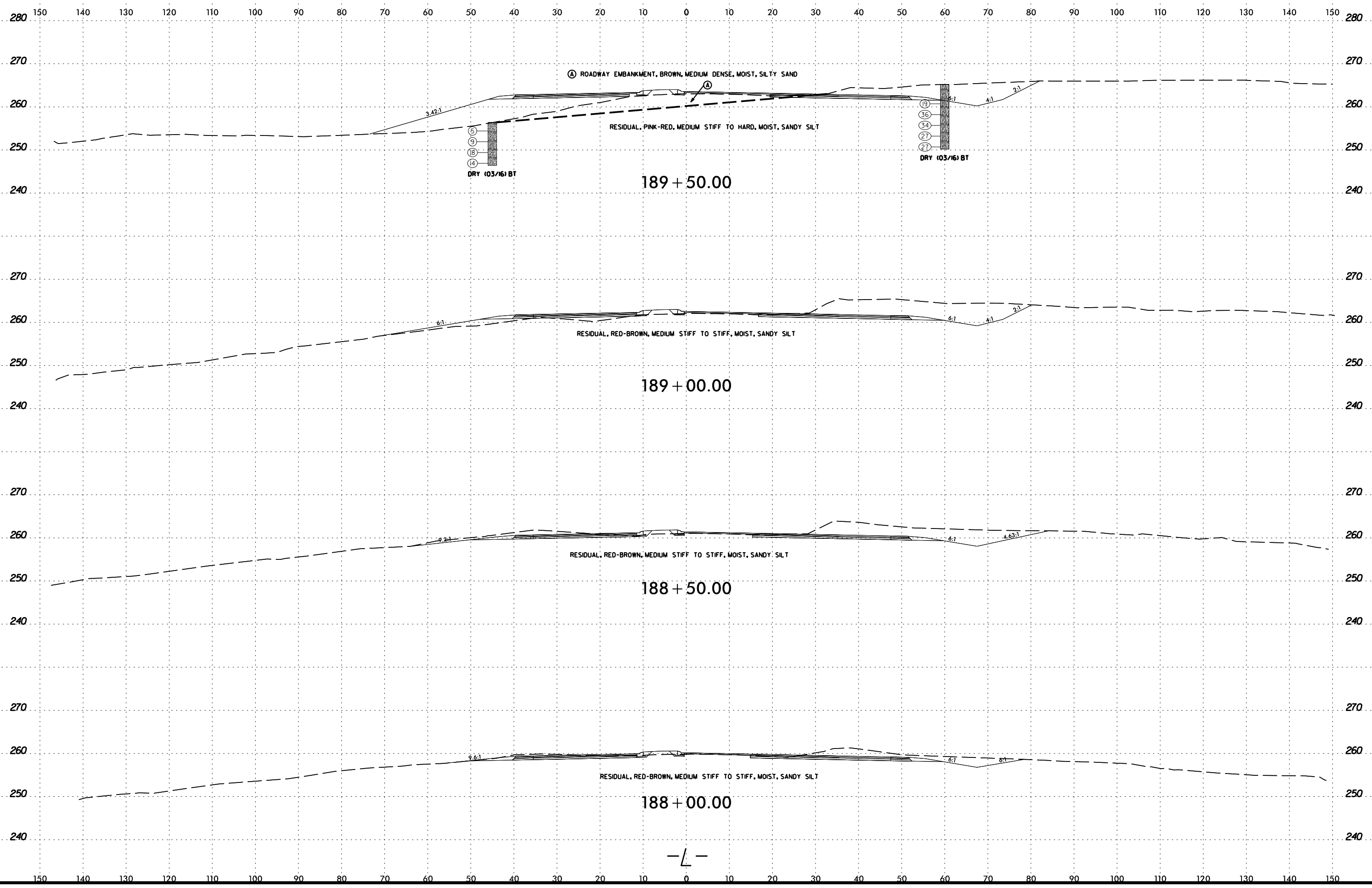

2/23/2017  
 M:\N\CD01\R-3825B\R-3825B.GEO\_RDWY.mxd  
 C:\Users\imington





6/23/16

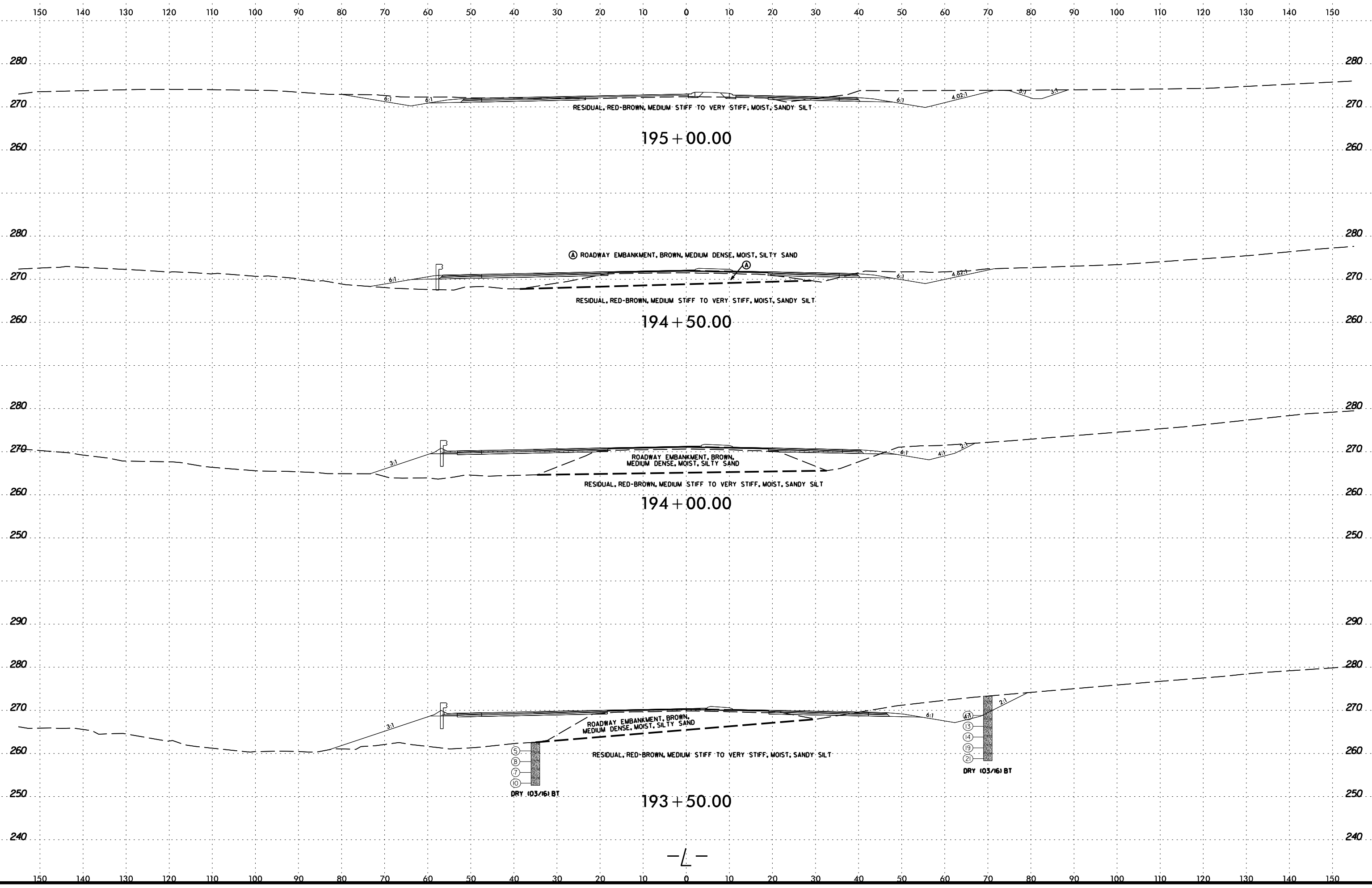

2/23/2017  
M:\N\NCD01\R-3825B\GEO.\RDWY.mxd  
C:\Program Files\Autodesk\AutoCAD 2010\AutoCAD.exe



6/23/16

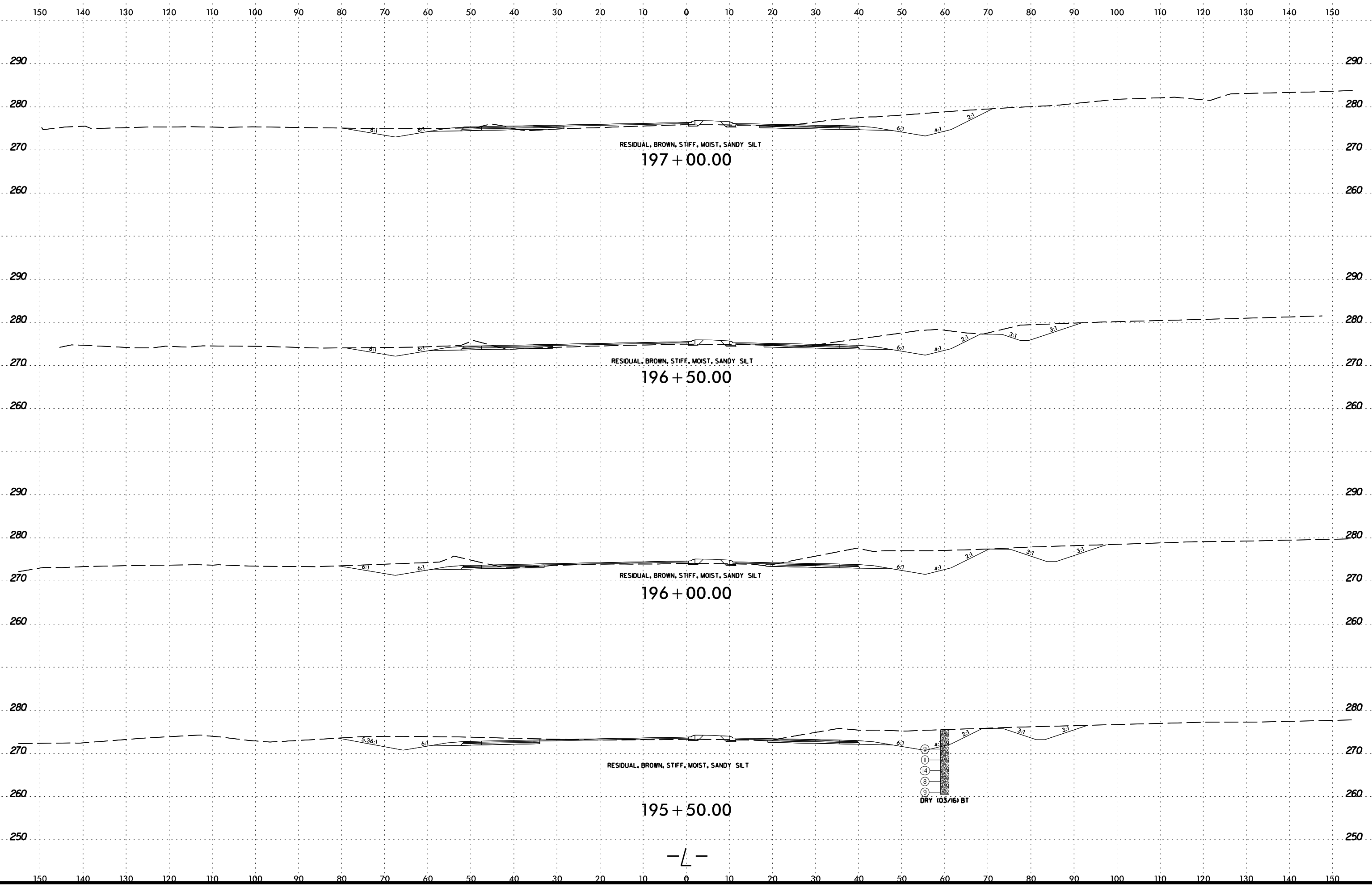

2/23/2017  
C:\Users\mcc01\OneDrive\Documents\2017\Projects\3825B\Geo\RDWY.mxd\166+50-257+70.dgn

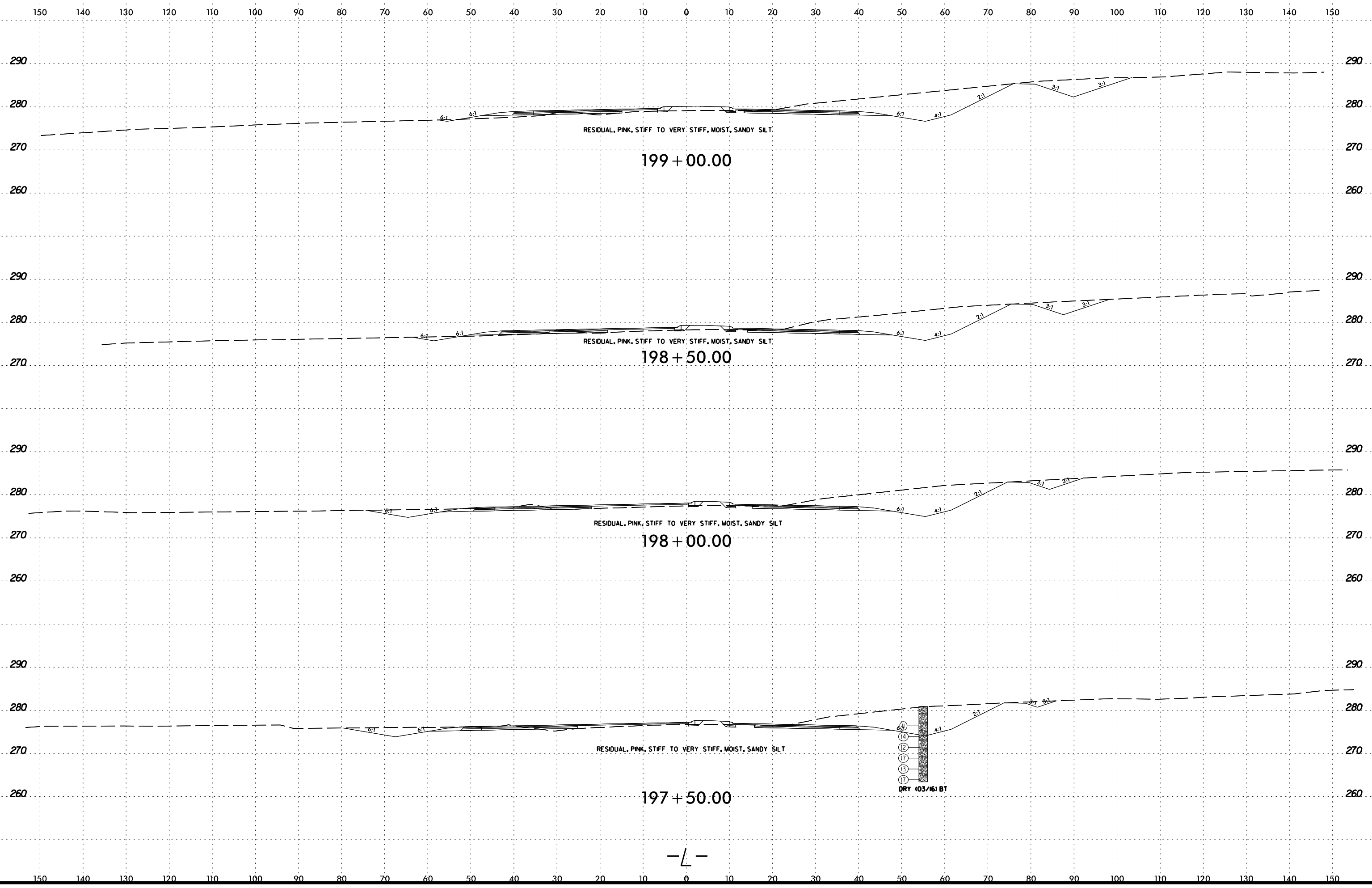

2/23/2017  
 M:\N\CD01\R-3825B\R-3825B.GEO.RDWY.mxd  
 C:\Users\lmgton

6/23/16

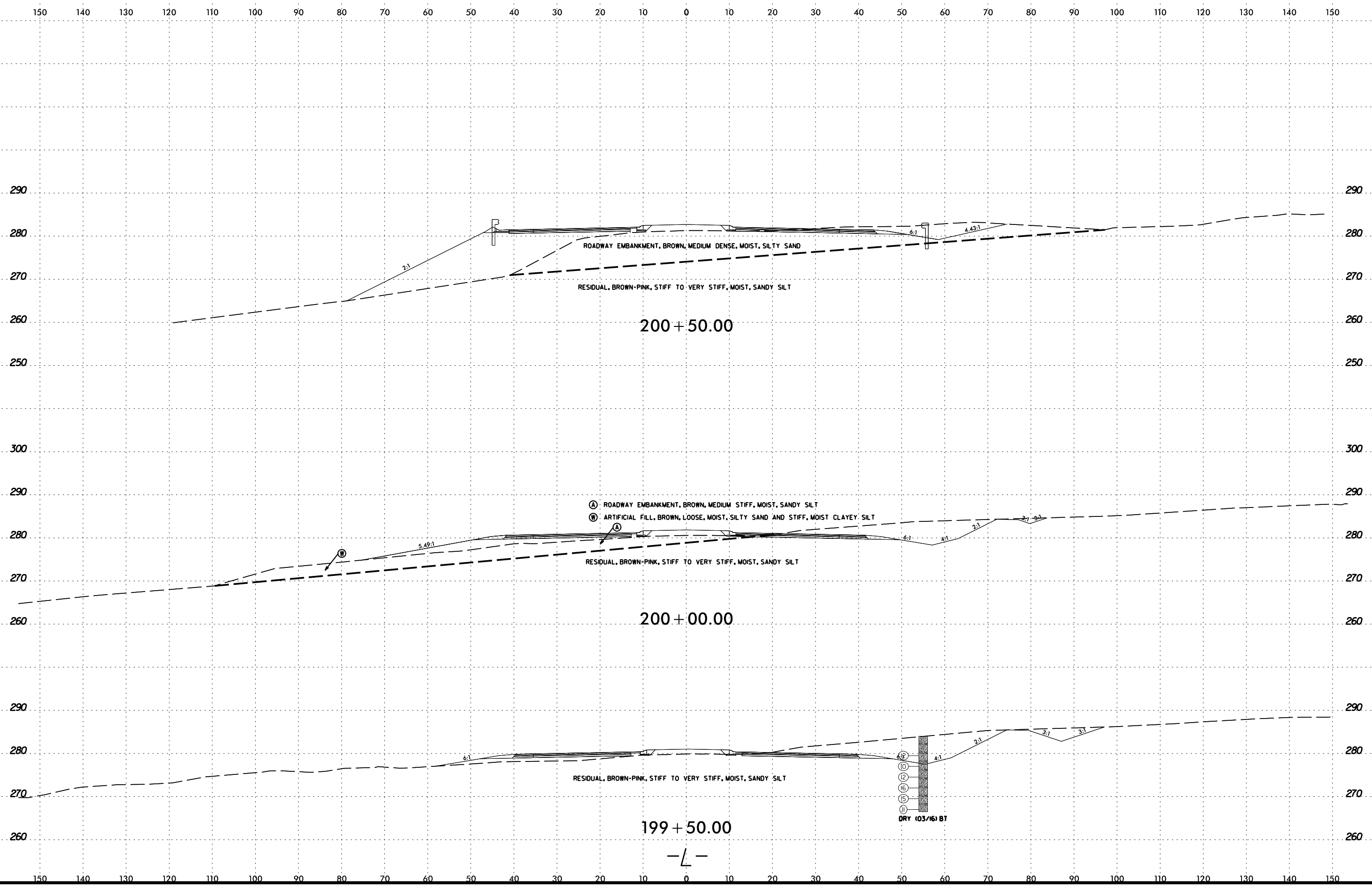

2/23/2017  
C:\Users\mcc01\OneDrive\Documents\R-3825B\GEO\RDWY.mxd\ref\CA00.GEOTECH\sc\R3825B\_Geo\_xsl.1.166+50-257+70.dgn



6/23/16

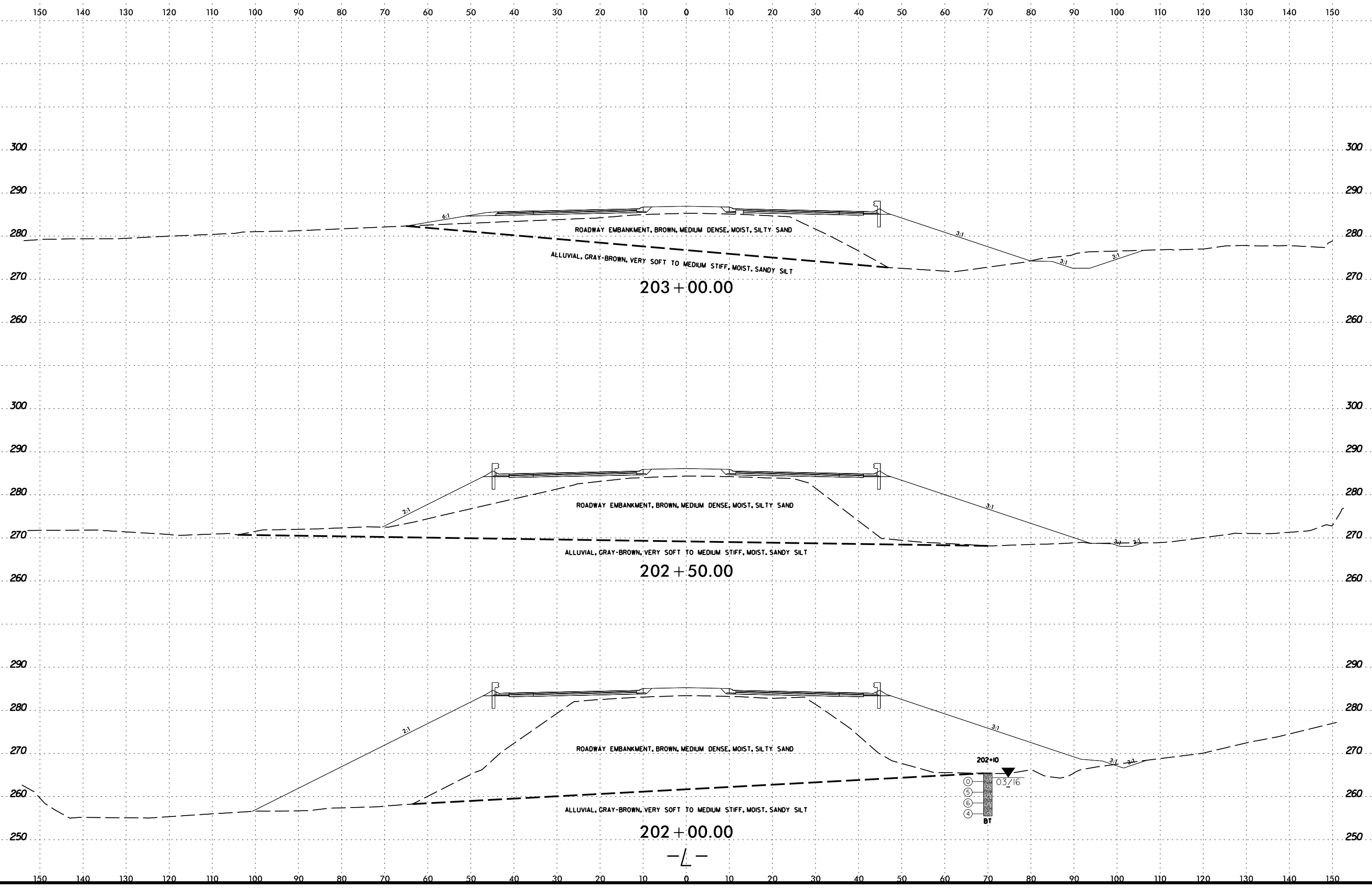

2/23/2017  
C:\Users\mcc01\OneDrive\Documents\R-3825B\GEO\RDWY.mxd\ref\CA00.GEOTECH\sc\R3825B\_Geo\_xsi.1\66+50+257+70.dgn

6/23/16

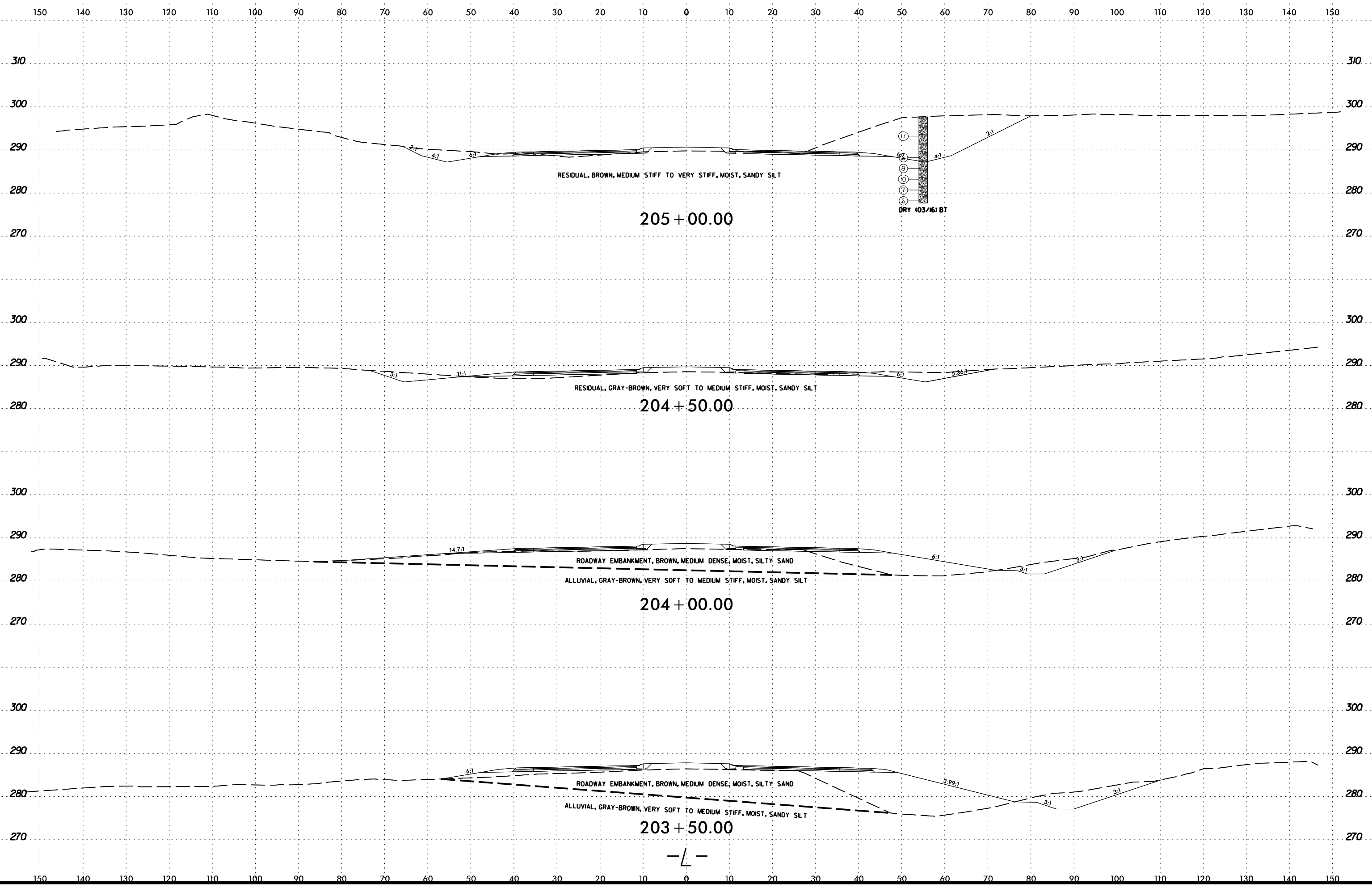

2/23/2017  
M:\N\NCD01\R-3825B\R-3825B.GEO.RDWY.mxd  
C:\ur\imgton







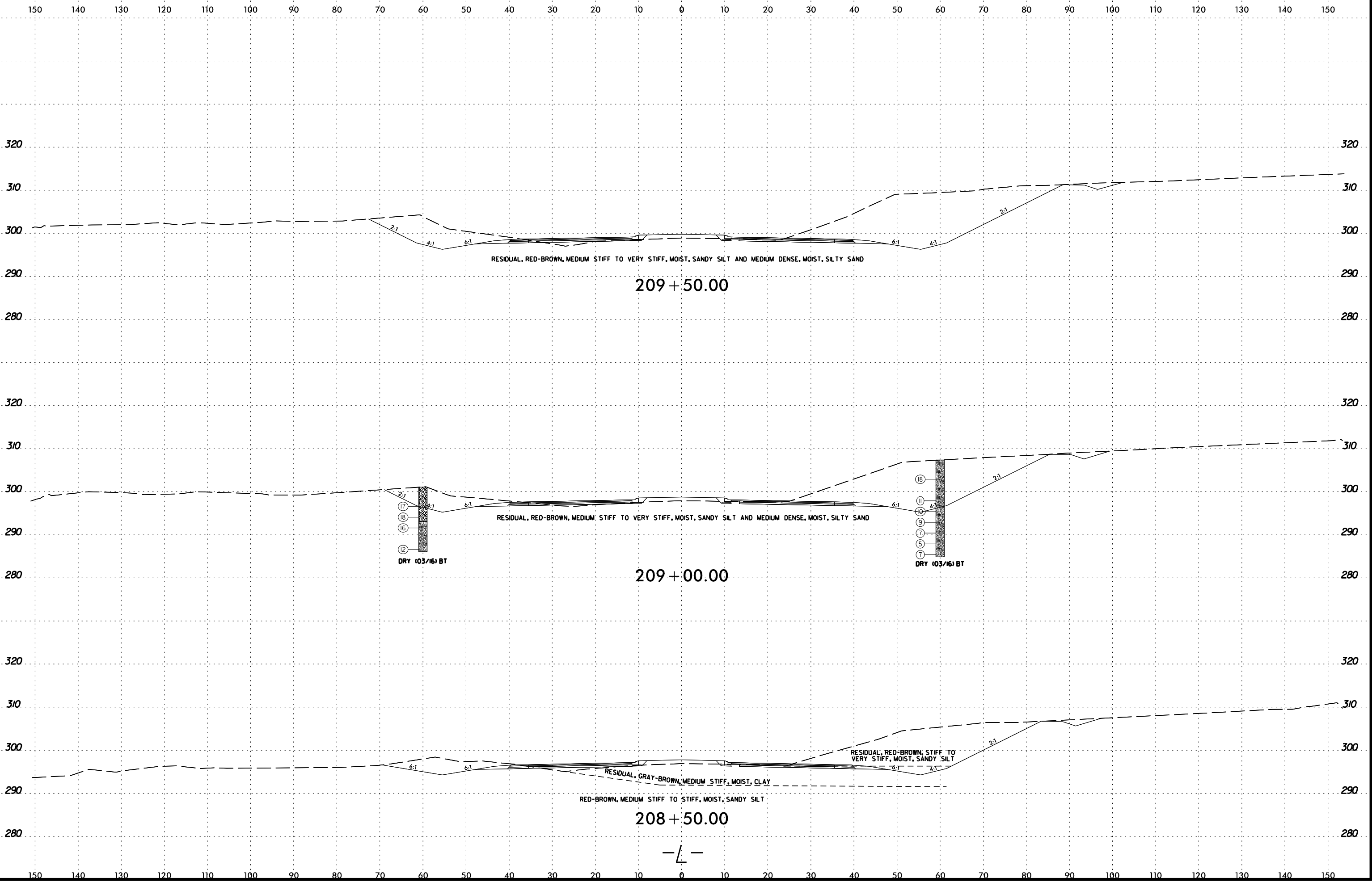

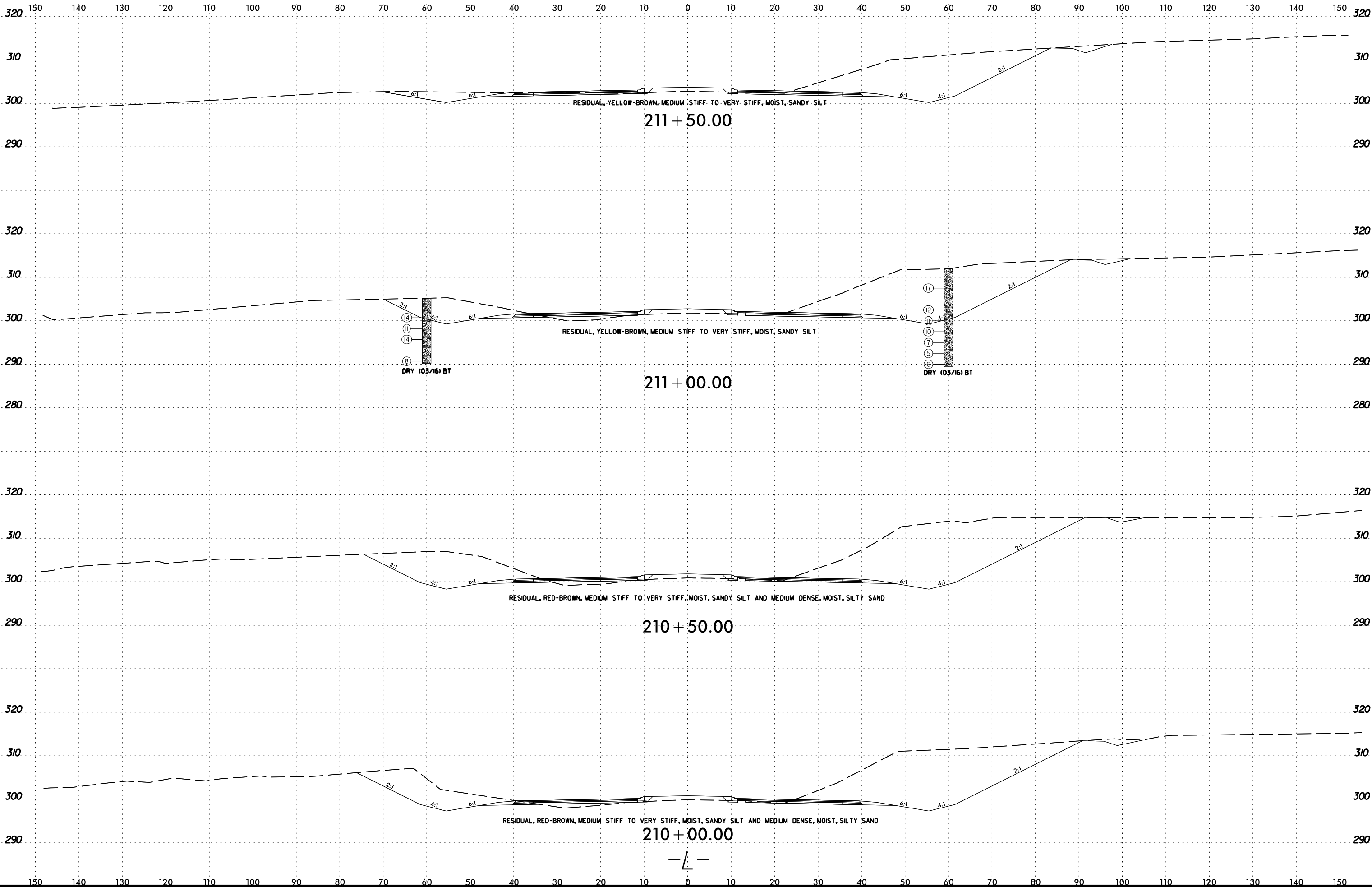

2/23/2017  
 C:\Users\mington\OneDrive\Documents\R-3825B\RDWY\modif\ter\CA00D\_GEO1TECH\sc\R3825B\_Geo\_xsl.1.166+50+257+70.dgn

6/23/16

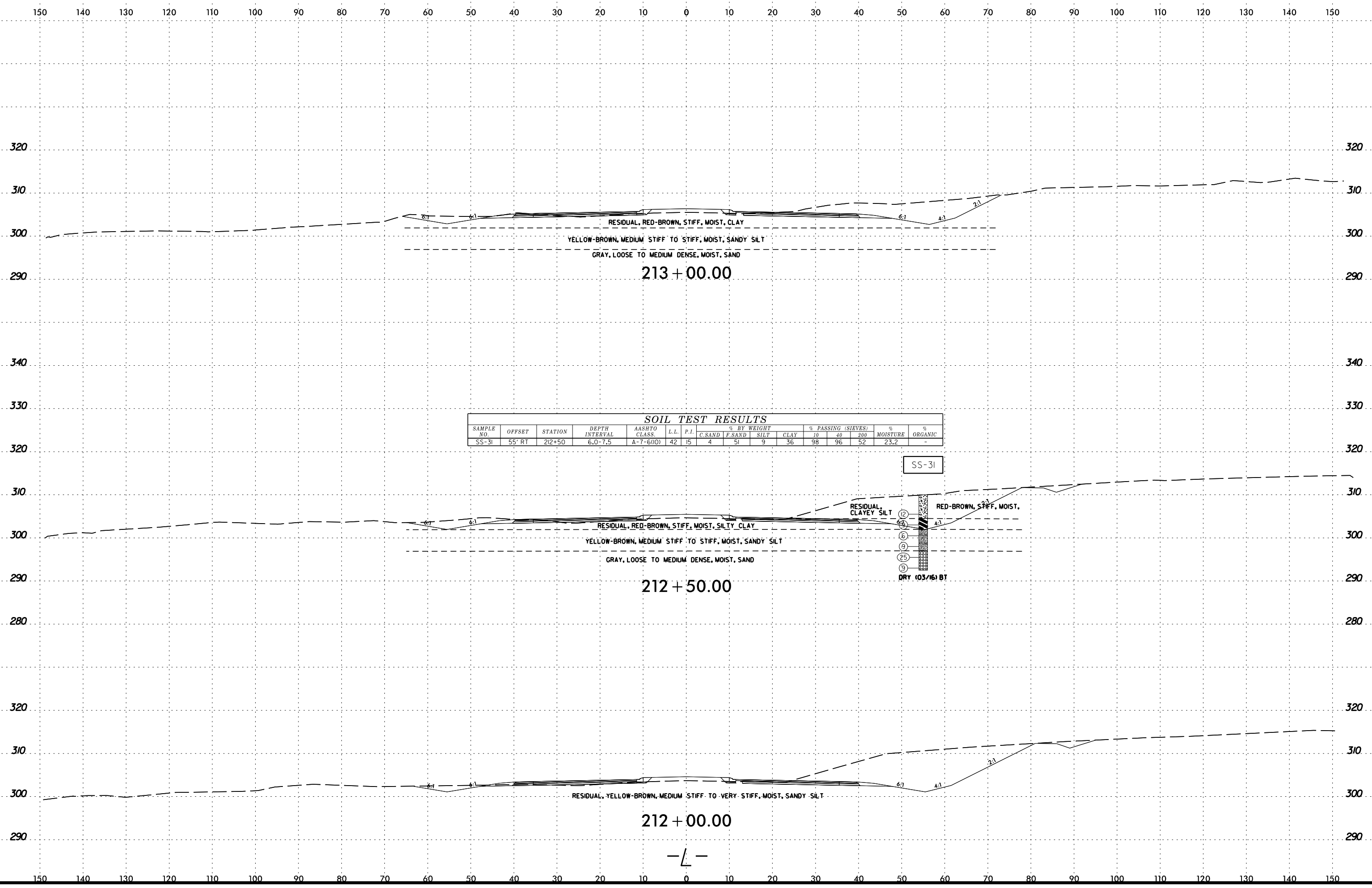

2/23/2017  
M:\N\NCD01\R-3825B-R-3825B-Geo.RDWM.modifier\CA00.GEOTECH\sc\R3825B\_Geo.xsl.1.166+50-257+70.dgn

6/23/16

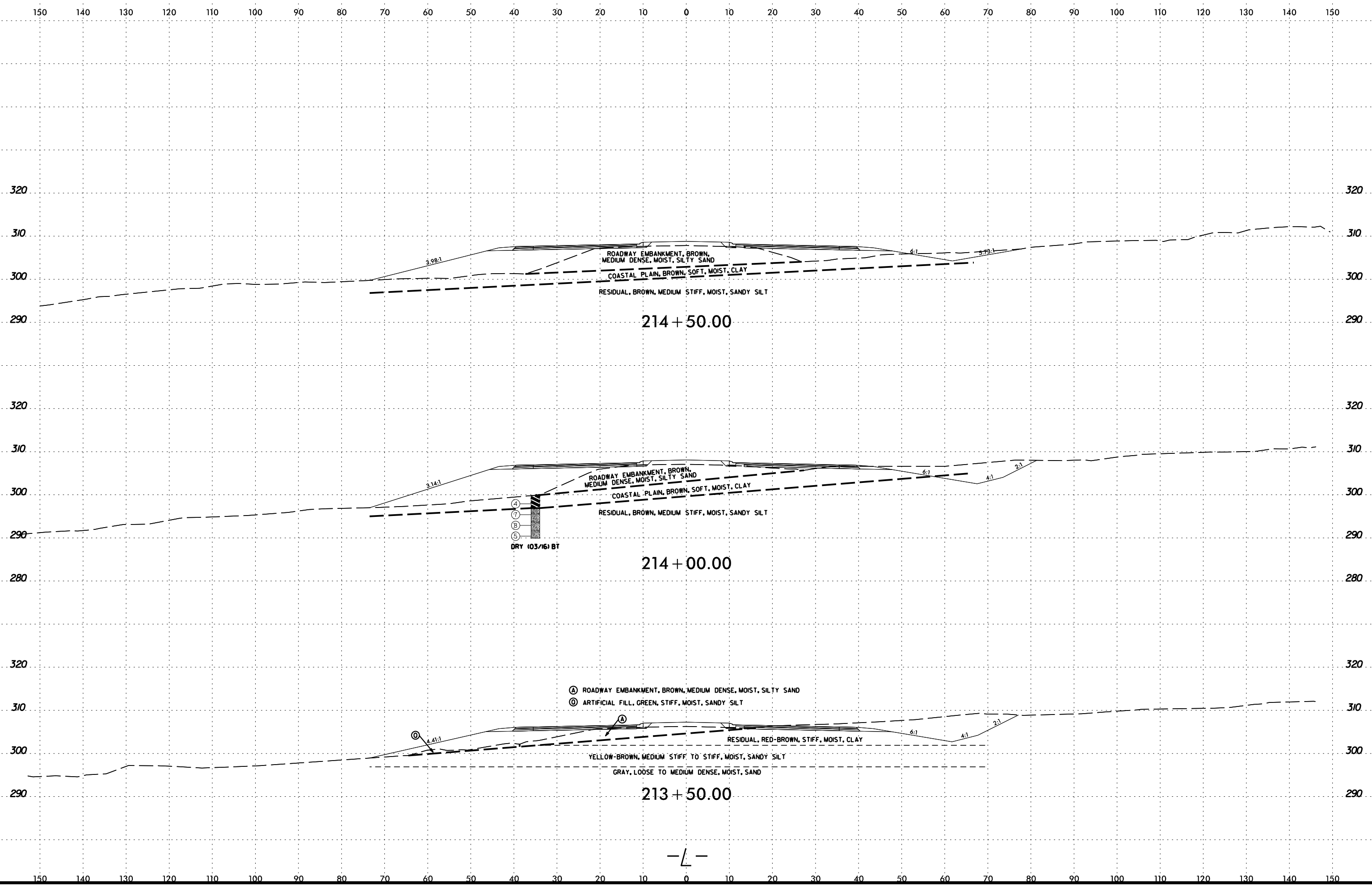

2/23/2017  
 M:\N\NCD01\R-3825B\GEO.\RDWY.mxd  
 C:\Users\imington

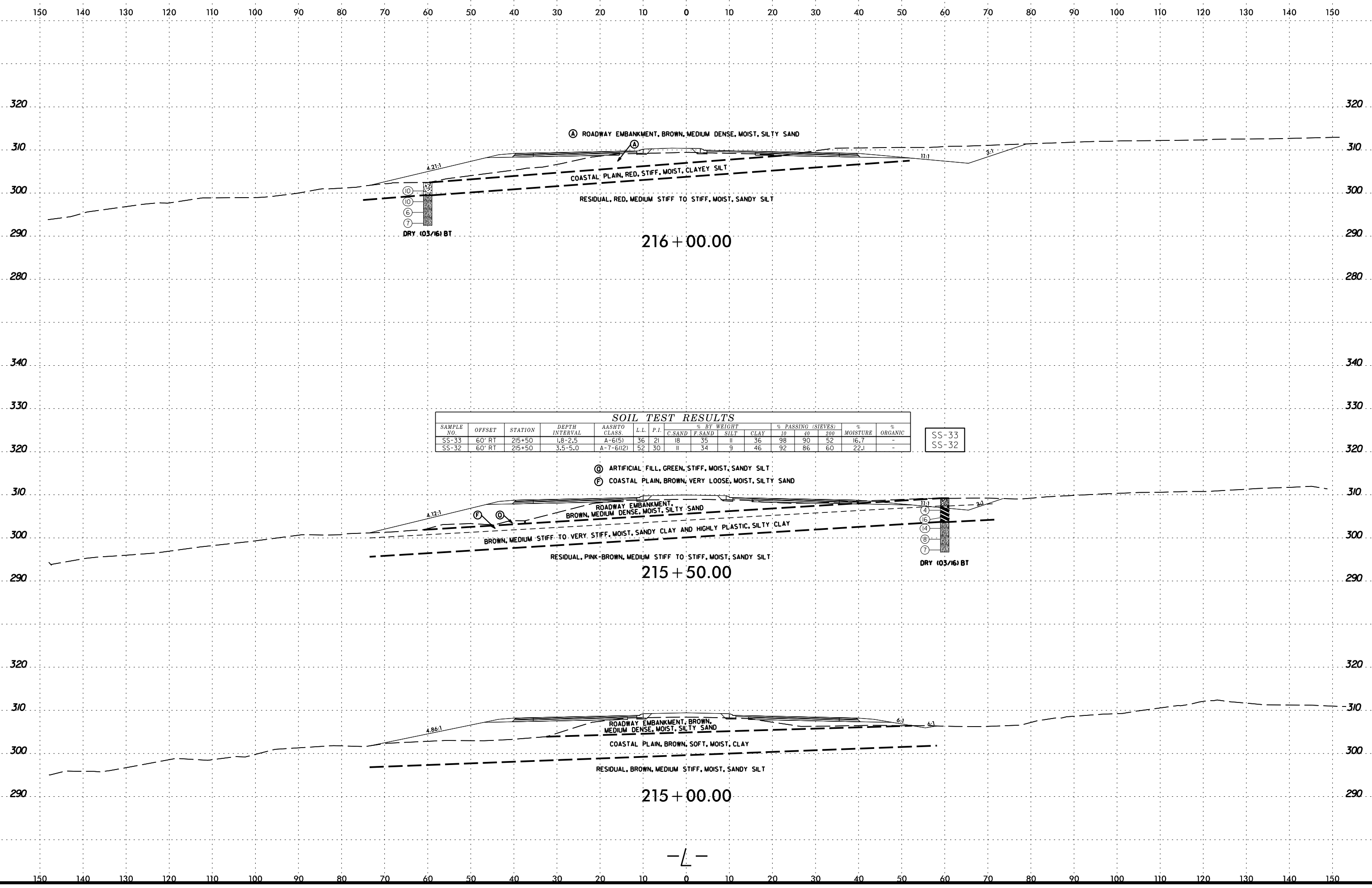

**SOIL TEST RESULTS**

SAMPLE NO.	OFFSET	STATION	DEPTH INTERVAL	AASHTO CLASS.	L.L.	P.I.	% BY WEIGHT			% PASSING (SIEVES)			% MOISTURE	% ORGANIC	
							C. SAND	F. SAND	SILT	CLAY	10	40			200
SS-33	60' RT	215+50	1.8-2.5	A-6(5)	36	21	18	35	11	36	98	90	52	16.7	-
SS-32	60' RT	215+50	3.5-5.0	A-7-6(12)	52	30	11	34	9	46	92	86	60	22.1	-

SS-33  
 SS-32

6/23/16

SAMPLE NO.	OFFSET	STATION	DEPTH INTERVAL	AASHTO CLASS.	L.L.	P.I.	% BY WEIGHT				% PASSING (SIEVES)			% MOISTURE	% ORGANIC
							C SAND	F SAND	SILT	CLAY	10	40	200		
SS-34	60' RT	217+50	3.5-5.0	A-6(2)	30	14	29	35	11	24	100	85	40	15.8	-
SS-35	60' RT	217+50	6.0-7.5	A-2-7(1)	44	24	33	45	5	17	97	82	29	17.8	-

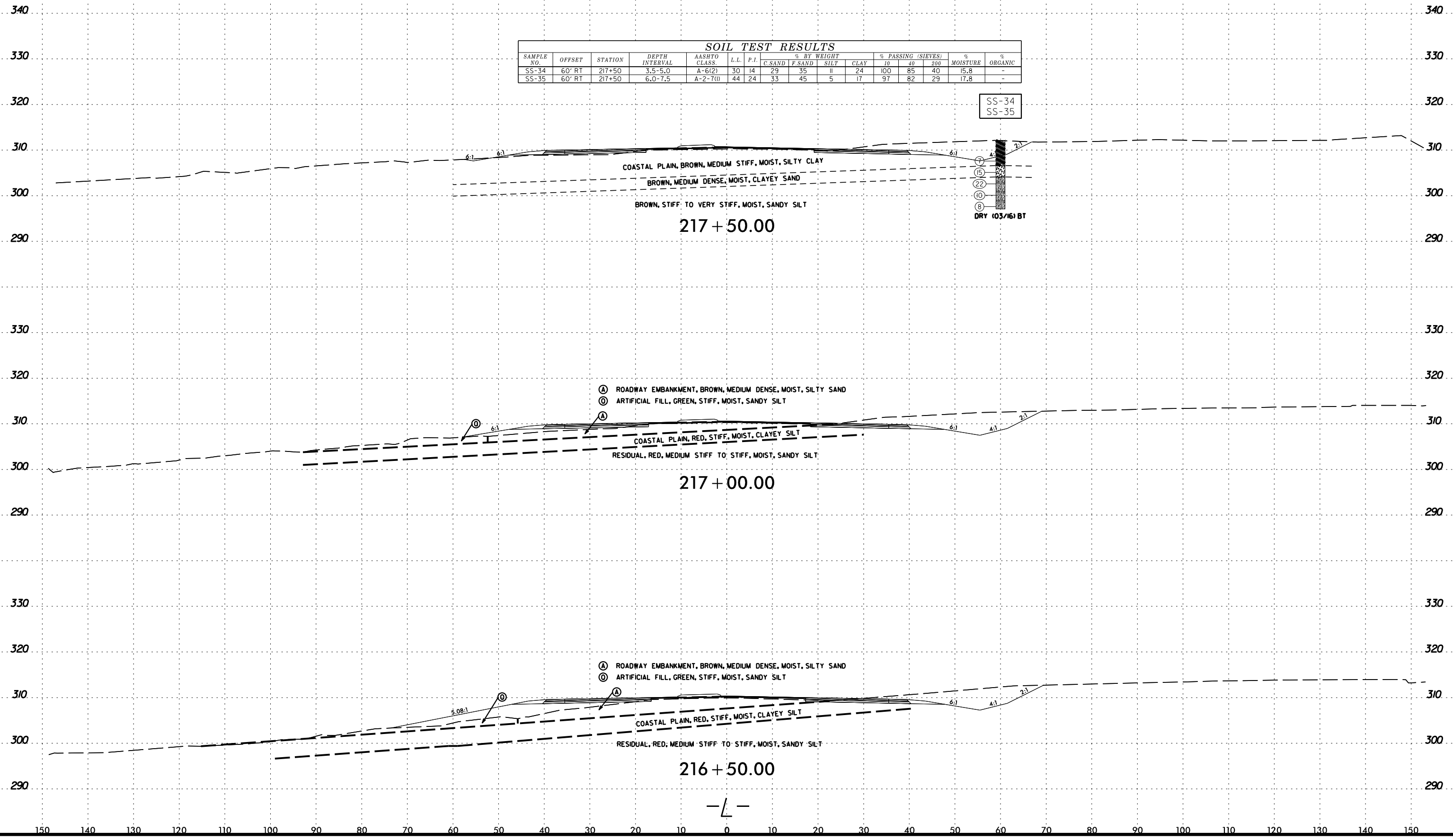

2/23/2017 11:58:00 AM C:\Users\mcc01\OneDrive\Documents\R-3825B\GEO\RDWY\modif\er\CA00\GEO\TECH\sc\R3825B\_Geo\_xsi.1.166+50-257+70.dgn

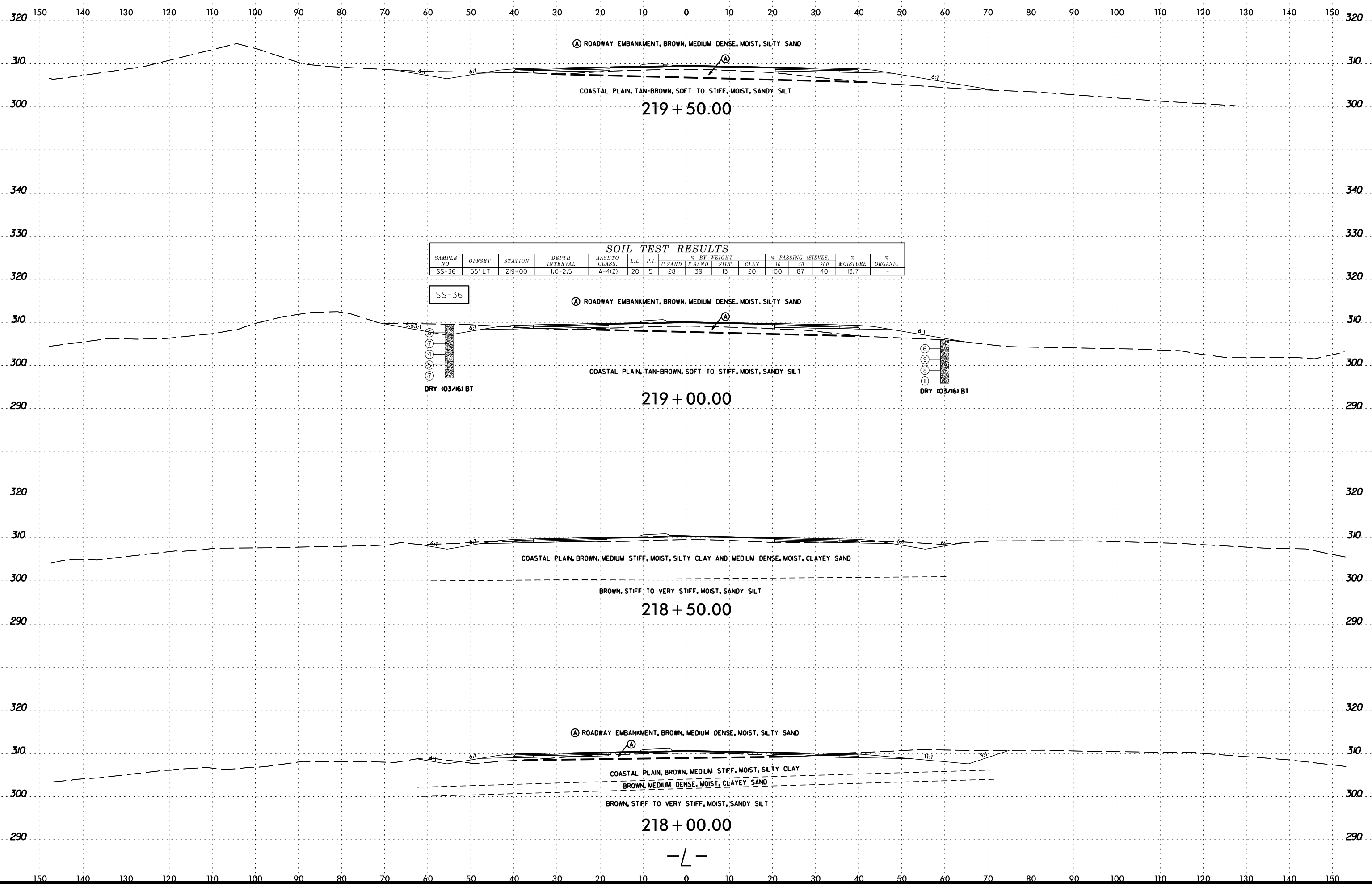

**SOIL TEST RESULTS**

SAMPLE NO.	OFFSET	STATION	DEPTH INTERVAL	AASHTO CLASS.	L.L.	P.I.	% BY WEIGHT				% PASSING (SIEVES)			% MOISTURE	% ORGANIC
							C SAND	F SAND	SILT	CLAY	10	40	200		
SS-36	55' LT	219+00	1.0-2.5	A-4(2)	20	5	28	39	13	20	100	87	40	13.7	-

SS-36

DRY (03/16) BT

DRY (03/16) BT

6/23/16

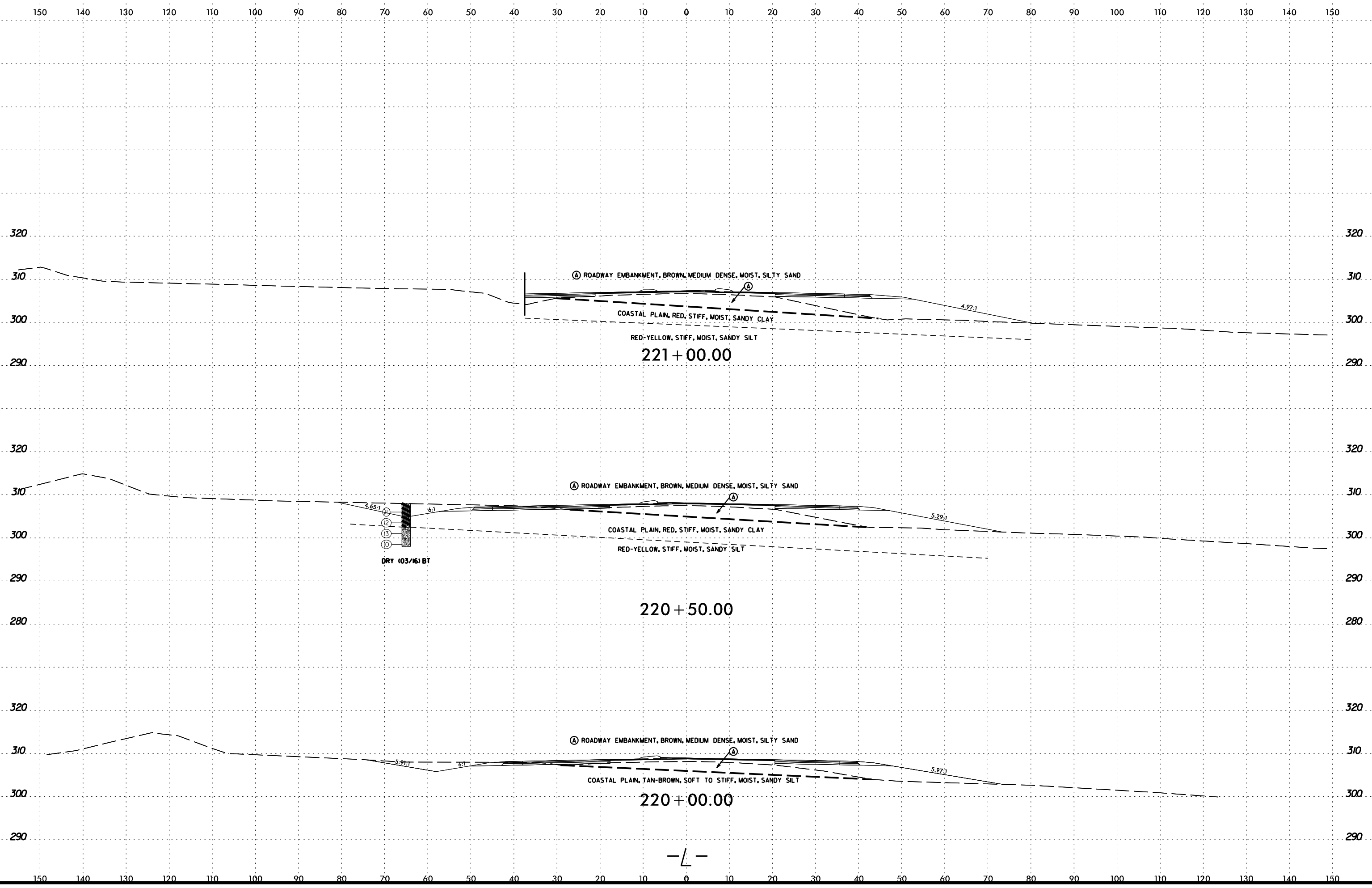

2/23/2017  
M:\N\CD01\R-3825B\GEO\_RDWY.mxd  
C:\Program Files\Autodesk\AutoCAD 2010\acad.lsp



SOIL TEST RESULTS															
SAMPLE NO.	OFFSET	STATION	DEPTH INTERVAL	AASHTO CLASS.	L.L.	P.I.	% BY WEIGHT				% PASSING (SIEVES)			% MOISTURE	% ORGANIC
							C.SAND	F.SAND	SILT	CLAY	10	40	200		
SS-37	60' RT	222+50	1.0-2.0	A-2-4(10)	12	NP	36	43	14	7	100	83	26	7.7	-
SS-38	60' RT	222+50	2.0-2.5	A-2-4(10)	17	3	42	32	10	16	100	74	31	10.3	-
SS-39	60' RT	222+50	3.5-5.0	A-2-6(10)	28	11	32	38	9	21	99	82	35	16.0	-

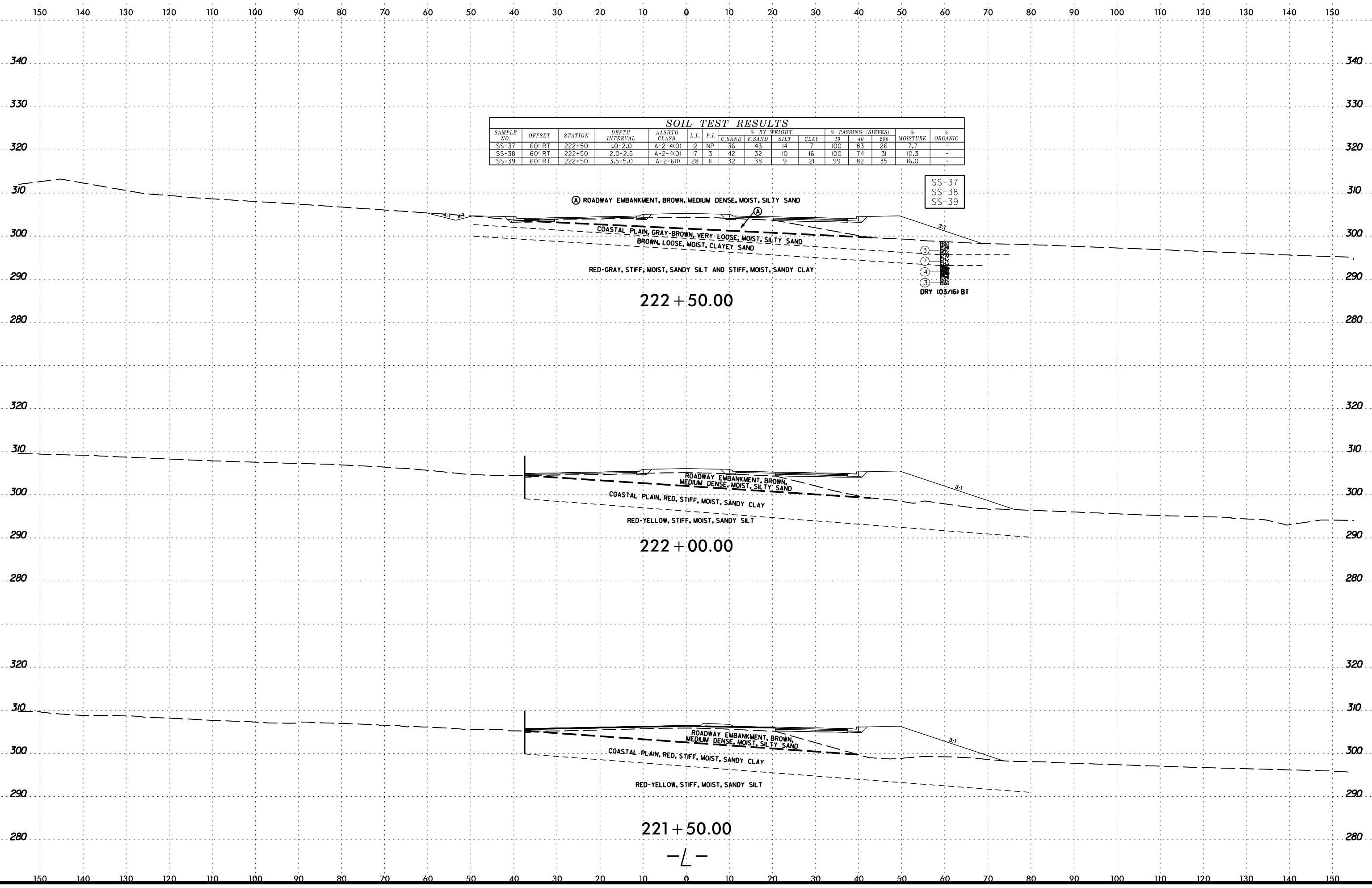

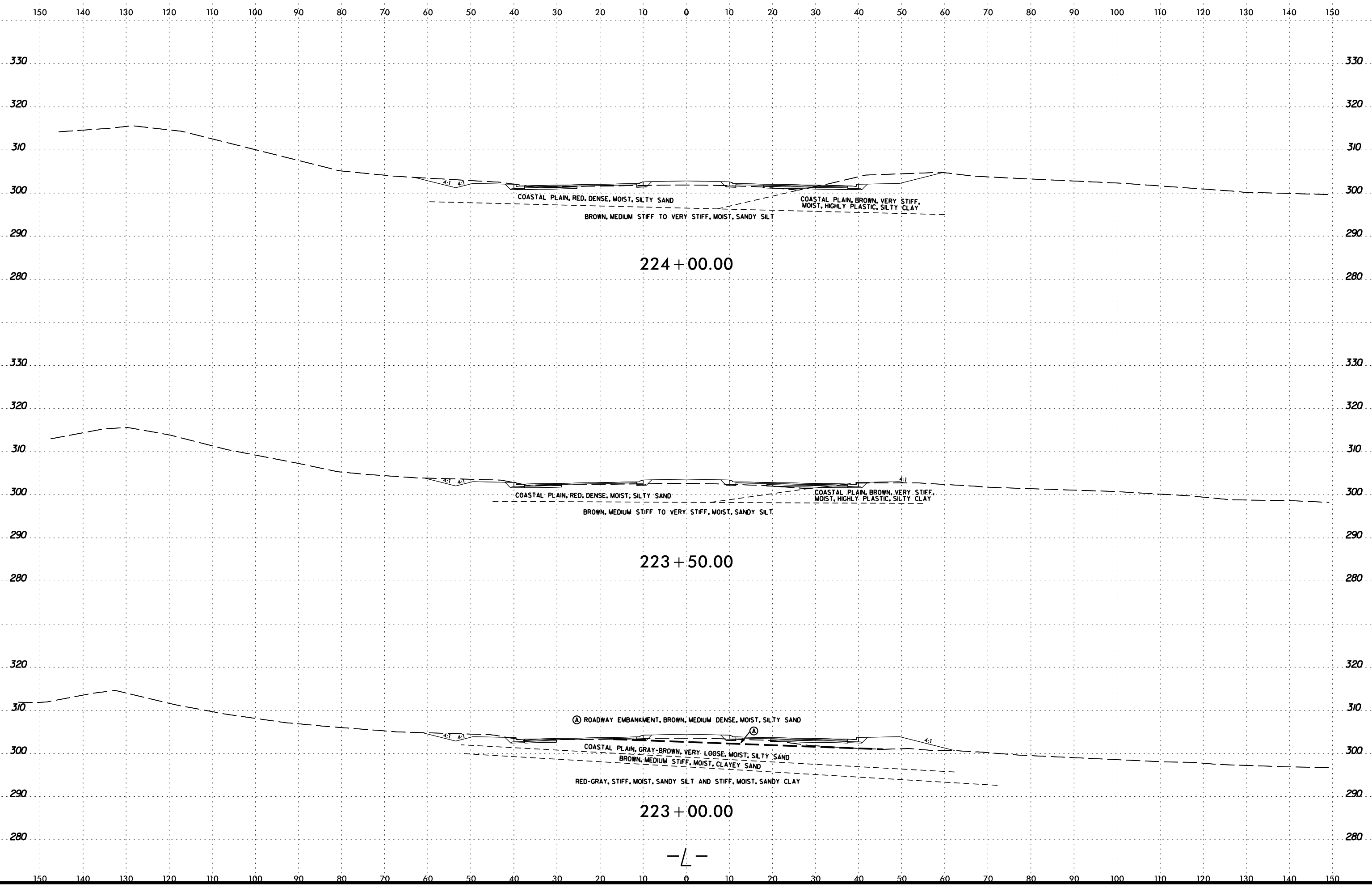



6/23/16  
2/23/2017  
C:\Users\mcc01\OneDrive\Documents\Projects\2017\20170223\20170223.dgn

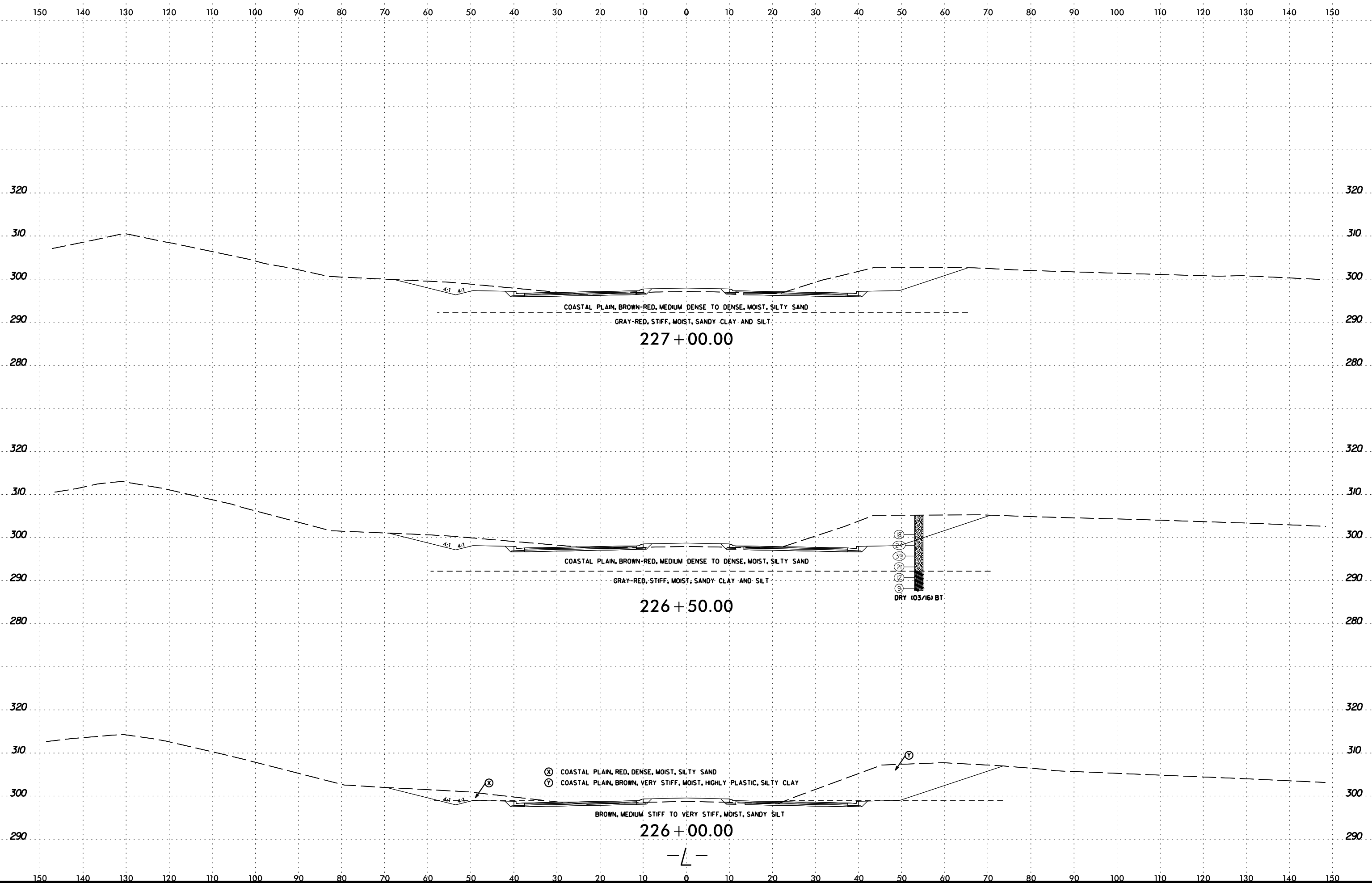



6/23/16

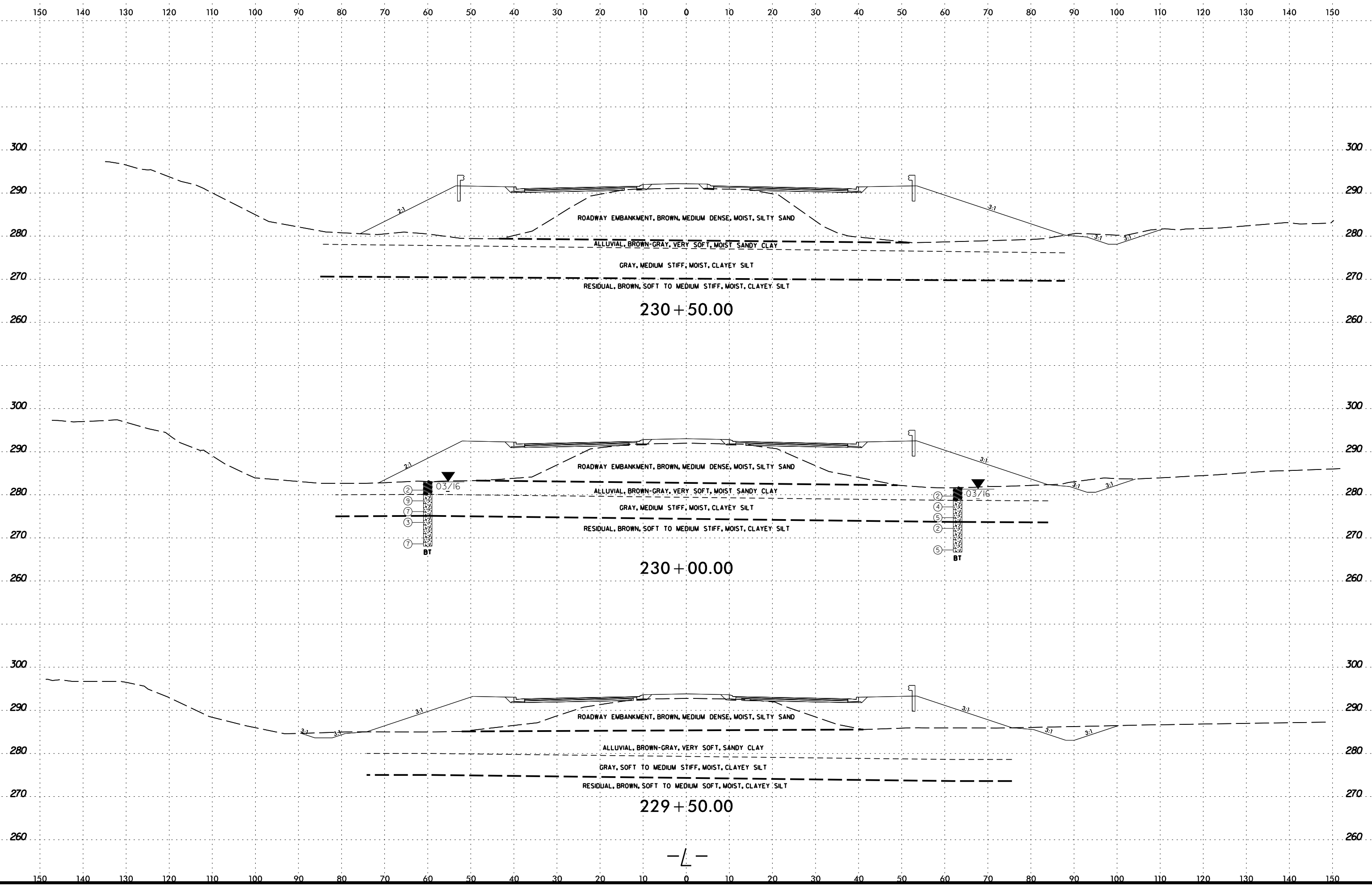

2/23/2017  
M:\N\CD01\R-3825B\R-3825B.GEO.RDWY.modifier\CA00.GEOTECH\sc\R3825B\_Geo\_xsi.1.166+50+257+70.dgn



6/23/16

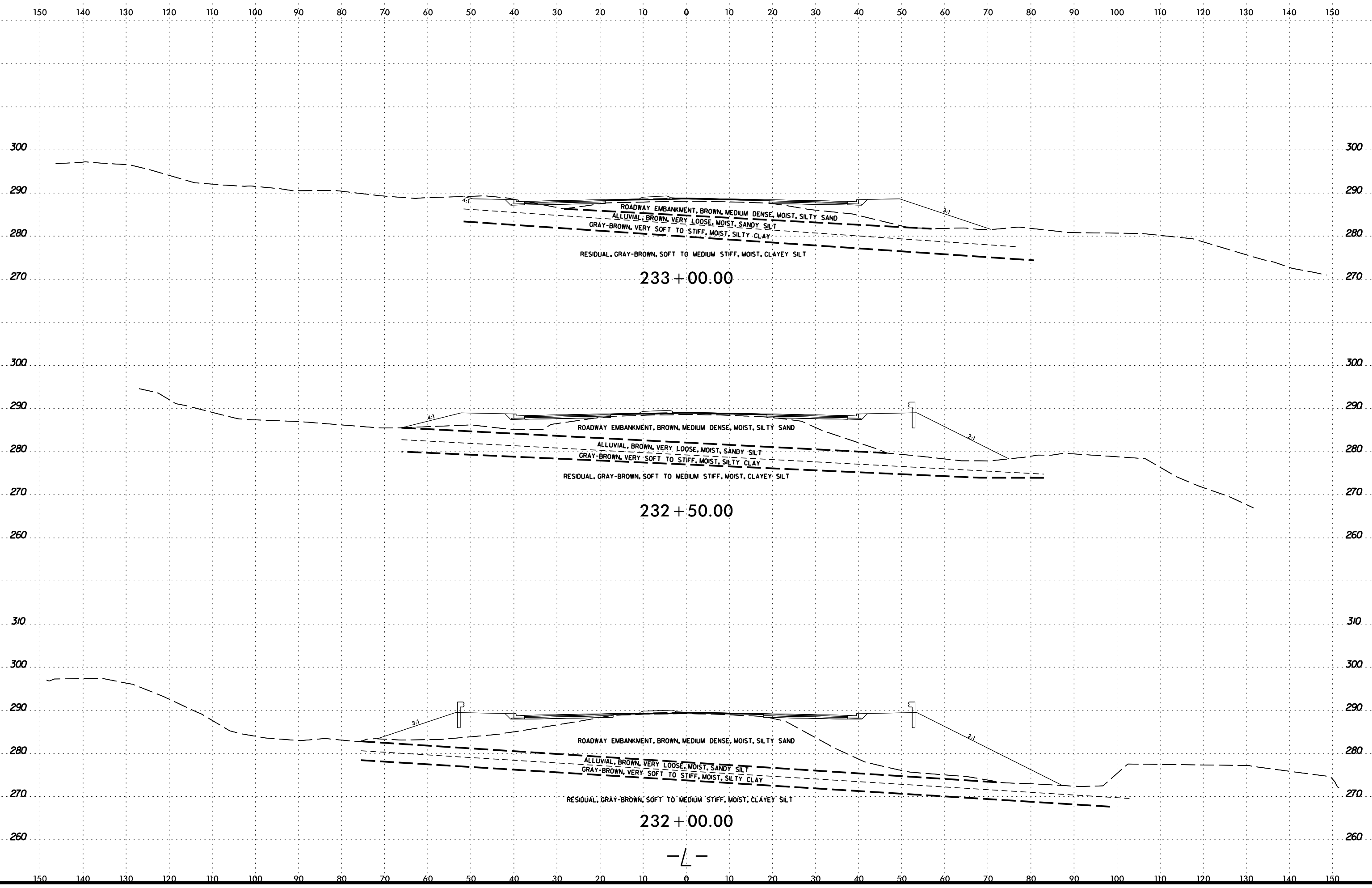

2/23/2017 2:51:00 PM C:\Users\mcc01\OneDrive\Documents\R-3825B\RDWY.mxd\fig\CA00.GEOTECH\sc\R3825B\_Geo\_xsi.1.166+50-257+70.dgn



6/23/16

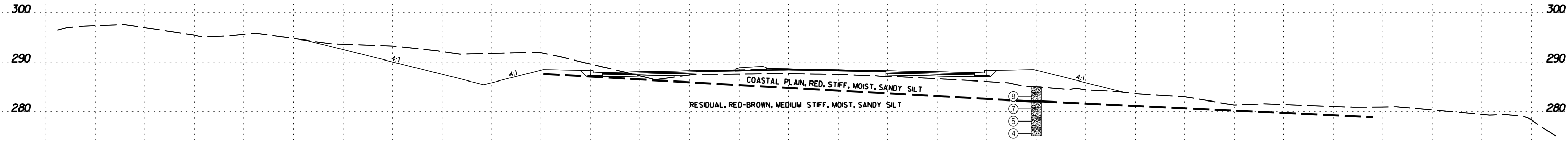
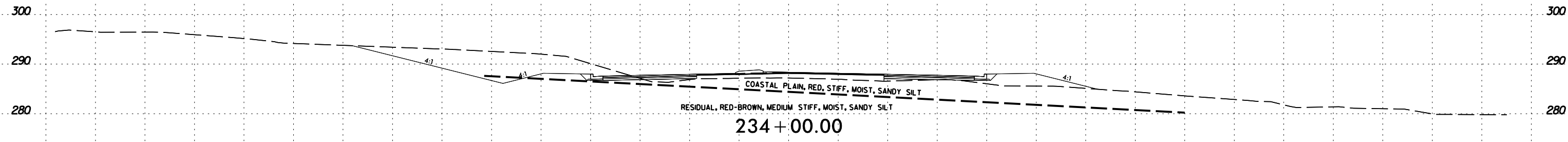
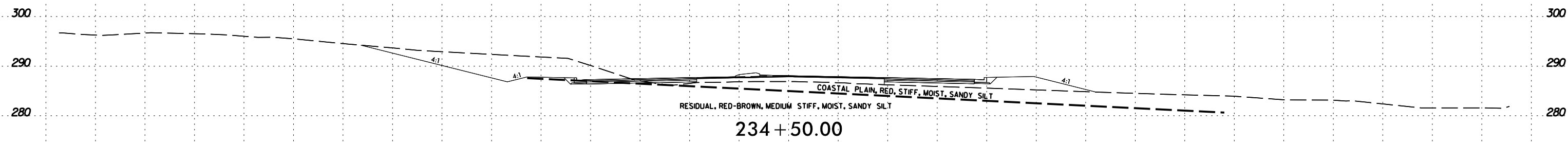
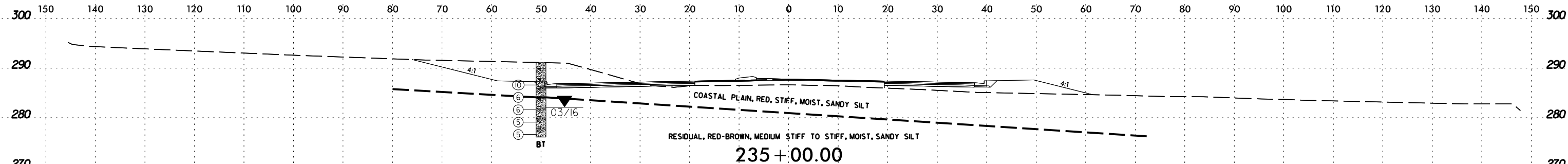

2/23/2017 2:55:11 PM C:\Users\mcc01\OneDrive\Documents\R-3825B\GEO\RDWY\modif\ter\CA00\_GEO1\TECH\sc\R3825B\_Geo\_xsi.1.166+50-257+70.dgn

-L-

6/23/16

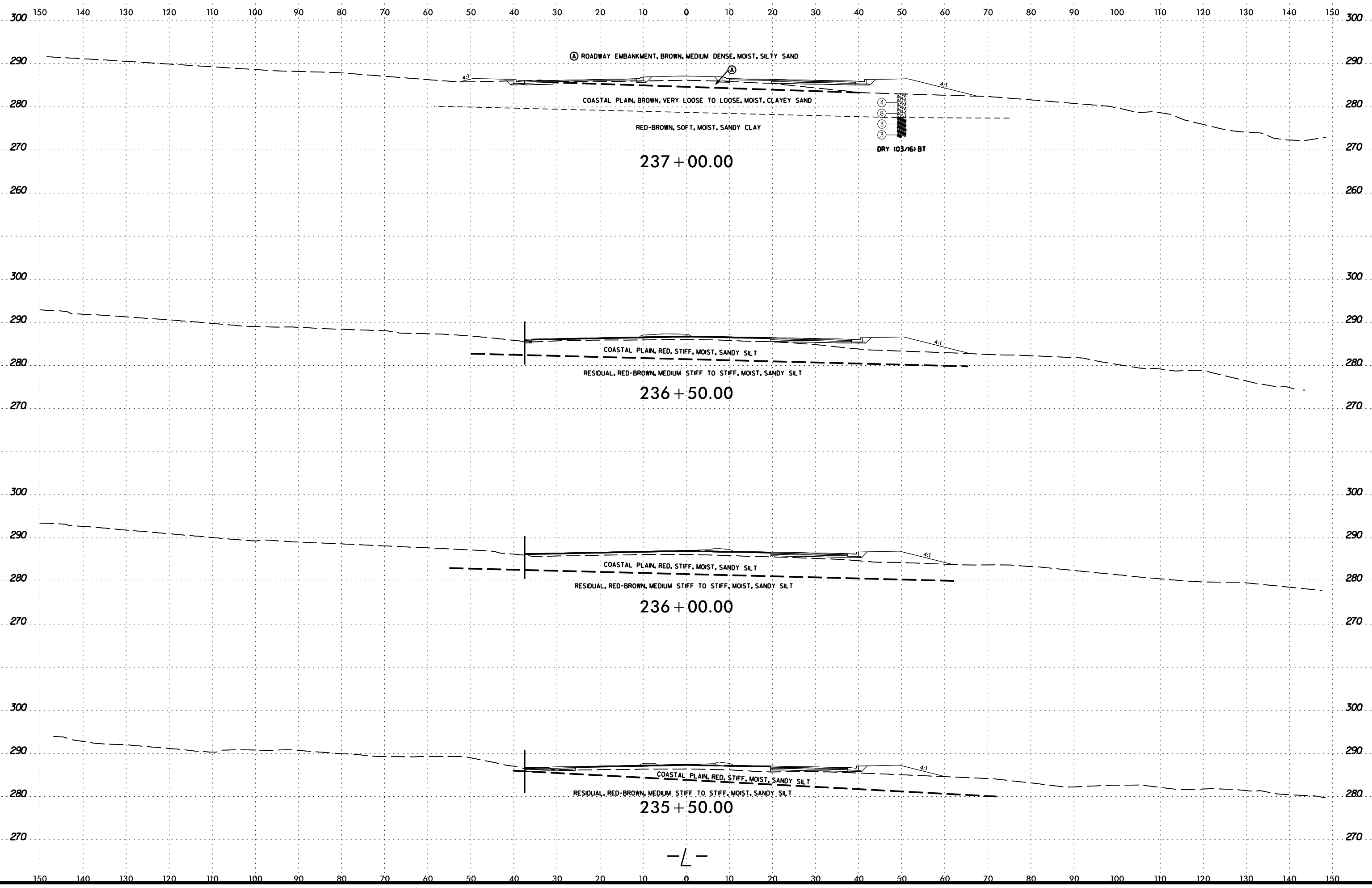

2/23/2017  
M:\N\CD01\R-3825B\GEO.\RDWY.mxd  
C:\Program Files\Autodesk\AutoCAD 2010\AutoCAD.exe

6/23/16

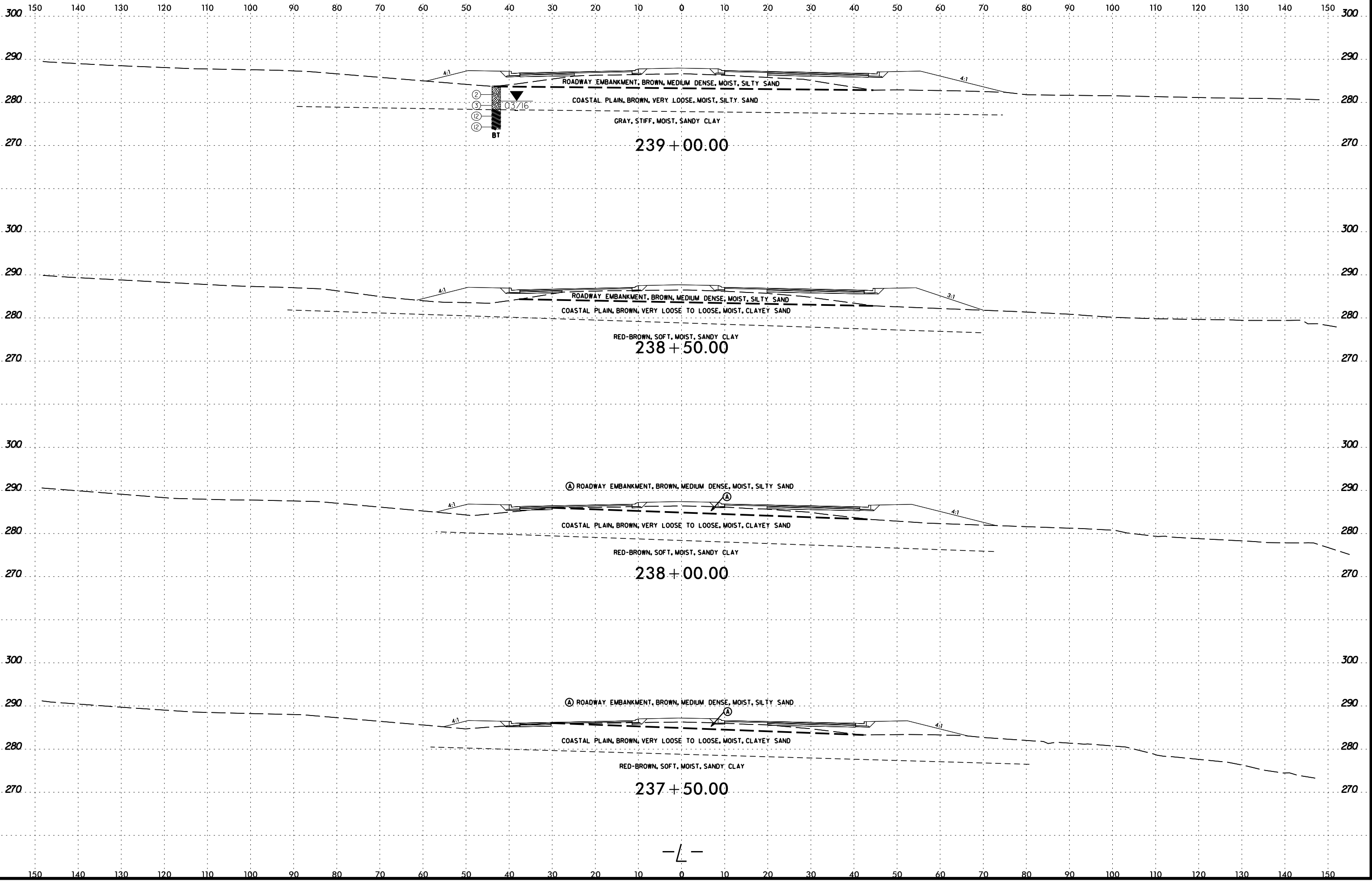

2/23/2017  
M:\N\CD01\R-3825B\R-3825B\_GEO\_RDWY.mxd  
C:\Program Files\Autodesk\AutoCAD 2017\MapTools\MapTools.exe

6/23/16

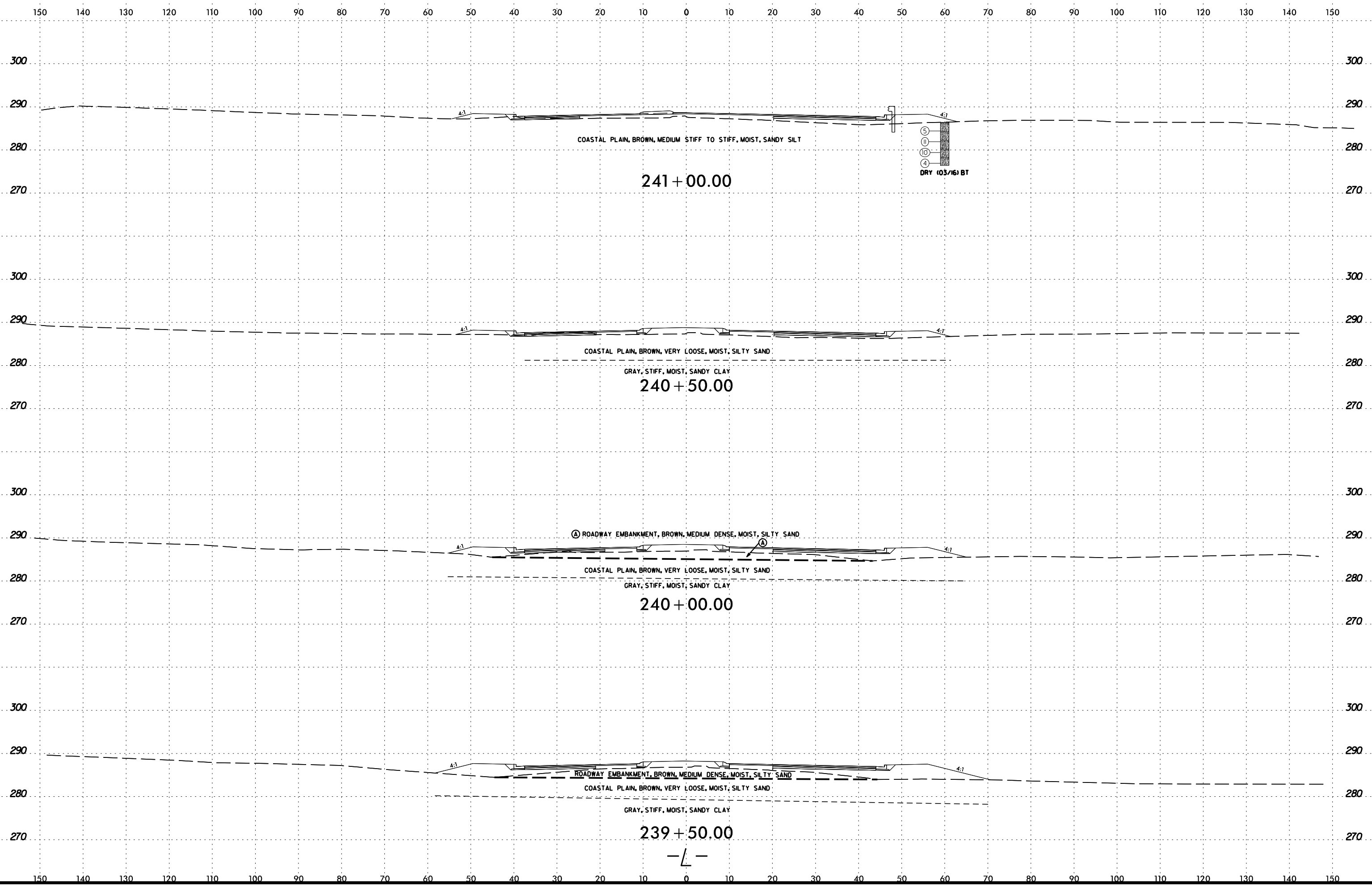

2/23/2017 2:51:11 PM C:\Users\mcc01\OneDrive\Documents\R-3825B\Geo\RDWY.mxd\modif\ter\CA00D.GEOTECH\sc\R3825B\_Geo\_xsl.1.166+50-257+70.dgn

6/23/16

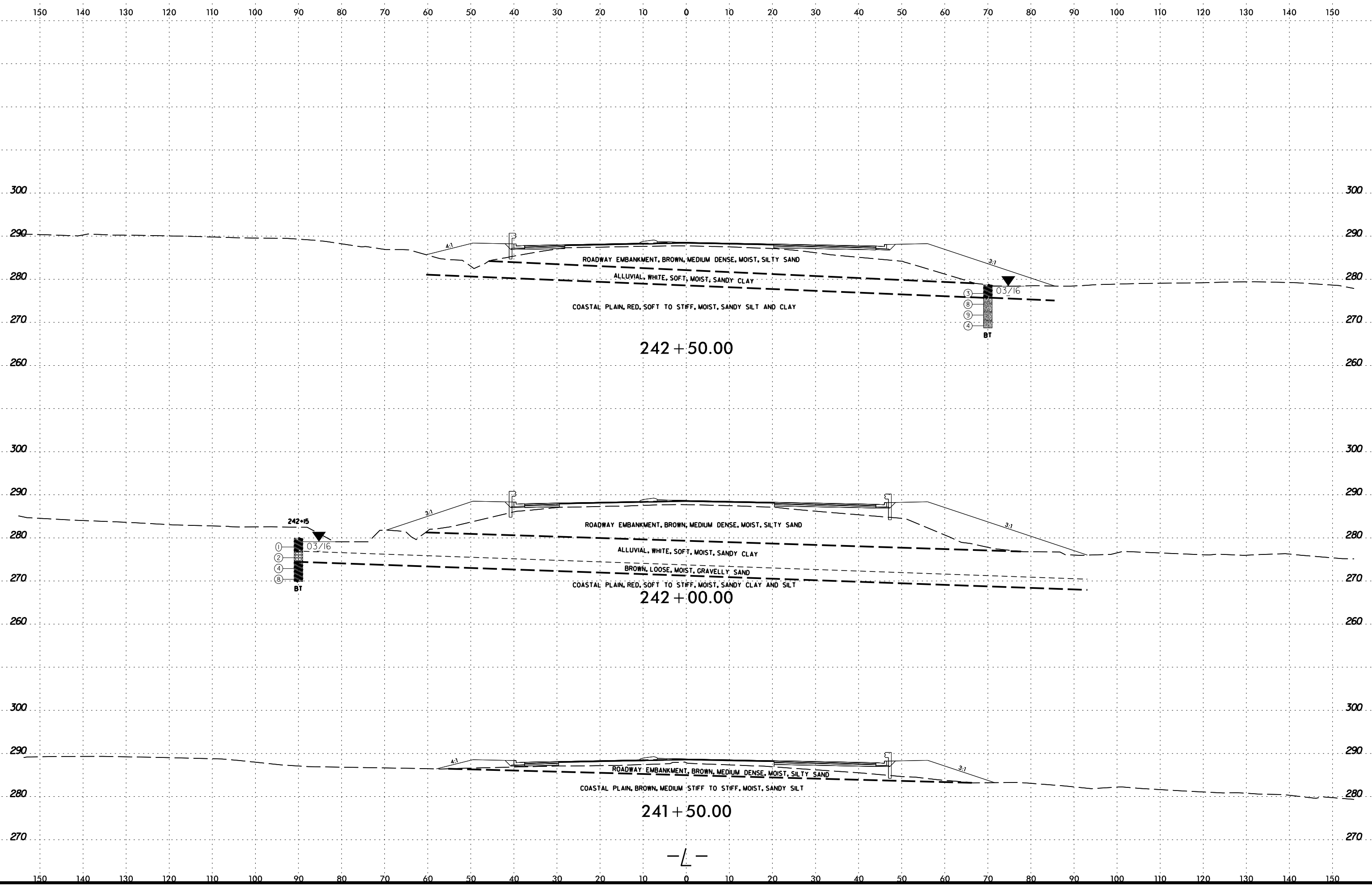

2/23/2017  
C:\Users\mcc01\OneDrive\Documents\R-3825B\GEO.RDWAY.mxd\Geo.r3825B.Geo.xsl.1.166+50-257+70.dgn

6/23/16

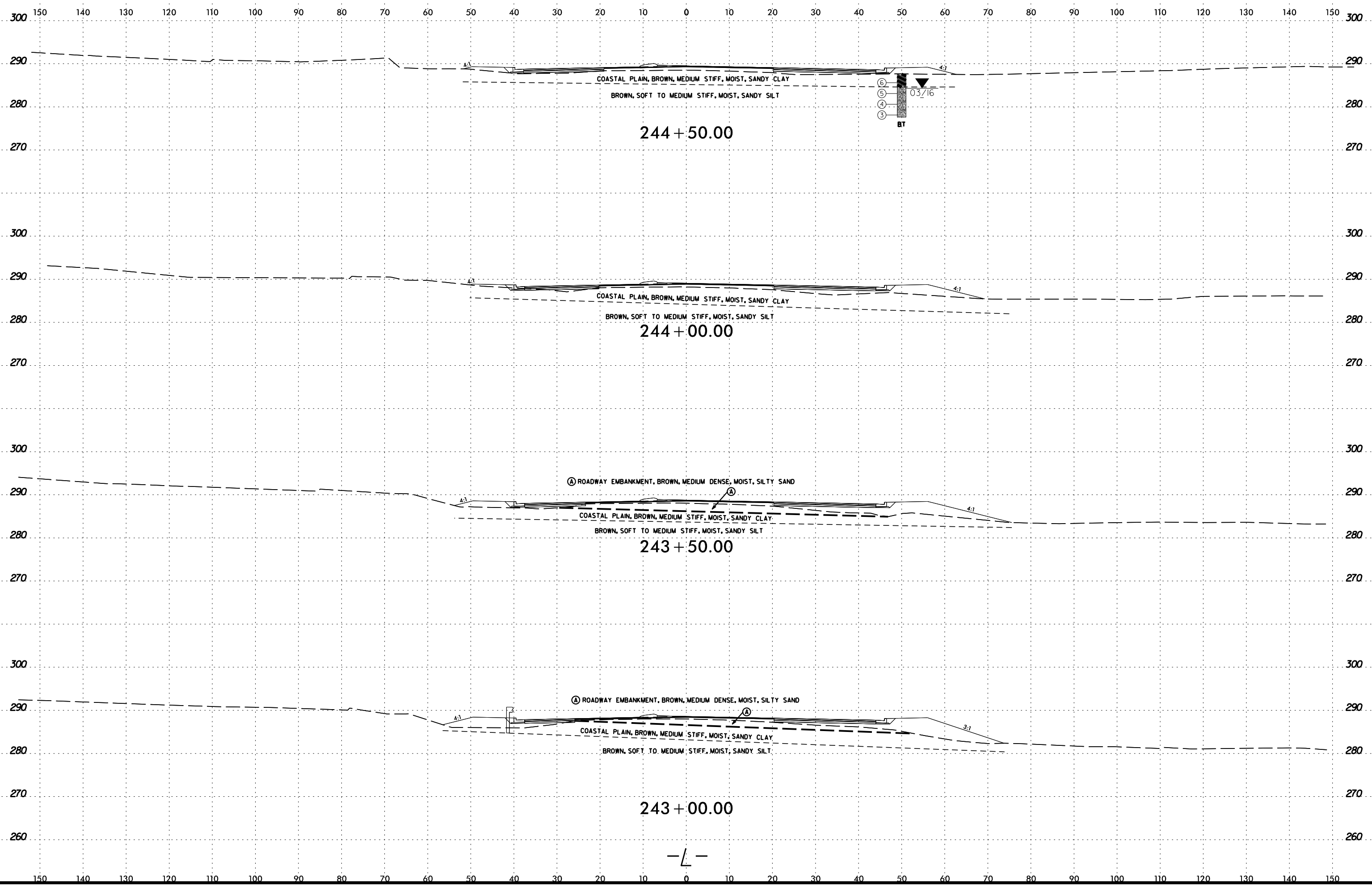

2/23/2017  
M:\N\CD01\R-3825B\R-3825B.GEO\_RDWY.mxd  
C:\Program Files\Autodesk\AutoCAD 2010\AutoCAD.exe

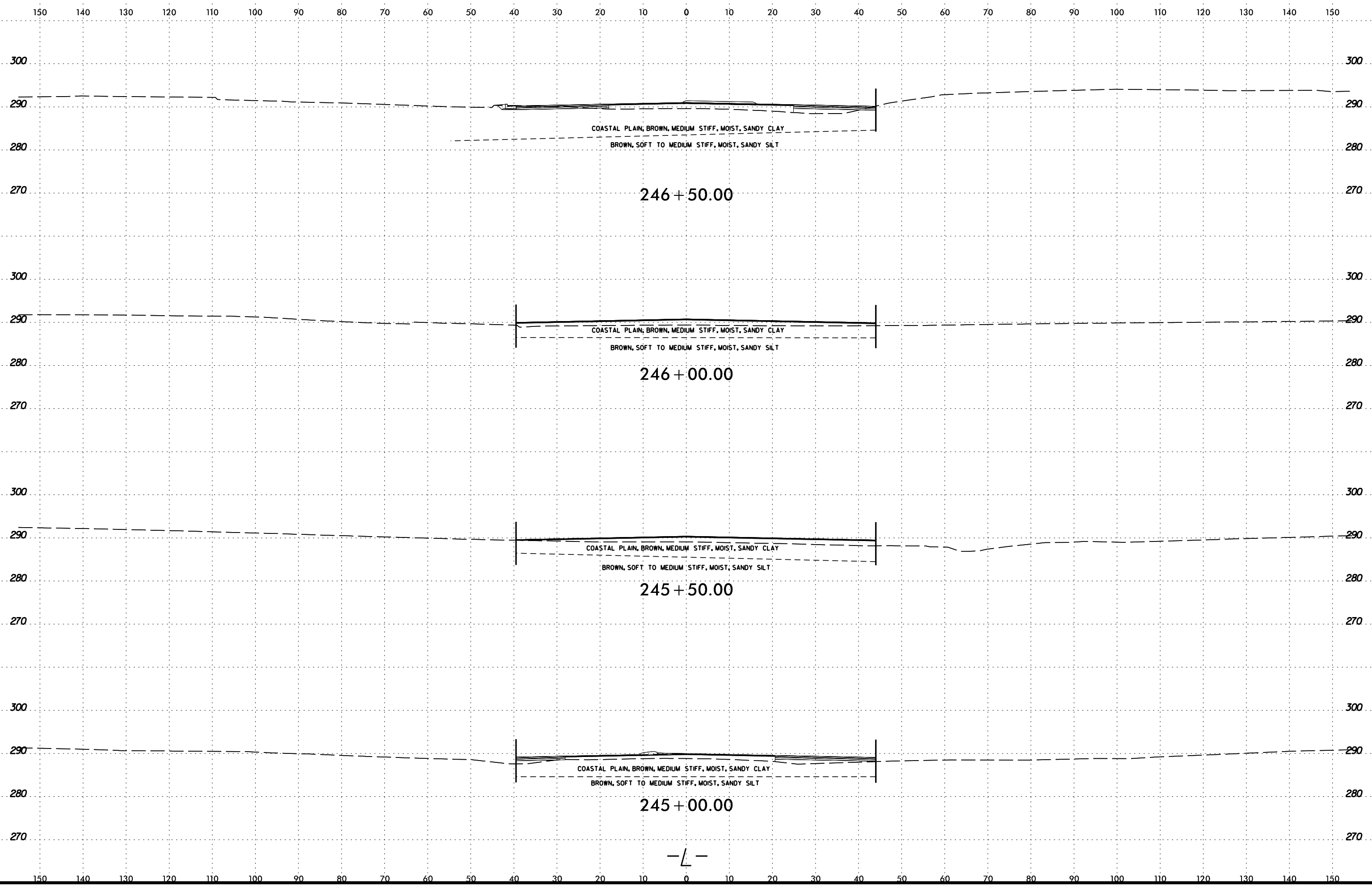

6/23/16

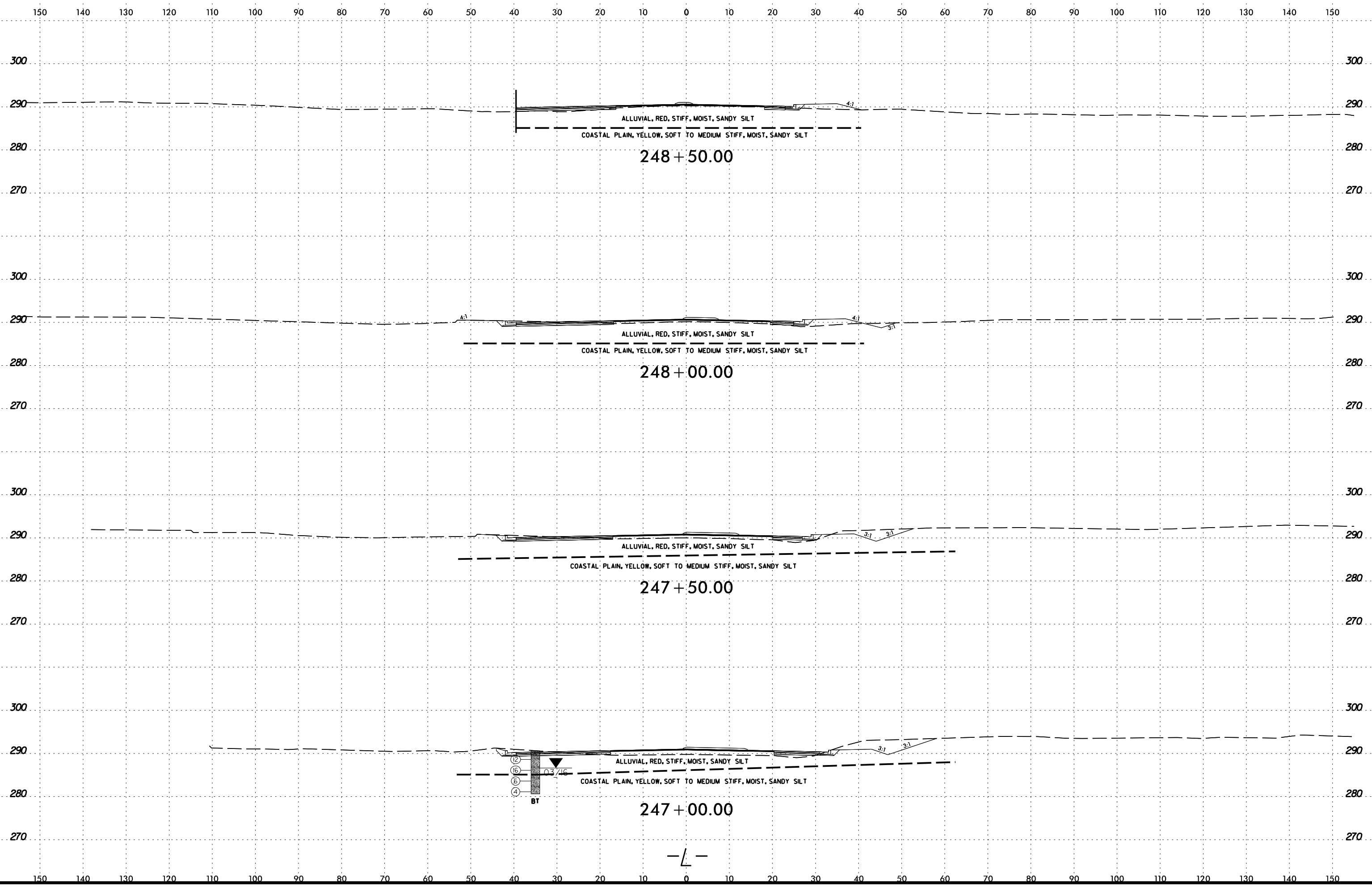

2/23/2017  
M:\N\NCD01\R-3825B\R-3825B.GEO...RDWY...modif\er\CA00D.GEOTECH\sc\R3825B\_Geo\_xsl.1.166+50+257+70.dgn



6/23/16

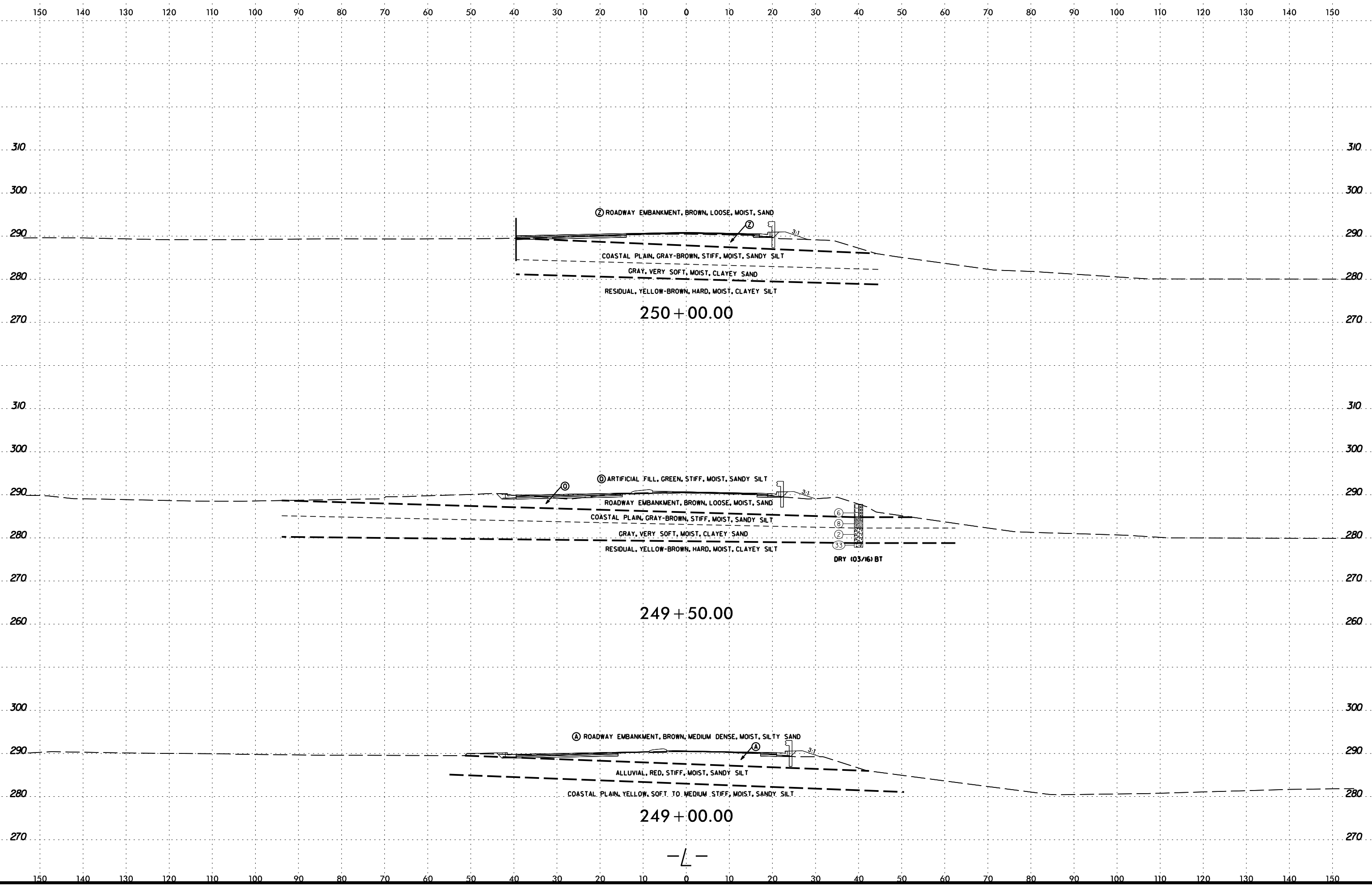

2/23/2017  
C:\Users\mcc01\OneDrive\Documents\Projects\2017\249+00.00\249+00.00.dgn



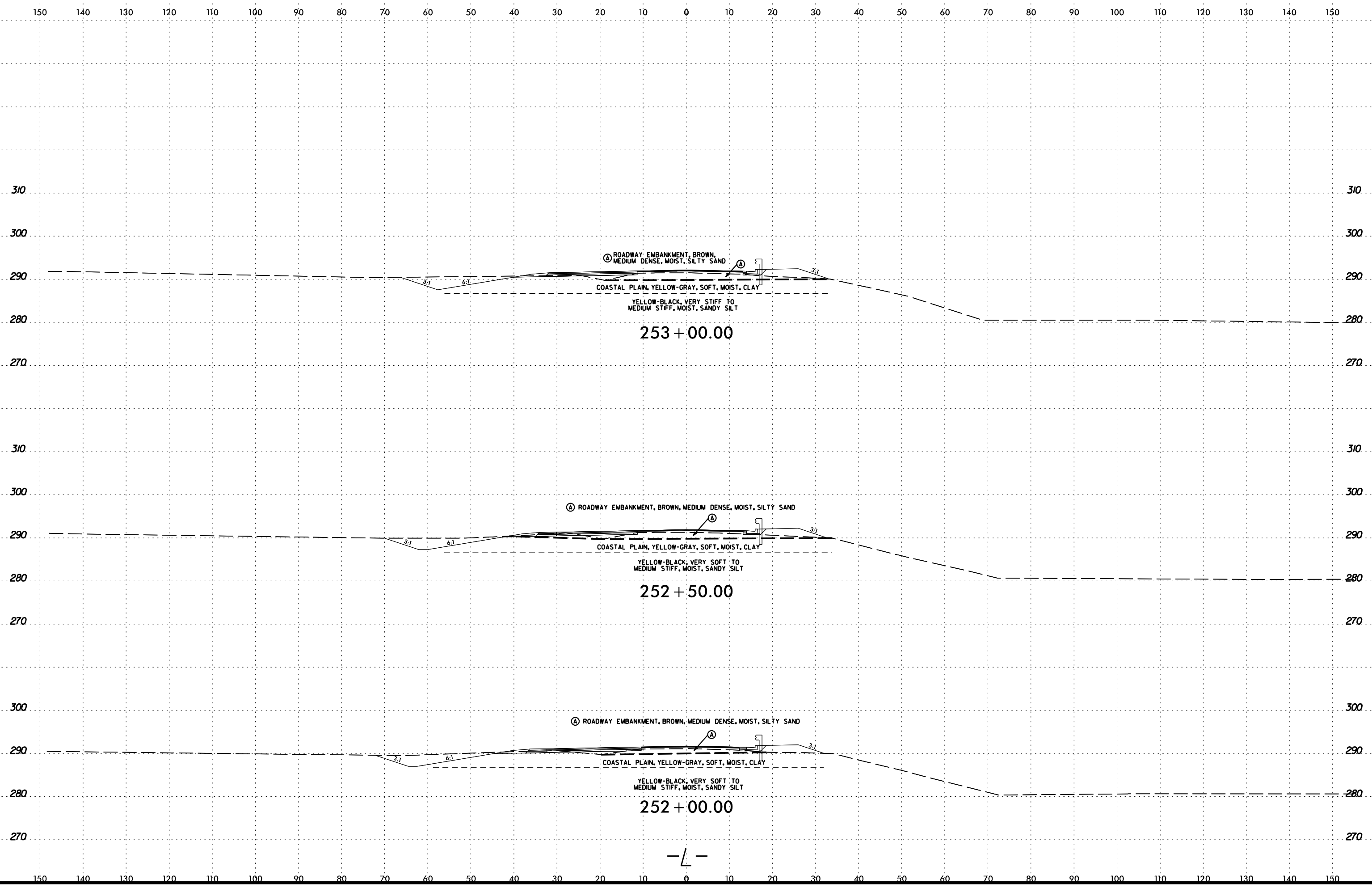

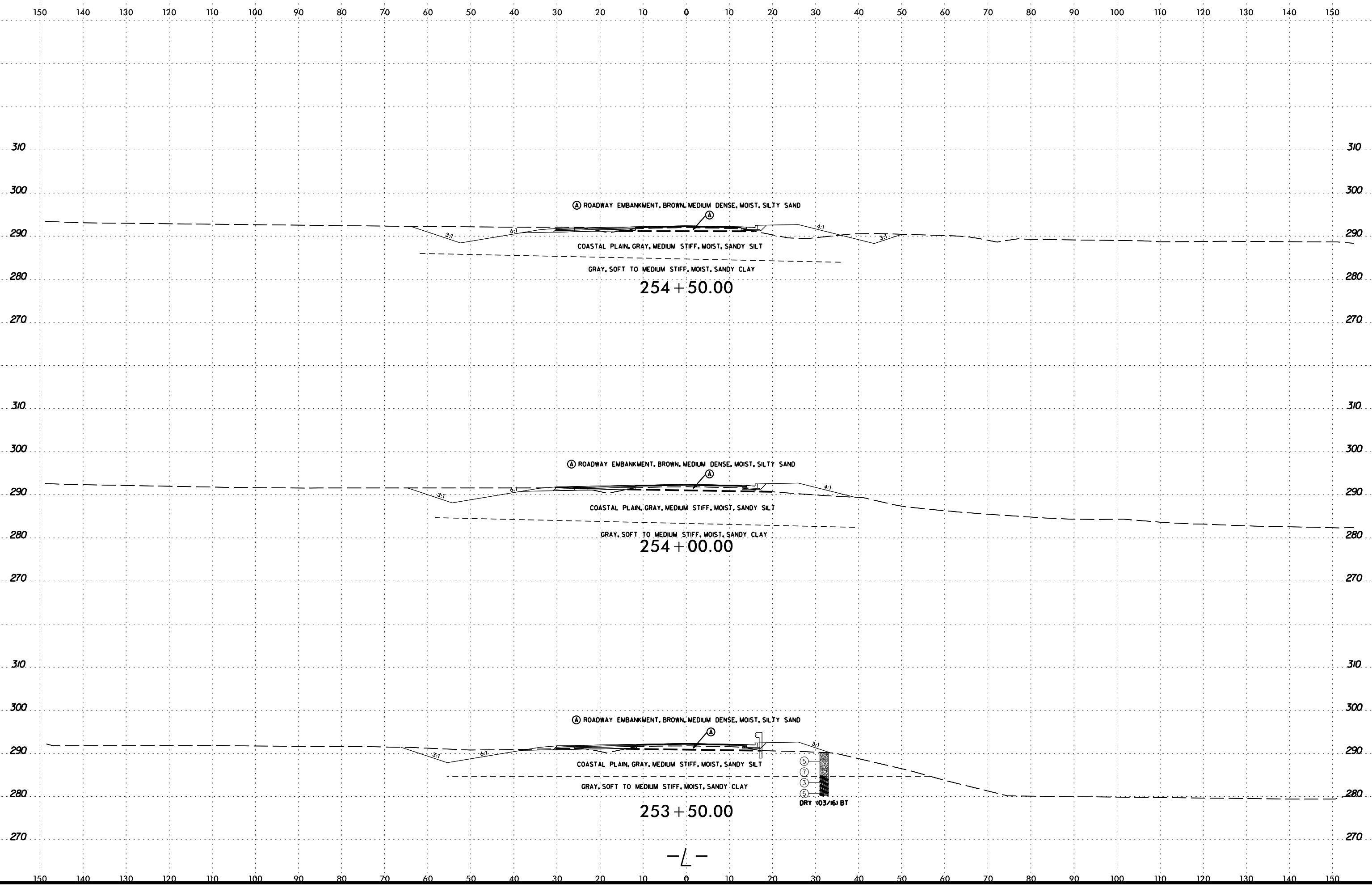

2/23/2017  
 M:\N\CD01\R-3825B\R-3825B.GEO.RDWY.mxd\ref\CA00.GEOTECH\sc\R3825B.Geo.xst.1.166+50-257+70.dgn  
 C:\ur\imgton

6/23/16

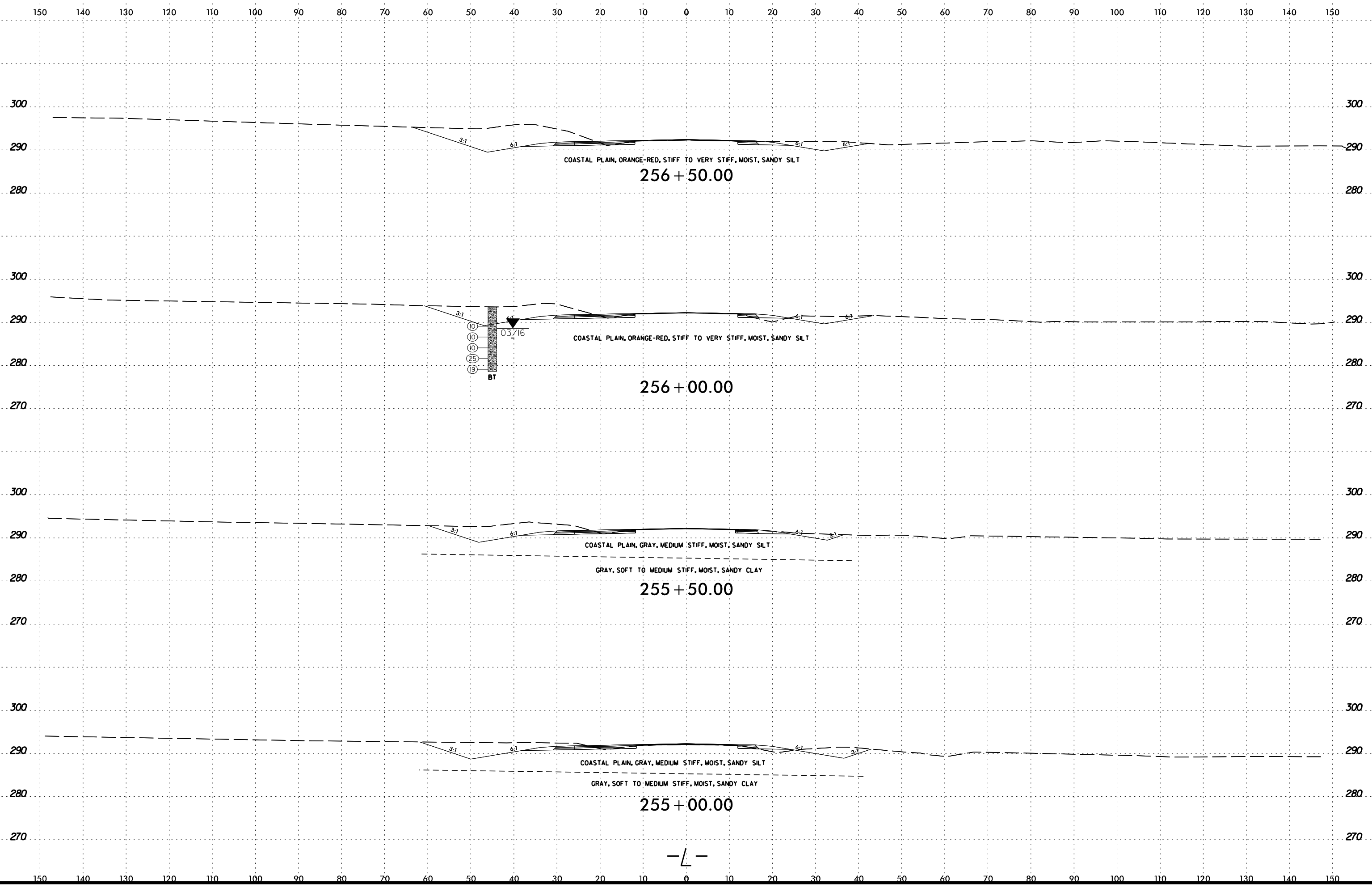

2/23/2017 11:58:00 AM C:\Users\mkington\OneDrive\Documents\Projects\3825B\3825B\_GEO\RDWY.mxd\3825B\_GEO\3825B\_GEO.dgn

- / -

6/23/16

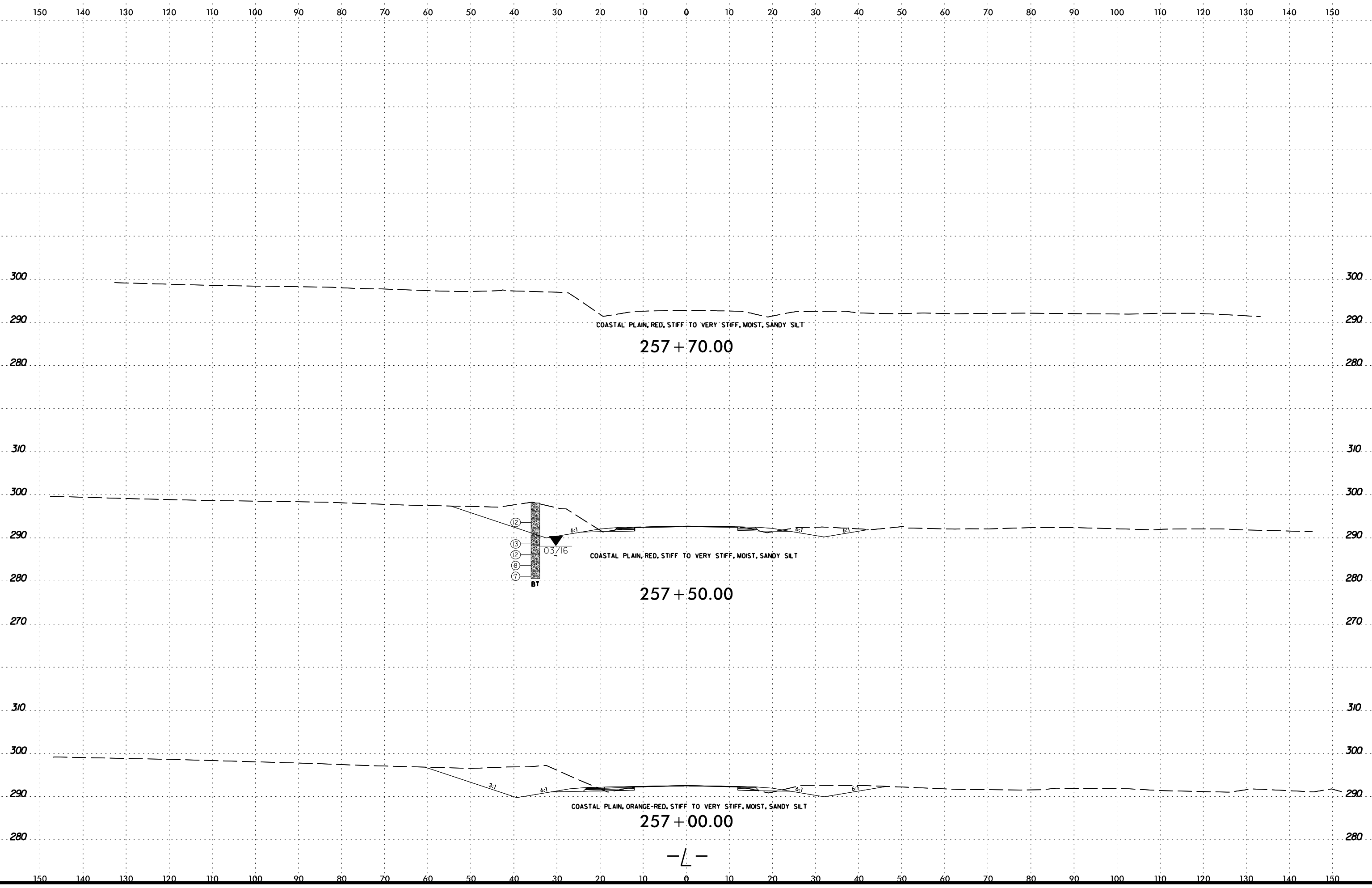

2/23/2017  
 M:\N\NCD01\R-3825B-R-3825B.GEO.RDWY..modifler\CA00.GEOTECH\sc\R3825B\_Geo\_xsi.1.166+50-257+70.dgn  
 C:\ur\imgton

6/23/16

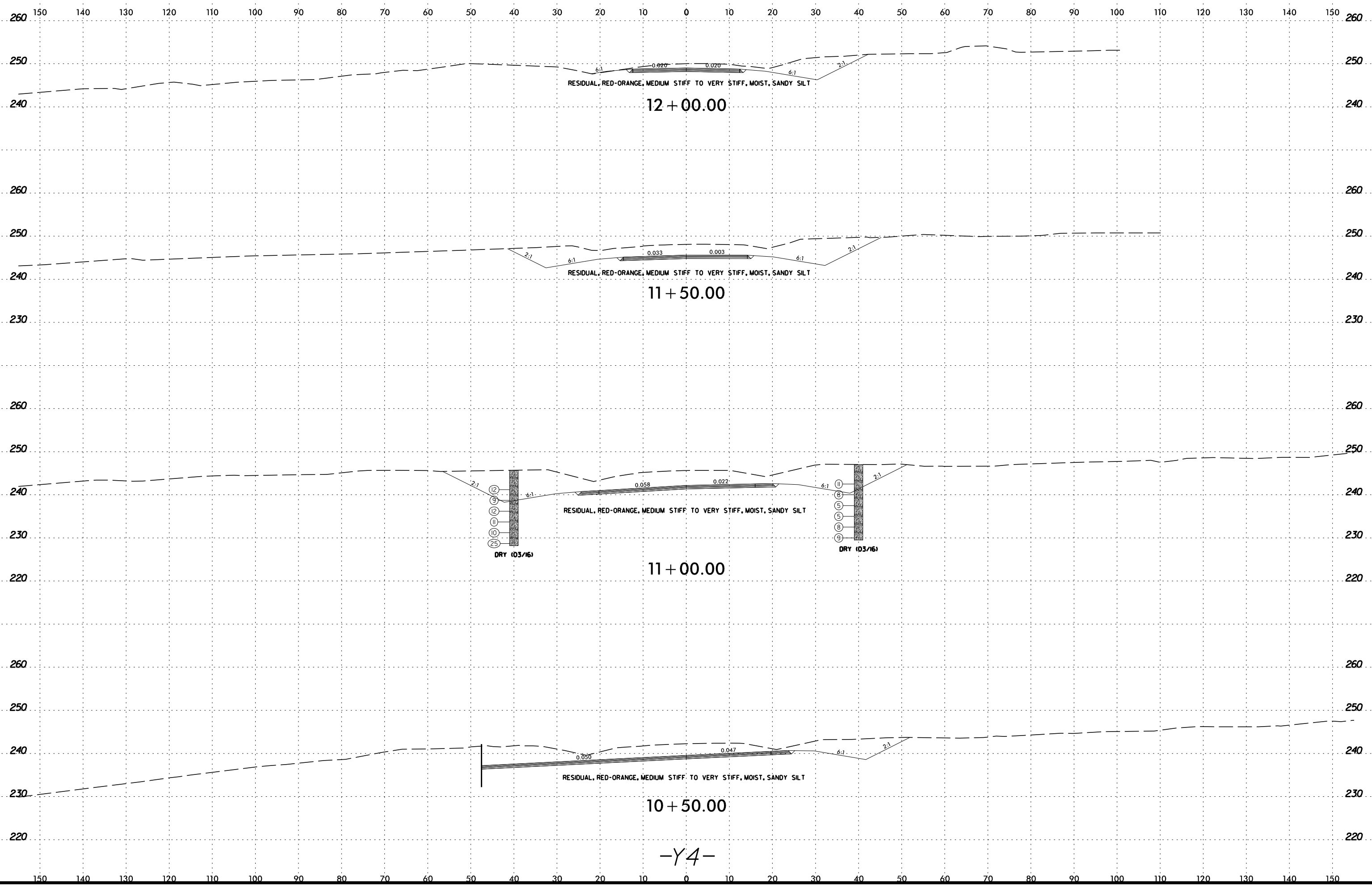

12 + 00.00

11 + 50.00

11 + 00.00

10 + 50.00

-Y4-

2/23/2017  
M:\N\NCD01\R-3825B\R-3825B\_GEO\_RDWY.mxd\ref\CA00\_GEO\TECH\sc\R3825B\_Geo\_xst\_1.f4.dgn  
C:\ur\imgton

6/23/16

150 140 130 120 110 100 90 80 70 60 50 40 30 20 10 0 10 20 30 40 50 60 70 80 90 100 110 120 130 140 150

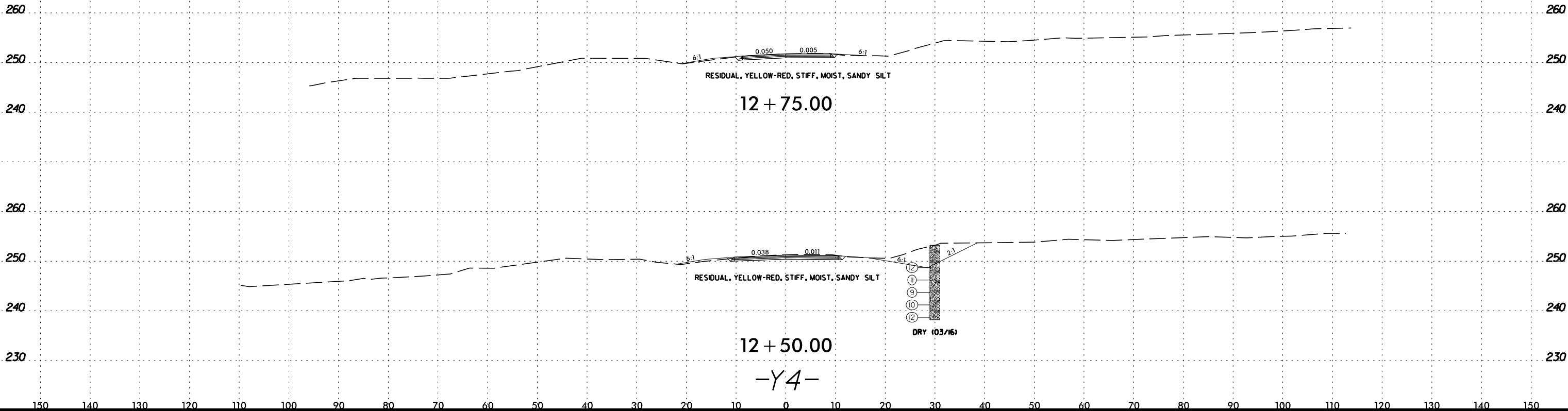

2/23/2017  
 M:\N\NCD01\R-3825B\R-3825B.GEO.RDWY...modif\er\CA00D.GEOTECH\sc\R3825B\_Geo\_xst\_14.dgn  
 C:\ur\imgton



6/23/16

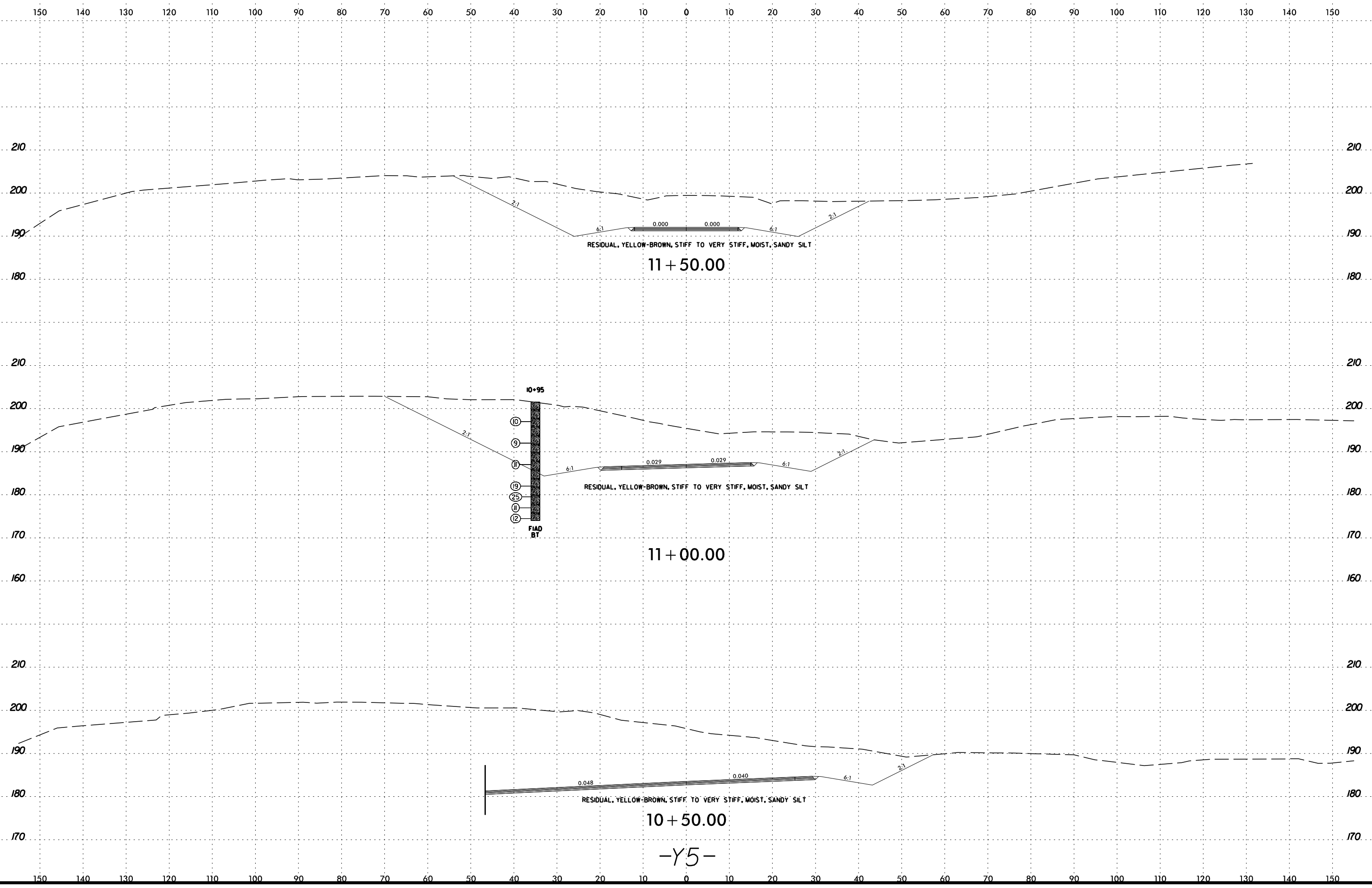

2/23/2017  
 M:\N\CD01\R-3825B\R-3825B.GEO.RDWY\_modif\er\CA00.GEOTECH\sc\R3825B\_Geo\_xst\_15.dgn  
 C:\ur\imgton

6/23/16

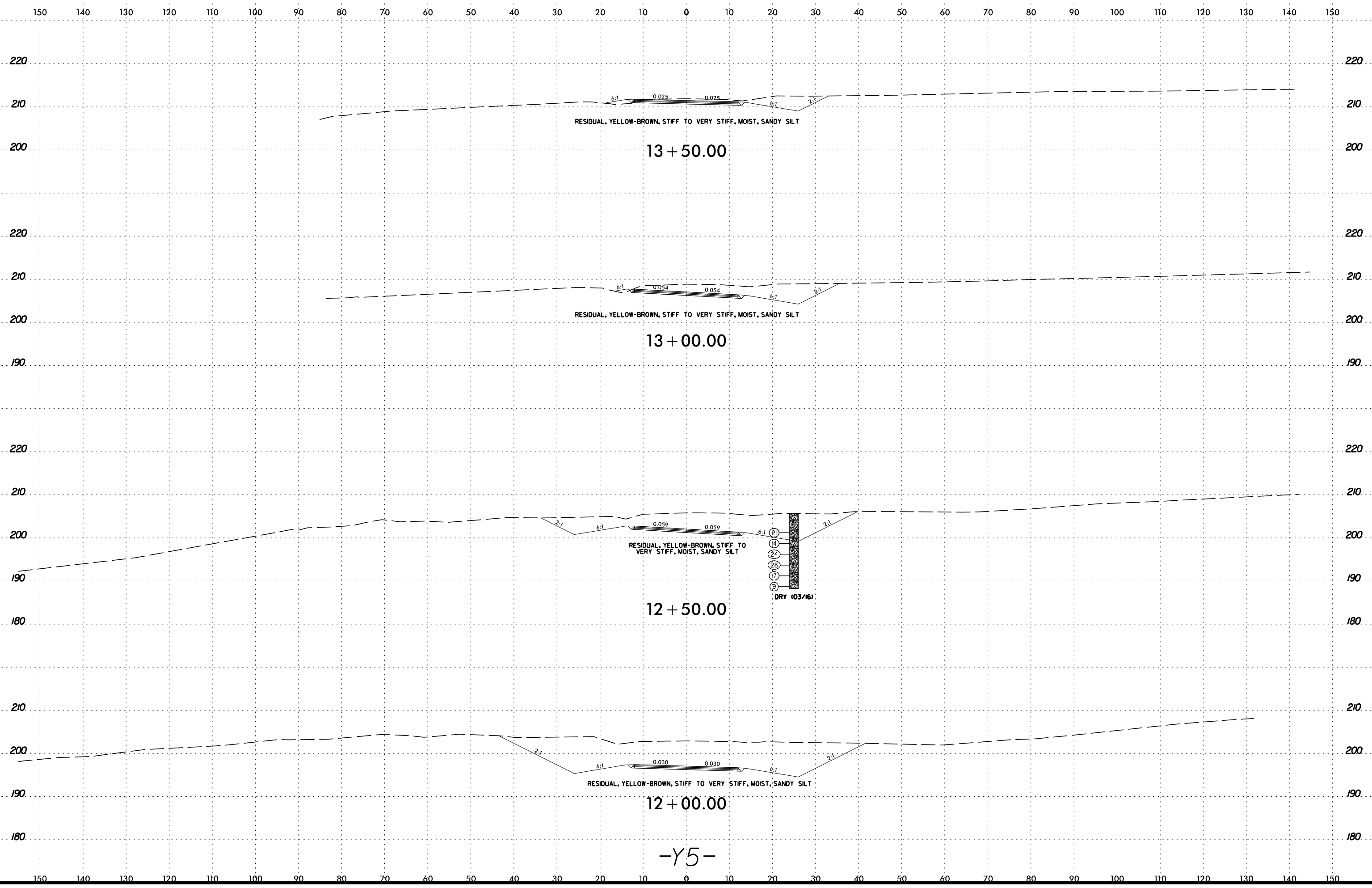

2/23/2017  
M:\N\NCD01\R-3825B\R-3825B.GEO\_RDWY..modif\er\CA00D\_GEO\TECH\sc\R3825B\_Geo\_xst\_15.dgn  
C:\ur\imgton

6/23/16

150 140 130 120 110 100 90 80 70 60 50 40 30 20 10 0 10 20 30 40 50 60 70 80 90 100 110 120 130 140 150

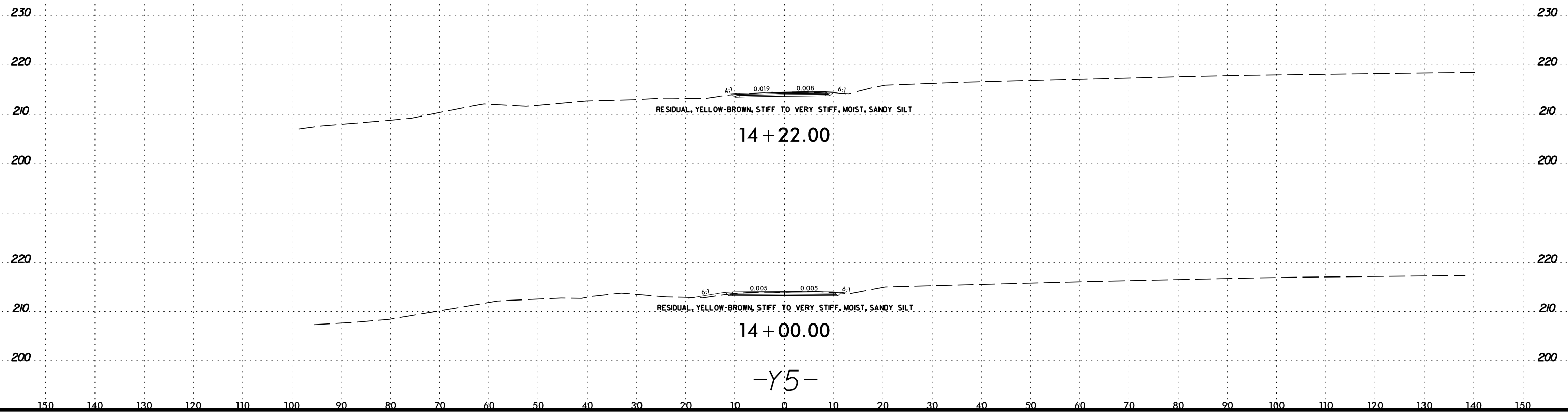

2/23/2017  
 M:\N\N\001\R-3825B-R-3825B.GEO.RDWY...modif...er\CA00.GEOTECH\ssc\R3825B\_Geo\_xst\_15.dgn  
 C:\ur\imgton

6/23/16

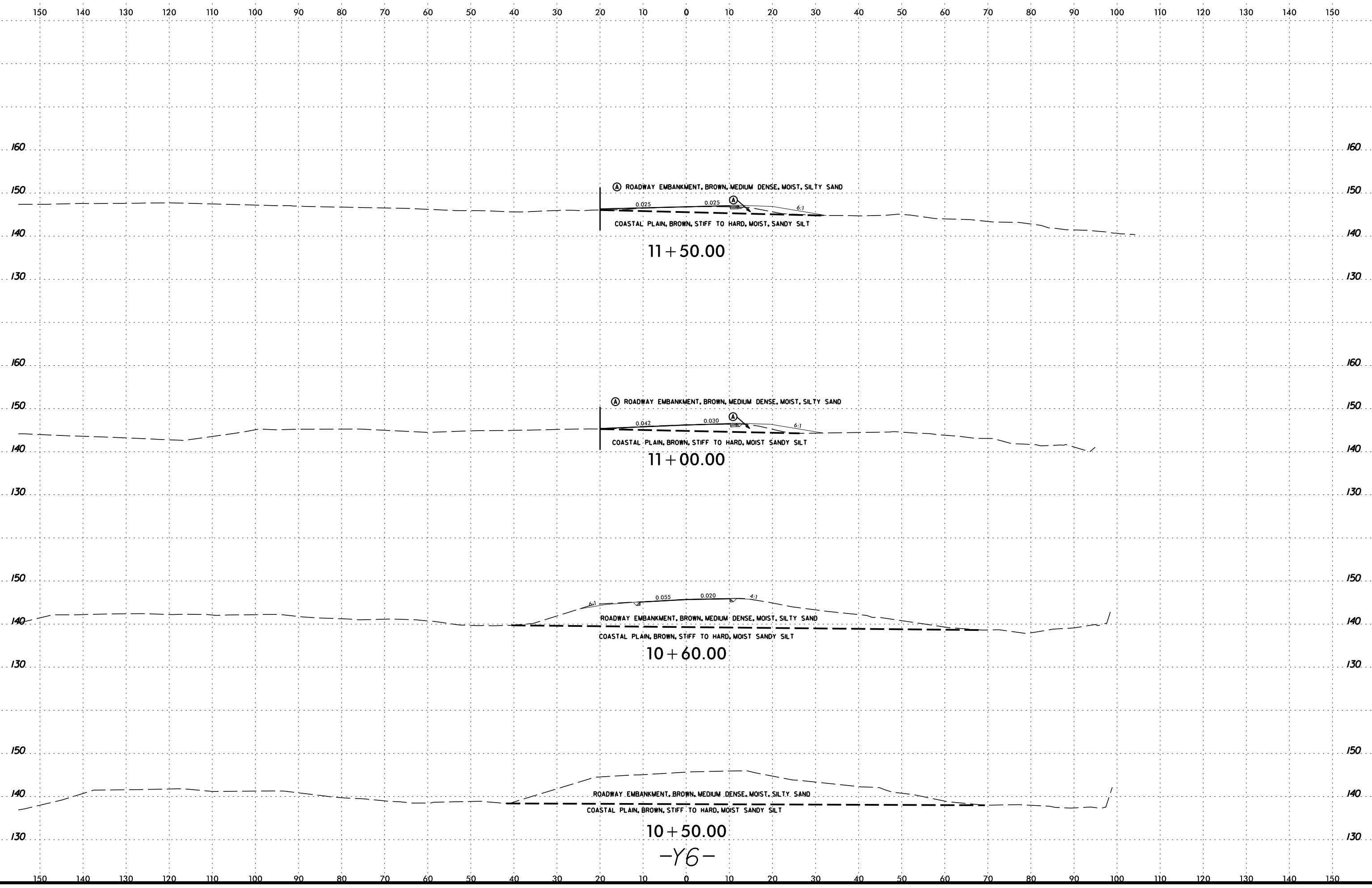

2/23/2017  
C:\Users\mcc01\OneDrive\Documents\R-3825B-R-3825B-GEO-RDWAY-modifier-CA00-GEOTECH\ssc\R3825B\_Geo\_xst\_16.dgn

10+50.00  
-Y6-

6/23/16  
2/23/2017  
M:\N\NCD01\R-3825B\GEO\_RDWY.mxd\fig\CA00\_GEO1TECH\sc\R3825B\_Geo\_xsi\_fig.dgn

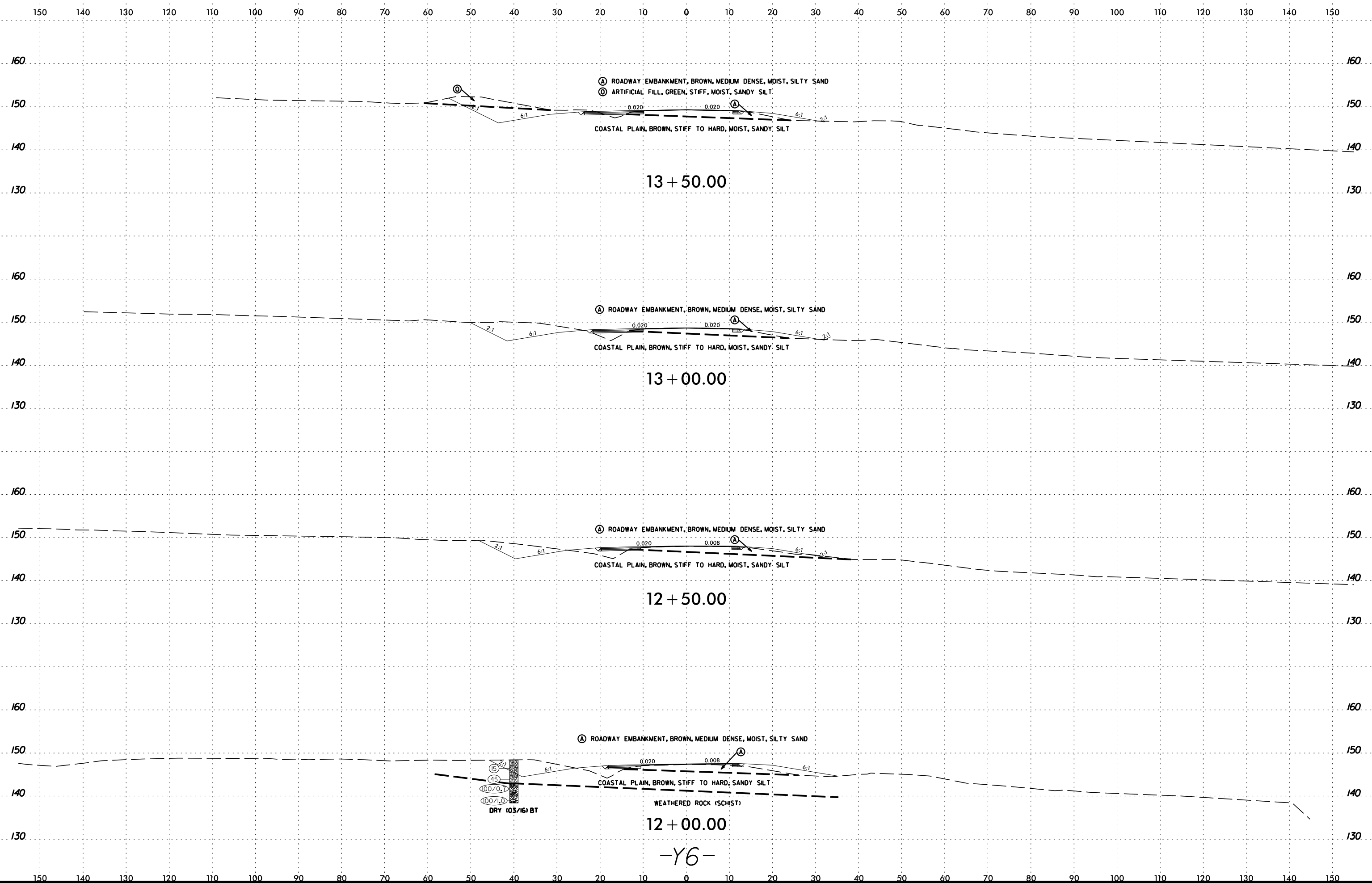

(A) ROADWAY EMBANKMENT, BROWN, MEDIUM DENSE, MOIST, SILTY SAND  
(B) ARTIFICIAL FILL, GREEN, STIFF, MOIST, SANDY SILT

13 + 50.00

(A) ROADWAY EMBANKMENT, BROWN, MEDIUM DENSE, MOIST, SILTY SAND  
(B) ARTIFICIAL FILL, GREEN, STIFF, MOIST, SANDY SILT

13 + 00.00

(A) ROADWAY EMBANKMENT, BROWN, MEDIUM DENSE, MOIST, SILTY SAND  
(B) ARTIFICIAL FILL, GREEN, STIFF, MOIST, SANDY SILT

12 + 50.00

(A) ROADWAY EMBANKMENT, BROWN, MEDIUM DENSE, MOIST, SILTY SAND  
(B) ARTIFICIAL FILL, GREEN, STIFF, MOIST, SANDY SILT

COASTAL PLAIN, BROWN, STIFF TO HARD, SANDY SILT

WEATHERED ROCK (SCHIST)

12 + 00.00

DRY (03/16) BT

-Y6-

6/23/16

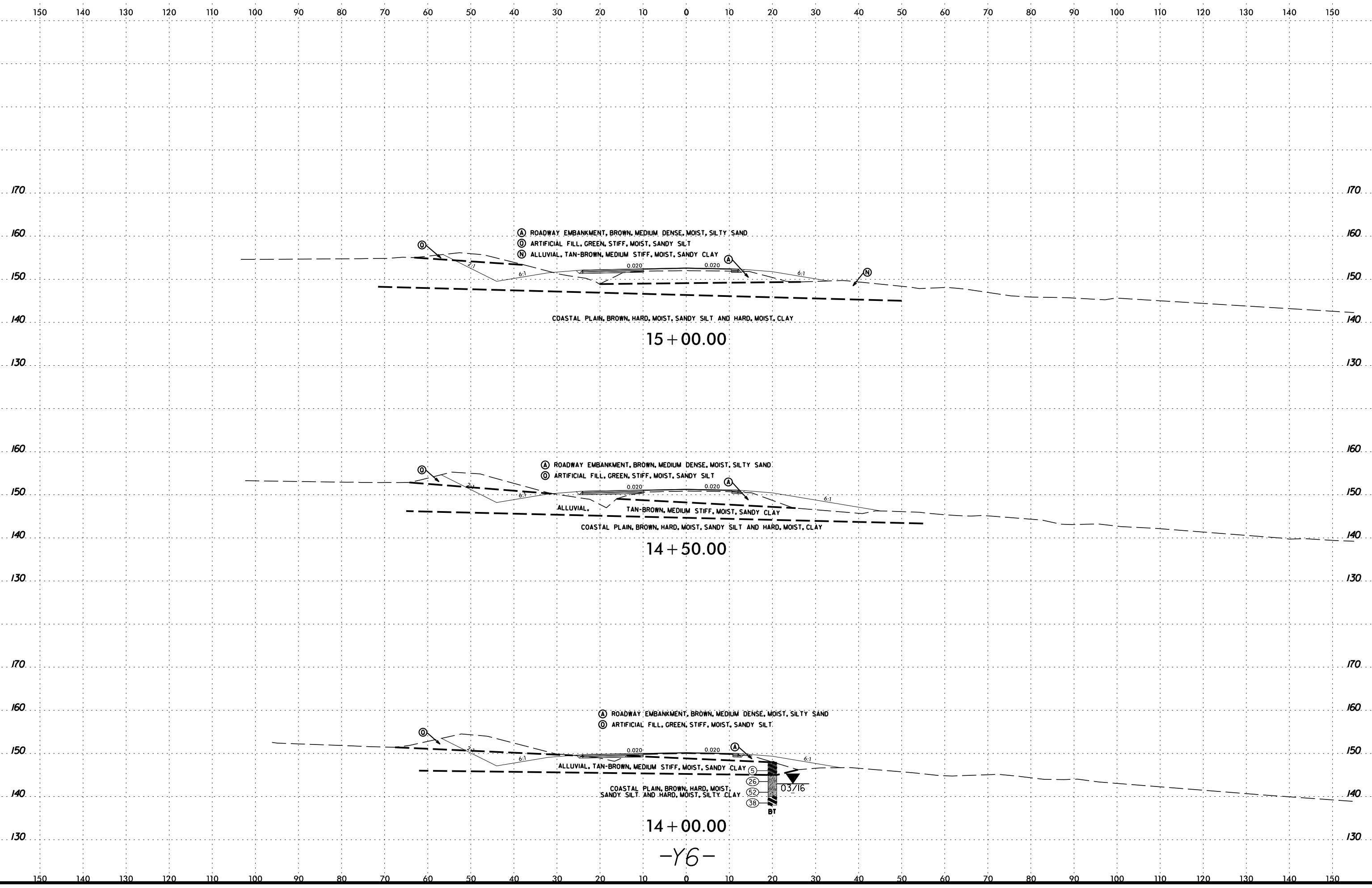

2/23/2017  
M:\N\NCD001\R-3825B\R-3825B.GEO\_RDWY.mxd  
C:\Users\jg6\dgn

6/23/16

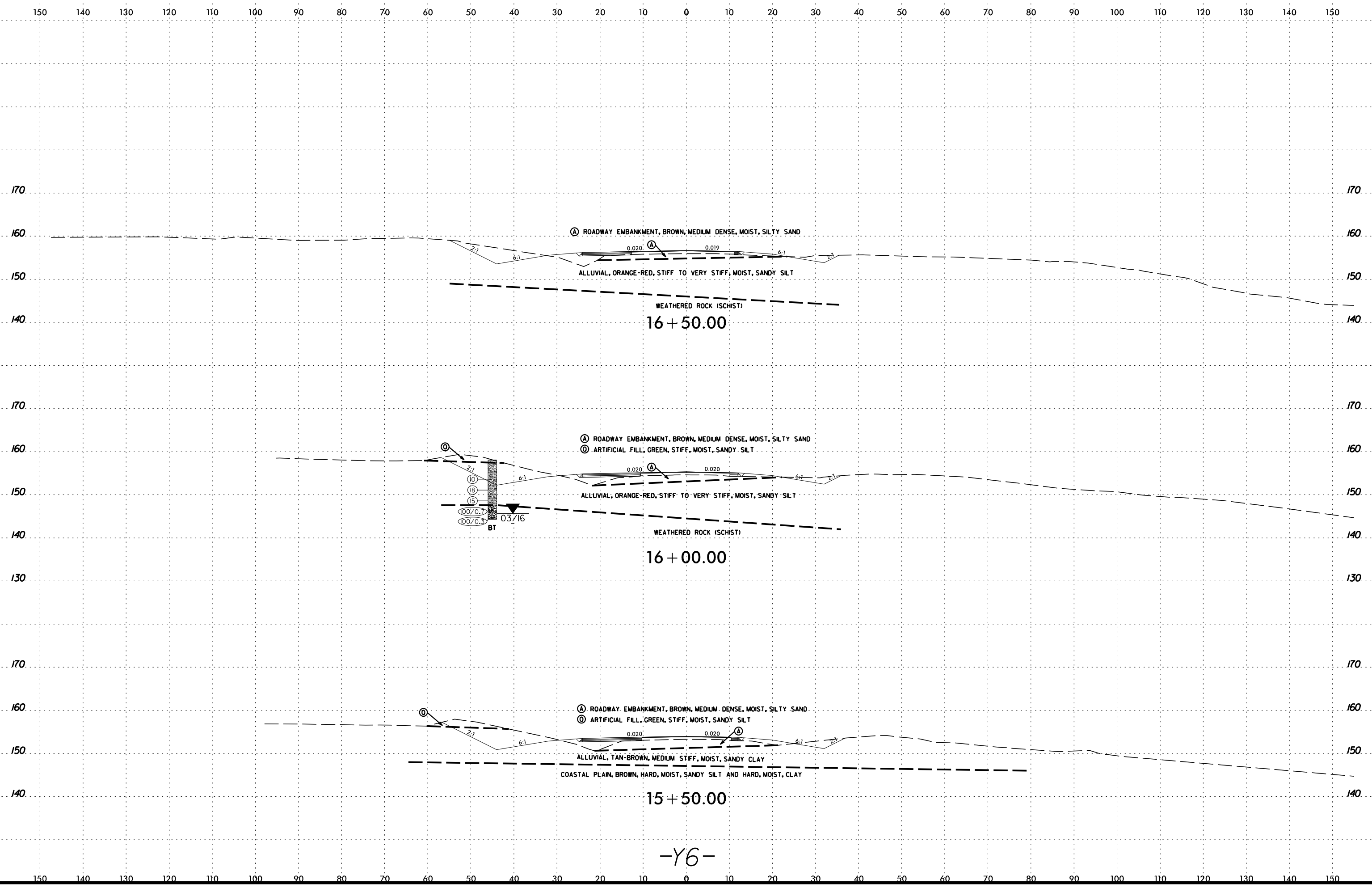

2/23/2017 11:51:00 AM C:\Users\mcc01\OneDrive\Documents\2017\Projects\3825B\RDWY\modif\ter\CA00D\_GEO1\TECH\3825B\_GEO.XSI\3825B\_GEO.XSI.dgn

-Y6-

6/23/16

150 140 130 120 110 100 90 80 70 60 50 40 30 20 10 0 10 20 30 40 50 60 70 80 90 100 110 120 130 140 150

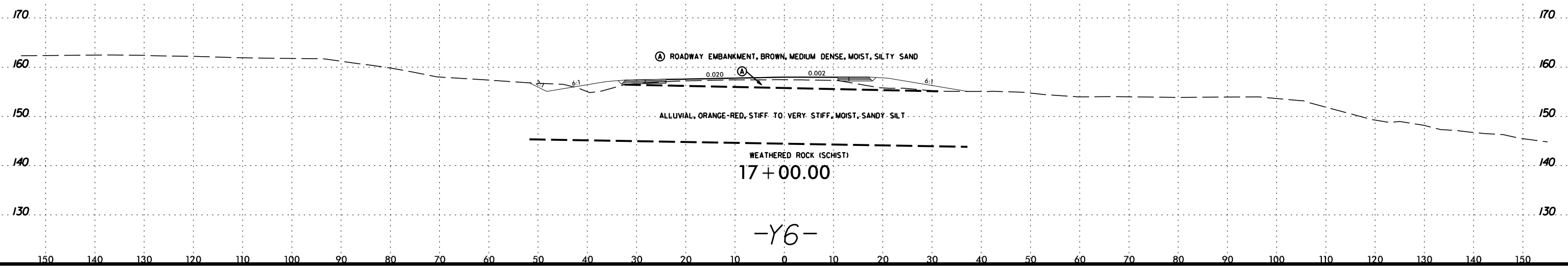

2/23/2017  
 M:\N\NCD01\R-3825B\R-3825B.GEO\_RDWY\_modif\er\CA00.GEOTECH\sc\R3825B\_Geo\_xst\_16.dgn  
 C:\ur\lmgton



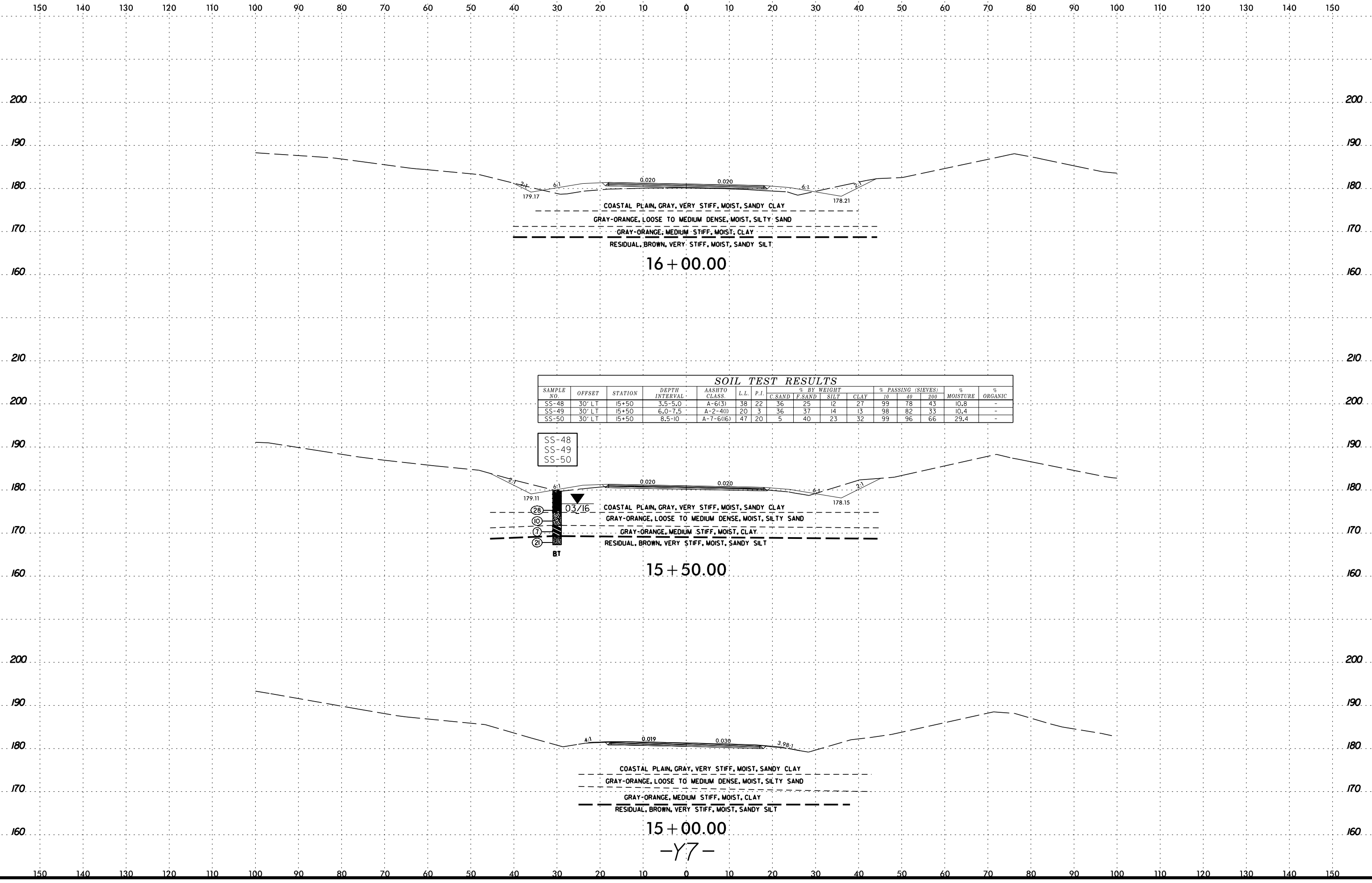

**SOIL TEST RESULTS**

SAMPLE NO.	OFFSET	STATION	DEPTH INTERVAL	AASHTO CLASS	L.L.	P.I.	% BY WEIGHT				% PASSING (SIEVES)			% MOISTURE	% ORGANIC
							C. SAND	F. SAND	SILT	CLAY	10	40	200		
SS-48	30' LT	15+50	3.5-5.0	A-6(3)	38	22	36	25	12	27	99	78	43	10.8	-
SS-49	30' LT	15+50	6.0-7.5	A-2-4(0)	20	3	36	37	14	13	98	82	33	10.4	-
SS-50	30' LT	15+50	8.5-10	A-7-6(16)	47	20	5	40	23	32	99	96	66	29.4	-

SS-48  
SS-49  
SS-50

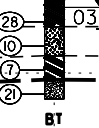

6/23/16

150 140 130 120 110 100 90 80 70 60 50 40 30 20 10 0 10 20 30 40 50 60 70 80 90 100 110 120 130 140 150

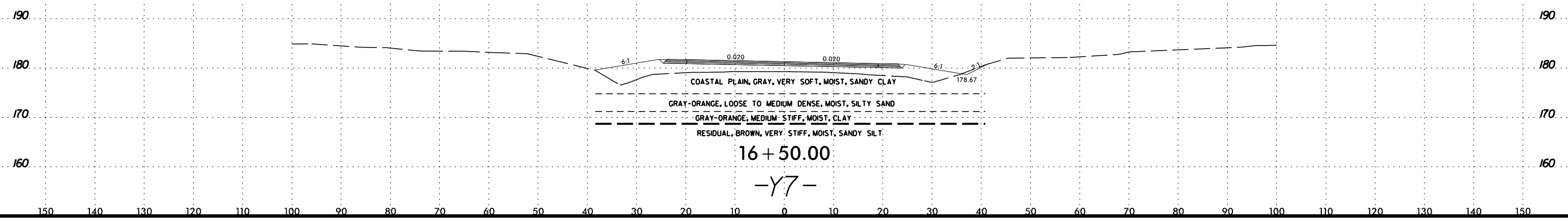

2/23/2017  
 M:\N\NCD01\R-3825B\R-3825B.GEO.RDWY..modif\er\CA0D.GEOTECH\sc\R3825B\_Geo\_xst.y7.dgn  
 C:\ur\imgton

6/23/16

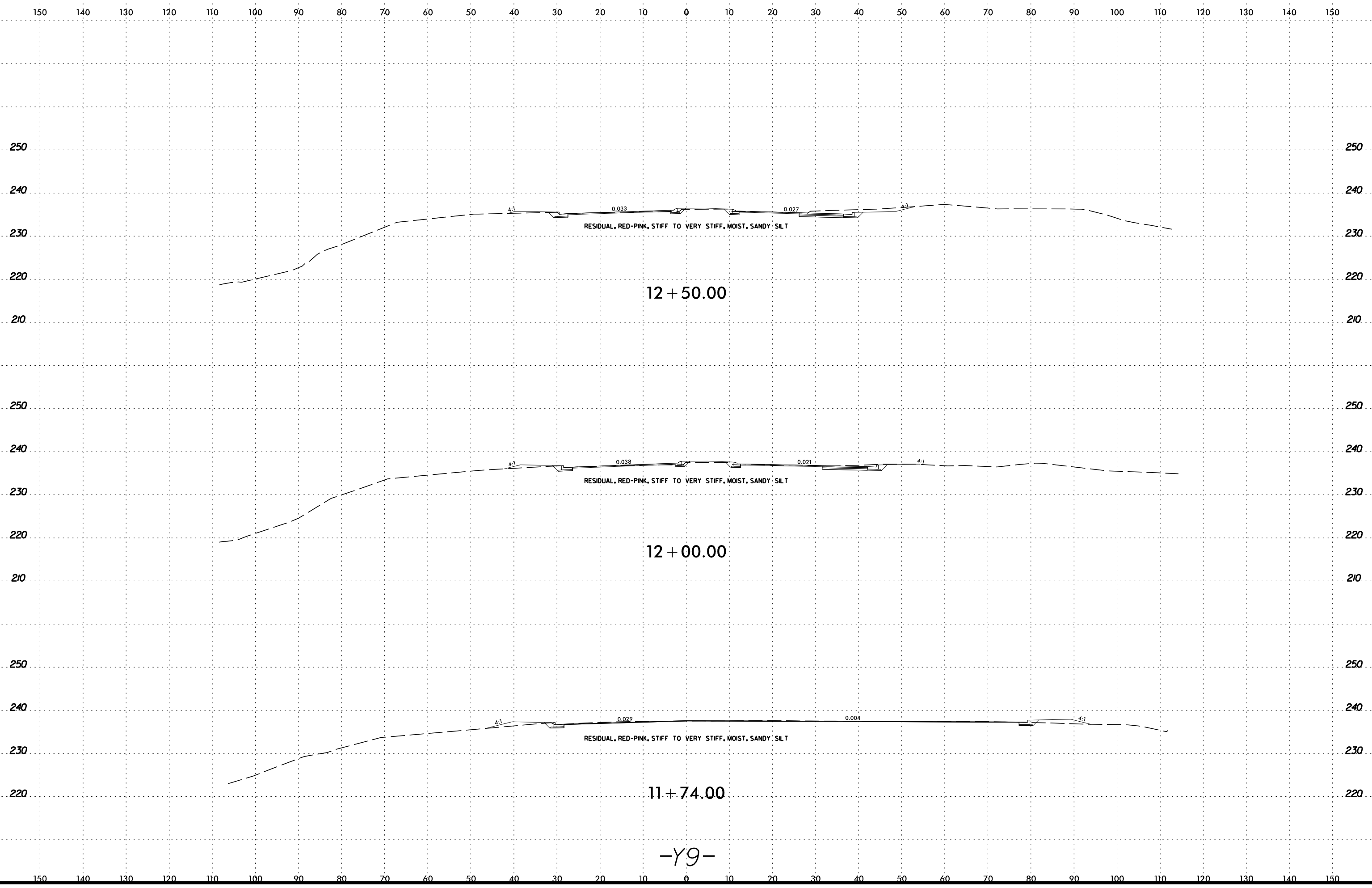

2/23/2017  
M:\N\NCD01\R-3825B\R-3825B\_GEO\_RDWY.mxd  
C:\Program Files\Autodesk\AutoCAD 2010\AutoCAD.exe

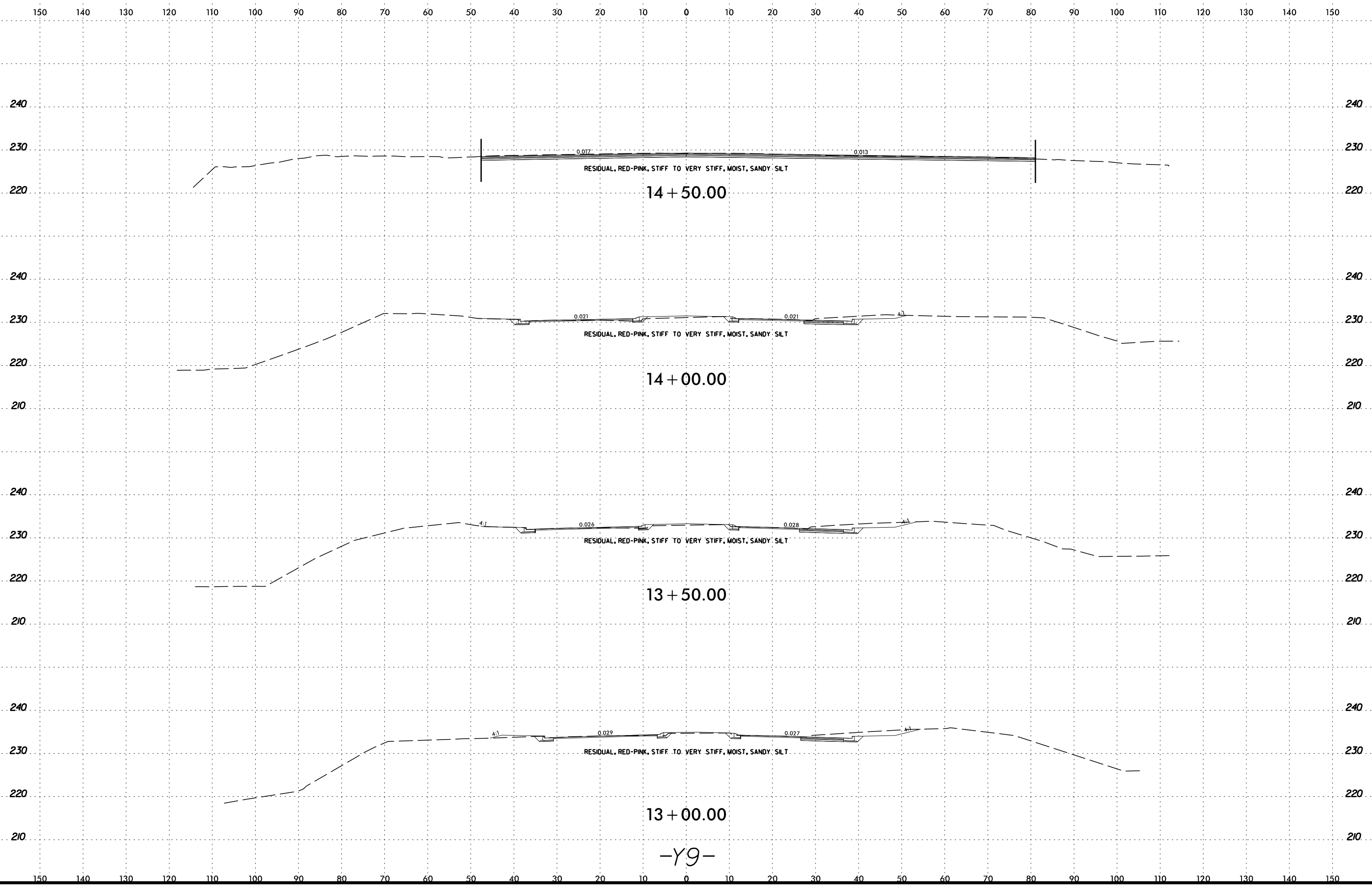

6/23/16

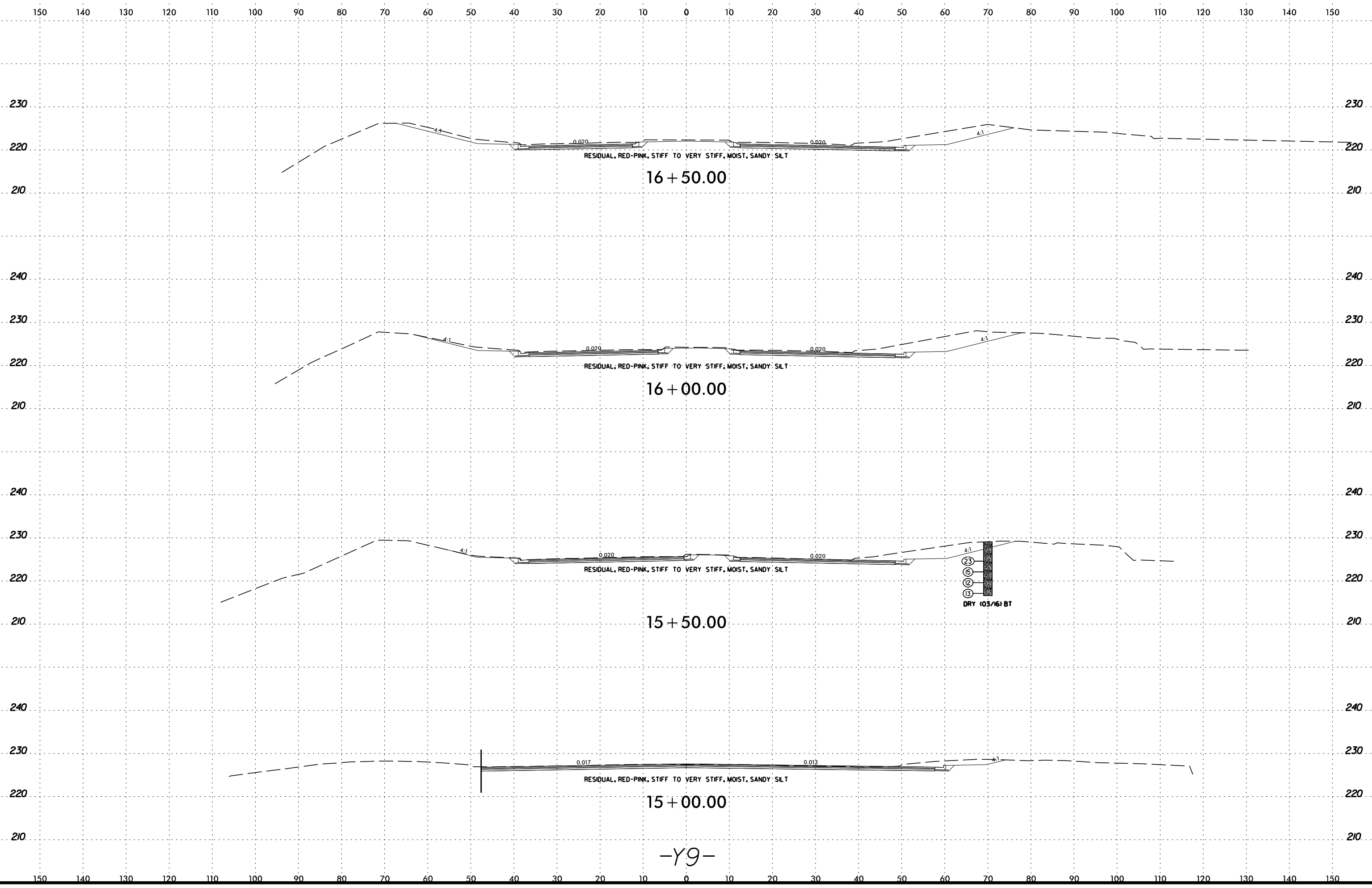

16 + 50.00

16 + 00.00

15 + 50.00

15 + 00.00

-Y9-

4:1  
 23  
 15  
 12  
 13  
 DRY 103/161 BT

2/23/2017  
 M:\N\NCD01\R-3825B\R-3825B.GEO\_RDWY.mxd  
 C:\Program Files\Autodesk\AutoCAD 2010\AutoCAD.exe

6/23/16

150 140 130 120 110 100 90 80 70 60 50 40 30 20 10 0 10 20 30 40 50 60 70 80 90 100 110 120 130 140 150

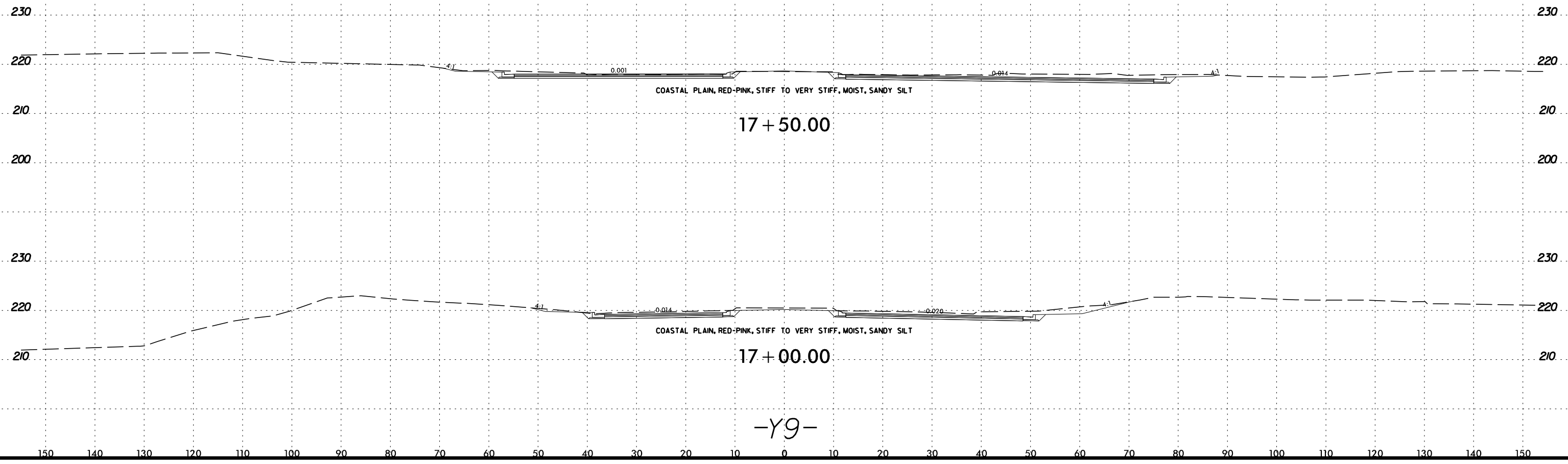

2/23/2017  
 M:\N\NCD01\R-3825B\R-3825B.GEO\_RDWY\_modif\er\CA0D\_GEO\TECH\sc\R3825B\_Geo\_xst\_9.dgn  
 C:\ur\lmgton

-Y9-

6/23/16

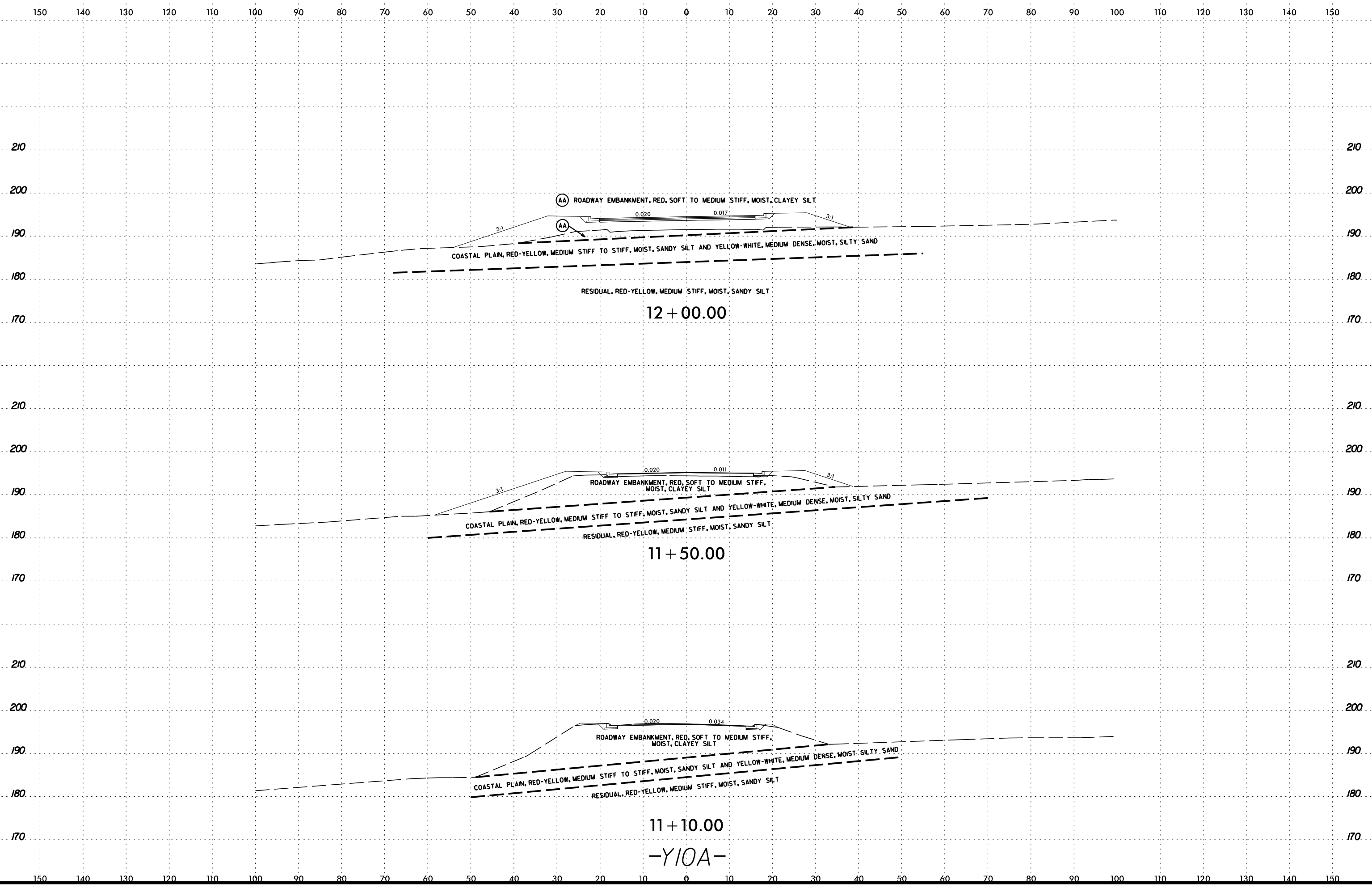

2/23/2017  
M:\N\CD01\R-3825B-R-3825B-Geo.-RDWY-modifier-CA00-GEOTECH\sc\VR3825B-Geo.xst-ylj0a.dgn

6/23/16

150 140 130 120 110 100 90 80 70 60 50 40 30 20 10 0 10 20 30 40 50 60 70 80 90 100 110 120 130 140 150

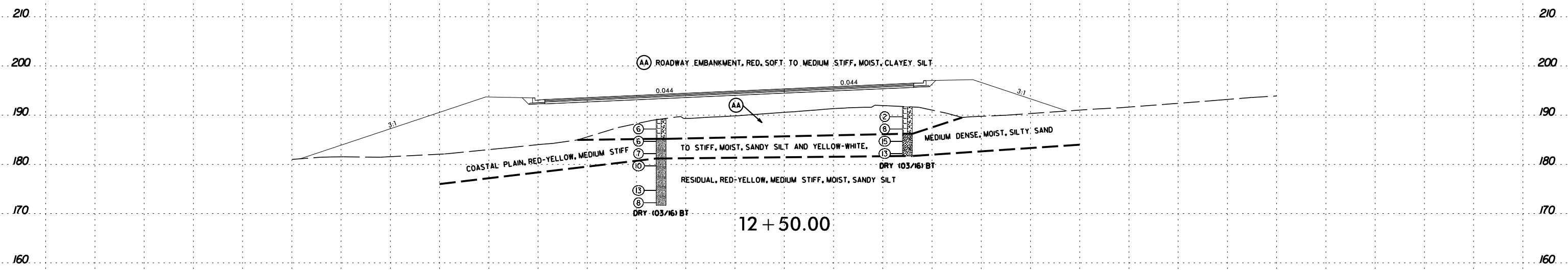

12 + 50.00

-Y10A-

2/23/2017  
M:\N\NCD01\R-3825B\R-3825B.GEO\_RDWY.mxd  
C:\Users\j10a.dgn



6/23/16

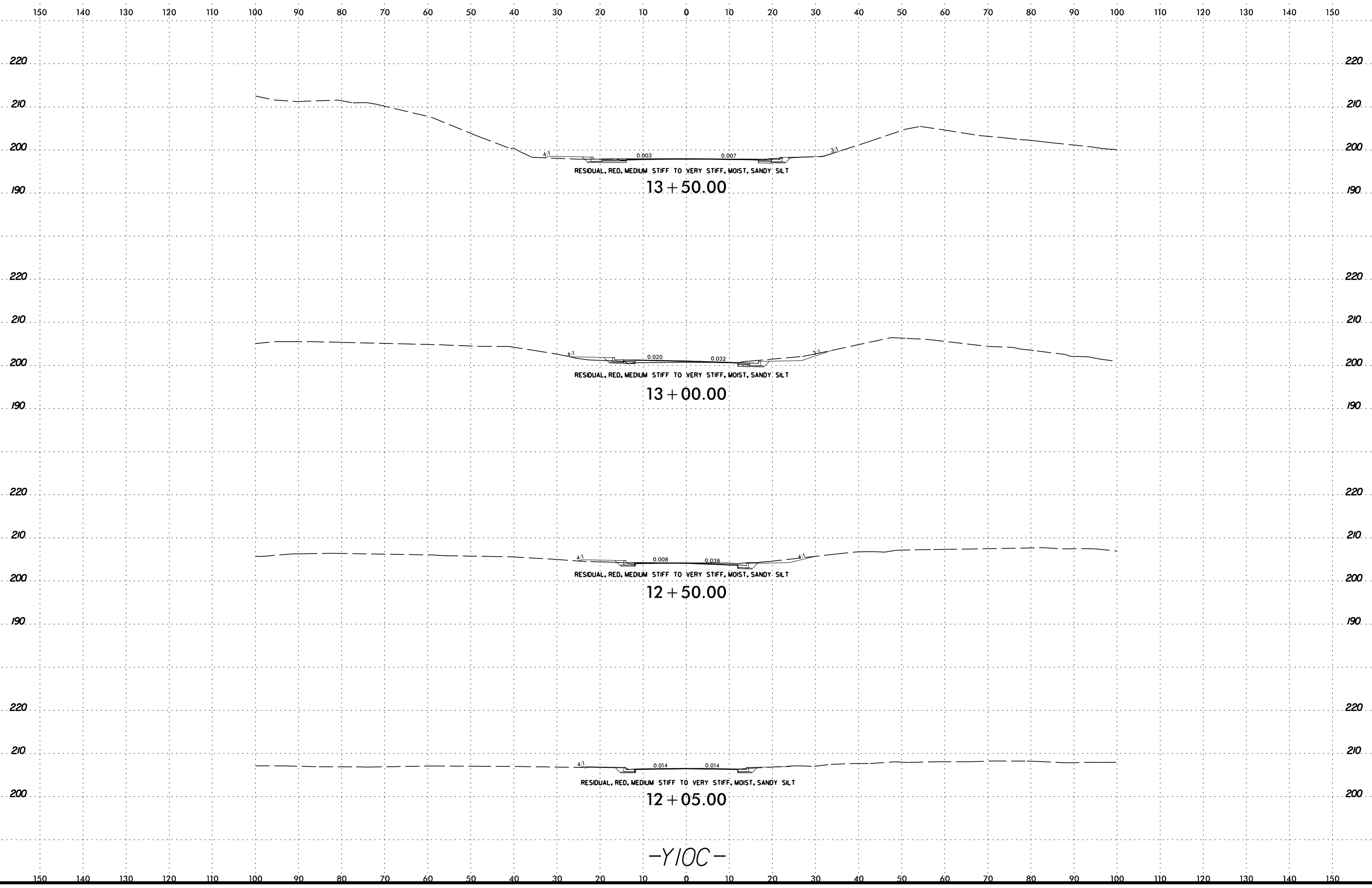

-YIOC-

2/23/2017  
M:\N\NCD01\R-3825B\R-3825B.GEO\_RDWY.mxd  
C:\Users\lmgton

6/23/16

150 140 130 120 110 100 90 80 70 60 50 40 30 20 10 0 10 20 30 40 50 60 70 80 90 100 110 120 130 140 150

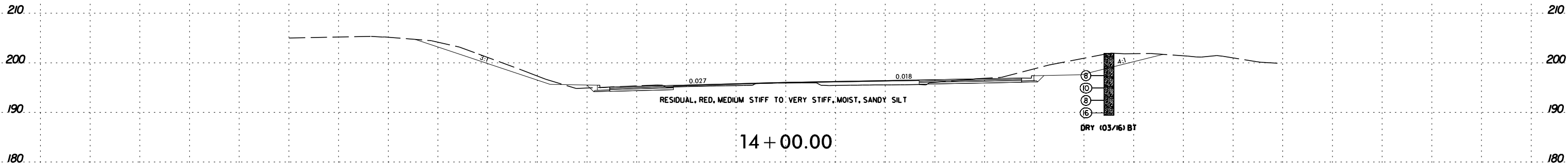

14 + 00.00

-Y10C-

2/23/2017  
M:\N\NCD01\R-3825B\R-3825B.GEO.RDWY...modif\er\CA0D.GEOTECH\sc\R3825B\_Geo\_xst.jl0c.dgn  
C:\ur\ington

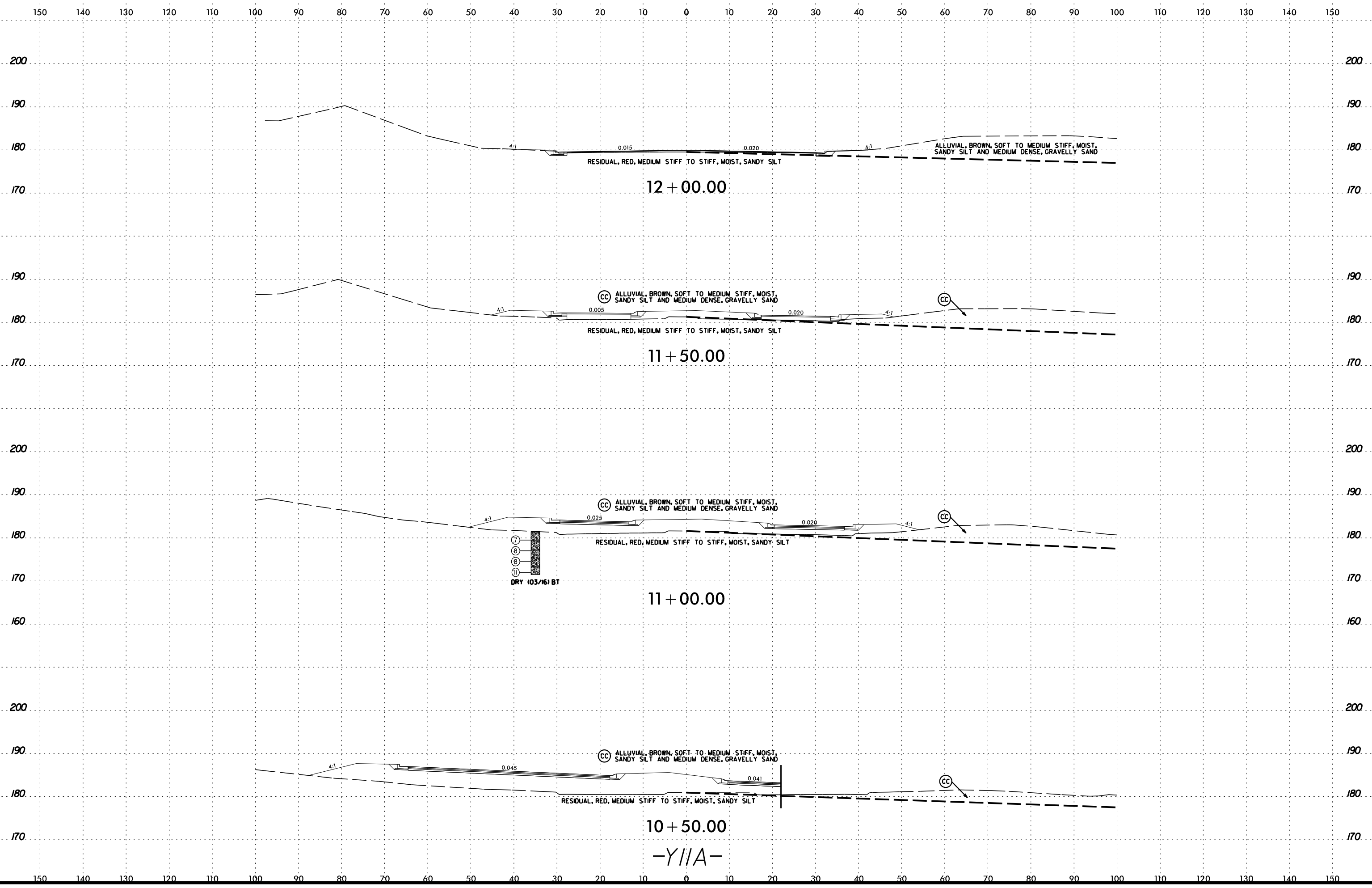

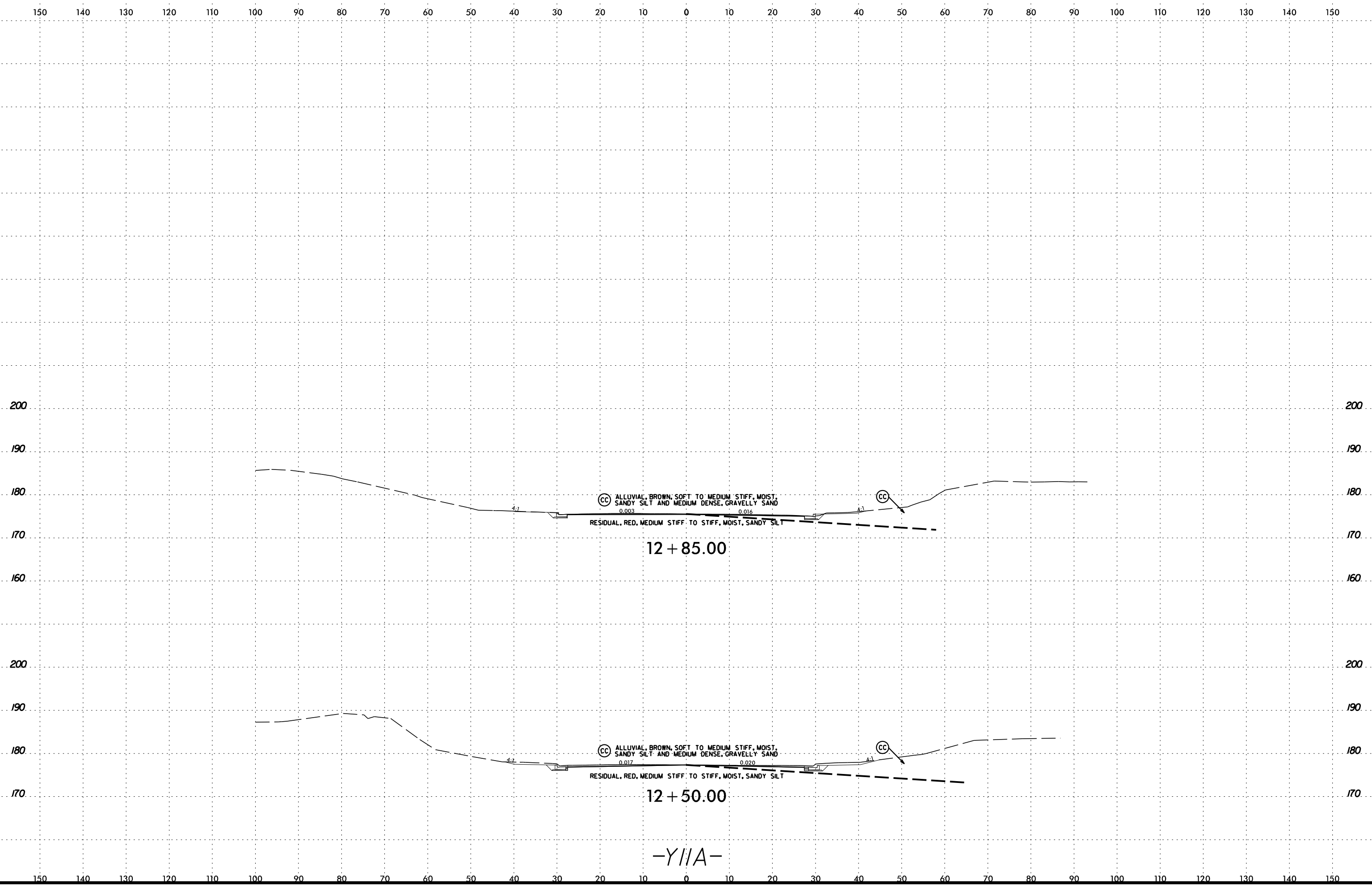

6/23/16

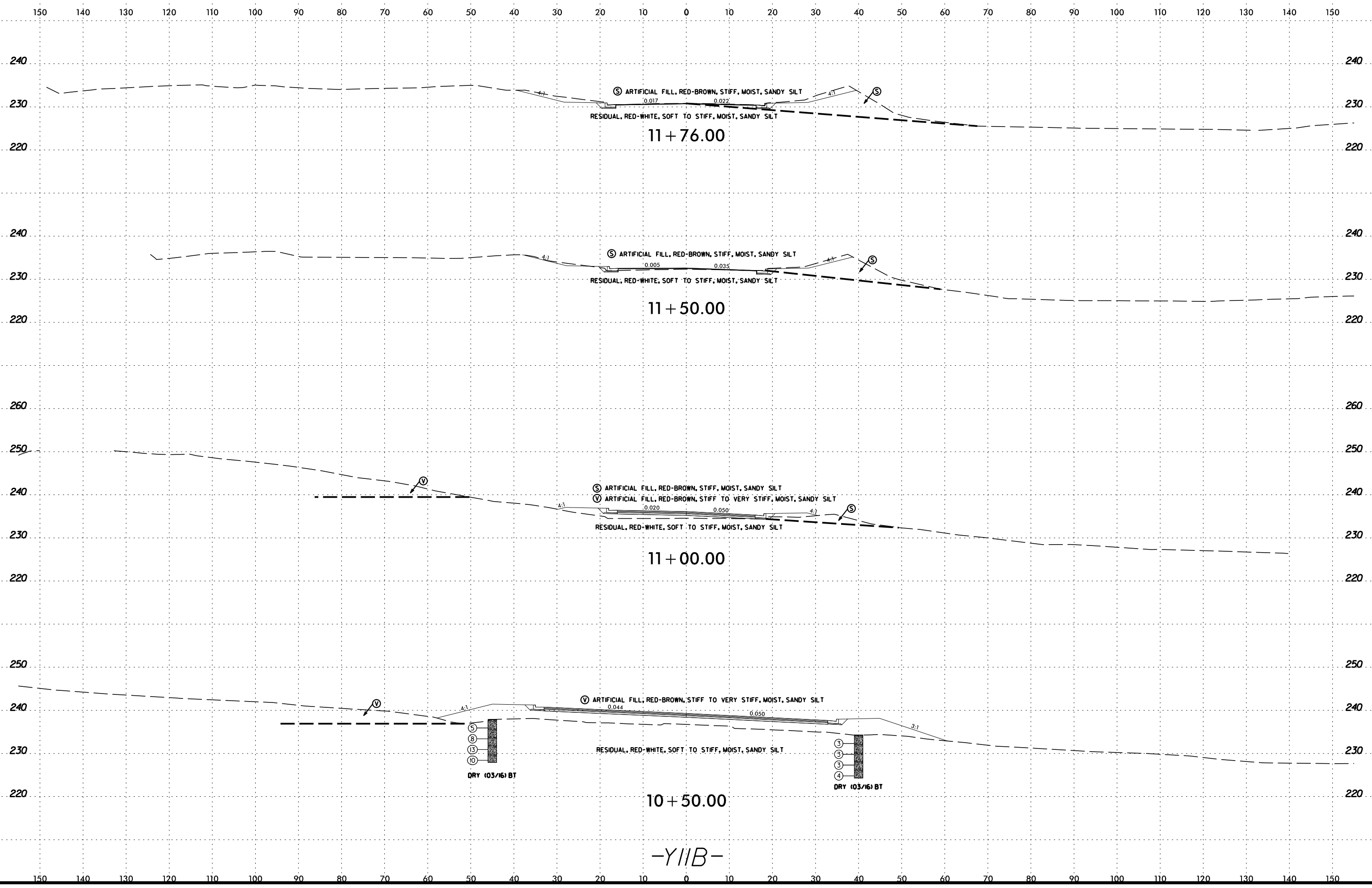

2/23/2017  
M:\N\CD01\R-3825B\R-3825B.GEO\_RDWY\_modif\er\CA00D\_GEO\TECH\sc\R3825B\_Geo\_xst\_gllb.dgn  
C:\Program Files\Autodesk\AutoCAD 2017\lib

-YIIB-

6/23/16

150 140 130 120 110 100 90 80 70 60 50 40 30 20 10 0 10 20 30 40 50 60 70 80 90 100 110 120 130 140 150

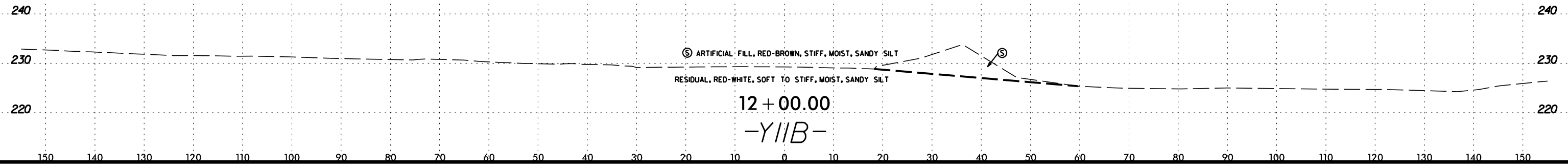

2/23/2017  
 M:\N\NCD01\R-3825B\R-3825B.GEO.RDWY...modif\er\CA0D.GEOTECH\sc\R3825B\_Geo\_xst.g11b.dgn  
 C:\ur\lmgton

6/23/16

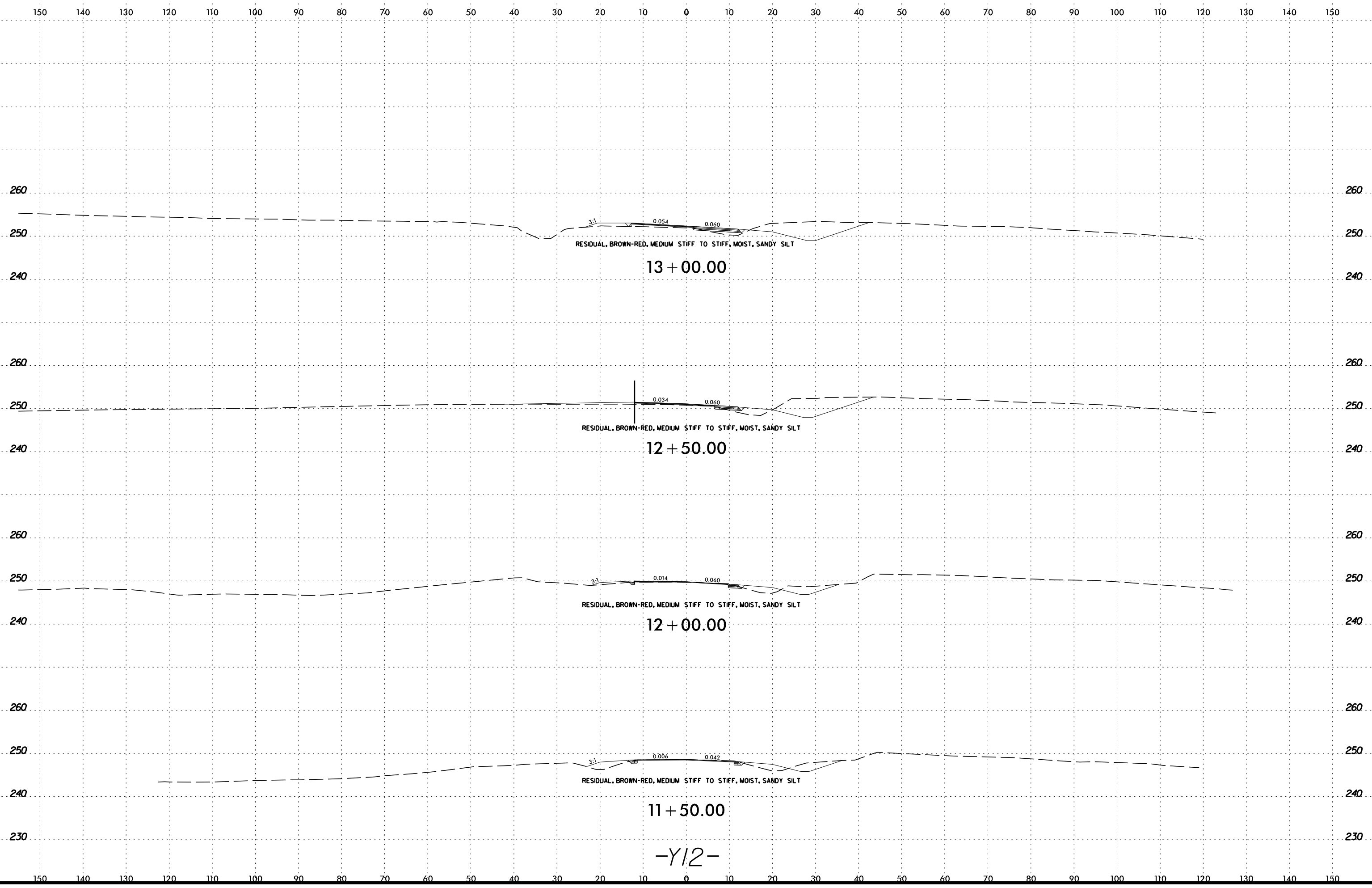

2/23/2017  
M:\N\NCD01\R-3825B\R-3825B.GEO\_RDWY\_modif\er\CA00\_GEO\TECH\sc\R3825B\_Geo\_xst\_yl2.dgn  
C:\ur\lmgton

-Y12-

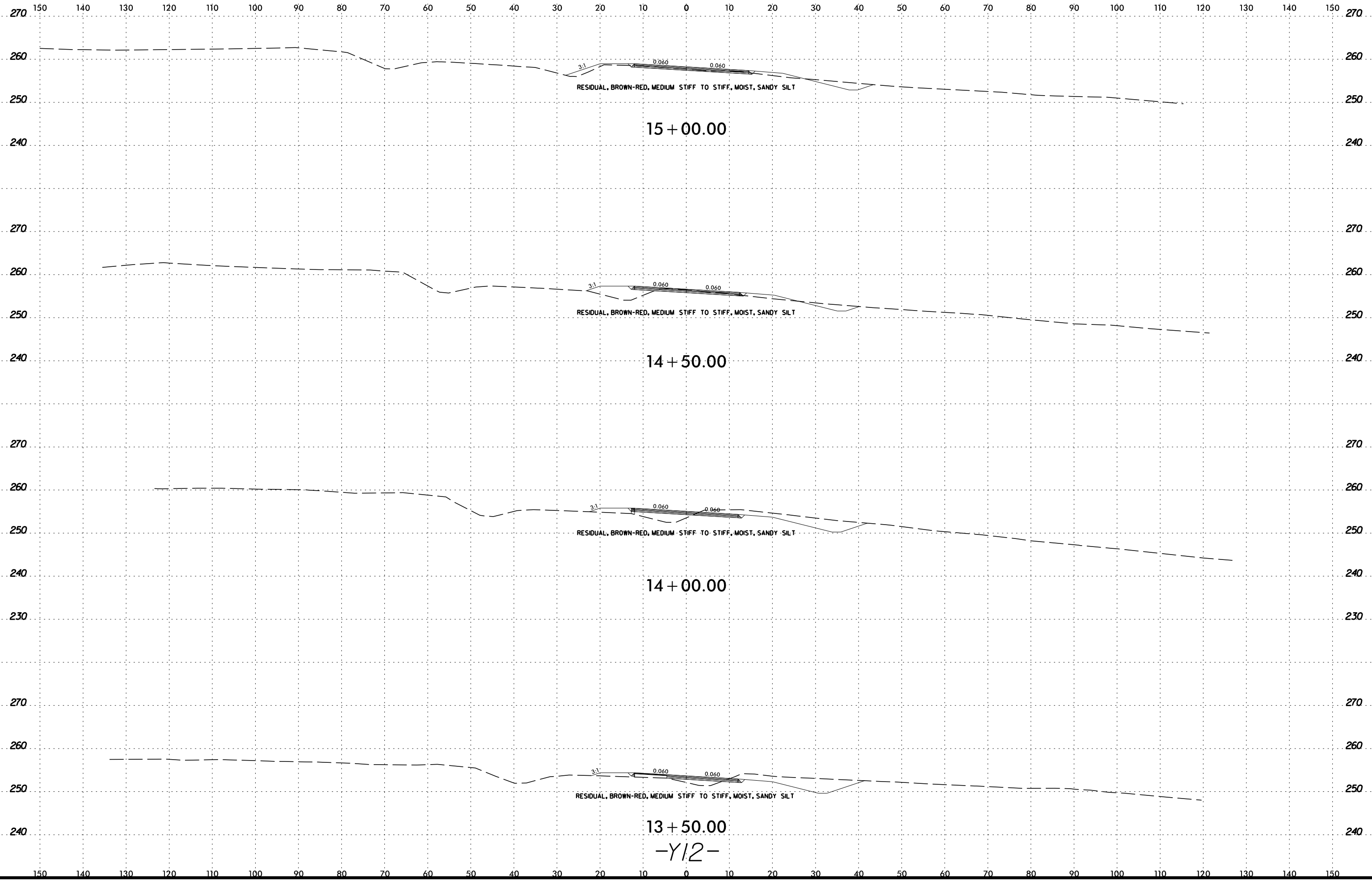

2/23/2017  
 M:\N\NCD01\R-3825B\R-3825B\_GEO\_RDWY.mxd  
 C:\Program Files\Autodesk\AutoCAD 2010\acad.ctb

13 + 50.00  
 -Y12-



6/23/16

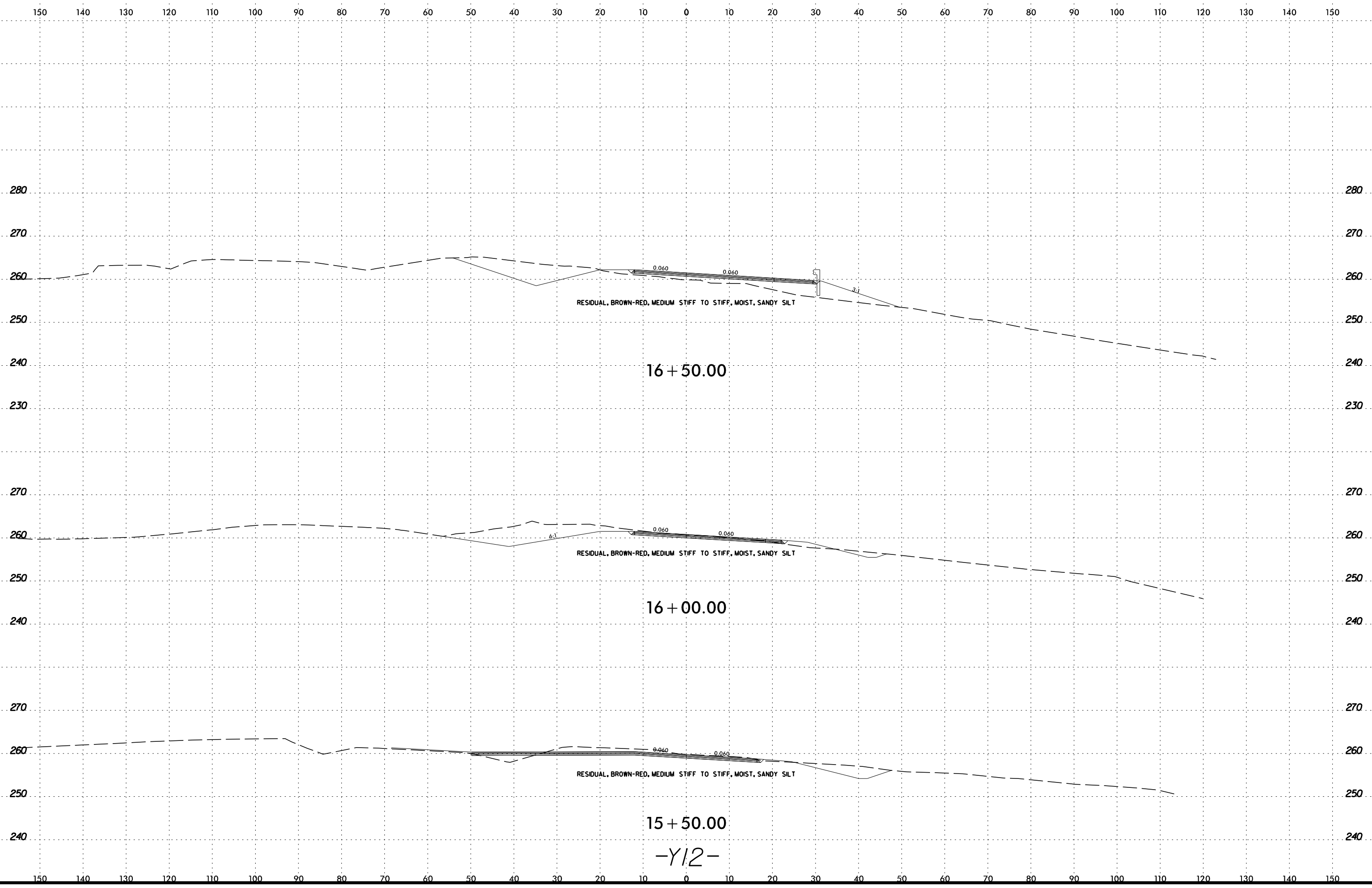

2/23/2017  
C:\Users\mcc01\OneDrive\Documents\2017\Projects\2017\20170223\20170223.dgn

16 + 50.00

16 + 00.00

15 + 50.00

-Y12-

6/23/16

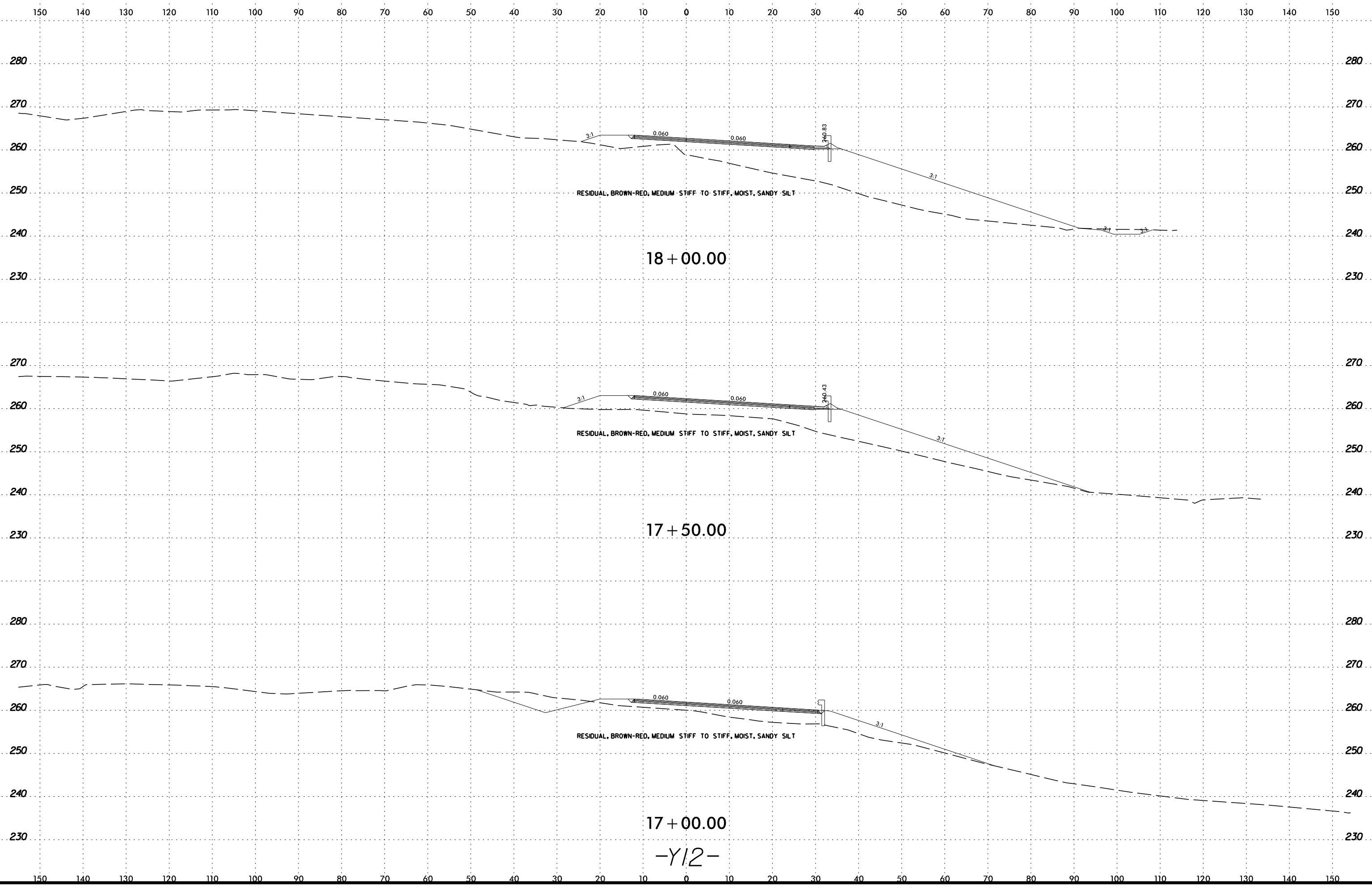

2/23/2017  
M:\N\NCD01\R-3825B\R-3825B.GEO\_RDWY\_modif\er\CA00\_GEO\TECH\sc\R3825B\_Geo\_xst\_yl2.dgn  
C:\ur\ington

17 + 00.00  
-Y12-

6/23/16

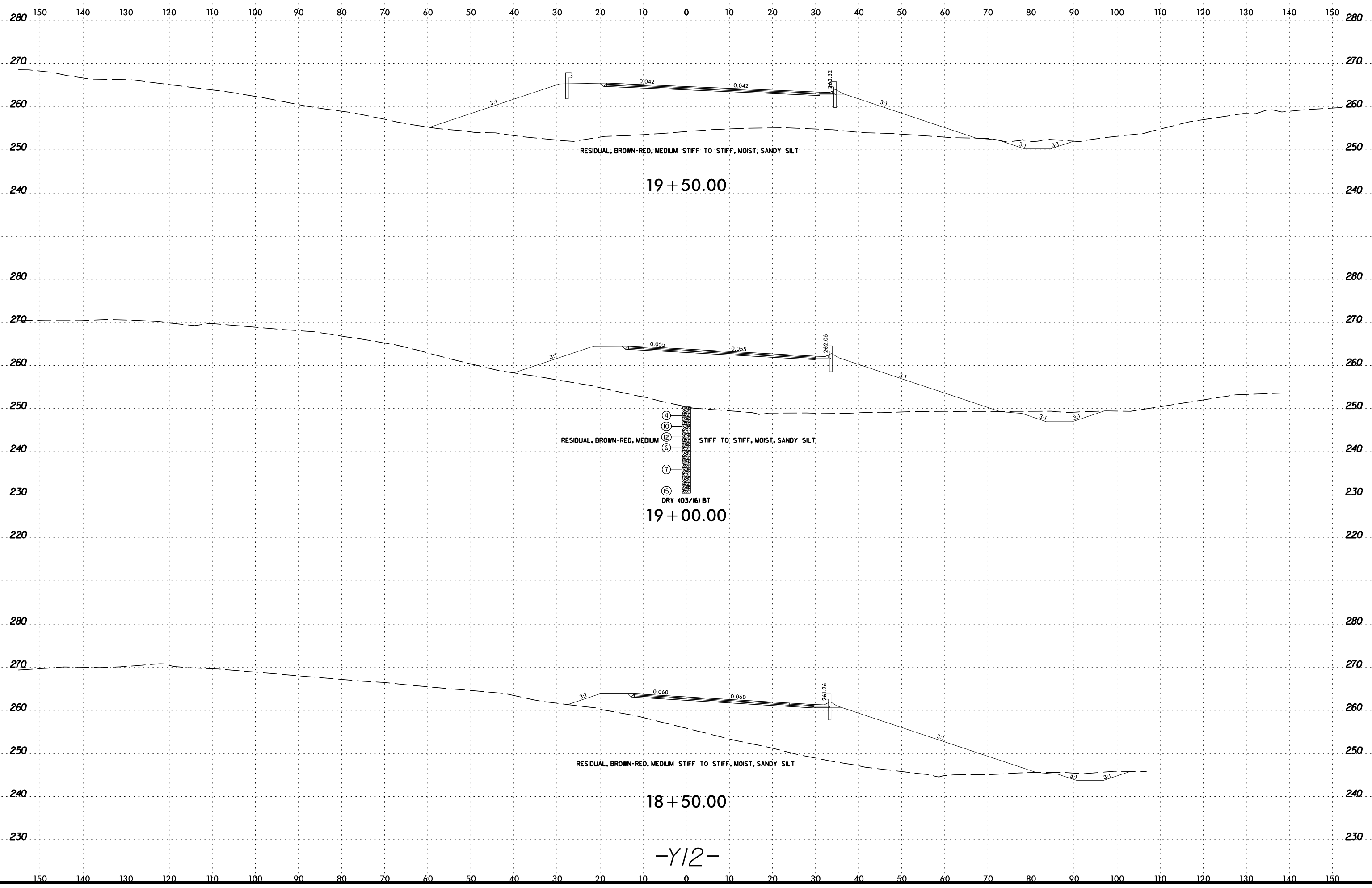

19 + 50.00

19 + 00.00

18 + 50.00

-Y12-

2/23/2017  
M:\N\NCD01\R-3825B\R-3825B\_GEO\_RDWY.mxd  
C:\Users\lmgton

6/23/16  
2/23/2017  
C:\Users\mcc01\OneDrive\Documents\Projects\2017\20170223\20170223\_01\20170223\_01.dgn

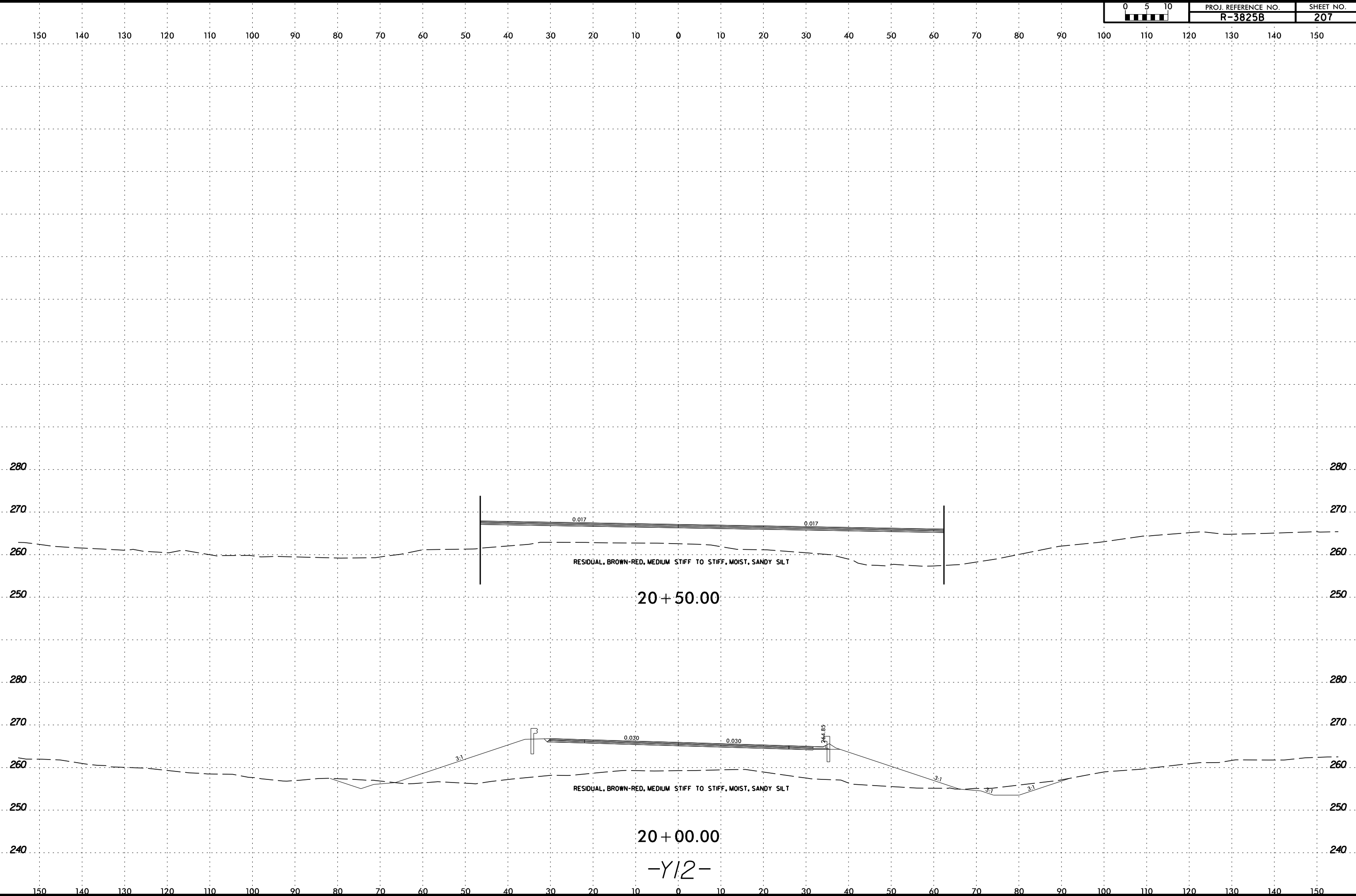

20 + 50.00

RESIDUAL, BROWN-RED, MEDIUM STIFF TO STIFF, MOIST, SANDY SILT

20 + 00.00

RESIDUAL, BROWN-RED, MEDIUM STIFF TO STIFF, MOIST, SANDY SILT

-Y12-

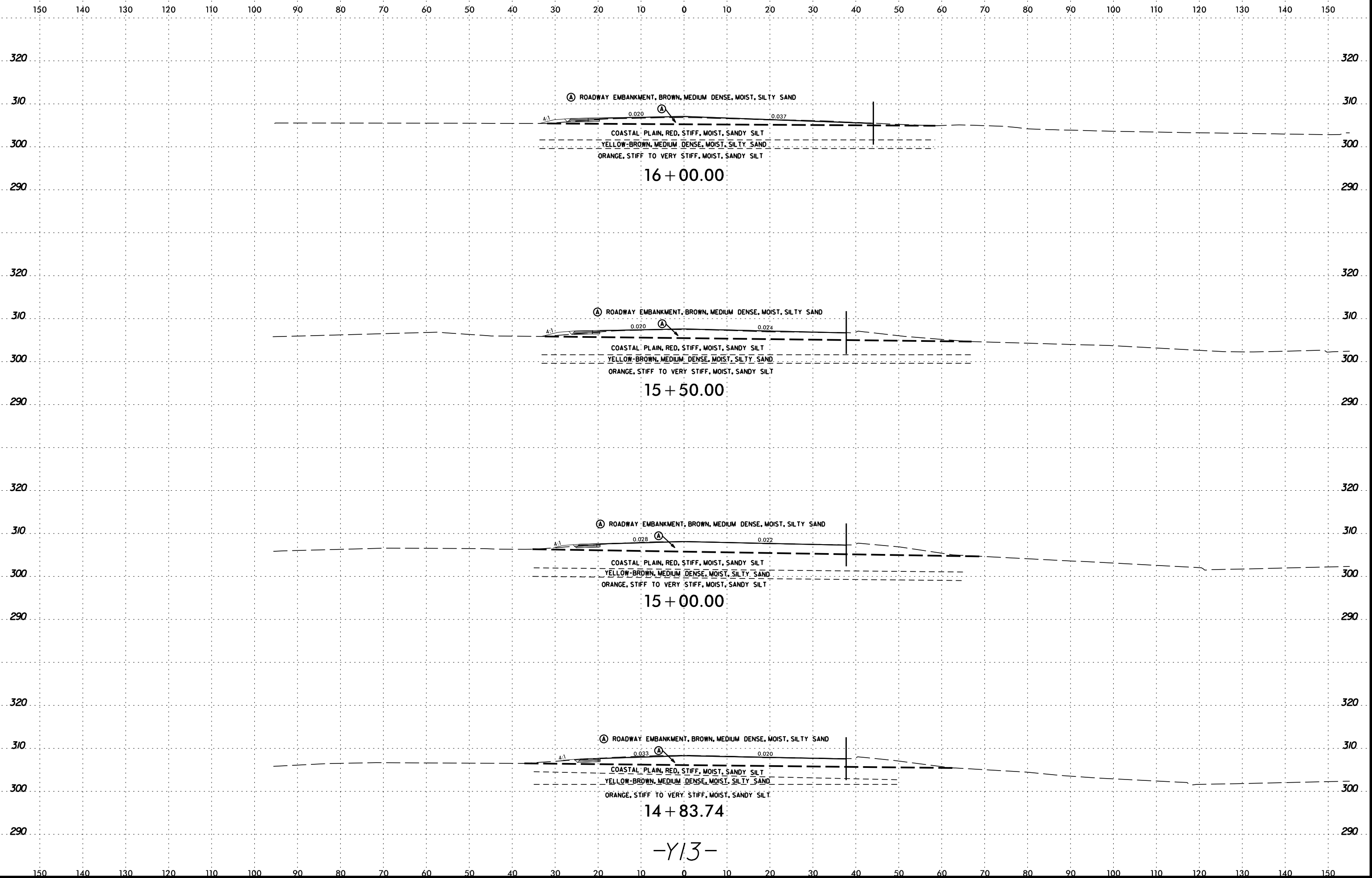

-Y13-

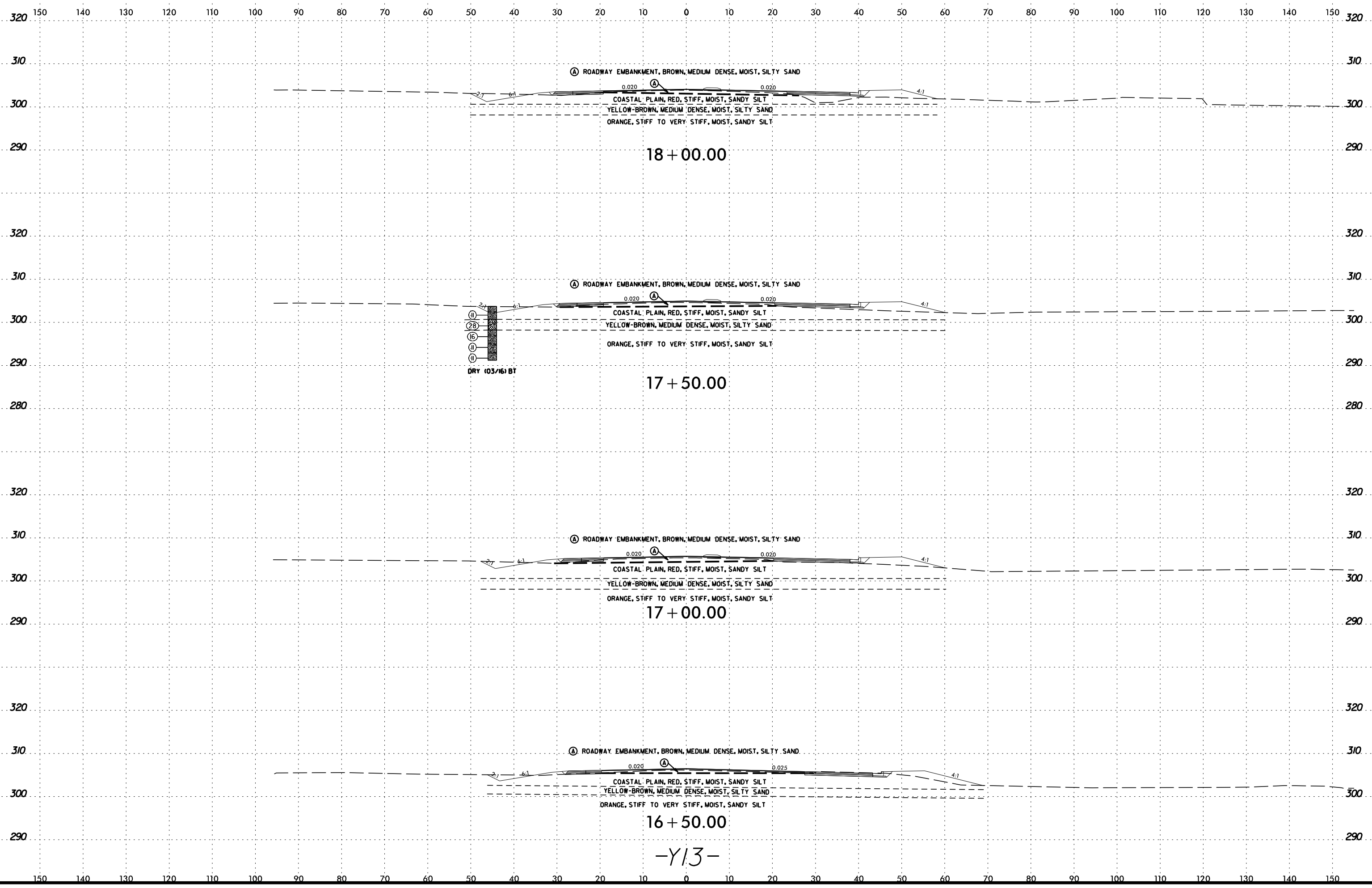

16+50.00

17+00.00

17+50.00

18+00.00

-Y13-

6/23/16

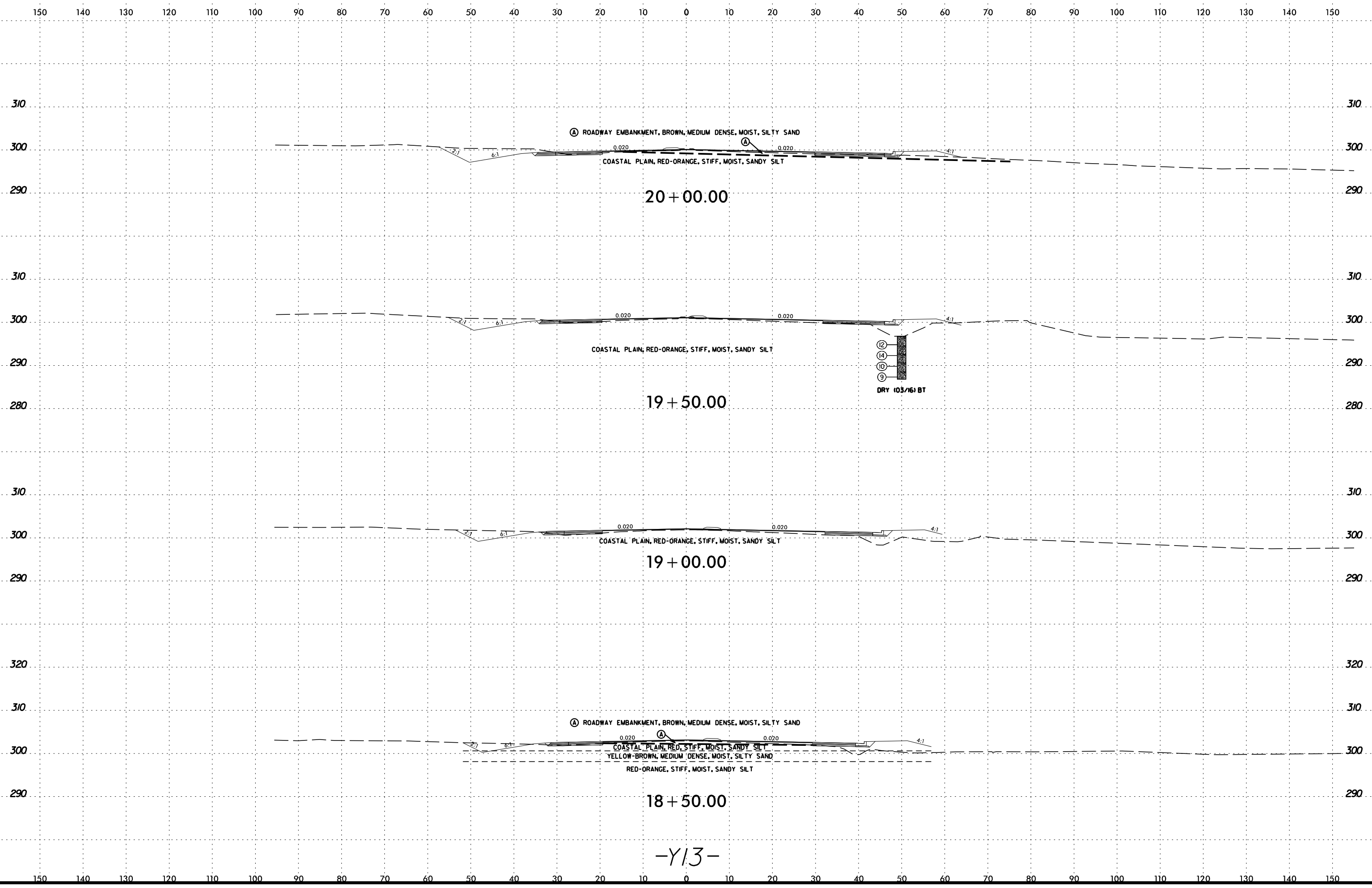

2/23/2017  
M:\N\NCD01\R-3825B\R-3825B.GEO...RDWY...modif\ter\CA00D\_GEO\TECH\sc\R3825B\_Geo\_xst\_yl3.dgn  
C:\ur\lmgton

-Y13-

6/23/16

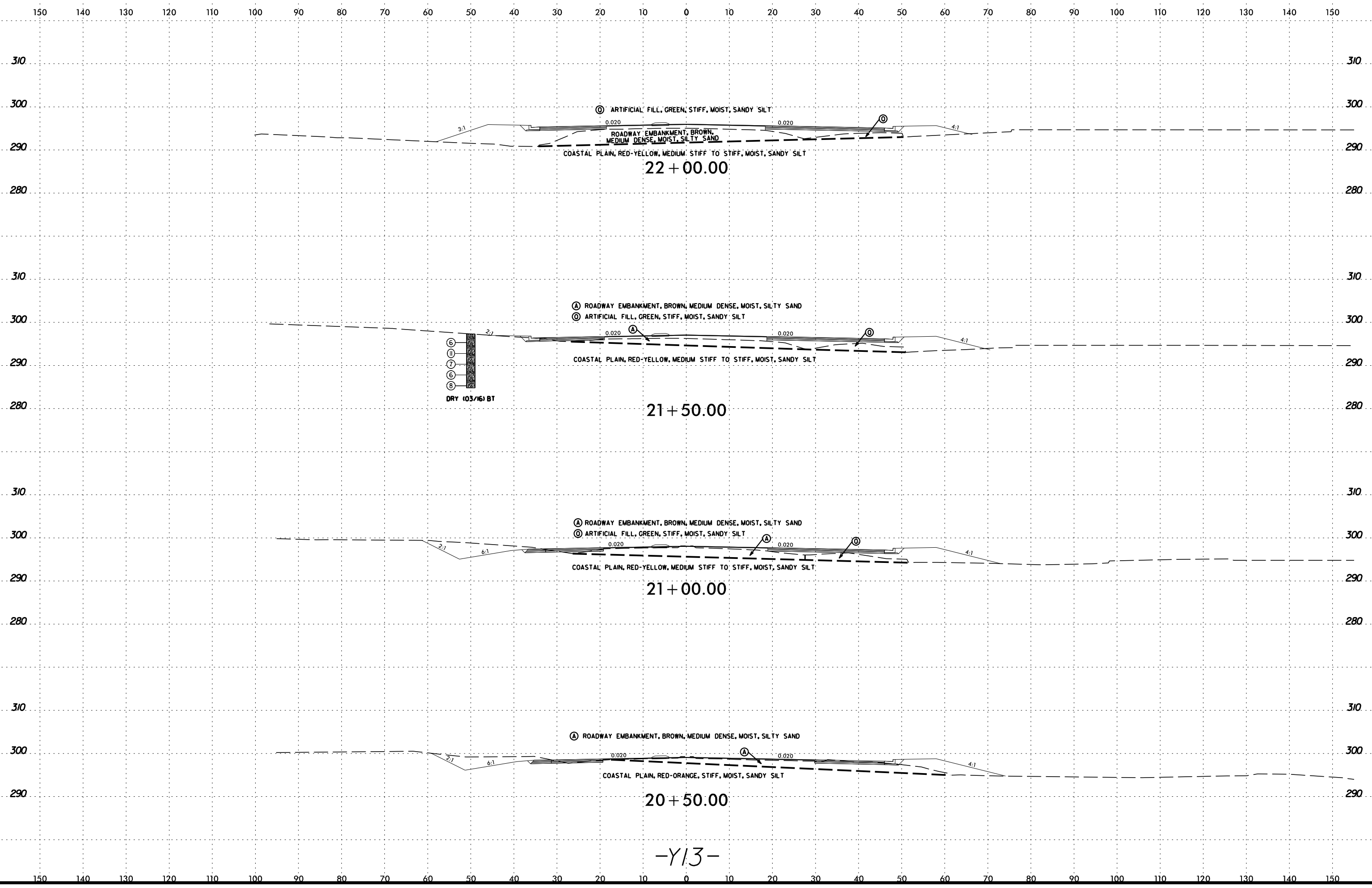

-Y13-

2/23/2017  
M:\N\NCD01\R-3825B\R-3825B.GEO.RDWAY.modifier\CA00.GEOTECH\sc\VR3825B\_Geo\_xsi.jl3.dgn



6/23/16

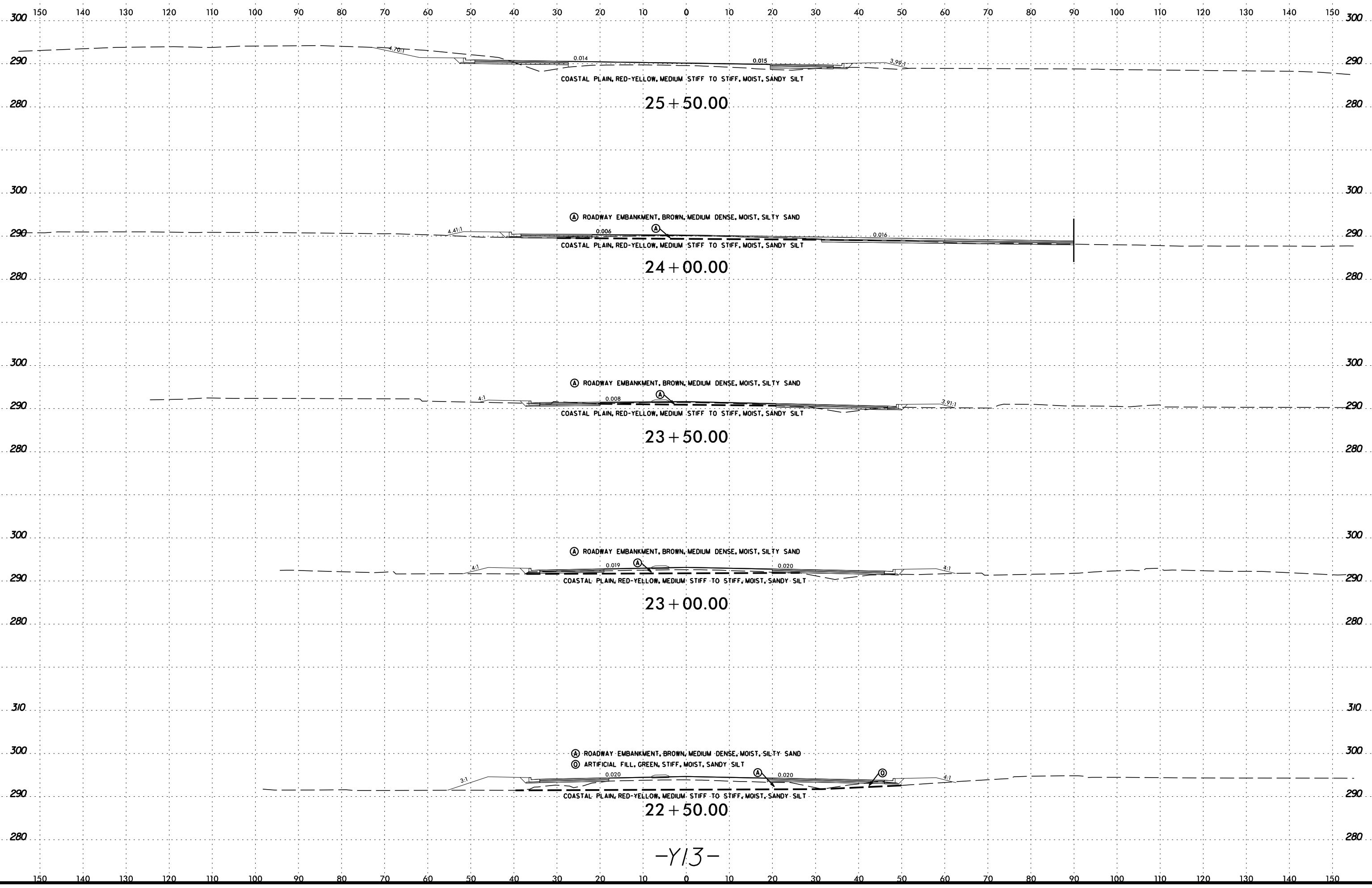

2/23/2017  
M:\N\NCD001\R-3825B\R-3825B\_GEO\_RDWY.mxd  
C:\Users\j3.dgn

22 + 50.00

23 + 00.00

23 + 50.00

24 + 00.00

25 + 50.00

-Y13-

6/23/16

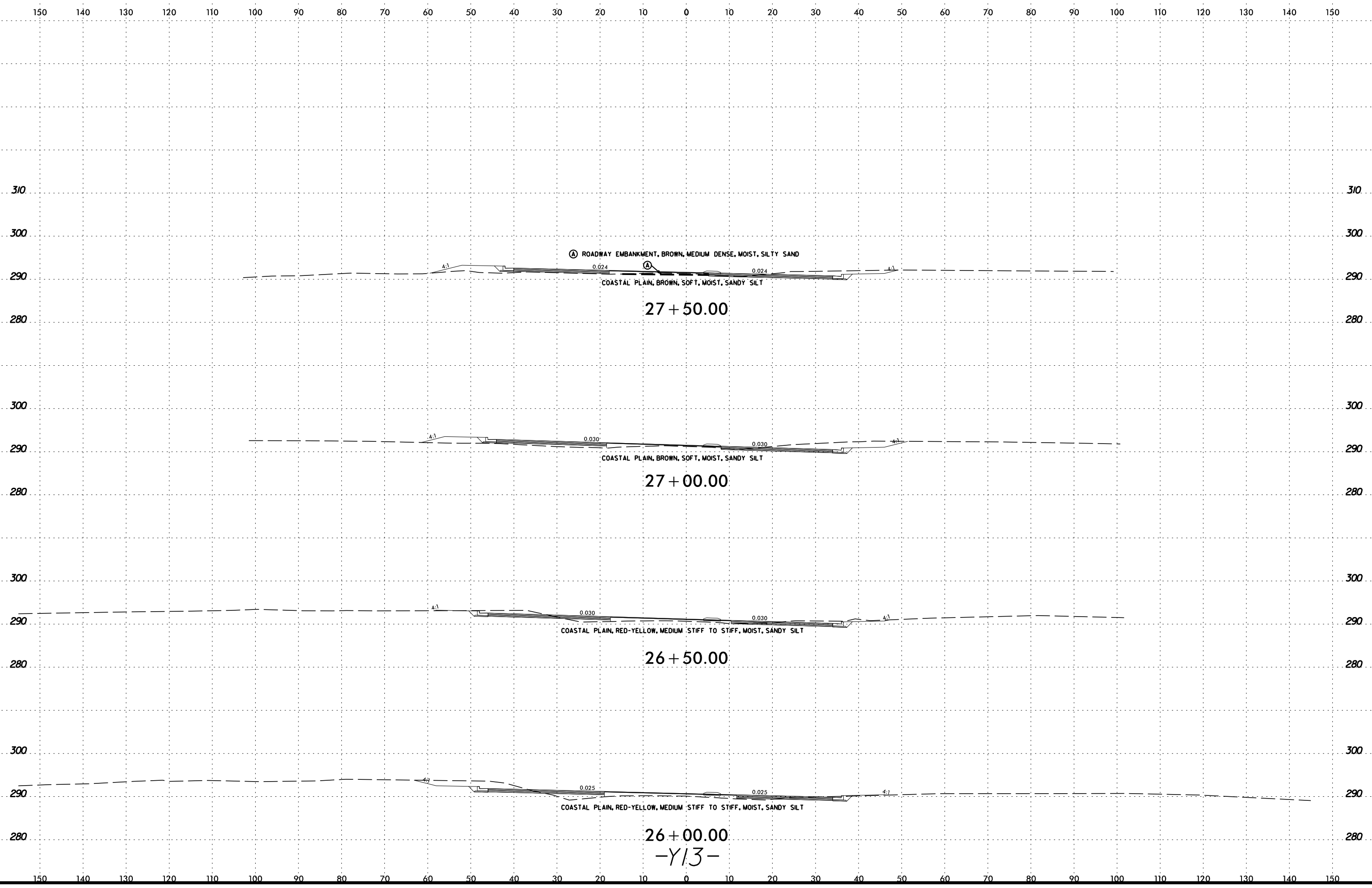

2/23/2017  
M:\N\NCD01\R-3825B\R-3825B\_GEO\_RDWY.mxd  
C:\Program Files\Autodesk\AutoCAD 2010\AutoCAD.exe

26+00.00  
-Y13-

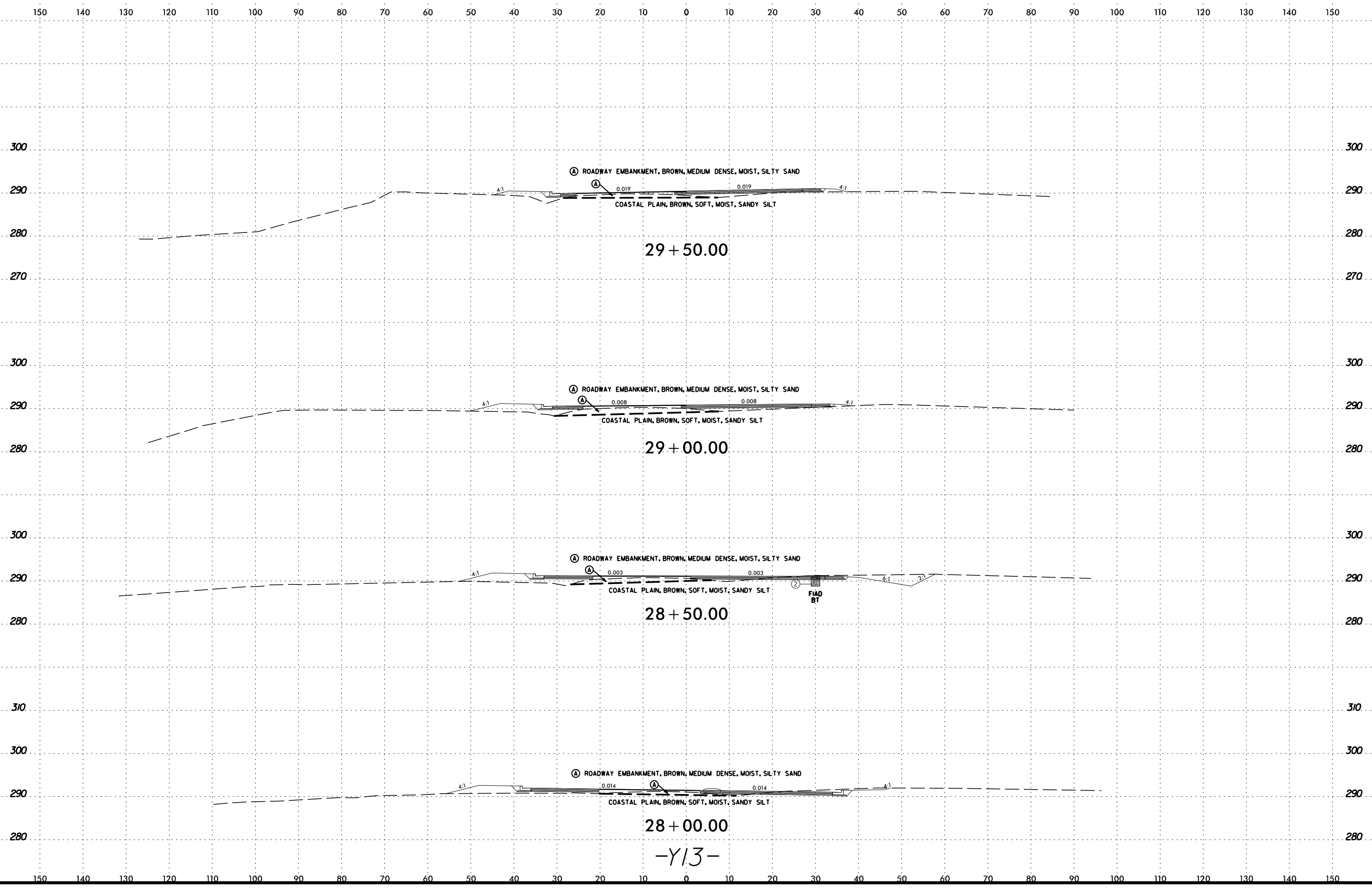

29 + 50.00

29 + 00.00

28 + 50.00

28 + 00.00

-Y13-

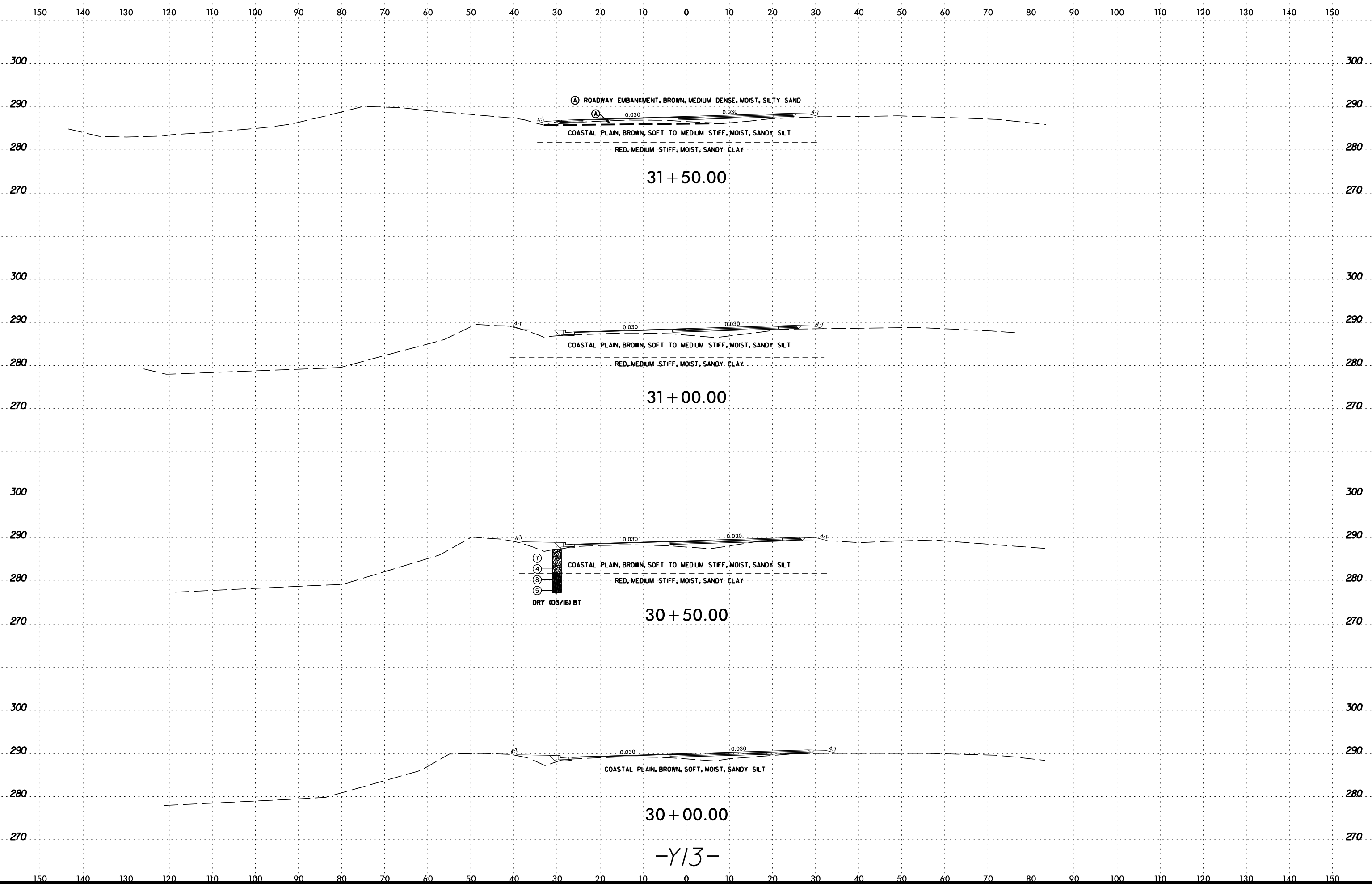

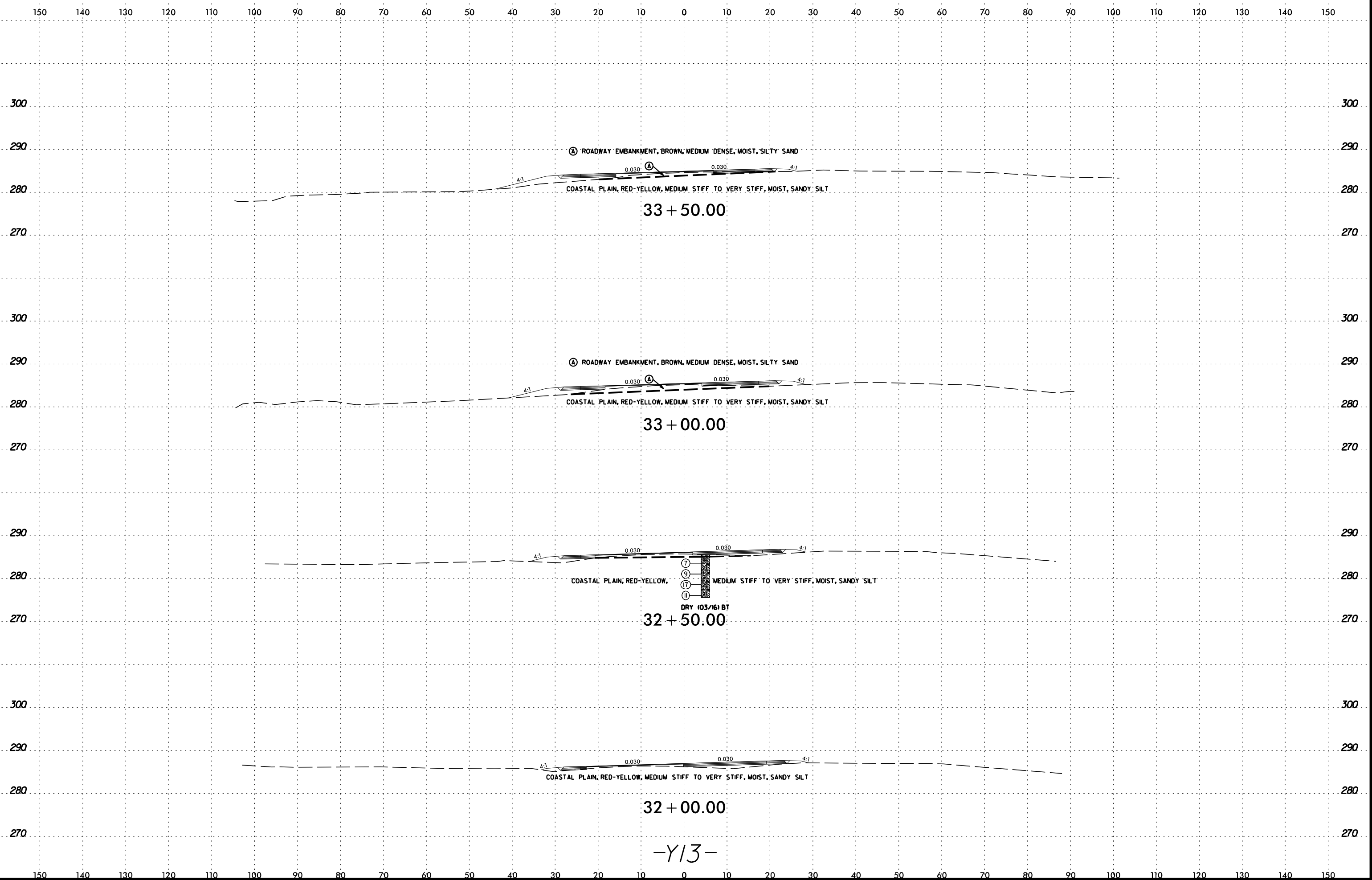

2/23/2017  
 M:\N\NCD01\R-3825B\R-3825B.GEO\_RDWY.mxd  
 C:\Users\j3\Documents

6/23/16

150 140 130 120 110 100 90 80 70 60 50 40 30 20 10 0 10 20 30 40 50 60 70 80 90 100 110 120 130 140 150

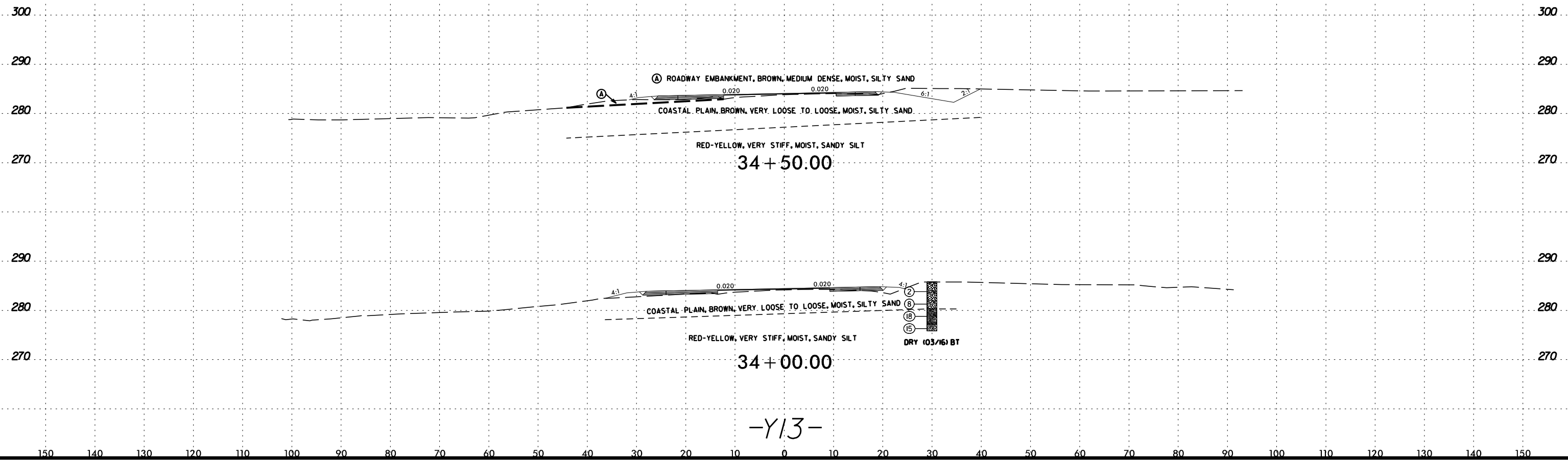

2/23/2017  
 M:\N\NCD01\R-3825B\R-3825B.GEO\_RDWY.mxd  
 C:\Program Files\Autodesk\AutoCAD 2017\AutoCAD.exe

REFERENCE: R-3825B

PROJECT: 34552

STATE OF NORTH CAROLINA  
DEPARTMENT OF TRANSPORTATION  
DIVISION OF HIGHWAYS  
GEOTECHNICAL ENGINEERING UNIT

STATE	STATE PROJECT REFERENCE NO.	SHEET NO.	TOTAL SHEETS
N.C.	R-3825B	1	9

**STRUCTURE**  
**SUBSURFACE INVESTIGATION**

**CONTENTS**

<u>SHEET NO.</u>	<u>DESCRIPTION</u>
1	TITLE SHEET
2	LEGEND (SOIL & ROCK)
2A	SUPPLEMENTAL LEGEND (GSI)
3	SITE PLAN
4-7	BORE LOG(S) & CORE REPORT(S)
8-9	CORE PHOTOGRAPHS)

COUNTY JOHNSTON

PROJECT DESCRIPTION NC 42 FROM EAST OF  
SR 1902 (GLEN LAUREL RD) TO SR 1003  
(BUFFALOE RD)

SITE DESCRIPTION PROPOSED UTILITIES EASEMENT

**CAUTION NOTICE**

THE SUBSURFACE INFORMATION AND THE SUBSURFACE INVESTIGATION ON WHICH IT IS BASED WERE MADE FOR THE PURPOSE OF STUDY, PLANNING AND DESIGN, AND NOT FOR CONSTRUCTION OR PAY PURPOSES. THE VARIOUS FIELD BORING LOGS, ROCK CORES AND SOIL TEST DATA AVAILABLE MAY BE REVIEWED OR INSPECTED IN RALEIGH BY CONTACTING THE N. C. DEPARTMENT OF TRANSPORTATION, GEOTECHNICAL ENGINEERING UNIT AT (919) 707-6850. THE SUBSURFACE PLANS AND REPORTS, FIELD BORING LOGS, ROCK CORES AND SOIL TEST DATA ARE NOT PART OF THE CONTRACT.

GENERAL SOIL AND ROCK STRATA DESCRIPTIONS AND INDICATED BOUNDARIES ARE BASED ON A GEOTECHNICAL INTERPRETATION OF ALL AVAILABLE SUBSURFACE DATA AND MAY NOT NECESSARILY REFLECT THE ACTUAL SUBSURFACE CONDITIONS BETWEEN BORINGS OR BETWEEN SAMPLED STRATA WITHIN THE BOREHOLE. THE LABORATORY SAMPLE DATA AND THE IN SITU (IN-PLACE) TEST DATA CAN BE RELIED ON ONLY TO THE DEGREE OF RELIABILITY INHERENT IN THE STANDARD TEST METHOD. THE OBSERVED WATER LEVELS OR SOIL MOISTURE CONDITIONS INDICATED IN THE SUBSURFACE INVESTIGATIONS ARE AS RECORDED AT THE TIME OF THE INVESTIGATION. THESE WATER LEVELS OR SOIL MOISTURE CONDITIONS MAY VARY CONSIDERABLY WITH TIME ACCORDING TO CLIMATIC CONDITIONS INCLUDING TEMPERATURES, PRECIPITATION AND WIND, AS WELL AS OTHER NON-CLIMATIC FACTORS.

THE BIDDER OR CONTRACTOR IS CAUTIONED THAT DETAILS SHOWN ON THE SUBSURFACE PLANS ARE PRELIMINARY ONLY AND IN MANY CASES THE FINAL DESIGN DETAILS ARE DIFFERENT. FOR BIDDING AND CONSTRUCTION PURPOSES, REFER TO THE CONSTRUCTION PLANS AND DOCUMENTS FOR FINAL DESIGN INFORMATION ON THIS PROJECT. THE DEPARTMENT DOES NOT WARRANT OR GUARANTEE THE SUFFICIENCY OR ACCURACY OF THE INVESTIGATION MADE, NOR THE INTERPRETATIONS MADE, OR OPINION OF THE DEPARTMENT AS TO THE TYPE OF MATERIALS AND CONDITIONS TO BE ENCOUNTERED. THE BIDDER OR CONTRACTOR IS CAUTIONED TO MAKE SUCH INDEPENDENT SUBSURFACE INVESTIGATIONS AS HE DEEMS NECESSARY TO SATISFY HIMSELF AS TO CONDITIONS TO BE ENCOUNTERED ON THE PROJECT. THE CONTRACTOR SHALL HAVE NO CLAIM FOR ADDITIONAL COMPENSATION OR FOR AN EXTENSION OF TIME FOR ANY REASON RESULTING FROM THE ACTUAL CONDITIONS ENCOUNTERED AT THE SITE DIFFERING FROM THOSE INDICATED IN THE SUBSURFACE INFORMATION.

- NOTES:
1. THE INFORMATION CONTAINED HEREIN IS NOT IMPLIED OR GUARANTEED BY THE N. C. DEPARTMENT OF TRANSPORTATION AS ACCURATE NOR IS IT CONSIDERED PART OF THE PLANS, SPECIFICATIONS OR CONTRACT FOR THE PROJECT.
  2. BY HAVING REQUESTED THIS INFORMATION, THE CONTRACTOR SPECIFICALLY WAIVES ANY CLAIMS FOR INCREASED COMPENSATION OR EXTENSION OF TIME BASED ON DIFFERENCES BETWEEN THE CONDITIONS INDICATED HEREIN AND THE ACTUAL CONDITIONS AT THE PROJECT SITE.

PERSONNEL

\_\_\_\_\_  
\_\_\_\_\_  
\_\_\_\_\_  
N. O. MOORE  
\_\_\_\_\_  
A. N. KINTNER  
\_\_\_\_\_  
D. G. PINTER  
\_\_\_\_\_  
R. E. CLARKE

INVESTIGATED BY J. L. LOVE

DRAWN BY A. N. KINTNER

CHECKED BY C. A. KREIDER

SUBMITTED BY J. L. LOVE

DATE FEBRUARY 2018

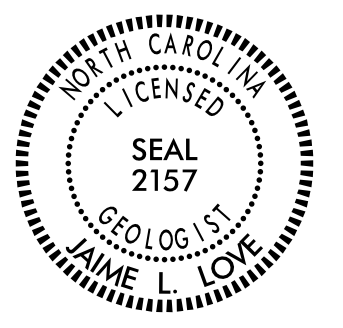

DocuSigned by:  
Jaime L. Love 2/15/2018

\_\_\_\_\_  
SIGNATURE DATE

**DOCUMENT NOT CONSIDERED FINAL  
UNLESS ALL SIGNATURES COMPLETED**

NORTH CAROLINA DEPARTMENT OF TRANSPORTATION
DIVISION OF HIGHWAYS
GEOTECHNICAL ENGINEERING UNIT
SUBSURFACE INVESTIGATION

SOIL AND ROCK LEGEND, TERMS, SYMBOLS, AND ABBREVIATIONS

Table with columns: SOIL DESCRIPTION, GRADATION, ROCK DESCRIPTION, TERMS AND DEFINITIONS. Includes sub-sections like SOIL LEGEND AND AASHTO CLASSIFICATION, CONSISTENCY OR DENSENESS, TEXTURE OR GRAIN SIZE, SOIL MOISTURE - CORRELATION OF TERMS, PLASTICITY, COLOR, MISCELLANEOUS SYMBOLS, RECOMMENDATION SYMBOLS, ABBREVIATIONS, EQUIPMENT USED ON SUBJECT PROJECT, FRACTURE SPACING, BEDDING, INDURATION.











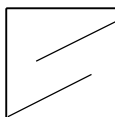
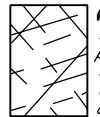
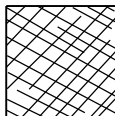
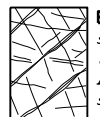

NORTH CAROLINA DEPARTMENT OF TRANSPORTATION  
DIVISION OF HIGHWAYS  
GEOTECHNICAL ENGINEERING UNIT

**SUBSURFACE INVESTIGATION**

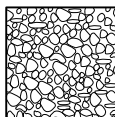
SUPPLEMENTAL LEGEND, GEOLOGICAL STRENGTH INDEX (GSI) TABLES  
FROM AASHTO LRFD BRIDGE DESIGN SPECIFICATIONS

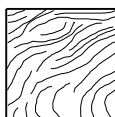
AASHTO LRFD Figure 10.4.6.4-1 — Determination of GSI for Jointed Rock Mass (Marinos and Hoek, 2000)

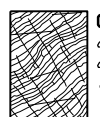
AASHTO LRFD Figure 10.4.6.4-2 — Determination of GSI for Tectonically Deformed Heterogeneous Rock Masses (Marinos and Hoek, 2000)

GEOLOGICAL STRENGTH INDEX (GSI) FOR JOINTED ROCKS (Hoek and Marinos, 2000)		SURFACE CONDITIONS					GSI FOR HETEROGENEOUS ROCK MASSES SUCH AS FLYSCH (Marinos, P and Hoek E., 2000)		SURFACE CONDITIONS OF DISCONTINUITIES (Predominantly bedding planes)				
From the lithology, structure and surface conditions of the discontinuities, estimate the average value of GSI. Do not try to be too precise. Quoting a range from 33 to 37 is more realistic than stating that GSI = 35. Note that the table does not apply to structurally controlled failures. Where weak planar structural planes are present in an unfavorable orientation with respect to the excavation face, these will dominate the rock mass behaviour. The shear strength of surfaces in rocks that are prone to deterioration as a result of changes in moisture content will be reduced if water is present. When working with rocks in the fair to very poor categories, a shift to the right may be made for wet conditions. Water pressure is dealt with by effective stress analysis.		VERY GOOD Very rough, fresh unweathered surfaces	GOOD Rough, slightly weathered, iron stained surfaces	FAIR Smooth, moderately weathered and altered surfaces	POOR Slickensided, highly weathered surfaces with compact coatings or fillings or angular fragments	VERY POOR Slickensided, highly weathered surfaces with soft clay coatings or fillings	From a description of the lithology, structure and surface conditions (particularly of the bedding planes), choose a box in the chart. Locate the position in the box that corresponds to the condition of the discontinuities and estimate the average value of GSI from the contours. Do not attempt to be too precise. Quoting a range from 33 to 37 is more realistic than giving GSI = 35. Note that the Hoek-Brown criterion does not apply to structurally controlled failures. Where unfavourably oriented continuous weak planar discontinuities are present, these will dominate the behaviour of the rock mass. The strength of some rock masses is reduced by the presence of groundwater and this can be allowed for by a slight shift to the right in the columns for fair, poor and very poor conditions. Water pressure does not change the value of GSI and it is dealt with by using effective stress analysis.	VERY GOOD - Very Rough, fresh unweathered surfaces	GOOD - Rough, slightly weathered surfaces	FAIR - Smooth, moderately weathered and altered surfaces	POOR - Very smooth, occasionally slickensided surfaces with compact coatings or fillings with angular fragments	VERY POOR - Very smooth, slickensided or highly weathered surfaces with soft clay coatings or fillings	
STRUCTURE		DECREASING SURFACE QUALITY →					COMPOSITION AND STRUCTURE						
 INTACT OR MASSIVE - intact rock specimens or massive in situ rock with few widely spaced discontinuities		90			N/A	N/A	 <b>A.</b> Thick bedded, very blocky sandstone The effect of pelitic coatings on the bedding planes is minimized by the confinement of the rock mass. In shallow tunnels or slopes these bedding planes may cause structurally controlled instability.	70					
 BLOCKY - well interlocked undisturbed rock mass consisting of cubical blocks formed by three intersecting discontinuity sets		80					 <b>B.</b> Sandstone with thin inter-layers of siltstone	60					
 VERY BLOCKY - interlocked, partially disturbed mass with multi-faceted angular blocks formed by 4 or more joint sets			70				 <b>C.</b> Sandstone and siltstone in similar amounts		50				
 BLOCKY/DISTURBED/SEAMY - folded with angular blocks formed by many intersecting discontinuity sets. Persistence of bedding planes or schistosity			60				 <b>D.</b> Siltstone or silty shale with sandstone layers		40				
 DISINTEGRATED - poorly interlocked, heavily broken rock mass with mixture of angular and rounded rock pieces			50				 <b>E.</b> Weak siltstone or clayey shale with sandstone layers		30				
 LAMINATED/SHEARED - Lack of blockiness due to close spacing of weak schistosity or shear planes			40				 <b>F.</b> Tectonically deformed, intensively folded/faulted, sheared clayey shale or siltstone with broken and deformed sandstone layers forming an almost chaotic structure		20				
			30				 <b>G.</b> Undisturbed silty or clayey shale with or without a few very thin sandstone layers		10				
			20				 <b>H.</b> Tectonically deformed silty or clayey shale forming a chaotic structure with pockets of clay. Thin layers of sandstone are transformed into small rock pieces.						
			10										
		N/A	N/A										

→ Means deformation after tectonic disturbance

# SITE PLAN

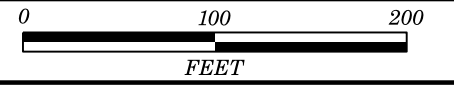

NAD 83/2011

60+00

65+00

70+00

BY3-140

-L- POT Sta. 68+11.45 =  
-Y6- POT Sta. 17+91.45

BM#4  
N: 691,147  
E: 2,176,708  
ELEV=140.97'

L.6310

L.6686

L.6520

L.6520

L.6520

-DRW3-POT Sta. 10+00.00 =  
-L-POT Sta. 67+78.51

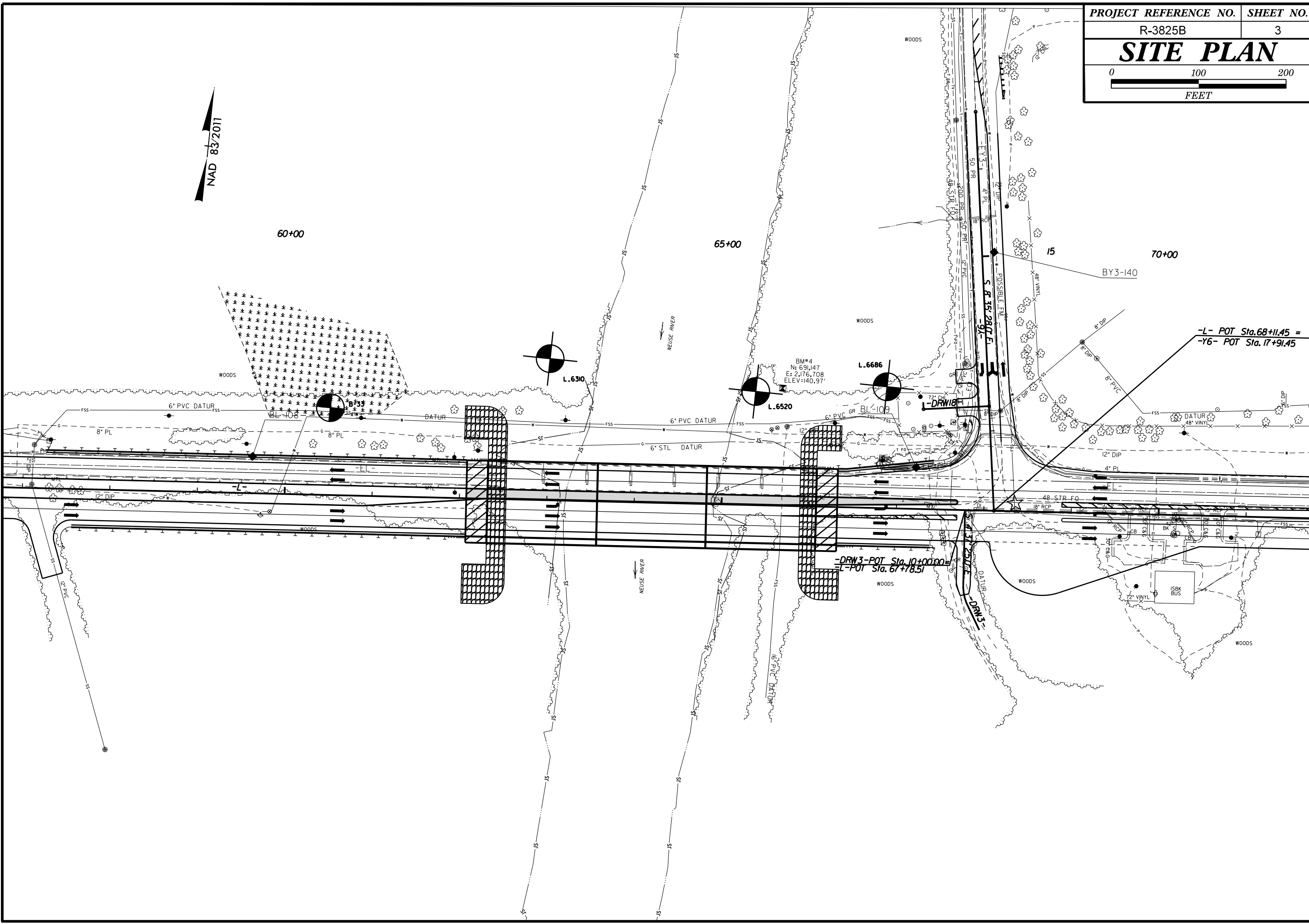

# GEOTECHNICAL BORING REPORT

## BORE LOG

WBS 34552.1.FR3		TIP R-3825B		COUNTY JOHNSTON		GEOLOGIST MARCELO MEDEIROS										
SITE DESCRIPTION NC-42 From East of SR1902 to SR1003							GROUND WTR (ft)									
BORING NO. B-33		STATION 60+50		OFFSET 100 ft LT		ALIGNMENT -L-										
COLLAR ELEV. 139.7 ft		TOTAL DEPTH 14.3 ft		NORTHING 691,070		EASTING 2,176,196										
DRILL RIG/HAMMER EFF./DATE BRI9910 BK-51 75% 06/03/2015				DRILL METHOD H.S. Augers		HAMMER TYPE Automatic										
DRILLER Contract Driller		START DATE 03/07/16		COMP. DATE 03/07/16		SURFACE WATER DEPTH N/A										
ELEV (ft)	DRIVE ELEV (ft)	DEPTH (ft)	BLOW COUNT			BLOWS PER FOOT					SAMP. NO.	LOG	SOIL AND ROCK DESCRIPTION			
			0.5ft	0.5ft	0.5ft	0	25	50	75	100			ELEV. (ft)	DEPTH (ft)		
140														139.7	GROUND SURFACE	0.0
	138.7	1.0	2	2	4								M	136.7	<b>ALLUVIAL</b> BROWN, CLAYEY SILT WITH TRACE MICA	3.0
135	136.2	3.5	2	4	5								M		TAN-BROWN, SANDY CLAY	
	133.7	6.0	2	2	3								M			
	131.2	8.5	2	2	3								M			
130	129.7	10.0	6	100/0.3									M	129.7	<b>WEATHERED ROCK</b> (SCHIST)	10.0
														125.4		14.3
Boring Terminated at Elevation 125.4 ft IN WEATHERED ROCK (SCHIST) BORING DRILLED DURING ROADWAY INVESTIGATION BY GEOSYNTEC.																

NCDOT BORE DOUBLE R3825\_GEO\_UTILITIES.GPJ NC\_DOT.GDT 2/15/18

# GEOTECHNICAL BORING REPORT BORE LOG

# GEOTECHNICAL BORING REPORT CORE LOG

WBS 34552.1.FR3		TIP R-3825B		COUNTY JOHNSTON		GEOLOGIST Kintner, A. N.											
SITE DESCRIPTION UTILITIES AT NEUSE RIVER BRIDGE ON NC 42							GROUND WTR (ft)										
BORING NO. L_6310		STATION 63+00		OFFSET 162 ft LT		ALIGNMENT -L-											
COLLAR ELEV. 139.8 ft		TOTAL DEPTH 30.5 ft		NORTHING 691,152		EASTING 2,176,440											
DRILL RIG/HAMMER EFF./DATE RFO0074 CME-55 86% 11/17/2017			DRILL METHOD NW Casing W/SPT & Core			HAMMER TYPE Automatic											
DRILLER Pinter, D. G.		START DATE 02/08/18		COMP. DATE 02/08/18		SURFACE WATER DEPTH N/A											
ELEV (ft)	DRIVE ELEV (ft)	DEPTH (ft)	BLOW COUNT			BLOWS PER FOOT					SAMP. NO.	MOI	LOG	SOIL AND ROCK DESCRIPTION			
			0.5ft	0.5ft	0.5ft	0	25	50	75	100				ELEV. (ft)	DEPTH (ft)		
140															139.8	0.0	GROUND SURFACE
															138.3	1.5	TOPSOIL AND ROOT MAT
135	136.1	3.7	4	6	6								M				ALLUVIAL TAN-BROWN-ORANGE TO GRAY, SILTY SAND WITH TRACE MICA AND TRACE TO LITTLE ORGANICS AND WOOD FRAGMENTS
130	131.1	8.7	4	5	5								M				
125	126.1	13.7	1	2	4								M				
120	121.1	18.7	60/0.1												121.1	18.7	WEATHERED ROCK (GNEISS)
														121.0	18.8	CRYSTALLINE ROCK (GNEISS)	
115																	DARK GREEN AND DARK GRAY, VERY SLIGHT WEATHERING TO FRESH, HARD TO VERY HARD, CLOSE TO MODERATELY CLOSE FRACTURE SPACING, GNEISS
110																	REC=100% RQD=75% GSI=75-80
															109.3	30.5	Boring Terminated at Elevation 109.3 ft IN CRYSTALLINE ROCK (GNEISS)

WBS 34552.1.FR3		TIP R-3825B		COUNTY JOHNSTON		GEOLOGIST Kintner, A. N.					
SITE DESCRIPTION UTILITIES AT NEUSE RIVER BRIDGE ON NC 42							GROUND WTR (ft)				
BORING NO. L_6310		STATION 63+00		OFFSET 162 ft LT		ALIGNMENT -L-					
COLLAR ELEV. 139.8 ft		TOTAL DEPTH 30.5 ft		NORTHING 691,152		EASTING 2,176,440					
DRILL RIG/HAMMER EFF./DATE RFO0074 CME-55 86% 11/17/2017			DRILL METHOD NW Casing W/SPT & Core			HAMMER TYPE Automatic					
DRILLER Pinter, D. G.		START DATE 02/08/18		COMP. DATE 02/08/18		SURFACE WATER DEPTH N/A					
CORE SIZE NXWL			TOTAL RUN 11.7 ft								
ELEV (ft)	RUN ELEV (ft)	DEPTH (ft)	RUN (ft)	DRILL RATE (Min/ft)	RUN		SAMP. NO.	STRATA		LOG	DESCRIPTION AND REMARKS
					REC. (ft) %	RQD (ft) %		REC. (ft) %	RQD (ft) %		
121.02											Begin Coring @ 18.8 ft
120	121.0	18.8	1.7	1:10/0.7	(1.7)	(0.8)		(11.7)	(8.8)		DARK GREEN AND DARK GRAY, VERY SLIGHT WEATHERING TO FRESH, HARD TO VERY HARD, CLOSE TO MODERATELY CLOSE FRACTURE SPACING, GNEISS  GSI=75-80
	119.3	20.5	5.0	2:17/1.0	100%	47%					
				1:59/1.0	(5.0)	(4.0)					
115				2:58/1.0	100%	80%					
	114.3	25.5	5.0	3:15/1.0	(5.0)	(4.0)					
				2:57/1.0							
110				2:45/1.0	100%	80%					
				3:13/1.0							
				3:41/1.0							
	109.3	30.5		3:52/1.0							
				2:47/1.0							
											Boring Terminated at Elevation 109.3 ft IN CRYSTALLINE ROCK (GNEISS)

**GEOTECHNICAL BORING REPORT  
BORE LOG**

**GEOTECHNICAL BORING REPORT  
CORE LOG**

<b>WBS</b> 34552.1.FR3				<b>TIP</b> R-3825B				<b>COUNTY</b> JOHNSTON				<b>GEOLOGIST</b> Kintner, A. N.					
<b>SITE DESCRIPTION</b> UTILITIES AT NEUSE RIVER BRIDGE ON NC 42										<b>GROUND WTR (ft)</b>							
<b>BORING NO.</b> L_6520			<b>STATION</b> 65+36			<b>OFFSET</b> 130 ft LT			<b>ALIGNMENT</b> -L-			<b>0 HR.</b> 6.2					
<b>COLLAR ELEV.</b> 136.6 ft			<b>TOTAL DEPTH</b> 30.4 ft			<b>NORTHING</b> 691,139			<b>EASTING</b> 2,176,678			<b>24 HR.</b> FIAD					
<b>DRILL RIG/HAMMER EFF./DATE</b> RFO0074 CME-55 86% 11/17/2017						<b>DRILL METHOD</b> NW Casing w/ Core						<b>HAMMER TYPE</b> Automatic					
<b>DRILLER</b> Pinter, D. G.				<b>START DATE</b> 01/26/18				<b>COMP. DATE</b> 01/26/18				<b>SURFACE WATER DEPTH</b> N/A					
ELEV (ft)	DRIVE ELEV (ft)	DEPTH (ft)	BLOW COUNT			BLOWS PER FOOT					SAMP. NO.	LOG	SOIL AND ROCK DESCRIPTION	DEPTH (ft)			
			0.5ft	0.5ft	0.5ft	0	25	50	75	100							
140														GROUND SURFACE	0.0		
135	133.1	3.5										M	ALLUVIAL GRAY, SANDY SILT WITH TRACE MICA AND WOOD FRAGMENTS				
130			2	1	1												
125	128.1	8.5	WOH	WOH	1							M	WEATHERED ROCK (SCHIST)	10.2			
120	123.1	13.5	100/0.3							100/0.3			WEATHERED ROCK PALE GREEN-BROWN, SEVERE WEATHERING, CLOSE FRACTURE SPACING, SOFT TO MODERATELY HARD, AMPHIBOLITE	13.8			
115													CRUSTALINE ROCK DARK GREEN GRAY, VERY SLIGHT WEATHERING TO FRESH, MODERATELY CLOSE TO WIDE FRACTURE SPACING, MODERATELY HARD TO HARD, AMPHIBOLITE	18.7			
110													REC=49% CRUSTALINE ROCK				
													REC=99% RQD=99% GSI=70-75	30.4			
													Boring Terminated at Elevation 106.2 ft IN CRYSTALLINE ROCK (AMPHIBOLITE)				

<b>WBS</b> 34552.1.FR3				<b>TIP</b> R-3825B				<b>COUNTY</b> JOHNSTON				<b>GEOLOGIST</b> Kintner, A. N.					
<b>SITE DESCRIPTION</b> UTILITIES AT NEUSE RIVER BRIDGE ON NC 42										<b>GROUND WTR (ft)</b>							
<b>BORING NO.</b> L_6520			<b>STATION</b> 65+36			<b>OFFSET</b> 130 ft LT			<b>ALIGNMENT</b> -L-			<b>0 HR.</b> 6.2					
<b>COLLAR ELEV.</b> 136.6 ft			<b>TOTAL DEPTH</b> 30.4 ft			<b>NORTHING</b> 691,139			<b>EASTING</b> 2,176,678			<b>24 HR.</b> FIAD					
<b>DRILL RIG/HAMMER EFF./DATE</b> RFO0074 CME-55 86% 11/17/2017						<b>DRILL METHOD</b> NW Casing w/ Core						<b>HAMMER TYPE</b> Automatic					
<b>DRILLER</b> Pinter, D. G.				<b>START DATE</b> 01/26/18				<b>COMP. DATE</b> 01/26/18				<b>SURFACE WATER DEPTH</b> N/A					
ELEV (ft)	RUN ELEV (ft)	DEPTH (ft)	RUN (ft)	DRILL RATE (Min/ft)	RUN		SAMP. NO.	STRATA		LOG	DESCRIPTION AND REMARKS	DEPTH (ft)					
					REC (ft) %	RQD (ft) %		REC (ft) %	RQD (ft) %								
122.83	122.8	13.8	1.6	0:35/0.6 0:59/1.0	(0.4) 25%	(0.0) 0%		(2.4) 49%			Begin Coring @ 13.8 ft						
120	121.2	15.4	5.0	1:03/1.0 1:08/1.0 1:01/1.0 1:49/1.0 1:59/1.0	(3.7) 74%	(1.7) 34%		(11.6) 99%	(11.6) 99%		WEATHERED ROCK PALE GREEN-BROWN, SEVERE WEATHERING, CLOSE FRACTURE SPACING, SOFT TO MODERATELY HARD, AMPHIBOLITE	13.8					
115	116.2	20.4	5.0	1:59/1.0 2:11/1.0 2:06/1.0 2:08/1.0 2:11/1.0	(5.0) 100%	(5.0) 100%					CRYSTALLINE ROCK DARK GREEN GRAY, VERY SLIGHT WEATHERING TO FRESH, MODERATELY CLOSE TO WIDE FRACTURE SPACING, MODERATELY HARD TO HARD, AMPHIBOLITE	18.7					
110	111.2	25.4	5.0	1:56/1.0 2:14/1.0 2:10/1.0 2:11/1.0	(4.9) 98%	(4.9) 98%					GSI=70-75						
	106.2	30.4									Boring Terminated at Elevation 106.2 ft IN CRYSTALLINE ROCK (AMPHIBOLITE)	30.4					

NCDOT BORE DOUBLE R3825\_GEO UTILITIES.GPJ NC\_DOT.GDT 2/15/18

NCDOT BORE DOUBLE R3825\_GEO UTILITIES.GPJ NC\_DOT.GDT 2/15/18

# GEOTECHNICAL BORING REPORT BORE LOG

# GEOTECHNICAL BORING REPORT CORE LOG

WBS 34552.1.FR3		TIP R-3825B		COUNTY JOHNSTON		GEOLOGIST Kintner, A. N.										
SITE DESCRIPTION UTILITIES AT NEUSE RIVER BRIDGE ON NC 42							GROUND WTR (ft)									
BORING NO. L_6686		STATION 66+86		OFFSET 139 ft LT		ALIGNMENT -L-										
COLLAR ELEV. 149.8 ft		TOTAL DEPTH 40.2 ft		NORTHING 691,161		EASTING 2,176,827										
DRILL RIG/HAMMER EFF./DATE RFO0074 CME-55 86% 11/17/2017				DRILL METHOD NW Casing w/ Core		HAMMER TYPE Automatic										
DRILLER Pinter, D. G.		START DATE 01/30/18		COMP. DATE 01/30/18		SURFACE WATER DEPTH N/A										
ELEV (ft)	DRIVE ELEV (ft)	DEPTH (ft)	BLOW COUNT			BLOWS PER FOOT					SAMP. NO.	LOG MOI	LOG	SOIL AND ROCK DESCRIPTION		
			0.5ft	0.5ft	0.5ft	0	25	50	75	100				ELEV. (ft)	DEPTH (ft)	
150															149.8	GROUND SURFACE
																ALLUVIAL LIGHT GRAY AND ORANGE, CLAYEY SAND, WITH TRACE WELL-ROUNDED GRAVEL
145	146.3	3.5	6	11	15								M		143.8	RESIDUAL DARK GREEN-GRAY, SAPROLITIC, SANDY SILT WITH TRACE MICA
140	141.3	8.5	13	16	19								M			
135	136.3	13.5	13	22	73								M			
130	131.3	18.5	60/0.1												132.3	CRYSTALLINE ROCK (SCHIST)
															131.2	CRYSTALLINE ROCK DARK GREEN-GRAY, MODERATE TO VERY SLIGHT WEATHERING, CLOSE FRACTURE SPACING, SOFT TO HARD, SCHIST WITH SOME SEVERELY WEATHERED ZONES
																24.0-25.1 SEVERELY WEATHERED ZONE
																REC=77% RQD=9% GSI=30-40
110	109.7	40.1	60/0.1												109.6	Boring Terminated at Elevation 109.6 ft IN CRYSTALLINE ROCK (SCHIST)

WBS 34552.1.FR3		TIP R-3825B		COUNTY JOHNSTON		GEOLOGIST Kintner, A. N.						
SITE DESCRIPTION UTILITIES AT NEUSE RIVER BRIDGE ON NC 42							GROUND WTR (ft)					
BORING NO. L_6686		STATION 66+86		OFFSET 139 ft LT		ALIGNMENT -L-						
COLLAR ELEV. 149.8 ft		TOTAL DEPTH 40.2 ft		NORTHING 691,161		EASTING 2,176,827						
DRILL RIG/HAMMER EFF./DATE RFO0074 CME-55 86% 11/17/2017				DRILL METHOD NW Casing w/ Core		HAMMER TYPE Automatic						
DRILLER Pinter, D. G.		START DATE 01/30/18		COMP. DATE 01/30/18		SURFACE WATER DEPTH N/A						
CORE SIZE NXWL			TOTAL RUN 21.5 ft									
ELEV (ft)	RUN ELEV (ft)	DEPTH (ft)	RUN (ft)	DRILL RATE (Min/ft)	RUN		SAMP. NO.	STRATA		LOG	DESCRIPTION AND REMARKS	
					REC. (ft) %	RQD (ft) %		REC. (ft) %	RQD (ft) %		ELEV. (ft)	DEPTH (ft)
131.19												Begin Coring @ 18.6 ft
130	131.2	18.6	1.5	0:39/0.5	(1.0)	(0.0)		(16.6)	(2.0)		131.2	CRYSTALLINE ROCK DARK GREEN-GRAY, MODERATE TO VERY SLIGHT WEATHERING, CLOSE FRACTURE SPACING, SOFT TO HARD, SCHIST WITH SOME SEVERELY WEATHERED ZONES
	129.7	20.1	5.0	1:27/1.0	67%	0%		77%	9%			24.0-25.1 SEVERELY WEATHERED ZONE
				1:44/1.0	(3.9)	(0.9)						GSI=30-40
125	124.7	25.1	5.0	1:25/1.0	78%	18%						
				1:51/1.0								
				3:58/1.0								
120			5.0	1:29/1.0	(4.7)	(0.0)						
				1:58/1.0	94%	0%						
				2:13/1.0								
				1:42/1.0								
				1:51/1.0								
115	114.7	35.1	5.0	2:09/1.0	(3.3)	(0.7)						
				1:41/1.0	66%	14%						
				2:03/1.0								
				2:15/1.0								
				2:17/1.0								
110	109.7	40.1	5.0	2:09/1.0	(3.7)	(0.4)						
				1:54/1.0	74%	8%						
				3:05/1.0								
				3:34/1.0								
				4:21/1.0								
				N=60/0.1								
												Boring Terminated at Elevation 109.6 ft IN CRYSTALLINE ROCK (SCHIST)

NCDOT BORE DOUBLE R3825\_GEO\_UTILITIES.GPJ NC\_DOT.GDT 2/15/18

NCDOT BORE DOUBLE R3825\_GEO\_UTILITIES.GPJ NC\_DOT.GDT 2/15/18



# CORE PHOTOGRAPHS

## L\_6310

BOXES 1 & 2: 18.8 - 30.5 FEET

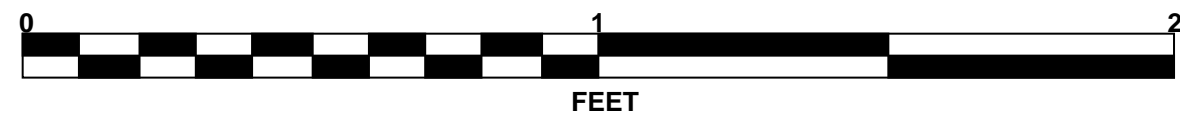

## L\_6520

BOXES 1 & 2: 13.8 - 30.4 FEET





# CORE PHOTOGRAPHS

**L\_6686**  
BOXES 1 & 2: 18.6 - 40.1 FEET

