

APPROVED: *Ayman Alqudwa*
F32AC5CAF985472...
 DATE: 6/5/2018

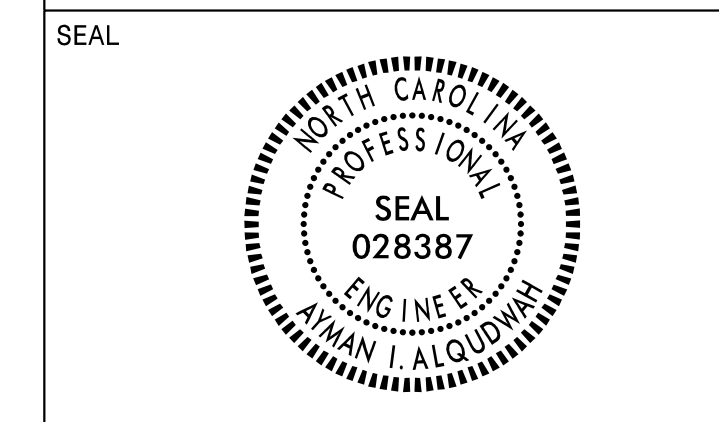

DOCUMENT NOT CONSIDERED FINAL UNLESS ALL SIGNATURES COMPLETED

R-3825B FINAL PAVEMENT MARKING SCHEDULE

SYMBOL	DESCRIPTION
	(FINAL PAVEMENT MARKINGS) THERMOPLASTIC (24", 120 MILS)
T2	WHITE STOPBAR THERMOPLASTIC (4", 90 MILS)
TA	WHITE EDGELINE
TB	YELLOW EDGELINE THERMOPLASTIC (4", 120 MILS)
T8	2 FT. - 6 FT./SP WHITE MINSKIP
T9	2 FT. - 6 FT./SP YELLOW MINSKIP
TC	10 FT. WHITE SKIP
TD	3 FT. - 9 FT./SP WHITE MINSKIP
TE	WHITE SOLD LANE LINE
TI	YELLOW DOUBLE CENTER THERMOPLASTIC (8", 90 MILS)
TP	YELLOW DIAGONAL THERMOPLASTIC (8", 120 MILS)
T13	3 FT. - 9 FT./SP WHITE MINSKIP
TQ	WHITE CROSSWALK LINE
TR	WHITE SOLD LANE LINE
	THERMOPLASTIC PAVEMENT MARKING SYMBOLS (90 MILS)
	UA - LEFT TURN ARROW
	UB - RIGHT TURN ARROW
	UC - STRAIGHT ARROW
	UD - COMBO LEFT/STRAIGHT ARROW
	UE - COMBO RIGHT/STRAIGHT ARROW
	UF - COMBO LEFT/RIGHT ARROW
	UG - COMBO LEFT/RIGHT/STRAIGHT ARROW
	UN - 24" YIELD LINE TRIANGLE
	UI - ALPHANUMERIC CHARACTER
	UP - MERGE ARROW
	UT - U-TURN ARROW
	(MARKERS) PERMANENT RAISED MARKERS
MA	YELLOW & YELLOW
MB	CRYSTAL & RED

SYMBOL	DESCRIPTION
	(FINAL PAVEMENT MARKINGS) THERMOPLASTIC (6", 90 MILS)
T6	WHITE EDGELINE
T7	YELLOW EDGELINE THERMOPLASTIC (6", 120 MILS)
T11	2 FT. - 6 FT./SP WHITE MINSKIP
T12	2 FT. - 6 FT./SP YELLOW MINSKIP
TJ	10 FT. WHITE SKIP
TK	3 FT. - 9 FT./SP WHITE MINSKIP
TL	WHITE SOLD LANE LINE
T16	YELLOW DOUBLE CENTER THERMOPLASTIC (12", 90 MILS)
TS	WHITE GORELINE
TU	WHITE DIAGONAL
TV	YELLOW DIAGONAL THERMOPLASTIC (12", 120 MILS)
TT	WHITE SOLD LANE LINE
T14	3 FT. - 9 FT./SP WHITE MINSKIP COLD APPLIED PLASTIC (6")
C6	WHITE EDGELINE
C7	YELLOW EDGELINE
CJ	10 FT. WHITE SKIP
CK	3 FT. - 9 FT./SP WHITE MINSKIP COLD APPLIED PLASTIC (12")
CS	WHITE GORELINE (MARKERS) SNOWPLOWABLE MARKERS
ME	YELLOW & YELLOW
MF	CRYSTAL & RED

06/05/18
 P:\TIP\Projects-R\R3825B\Traffic\Signing\CADD\PM Plan\R-3825b_pmp_psh_s01.dgn
 User:rtward

PAVEMENT MARKING SCHEDULE

TIP NO. R-3825B	SHEET NO. PMP-2
APPROVED: _____	
DATE: _____	
SEAL	
NOT A CERTIFIED DOCUMENT AS TO THE ORIGINAL DOCUMENT BUT ONLY AS TO THE REVISIONS - THIS DOCUMENT ORIGINALLY ISSUED AND SEALED BY AYMAN I. ALQUDWAH, 028387, ON 6/5/2018. THIS DOCUMENT IS ONLY CERTIFIED AS TO THE REVISIONS.	
DOCUMENT NOT CONSIDERED FINAL UNLESS ALL SIGNATURES COMPLETED	

SEAL APPLIES TO THE PLAN REVISION ONLY DATED 05/06/21 AS DESCRIBED BELOW.

DocuSigned by:
Michelle Ward 5/6/2021
SIGNATURE DATE

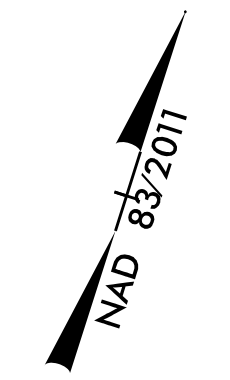

DATE	DESCRIPTION	DWG. BY	DES'D BY	REV'D BY
05/06/21	ADDED LEFT TURN MARKINGS ON -L- FOR THE EXTENDED LEFT TURN LANE ONTO GLEN LAUREL RD.	CCH	CCH	MW

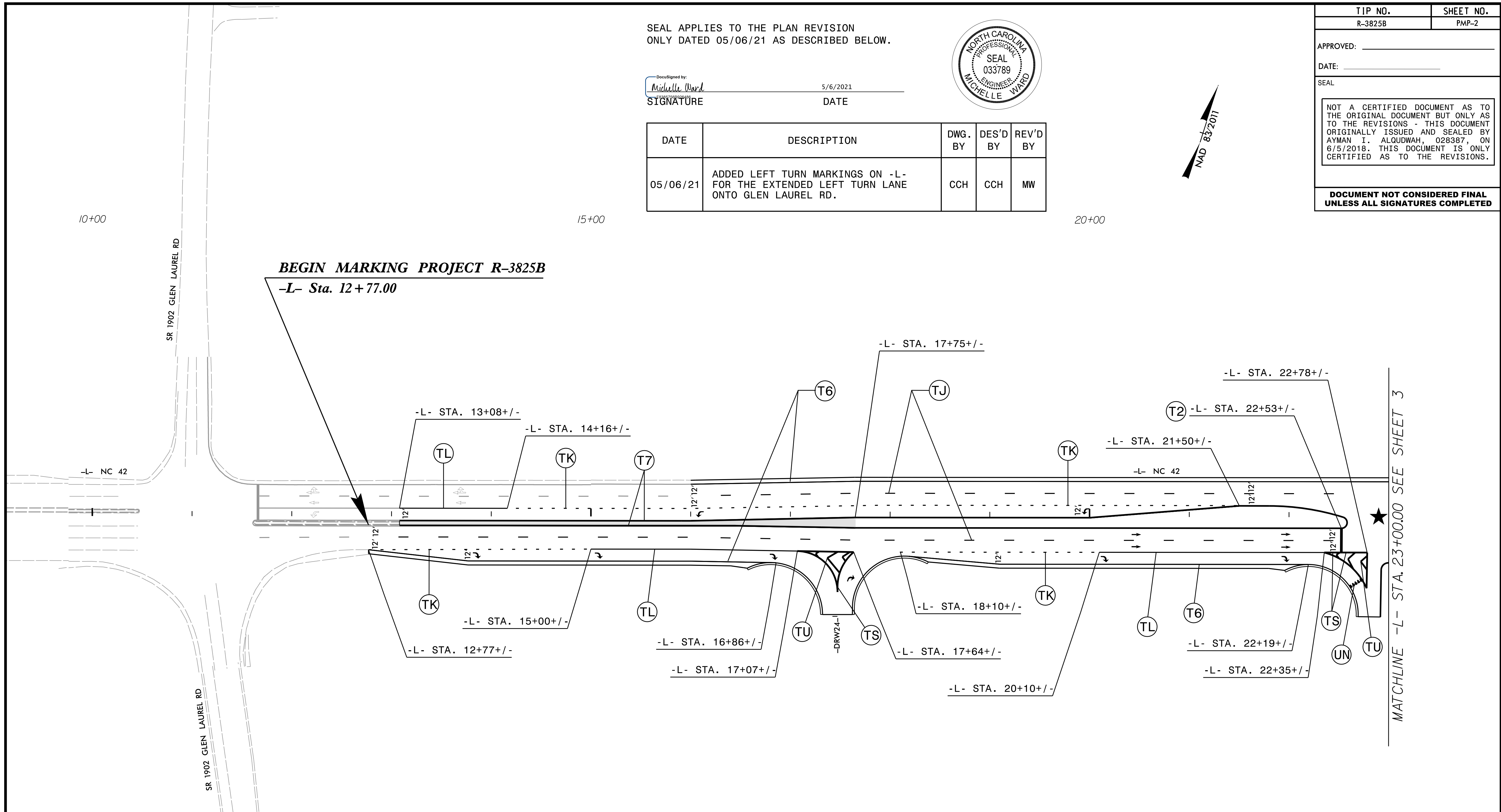

	UA LEFT ARROW		UG COMBO. LEFT/RIGHT/STRAIGHT ARROW
	UB RIGHT ARROW		UI ALPHANUMREIC CHARACTER
	UC STRAIGHT ARROW		UN 24" YIELD LINE TRIANGLE
	UD COMBO. LEFT/STRAIGHT ARROW		UP MERGE ARROW
	UE COMBO. RIGHT/STRAIGHT ARROW		UT U-TURN ARROW
	UF COMBO. LEFT/RIGHT ARROW		

PAVEMENT MARKING DETAIL

5/6/2021
 c:\pwworking\ees\01\d1812251\pmp\psh_a02_REVISED.dgn
 3:05:41 PM

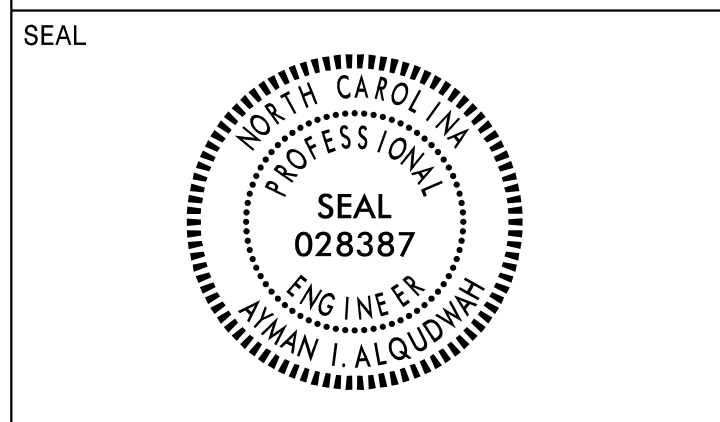

**DOCUMENT NOT CONSIDERED FINAL
 UNLESS ALL SIGNATURES COMPLETED**

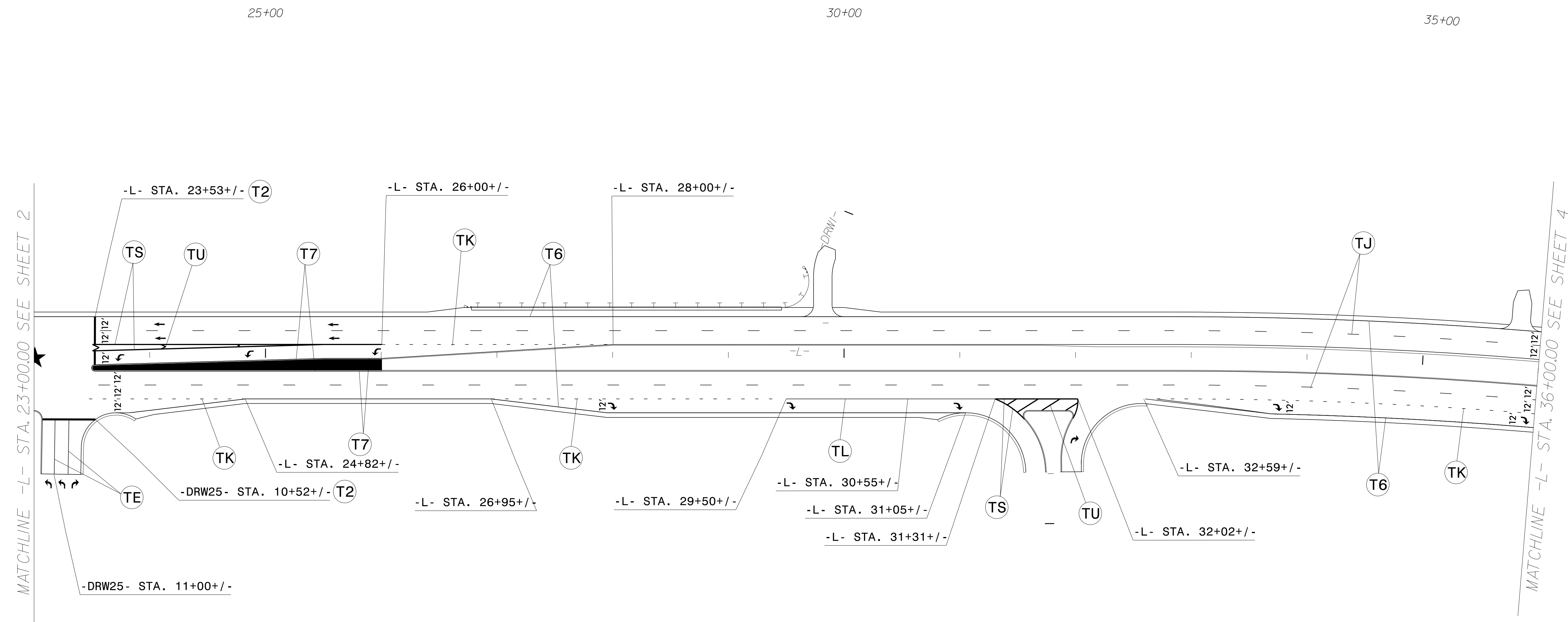
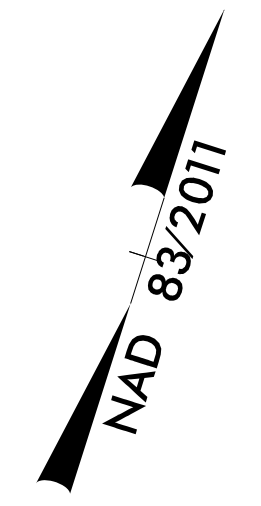

SYMBOL LEGEND	
	UA LEFT ARROW
	UB RIGHT ARROW
	UC STRAIGHT ARROW
	UD COMBO. LEFT/STRAIGHT ARROW
	UE COMBO. RIGHT/STRAIGHT ARROW
	UF COMBO. LEFT/RIGHT ARROW
	UG COMBO. LEFT/RIGHT/STRAIGHT ARROW
	ONLY SCHOOL UI ALPHANUMERIC CHARACTER
	UN 24" YIELD LINE TRIANGLE
	UP MERGE ARROW
	UT U-TURN ARROW

PAVEMENT MARKING DETAIL

06/04/18
 P:\TIP\Projects-R\R3825B\Trafic\Signing\CADD\PM Plan\R-3825b_pmp_psh_s03.dgn
 User:rtward

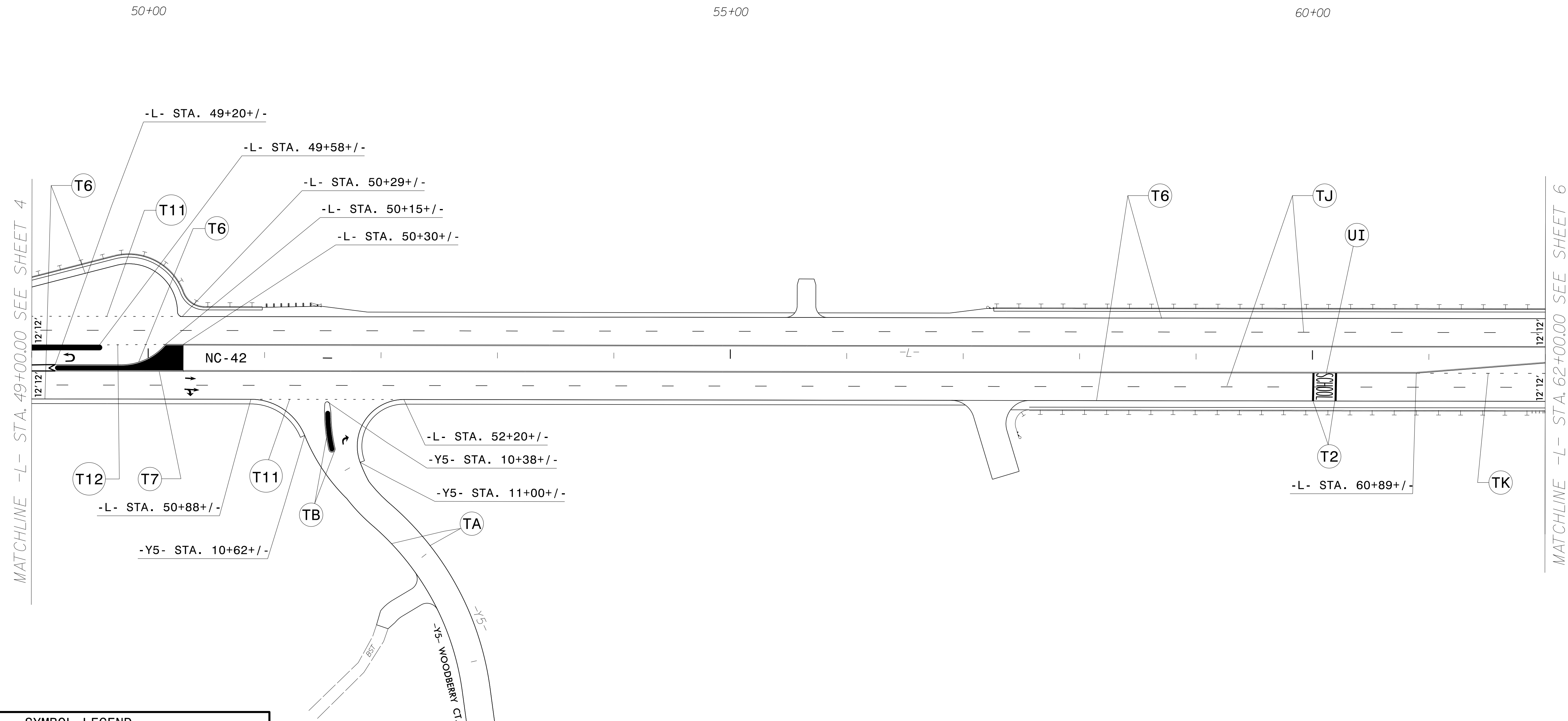

MATCHLINE -L- STA. 49+00.00 SEE SHEET 4

MATCHLINE -L- STA. 62+00.00 SEE SHEET 6

SYMBOL LEGEND	
	UA LEFT ARROW
	UB RIGHT ARROW
	UC STRAIGHT ARROW
	UD COMBO. LEFT/STRAIGHT ARROW
	UE COMBO. RIGHT/STRAIGHT ARROW
	UF COMBO. LEFT/RIGHT ARROW
	UG COMBO. LEFT/RIGHT/STRAIGHT ARROW
	ONLY SCHOOL
	UI ALPHANUMERIC CHARACTER
	UN 24" YIELD LINE TRIANGLE
	UP MERGE ARROW
	UT U-TURN ARROW

END CONSTRUCTION
-Y5- POT Sta. 14+22.00

PAVEMENT MARKING DETAIL

06/04/18
P:\TIP\Projects-R\R3825B\Traffic\Signing\CADD\PM Plan\R-3825b_pmp_psh_s05.dgn
User:rtward

SYMBOL LEGEND					
	UA	LEFT ARROW		UG	COMBO. LEFT/RIGHT/ STRAIGHT ARROW
	UB	RIGHT ARROW		UI	ALPHANUMERIC CHARACTER
	UC	STRAIGHT ARROW		UN	24" YIELD LINE TRIANGLE
	UD	COMBO. LEFT/ STRAIGHT ARROW		UP	MERGE ARROW
	UE	COMBO. RIGHT/ STRAIGHT ARROW		UT	U-TURN ARROW
	UF	COMBO. LEFT/ RIGHT ARROW			

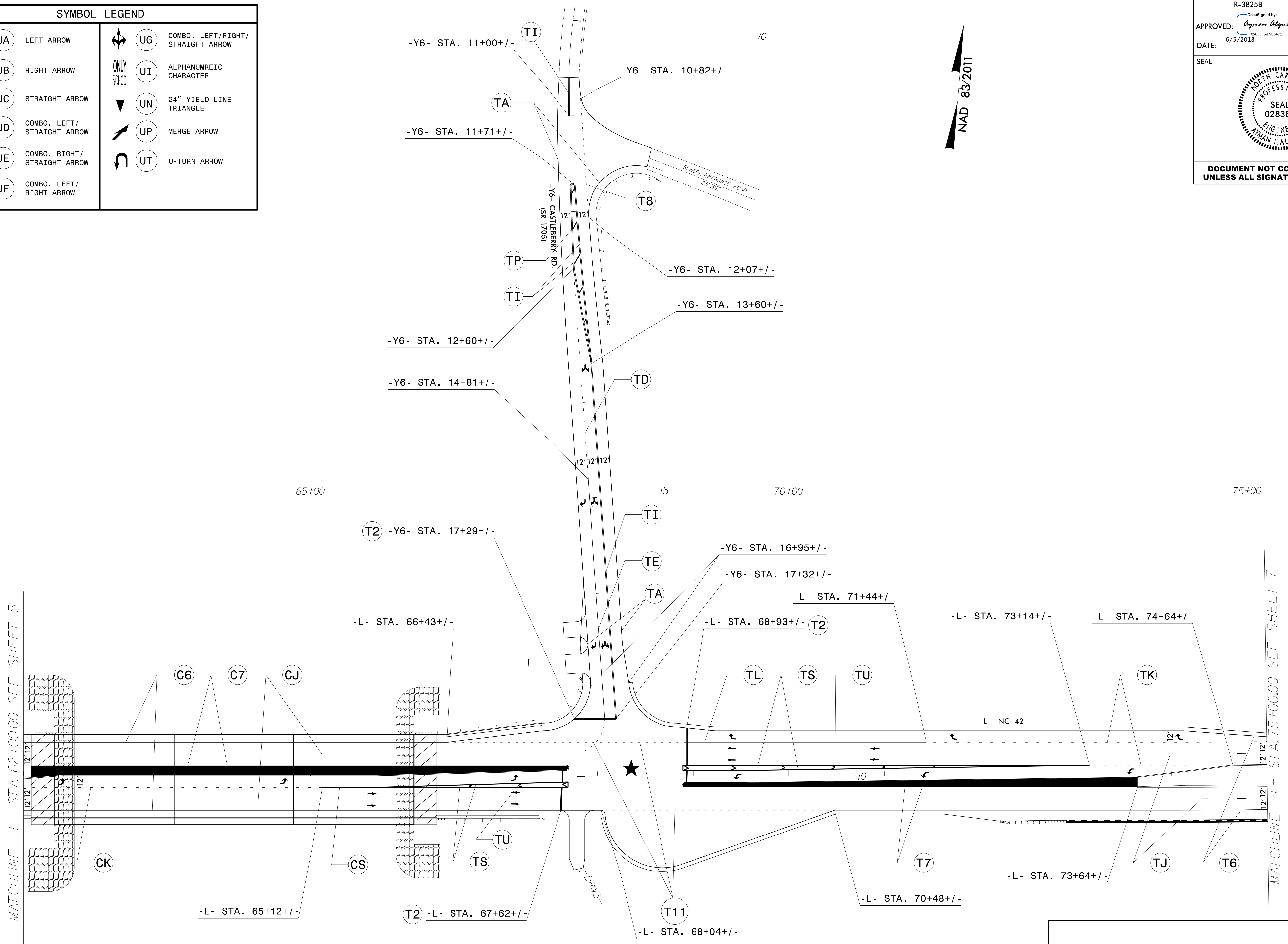

06/04/18
 P:\TIP\Projects-R\3825B\Traffic\Signing\CADD\PMI Plan\3825b_pmp_psh_s06.dgn
 User:rtward

PAVEMENT MARKING DETAIL

SYMBOL LEGEND					
	UA	LEFT ARROW		UG	COMBO. LEFT/RIGHT/ STRAIGHT ARROW
	UB	RIGHT ARROW		UI	ALPHANUMERIC CHARACTER
	UC	STRAIGHT ARROW		UN	24" YIELD LINE TRIANGLE
	UD	COMBO. LEFT/ STRAIGHT ARROW		UP	MERGE ARROW
	UE	COMBO. RIGHT/ STRAIGHT ARROW		UT	U-TURN ARROW
	UF	COMBO. LEFT/ RIGHT ARROW			

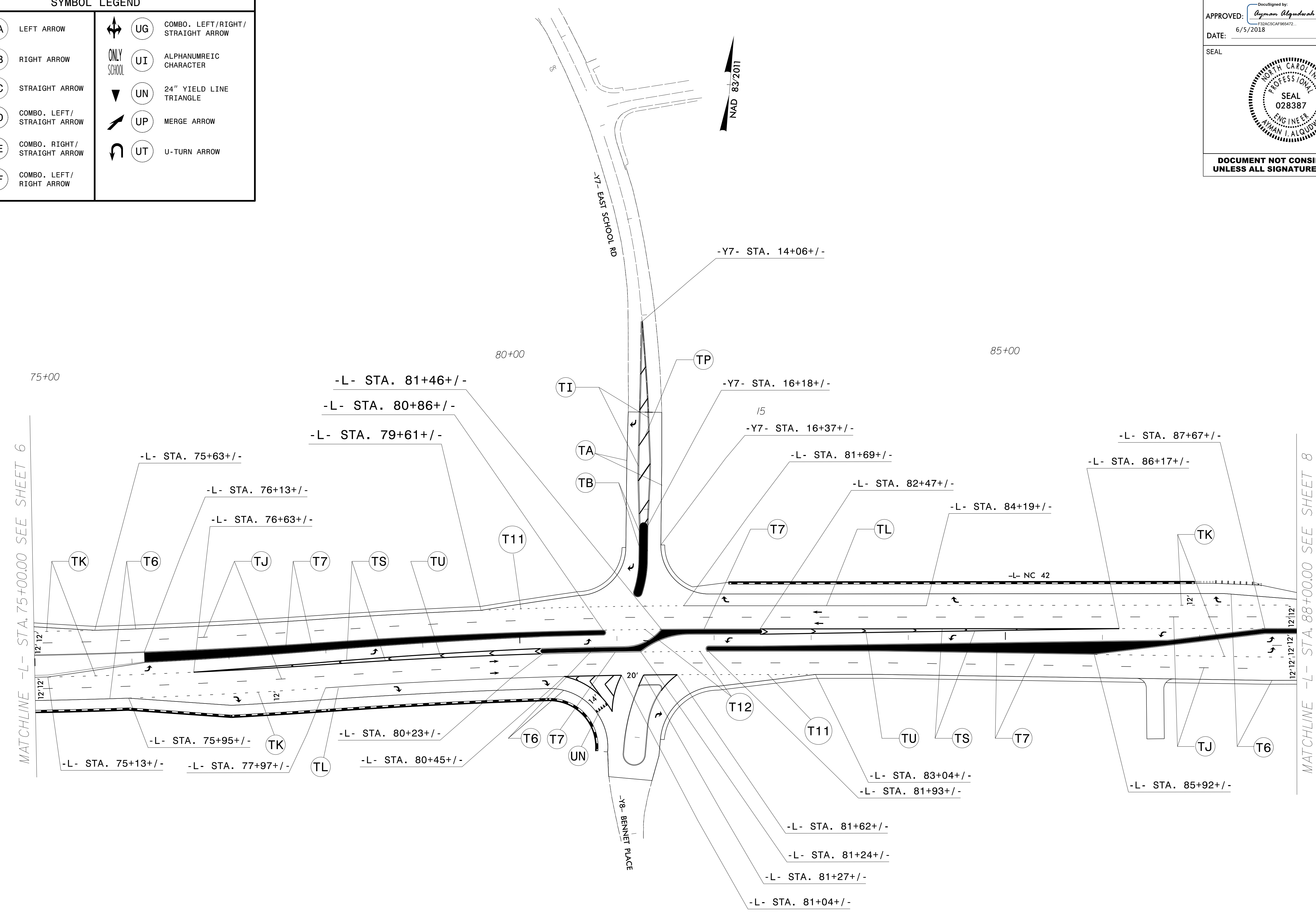

06/04/18
 P:\TIP\Projects-R\R3825B\Traffic\Signing\CADD\PM Plan\R-3825b_pmp_psh_s07.dgn
 User:rtward

PAVEMENT MARKING DETAIL

APPROVED: *Osman Alqudwah*
DocuSigned by:
 F32AC5CAF965472
 DATE: 6/5/2018

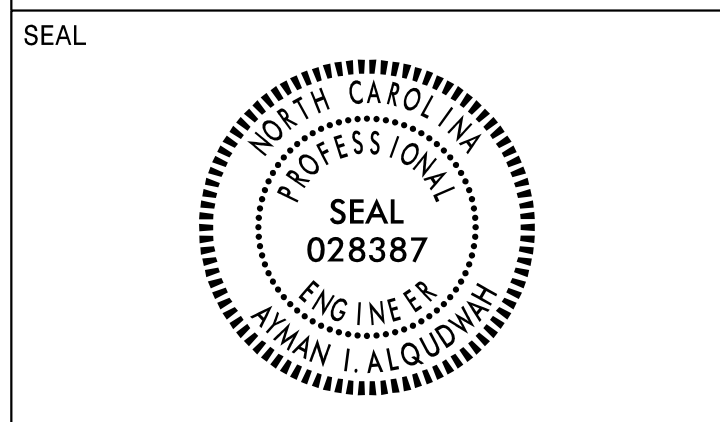

DOCUMENT NOT CONSIDERED FINAL
 UNLESS ALL SIGNATURES COMPLETED

SYMBOL LEGEND					
	UA	LEFT ARROW		UG	COMBO. LEFT/RIGHT/ STRAIGHT ARROW
	UB	RIGHT ARROW		UI	ALPHANUMREIC CHARACTER
	UC	STRAIGHT ARROW		UN	24" YIELD LINE TRIANGLE
	UD	COMBO. LEFT/ STRAIGHT ARROW		UP	MERGE ARROW
	UE	COMBO. RIGHT/ STRAIGHT ARROW		UT	U-TURN ARROW
	UF	COMBO. LEFT/ RIGHT ARROW			

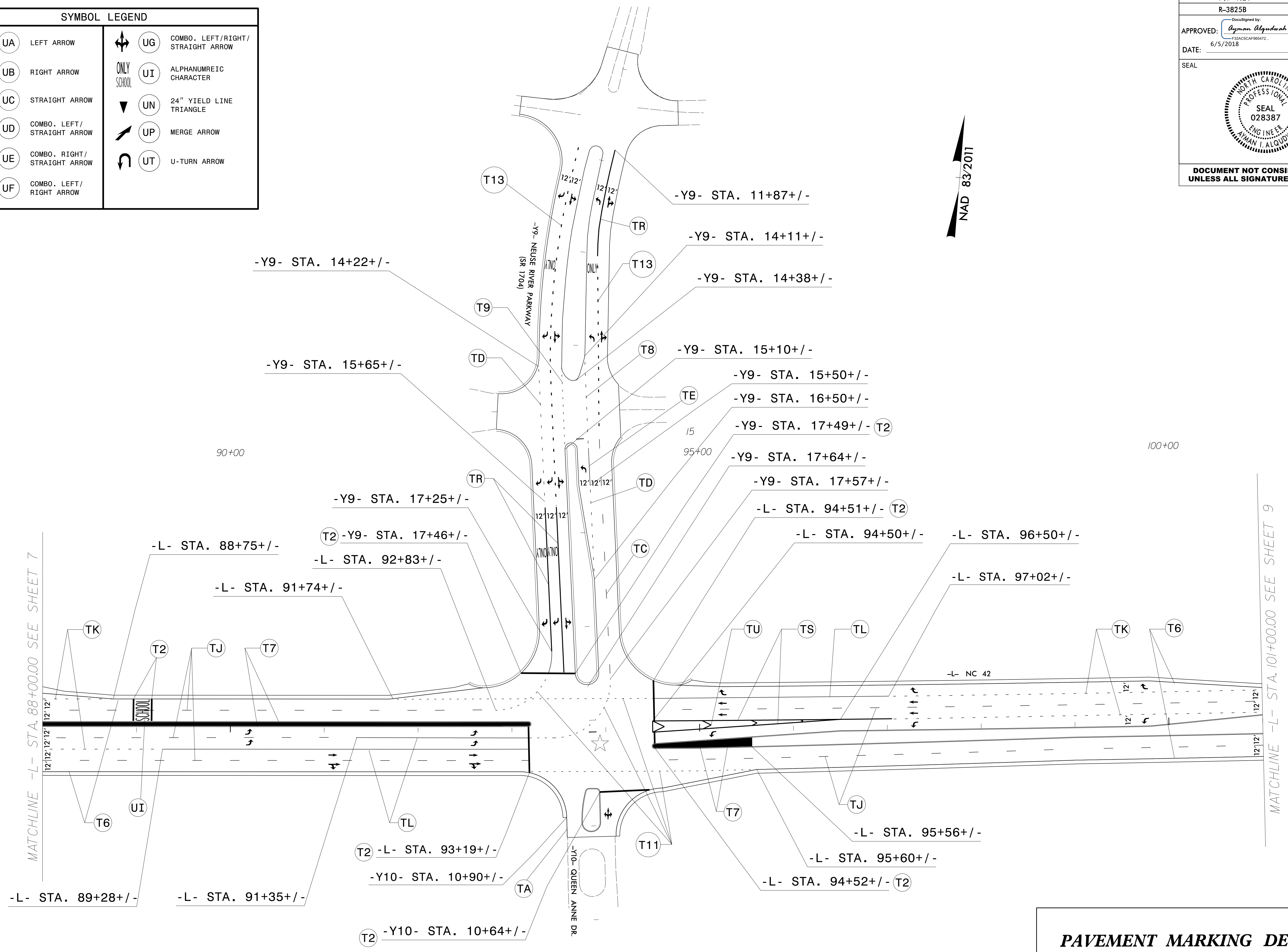

06/05/18
 P:\TIP\Projects-R\3825B\Traffic\Signing\CADD\PM\Plan\3825b_pmp_psh_s08.dgn
 User:rtward

PAVEMENT MARKING DETAIL

APPROVED: *Osman Alqudwah*
DocuSigned by:
 Osman Alqudwah
 F32AC5CAF985472...
 DATE: 6/5/2018

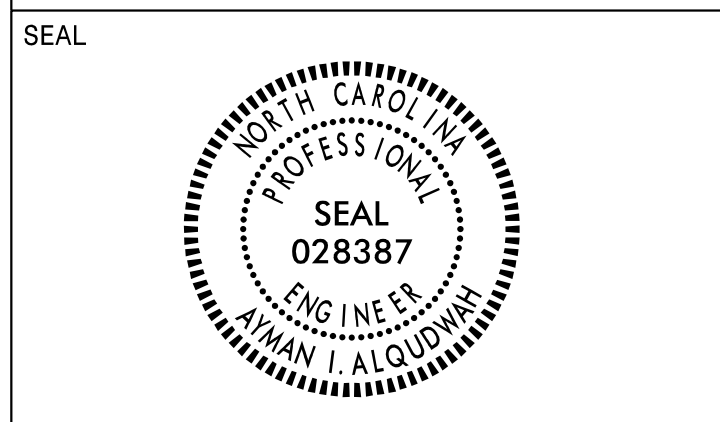

**DOCUMENT NOT CONSIDERED FINAL
 UNLESS ALL SIGNATURES COMPLETED**

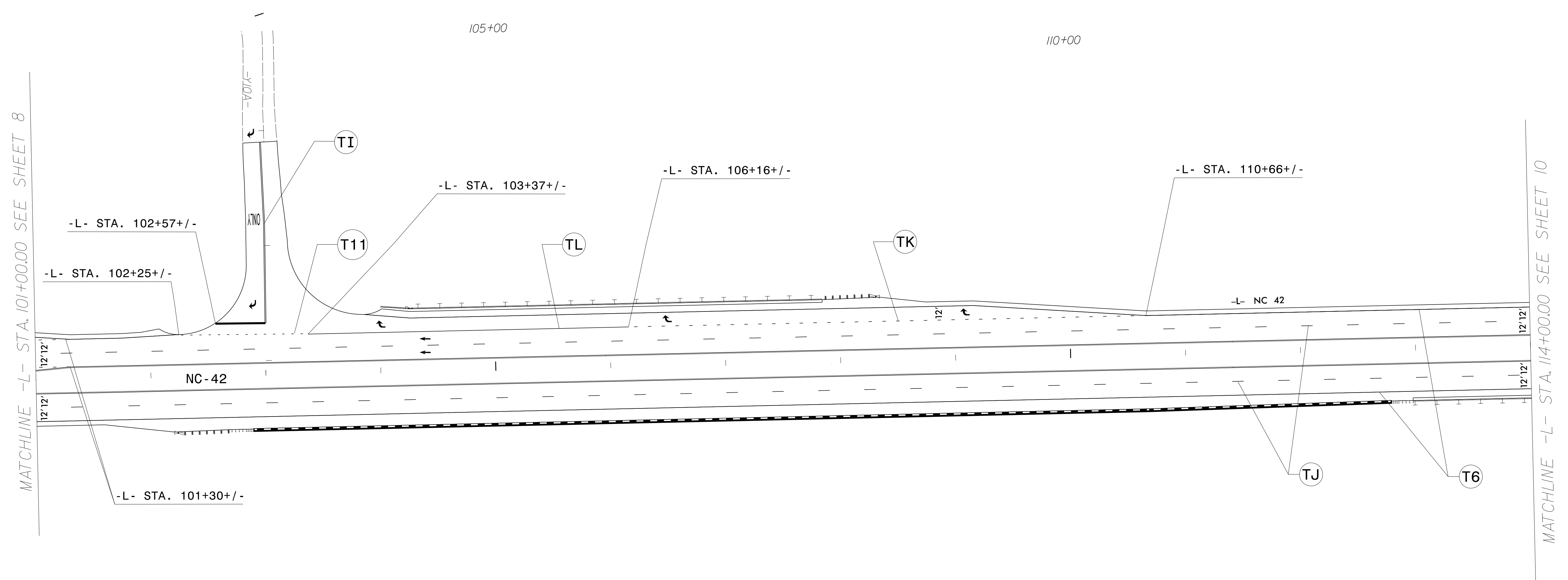
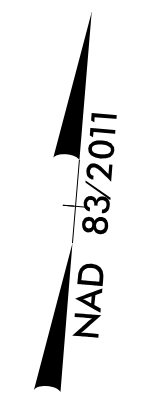

SYMBOL LEGEND	
	UA LEFT ARROW
	UB RIGHT ARROW
	UC STRAIGHT ARROW
	UD COMBO. LEFT/STRAIGHT ARROW
	UE COMBO. RIGHT/STRAIGHT ARROW
	UF COMBO. LEFT/RIGHT ARROW
	UG COMBO. LEFT/RIGHT/STRAIGHT ARROW
	ONLY SCHOOL UI ALPHANUMREIC CHARACTER
	UN 24" YIELD LINE TRIANGLE
	UP MERGE ARROW
	UT U-TURN ARROW

PAVEMENT MARKING DETAIL

06/04/18
 P:\TIP\Projects-R\3825B\Traffic\Signing\CADD\PM Plan\3825b_pmp_psh_s09.dgn
 User:rtward

APPROVED: *Osman Alqudwah*
DocuSigned by:
 Osman Alqudwah
 F32AC5CAF985472...
 DATE: 6/5/2018



**DOCUMENT NOT CONSIDERED FINAL
 UNLESS ALL SIGNATURES COMPLETED**

SYMBOL LEGEND			
UA	LEFT ARROW	UG	COMBO. LEFT/RIGHT/ STRAIGHT ARROW
UB	RIGHT ARROW	UI	ALPHANUMERIC CHARACTER
UC	STRAIGHT ARROW	UN	24" YIELD LINE TRIANGLE
UD	COMBO. LEFT/ STRAIGHT ARROW	UP	MERGE ARROW
UE	COMBO. RIGHT/ STRAIGHT ARROW	UT	U-TURN ARROW
UF	COMBO. LEFT/ RIGHT ARROW		

NAD 83/2011

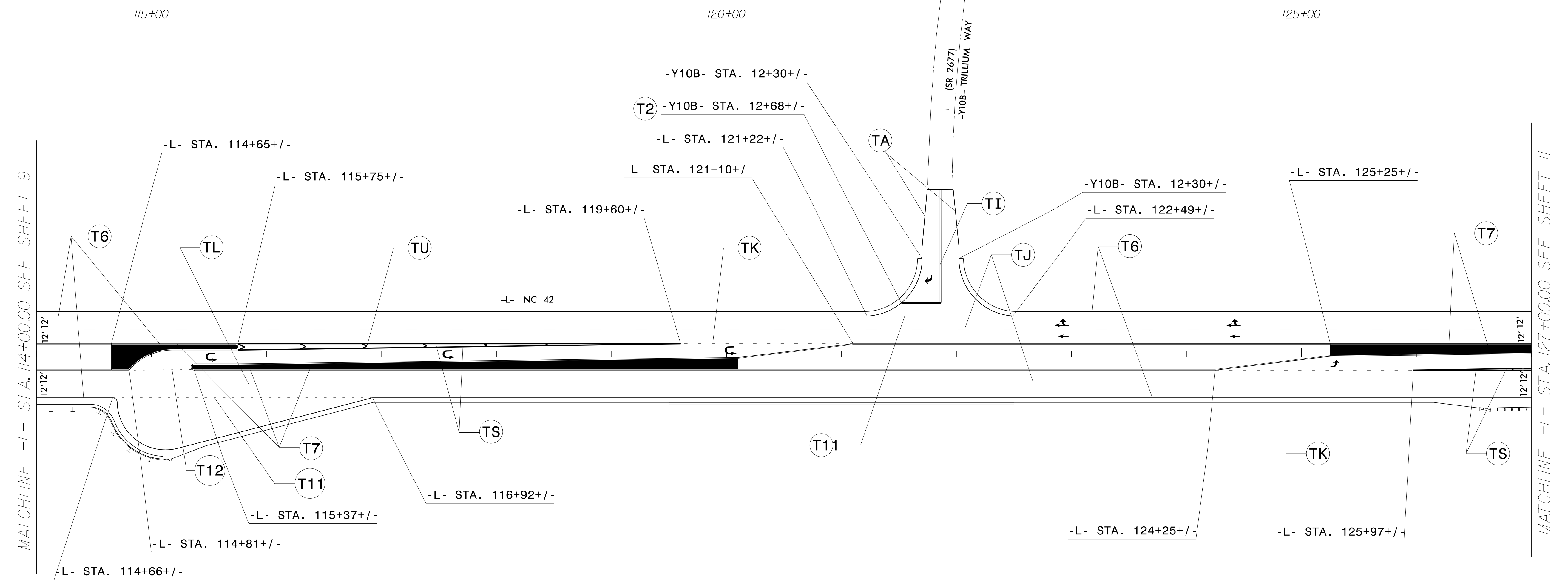

06/04/18
 P:\TIP\Projects-R\R3825B\Traffic\Signing\CADD\PM Plan\R-3825b_pmp_psh_s10.dgn
 User:rtward

PAVEMENT MARKING DETAIL

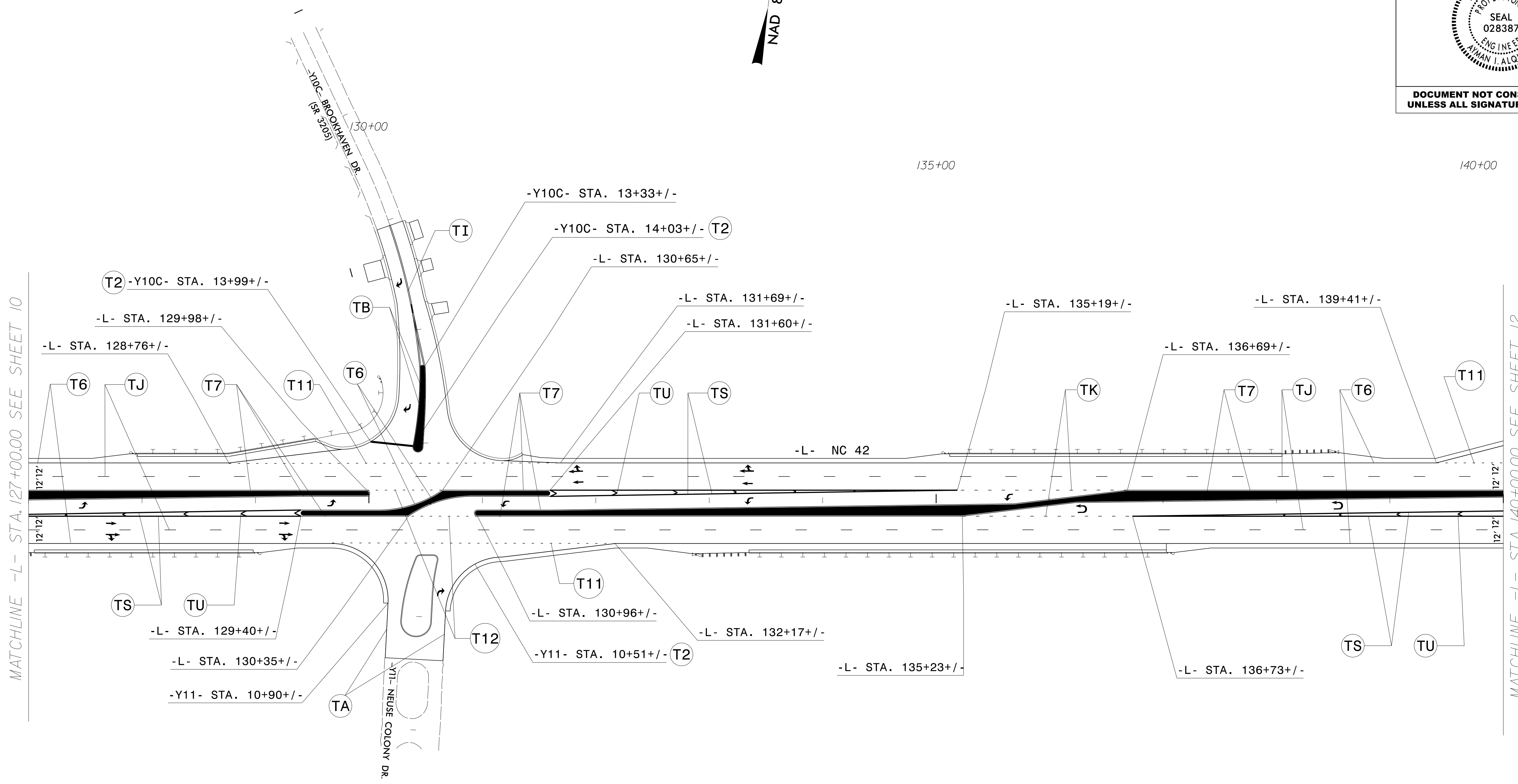
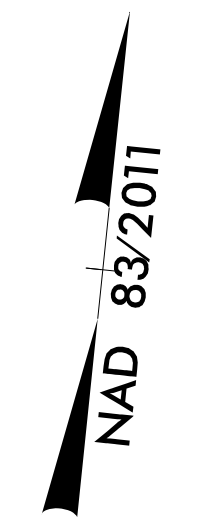

SYMBOL LEGEND					
	UA	LEFT ARROW		UG	COMBO. LEFT/RIGHT/ STRAIGHT ARROW
	UB	RIGHT ARROW		UI	ALPHANUMERIC CHARACTER
	UC	STRAIGHT ARROW		UN	24" YIELD LINE TRIANGLE
	UD	COMBO. LEFT/ STRAIGHT ARROW		UP	MERGE ARROW
	UE	COMBO. RIGHT/ STRAIGHT ARROW		UT	U-TURN ARROW
	UF	COMBO. LEFT/ RIGHT ARROW			

PAVEMENT MARKING DETAIL

06/04/18
 P:\TIP\Projects-R\R3825B\Traffic\Signing\CADD\PM Plan\R-3825b_pmp_psh_s11.dgn
 User:rtward

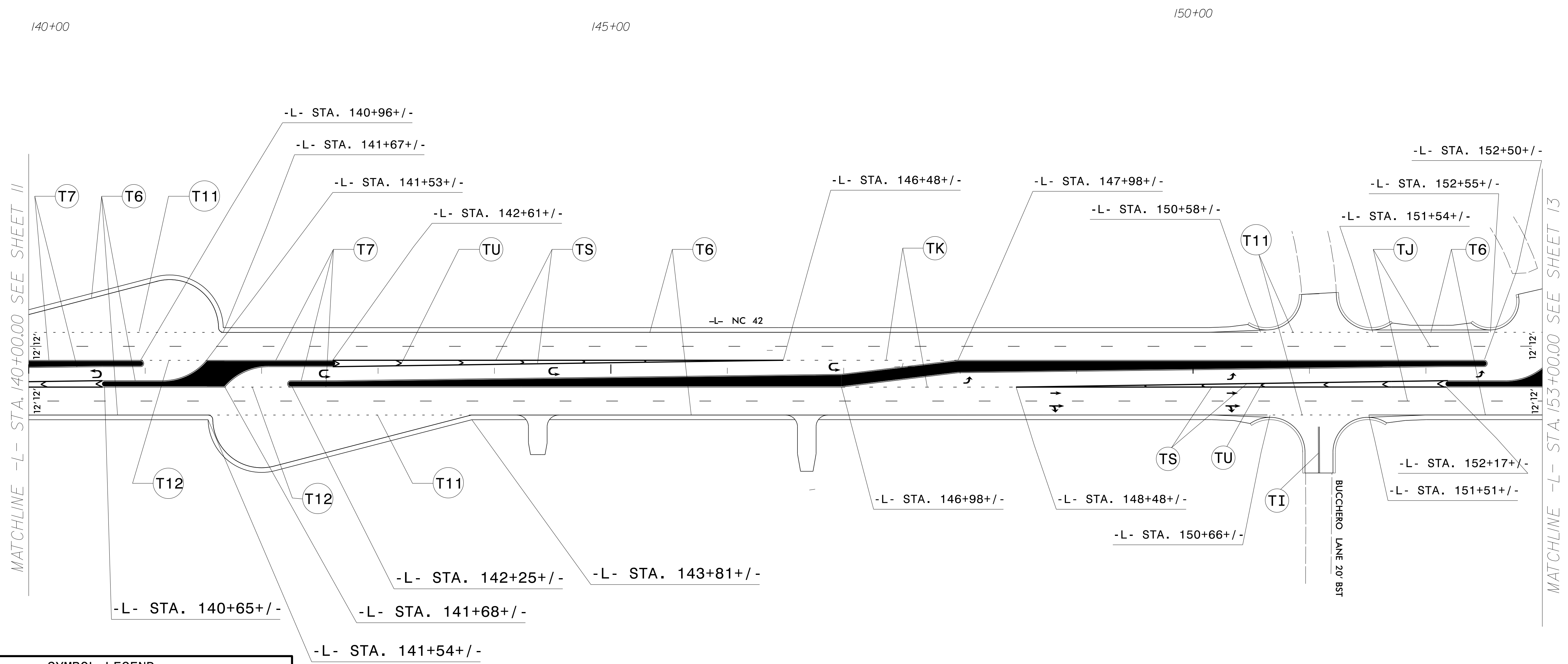
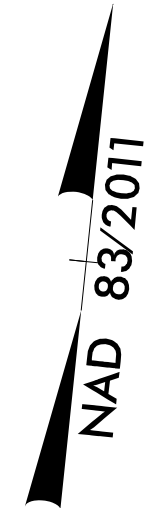

SYMBOL LEGEND					
	UA	LEFT ARROW		UG	COMBO. LEFT/RIGHT/ STRAIGHT ARROW
	UB	RIGHT ARROW		UI	ALPHANUMERIC CHARACTER
	UC	STRAIGHT ARROW		UN	24" YIELD LINE TRIANGLE
	UD	COMBO. LEFT/ STRAIGHT ARROW		UP	MERGE ARROW
	UE	COMBO. RIGHT/ STRAIGHT ARROW		UT	U-TURN ARROW
	UF	COMBO. LEFT/ RIGHT ARROW			

PAVEMENT MARKING DETAIL

06/04/18
 P:\TIP\Projects-R\R3825B\Traffic\Signing\CADD\PM Plan\R-3825b_pmp_psh_sl2.dgn
 User:rtward

TIP NO. R-3825B	SHEET NO. PMP-13
APPROVED: <i>Rayman Alquodwah</i> F32ACSCAP985472... DATE: 6/5/2018	
SEAL 	
DOCUMENT NOT CONSIDERED FINAL UNLESS ALL SIGNATURES COMPLETED	

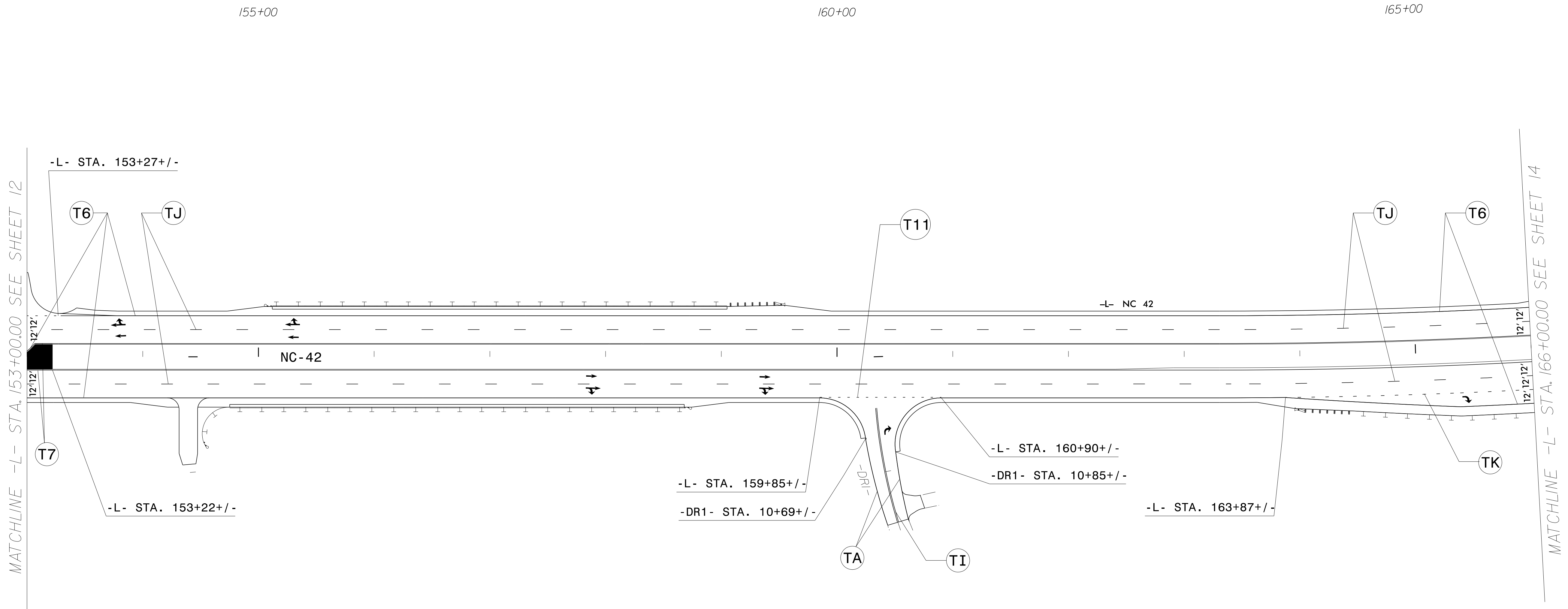

SYMBOL LEGEND			
	UA LEFT ARROW		UG COMBO. LEFT/RIGHT/STRAIGHT ARROW
	UB RIGHT ARROW		UI ALPHANUMREIC CHARACTER
	UC STRAIGHT ARROW		UN 24" YIELD LINE TRIANGLE
	UD COMBO. LEFT/STRAIGHT ARROW		UP MERGE ARROW
	UE COMBO. RIGHT/STRAIGHT ARROW		UT U-TURN ARROW
	UF COMBO. LEFT/RIGHT ARROW		

PAVEMENT MARKING DETAIL

06/04/18
 P:\TIP\Projects-R\R3825B\Traffic\Signing\CADD\PM Plan\R-3825b_pmp_psh_s13.dgn
 User:rtward

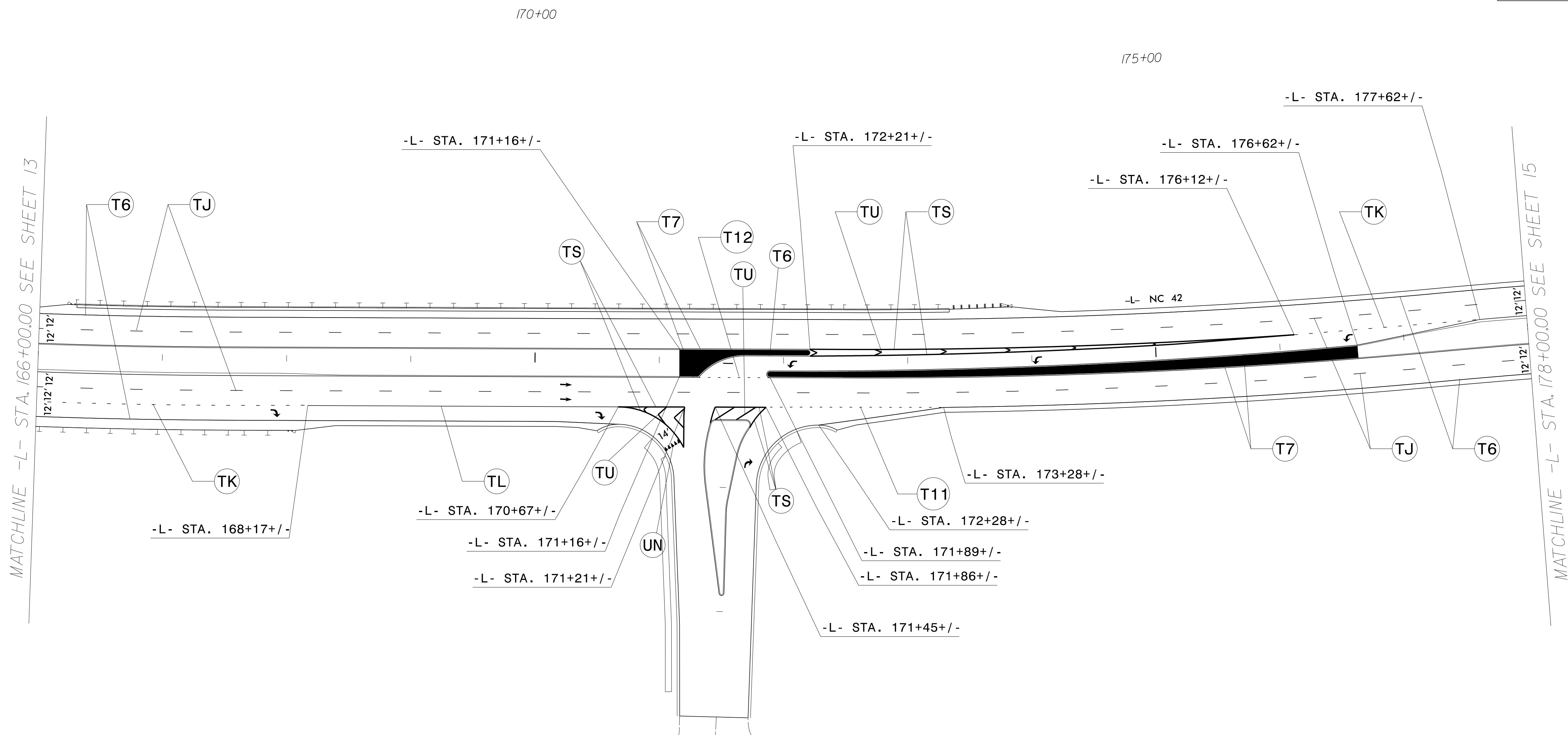
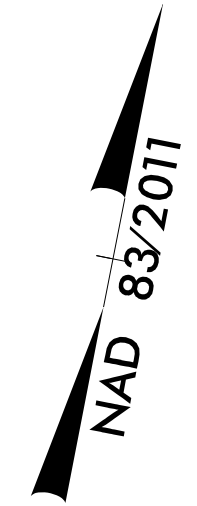

SYMBOL LEGEND			
	UA LEFT ARROW		UG COMBO. LEFT/RIGHT/STRAIGHT ARROW
	UB RIGHT ARROW		UI ALPHANUMERIC CHARACTER
	UC STRAIGHT ARROW		UN 24" YIELD LINE TRIANGLE
	UD COMBO. LEFT/STRAIGHT ARROW		UP MERGE ARROW
	UE COMBO. RIGHT/STRAIGHT ARROW		UT U-TURN ARROW
	UF COMBO. LEFT/RIGHT ARROW		

PAVEMENT MARKING DETAIL

06/04/18
 P:\TIP\Projects-R\3825B\Traffic\Signing\CADD\PM Plan\3825b_pmp_psh_s14.dgn
 User:rtward

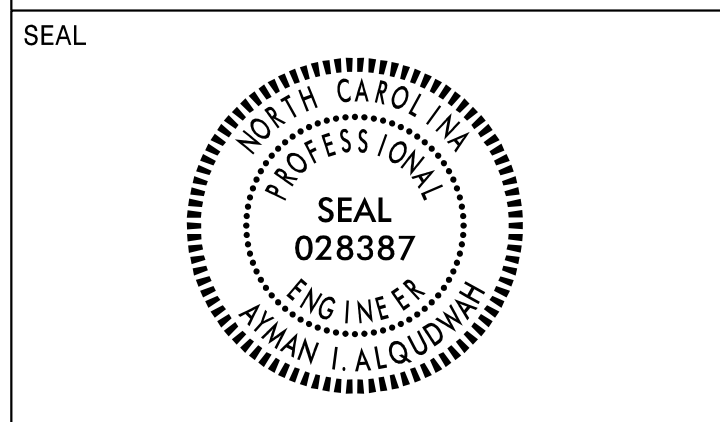

**DOCUMENT NOT CONSIDERED FINAL
 UNLESS ALL SIGNATURES COMPLETED**

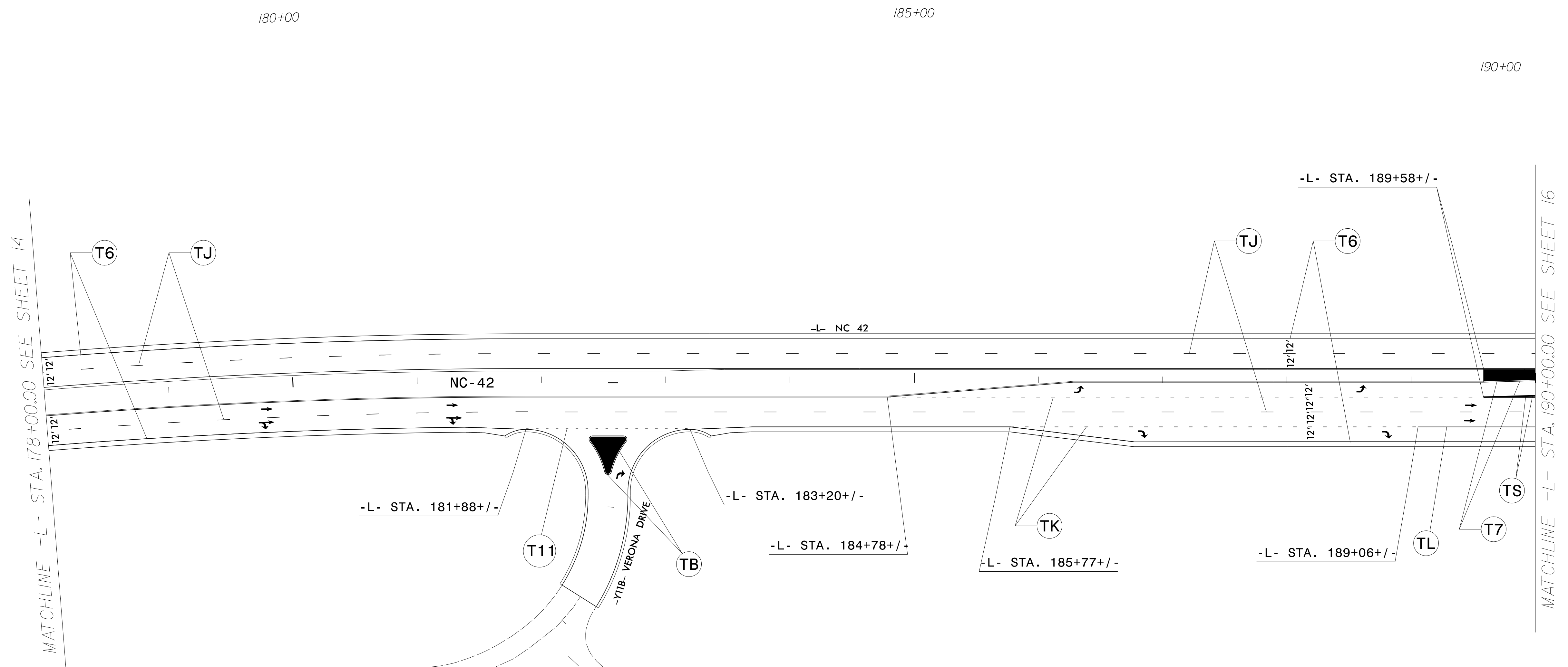

SYMBOL LEGEND			
UA	LEFT ARROW	UG	COMBO. LEFT/RIGHT/ STRAIGHT ARROW
UB	RIGHT ARROW	UI	ALPHANUMERIC CHARACTER
UC	STRAIGHT ARROW	UN	24" YIELD LINE TRIANGLE
UD	COMBO. LEFT/ STRAIGHT ARROW	UP	MERGE ARROW
UE	COMBO. RIGHT/ STRAIGHT ARROW	UT	U-TURN ARROW
UF	COMBO. LEFT/ RIGHT ARROW		

PAVEMENT MARKING DETAIL

06/04/18
 P:\TIP\Projects-R\3825B\Traffic\Signing\CADD\PM Plan\3825b_pmp_psh_sl5.dgn
 User:rlward



DOCUMENT NOT CONSIDERED FINAL UNLESS ALL SIGNATURES COMPLETED

01/07/20
ADDED RIGHT TURN LANE TO
-Y11C- AND UPDATED MARKINGS
D. BEARD

02/18/20
CHANGED ALIGNMENT OF -Y12-
AND -Y11C-
D. BEARD

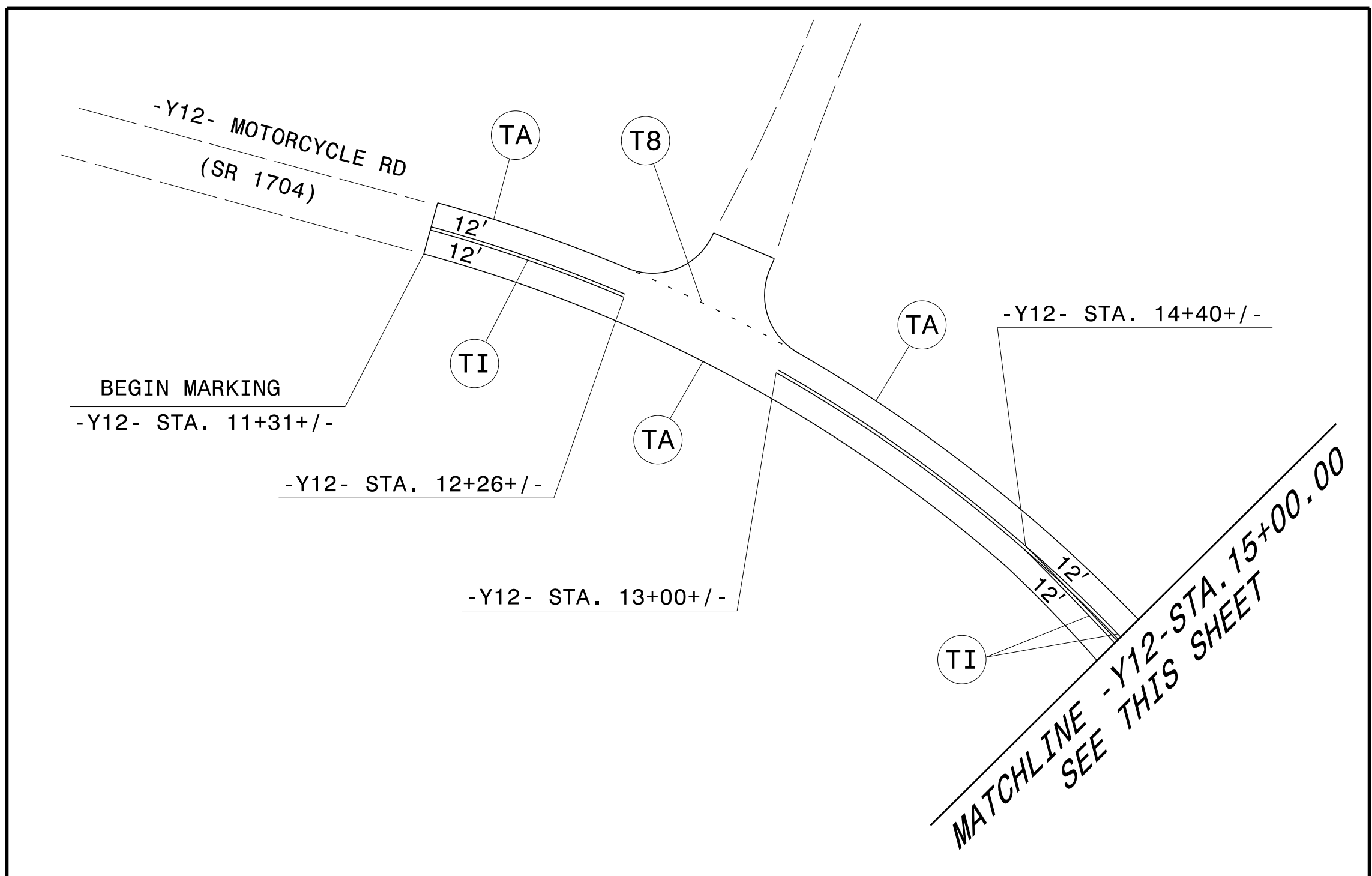
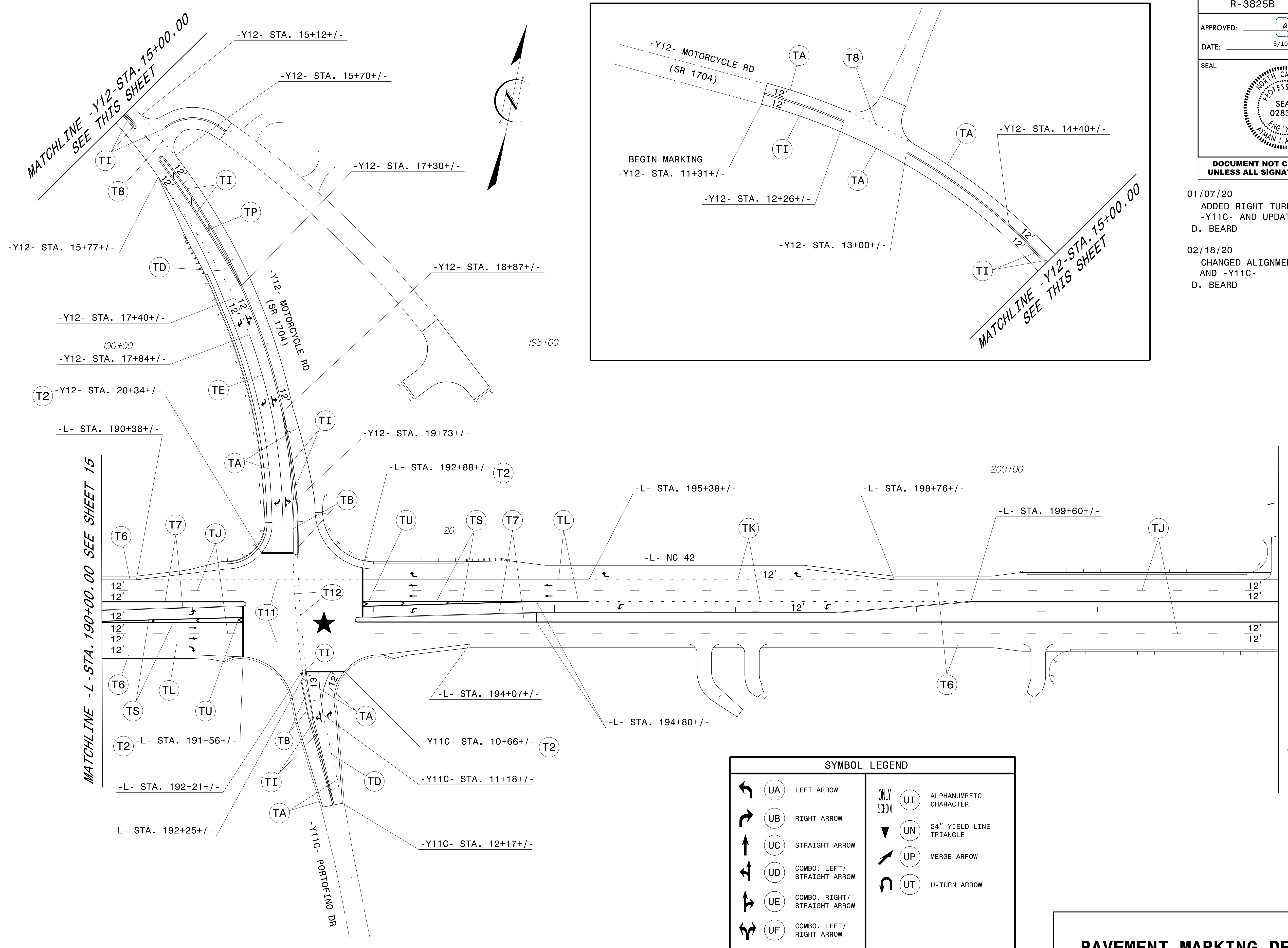

SYMBOL LEGEND	
	UA LEFT ARROW
	UB RIGHT ARROW
	UC STRAIGHT ARROW
	UD COMBO. LEFT/STRAIGHT ARROW
	UE COMBO. RIGHT/STRAIGHT ARROW
	UF COMBO. LEFT/RIGHT ARROW
	ONLY SCHOOL UI ALPHANUMERIC CHARACTER
	UN 24" YIELD LINE TRIANGLE
	UP MERGE ARROW
	UT U-TURN ARROW

PAVEMENT MARKING DETAIL

03/09/20
 P:\TIPR\Projects-R\3825B\Traffic\Signing\CADD\PM Plan\3825b_pmp_psh_s16_REVISED-2.dgn
 User:dhbeard

MATCHLINE -L- STA. 190+00.00 SEE SHEET 15

MATCHLINE -L- STA. 203+00.00 SEE SHEET 17

TIP NO. R-3825B	SHEET NO. PMP-17
APPROVED: <i>Uyman Alquodwah</i> <small>F32ACSCAP985472...</small> DATE: 6/5/2018	
SEAL 	
DOCUMENT NOT CONSIDERED FINAL UNLESS ALL SIGNATURES COMPLETED	

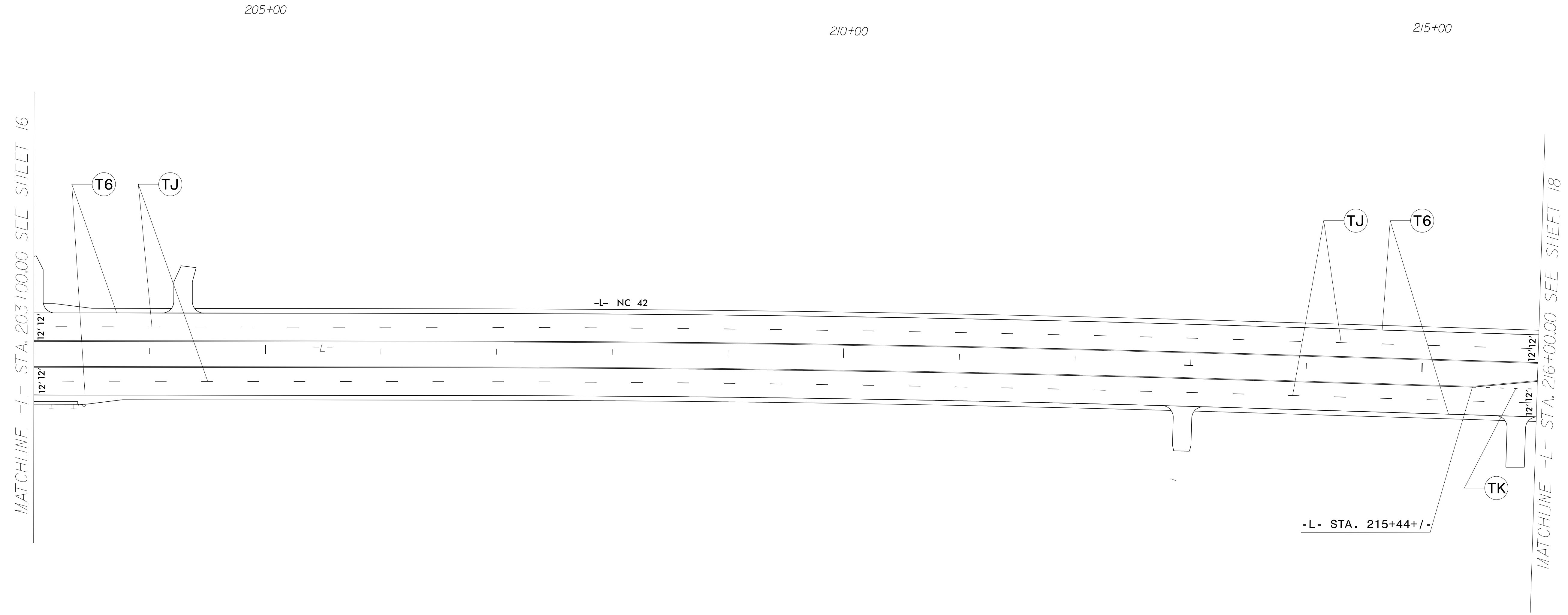
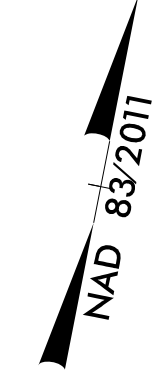

SYMBOL LEGEND			
UA	LEFT ARROW	UG	COMBO. LEFT/RIGHT/ STRAIGHT ARROW
UB	RIGHT ARROW	ONLY SCHOOL	ALPHANUMREIC CHARACTER
UC	STRAIGHT ARROW	UN	24" YIELD LINE TRIANGLE
UD	COMBO. LEFT/ STRAIGHT ARROW	UP	MERGE ARROW
UE	COMBO. RIGHT/ STRAIGHT ARROW	UT	U-TURN ARROW
UF	COMBO. LEFT/ RIGHT ARROW		

PAVEMENT MARKING DETAIL

06/04/18
 P:\TIP\Projects-R\3825B\Traffic\Signing\CADD\PM Plan\3825b_pmp_psh_sl7.dgn
 User:rlward

SYMBOL LEGEND					
	UA	LEFT ARROW		UG	COMBO. LEFT/RIGHT/STRAIGHT ARROW
	UB	RIGHT ARROW		UI	ALPHANUMERIC CHARACTER
	UC	STRAIGHT ARROW		UN	24" YIELD LINE TRIANGLE
	UD	COMBO. LEFT/STRAIGHT ARROW		UP	MERGE ARROW
	UE	COMBO. RIGHT/STRAIGHT ARROW		UT	U-TURN ARROW
	UF	COMBO. LEFT/RIGHT ARROW			

**DUE TO THE COMPLEX NATURE OF SIDEWALKS AND STREETSCAPE PLANS THE CURB RAMP ARE SHOWN AS A GUIDE. REFER TO THE STREETSCAPE AND ALTERNATE CURB RAMP DESIGNS IN THE ROADWAY PLANS.

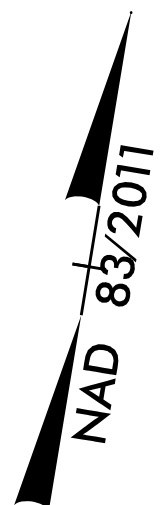

SEAL APPLIES TO THE PLAN REVISION ONLY DATED 11/17/20 AS DESCRIBED BELOW.



DocuSigned by:
Michelle Ward 1/8/2021
SIGNATURE DATE

DATE	DESCRIPTION	DWG. BY	DES'D BY	REV'D BY
01/08/21	ADDED DUAL LEFT TURN MARKINGS ON -DRW27-. REVISED STOP BARS AND CROSSWALKS ON -L- AND -Y12A- DUE TO DESIGN REVISIONS. CURB RAMP REVISED IN ALL FOUR QUADRANTS OF THE INTERSECTION. REVISED MARKINGS AND CURB RAMP DUE TO DESIGN CHANGE OF TURN OUT AT -L- 228+25+/-.	CCH	CCH	MW

NOT A CERTIFIED DOCUMENT AS TO THE ORIGINAL DOCUMENT BUT ONLY AS TO THE REVISIONS - THIS DOCUMENT ORIGINALLY ISSUED AND SEALED BY AYMAN I. ALQUDWAH, 028387, ON 6/5/2018. THIS DOCUMENT IS ONLY CERTIFIED AS TO THE REVISIONS.

DOCUMENT NOT CONSIDERED FINAL UNLESS ALL SIGNATURES COMPLETED

10/15/19 - ADDED MARKINGS FOR RIGHT TURN LANE AT -L- STA. 224+35+/-
D. BEARD

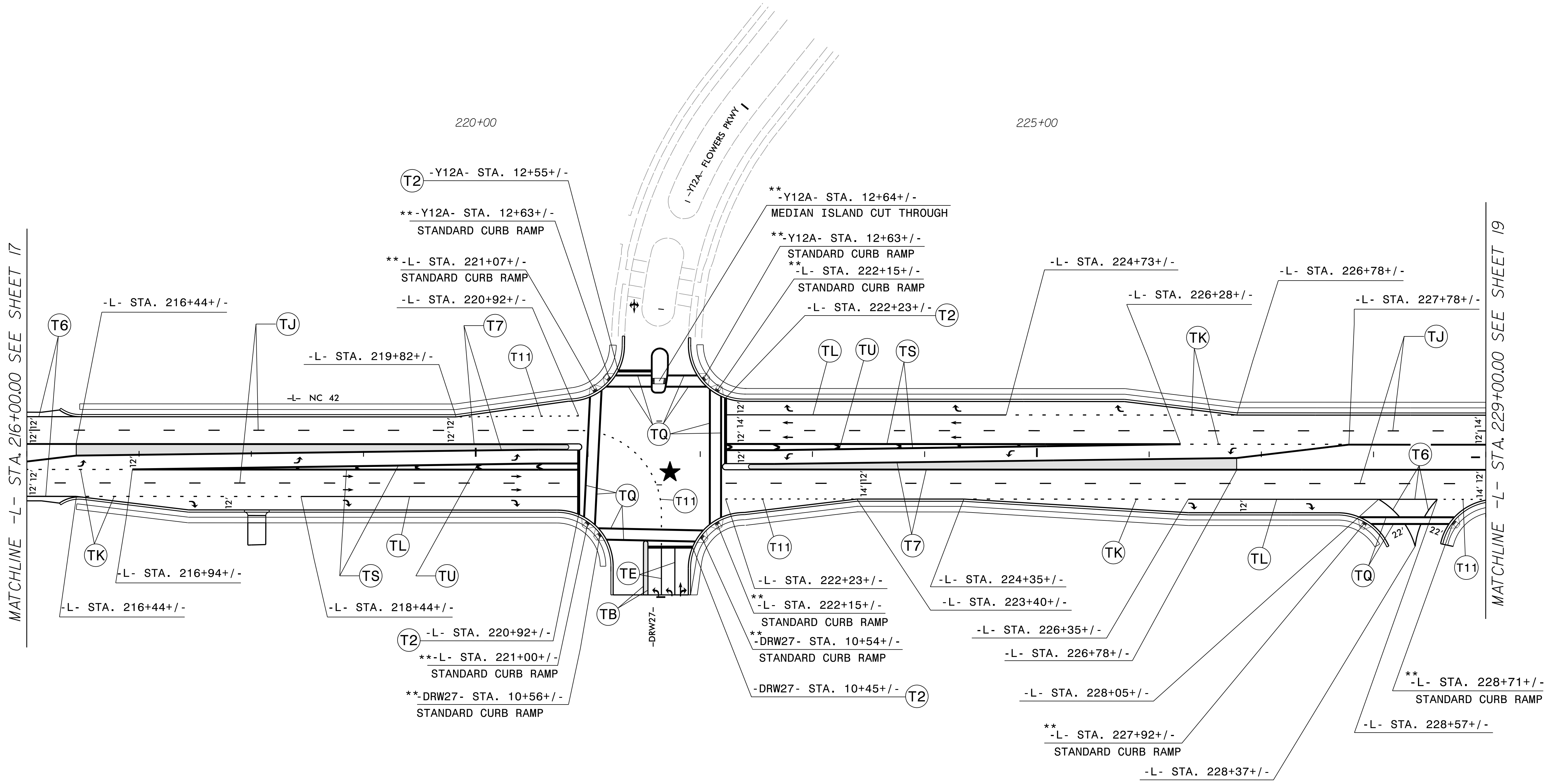

MATCHLINE -L- STA. 216+00.00 SEE SHEET 17

MATCHLINE -L- STA. 229+00.00 SEE SHEET 19

1/8/2021
c:\pwworking\king\east01\dl1812251\3825b_pmp_psh_sl18_REVISED-2.dgn
5:18:47 AM

PAVEMENT MARKING DETAIL

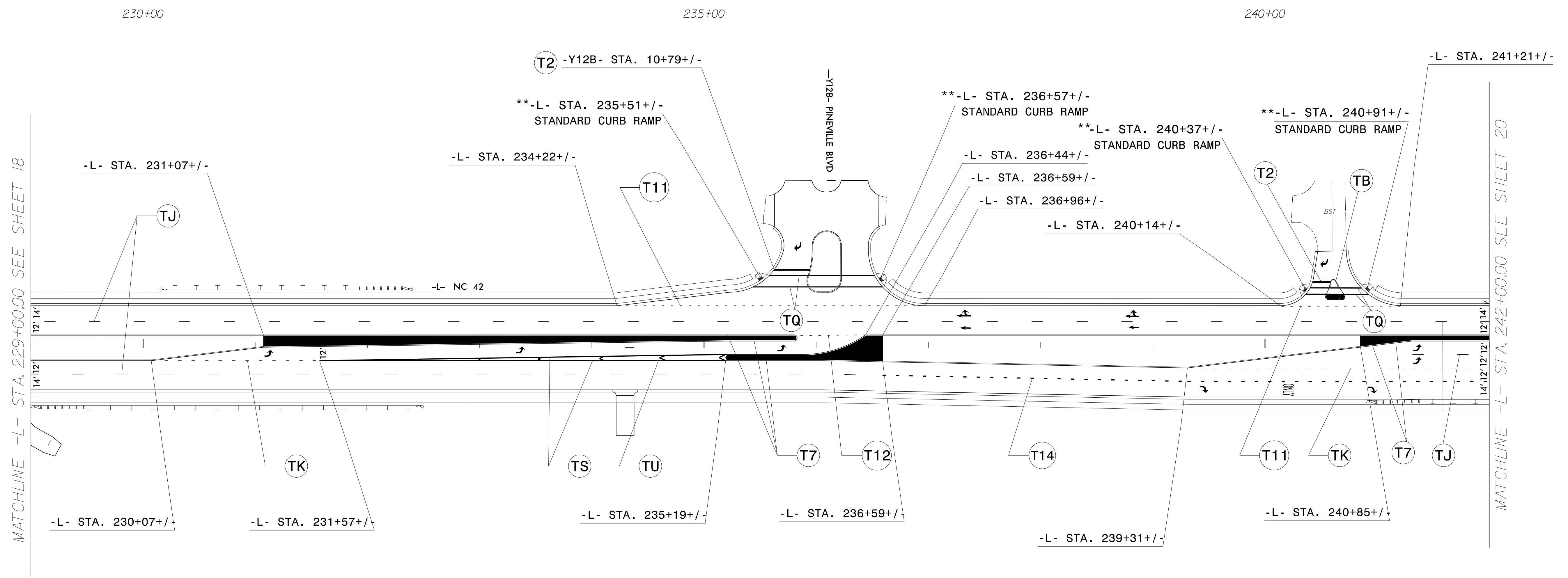

MATCHLINE -L- STA. 229+00.00 SEE SHEET 18

MATCHLINE -L- STA. 242+00.00 SEE SHEET 20

SYMBOL LEGEND					
	UA	LEFT ARROW		UG	COMBO. LEFT/RIGHT/ STRAIGHT ARROW
	UB	RIGHT ARROW		UI	ALPHANUMREIC CHARACTER
	UC	STRAIGHT ARROW		UN	24" YIELD LINE TRIANGLE
	UD	COMBO. LEFT/ STRAIGHT ARROW		UP	MERGE ARROW
	UE	COMBO. RIGHT/ STRAIGHT ARROW		UT	U-TURN ARROW
	UF	COMBO. LEFT/ RIGHT ARROW			

**DUE TO THE COMPLEX NATURE OF SIDEWALKS AND STREETScape PLANS THE CURB RAMPS ARE SHOWN AS A GUIDE. REFER TO THE STREETScape AND ALTERNATE CURB RAMP DESIGNS IN THE ROADWAY PLANS.

PAVEMENT MARKING DETAIL

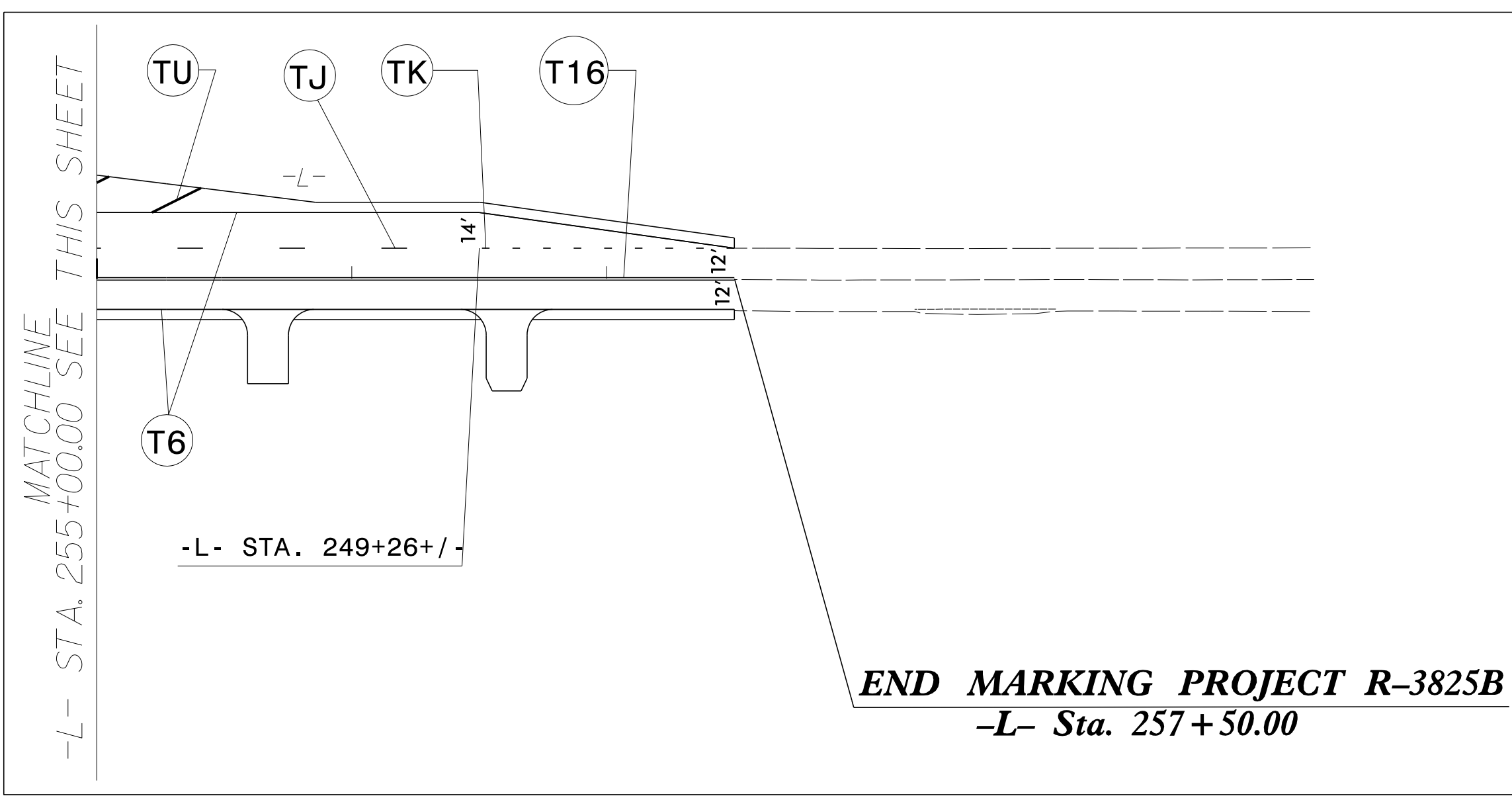
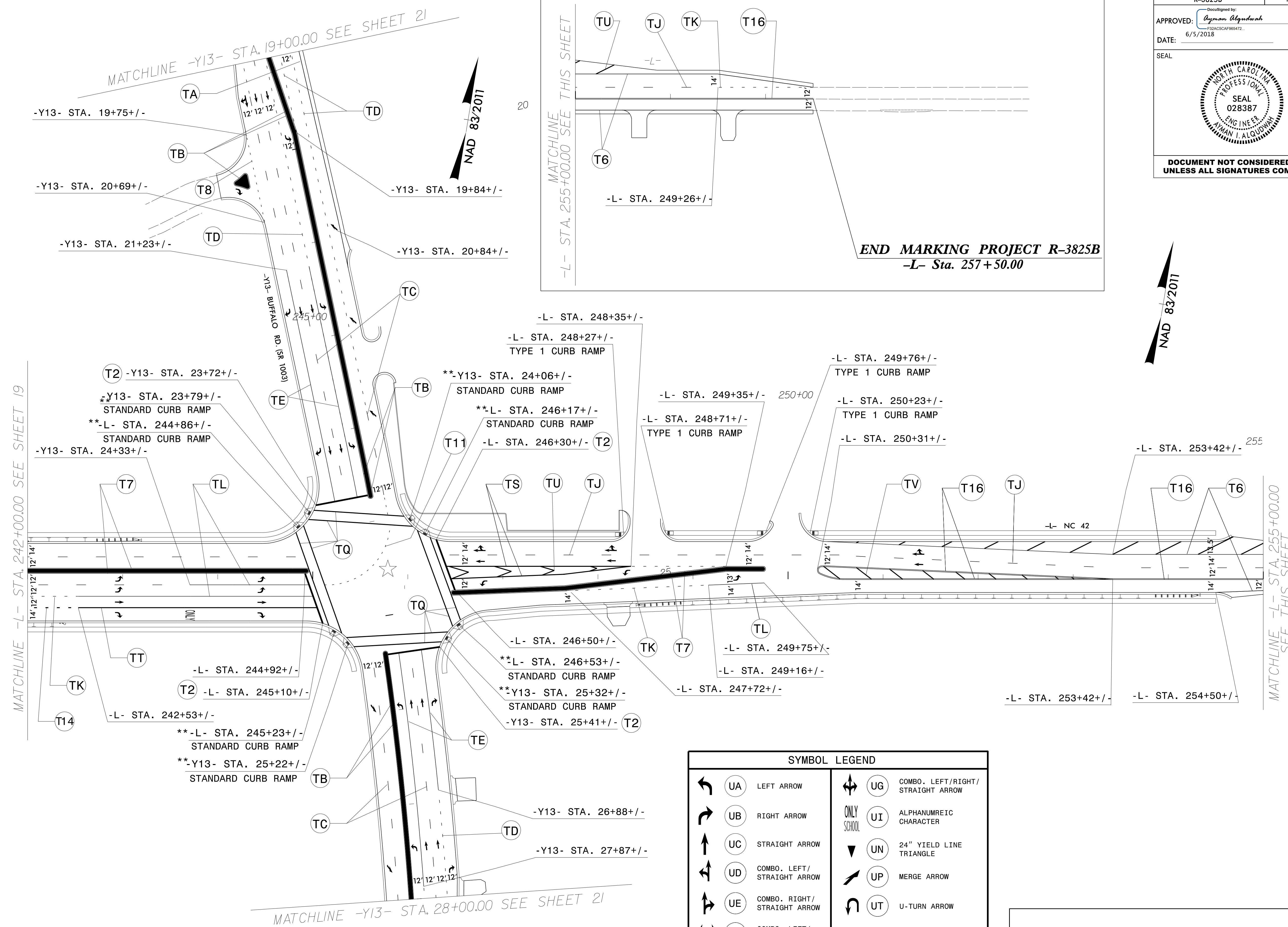

SYMBOL LEGEND	
	UA LEFT ARROW
	UB RIGHT ARROW
	UC STRAIGHT ARROW
	UD COMBO. LEFT/STRAIGHT ARROW
	UE COMBO. RIGHT/STRAIGHT ARROW
	UF COMBO. LEFT/RIGHT ARROW
	UG COMBO. LEFT/RIGHT/STRAIGHT ARROW
	ONLY SCHOOL
	UI ALPHANUMERIC CHARACTER
	UN 24" YIELD LINE TRIANGLE
	UP MERGE ARROW
	UT U-TURN ARROW

**DUE TO THE COMPLEX NATURE OF SIDEWALKS AND STREETSCAPE PLANS THE CURB RAMP ARE SHOWN AS A GUIDE. REFER TO THE STREETSCAPE AND ALTERNATE CURB RAMP DESIGNS IN THE ROADWAY PLANS.

PAVEMENT MARKING DETAIL

06/04/18
 P:\TIP\Projects-R\R3825B\Traffic\Signing\CADD\PM Plan\R-3825b_pmp_psh_s20.dgn
 User:rtward

NAD 83/2011

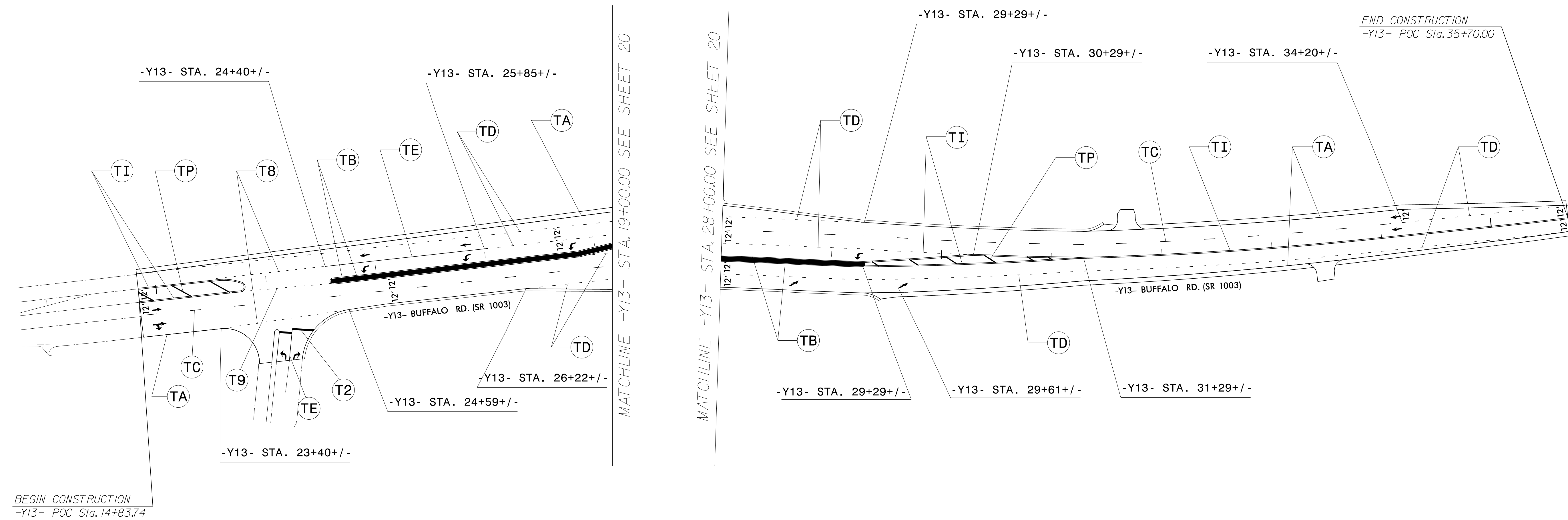

SYMBOL LEGEND	
	UA LEFT ARROW
	UB RIGHT ARROW
	UC STRAIGHT ARROW
	UD COMBO. LEFT/ STRAIGHT ARROW
	UE COMBO. RIGHT/ STRAIGHT ARROW
	UF COMBO. LEFT/ RIGHT ARROW
	UG COMBO. LEFT/RIGHT/ STRAIGHT ARROW
	ONLY SCHOOL UI ALPHANUMERIC CHARACTER
	UN 24" YIELD LINE TRIANGLE
	UP MERGE ARROW
	UT U-TURN ARROW

PAVEMENT MARKING DETAIL

06/04/18 P:\TIP\Projects-R\R3825B\Traffic\Signing\CADD\PM Plan\R-3825b_pmp_psh_s21.dgn User:rtward