

NOTES

THE TOP SURFACE OF THE END BENT CAP, EXCEPT THE BEARING AREA, SHALL BE RAKED TO A DEPTH OF 1/4".

THE CONCRETE IN THE SHADED AREA OF THE WING SHALL BE POURED AFTER THE PARAPET IS CAST IF SLIP FORMING IS USED.

FOR SECTION C-C, SEE SHEET 4 OF 4.

FOR PILE SPLICE DETAILS, SEE SHEET 4 OF 4.

FOR WING DETAILS, SEE SHEET 3 OF 4.

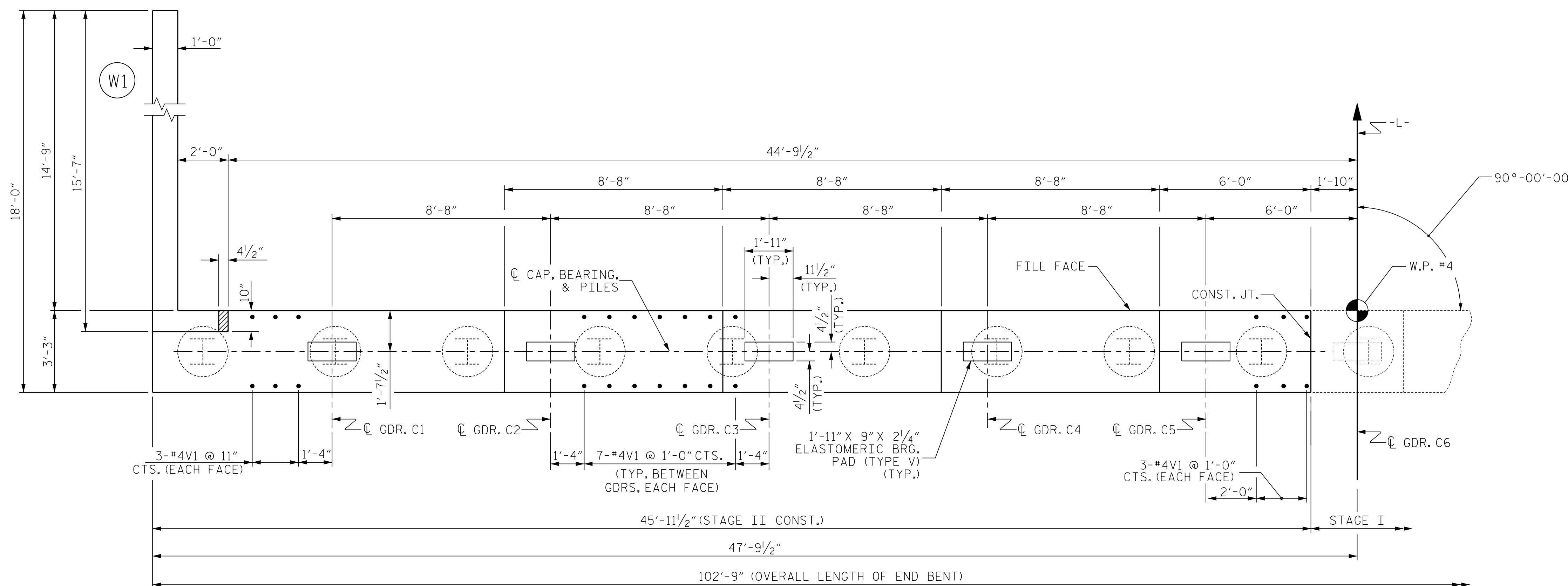

PLAN

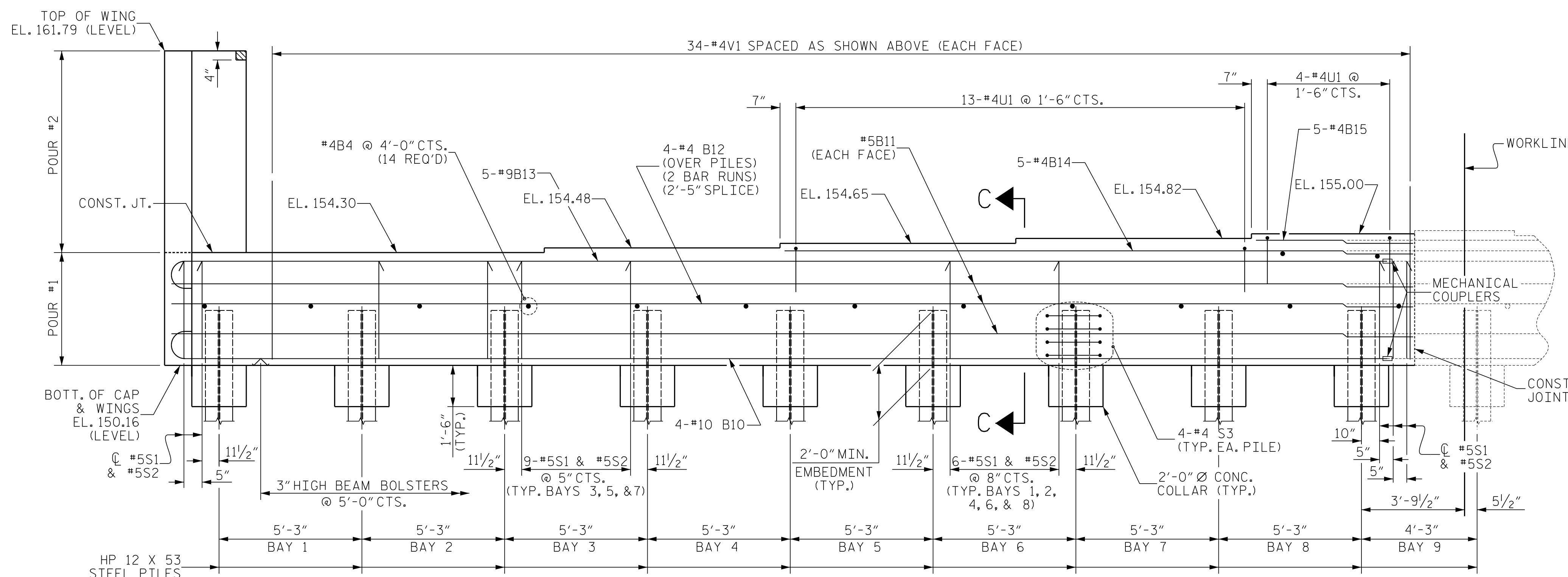

ELEVATION



7/17/2018 9:22:03 AM EDT

DOCUMENT NOT CONSIDERED FINAL UNLESS ALL SIGNATURES COMPLETED

V&M
Vaughn & Melton
Consulting Engineers

Asheville, NC
North Carolina
828-253-2796

Boone, NC 828-355-9933
Tri-Cities, TN 423-467-8401
Knoxville, TN 865-546-5800
Spartanburg, SC 864-574-4775
Charleston, SC 843-974-5550
Middleboro, KY 606-248-6600
Atlanta, GA 770-627-3590

Copyright © 2006 Vaughn & Melton, Inc. All Rights Reserved

PROJECT NO. R-3825B
JOHNSTON COUNTY
STATION: 64+20.00 -L-

SHEET 2 OF 4

STATE OF NORTH CAROLINA
DEPARTMENT OF TRANSPORTATION
RALEIGH
SUBSTRUCTURE
END BENT 2
(STAGE II)

REVISIONS						SHEET NO.	
NO.	BY:	DATE:	NO.	BY:	DATE:	S-52	
1			3			TOTAL SHEETS	
2			4			59	

DWN. BY: WDC DATE: 7/2017
CHKD. BY: ACO DATE: 12/2017
DES. EGR. OF RECORD: ACO DATE: 12/2017