

PLAN OF DRILLED PIERS AND COLUMNS

(INFORMATION SHOWN IS TYPICAL FOR EACH COLUMN AND DRILLED PIER)

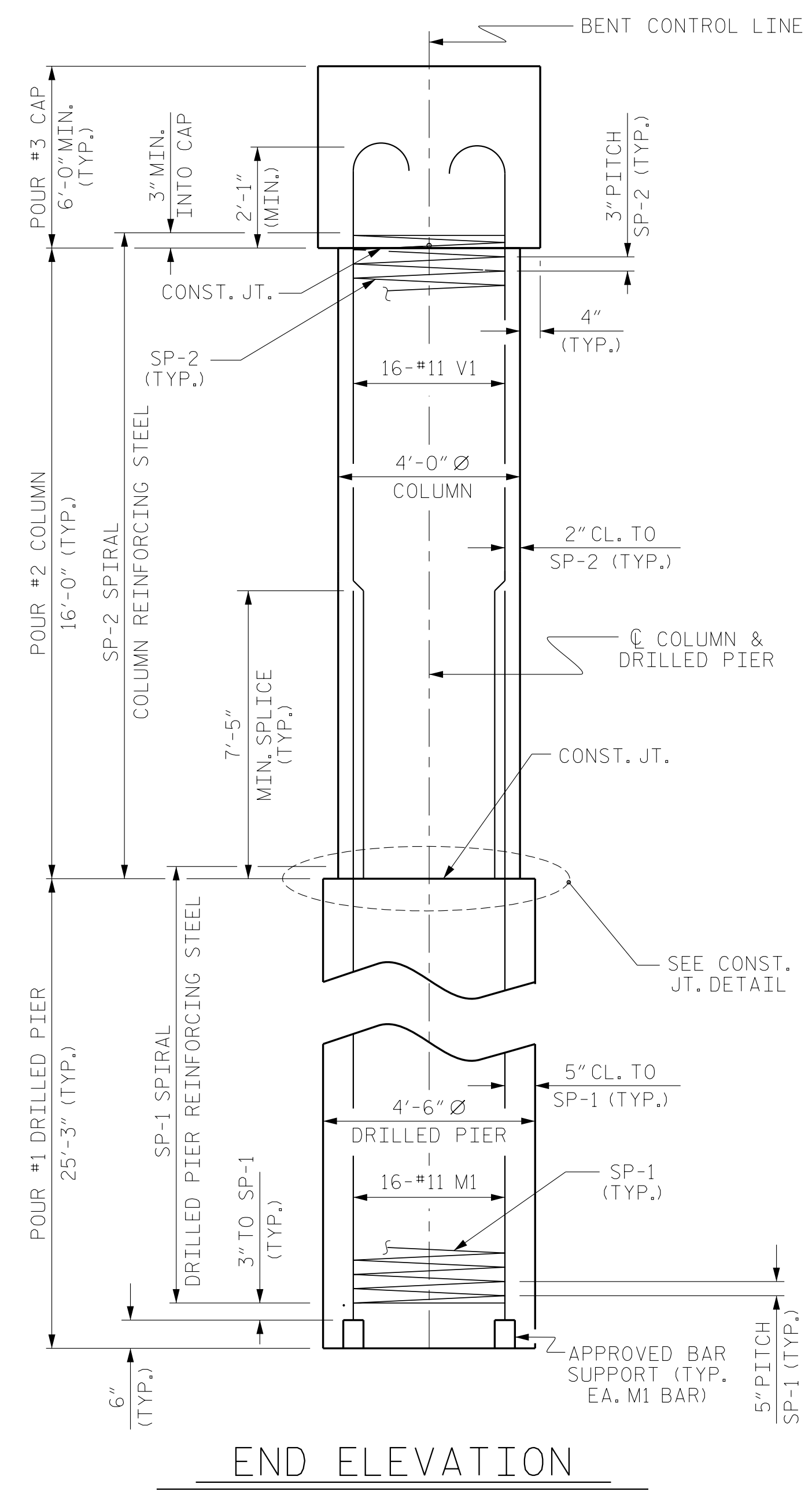

END ELEVATION

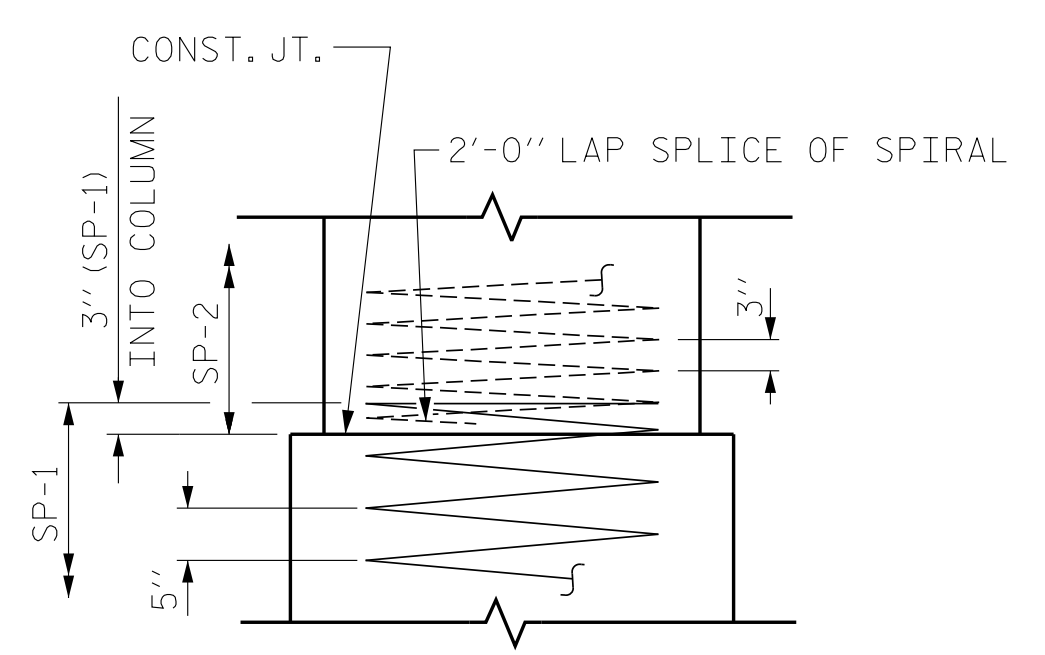

CONSTRUCTION JOINT DETAIL

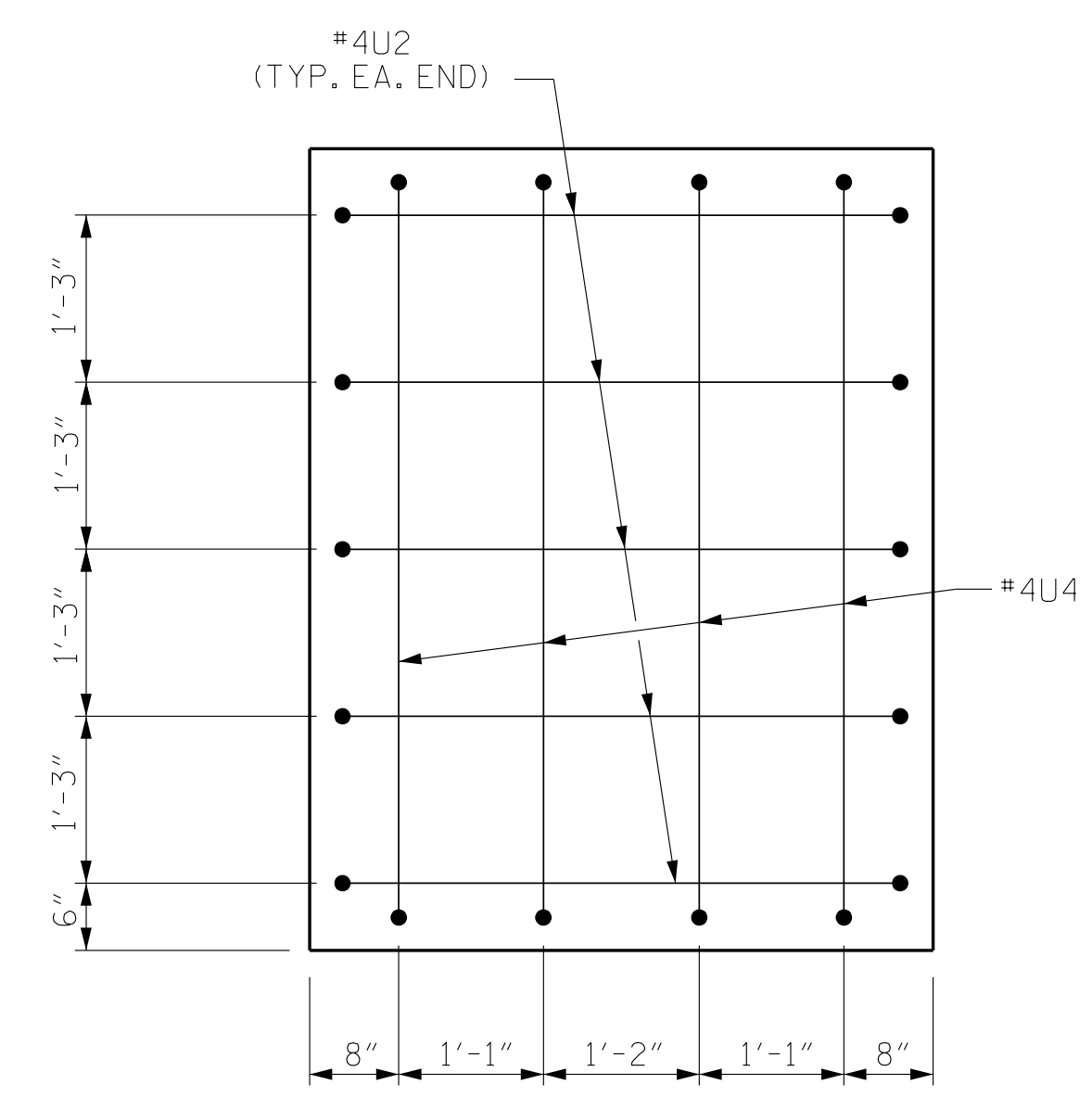

VIEW Y-Y
(LEFT END - STAGE II)

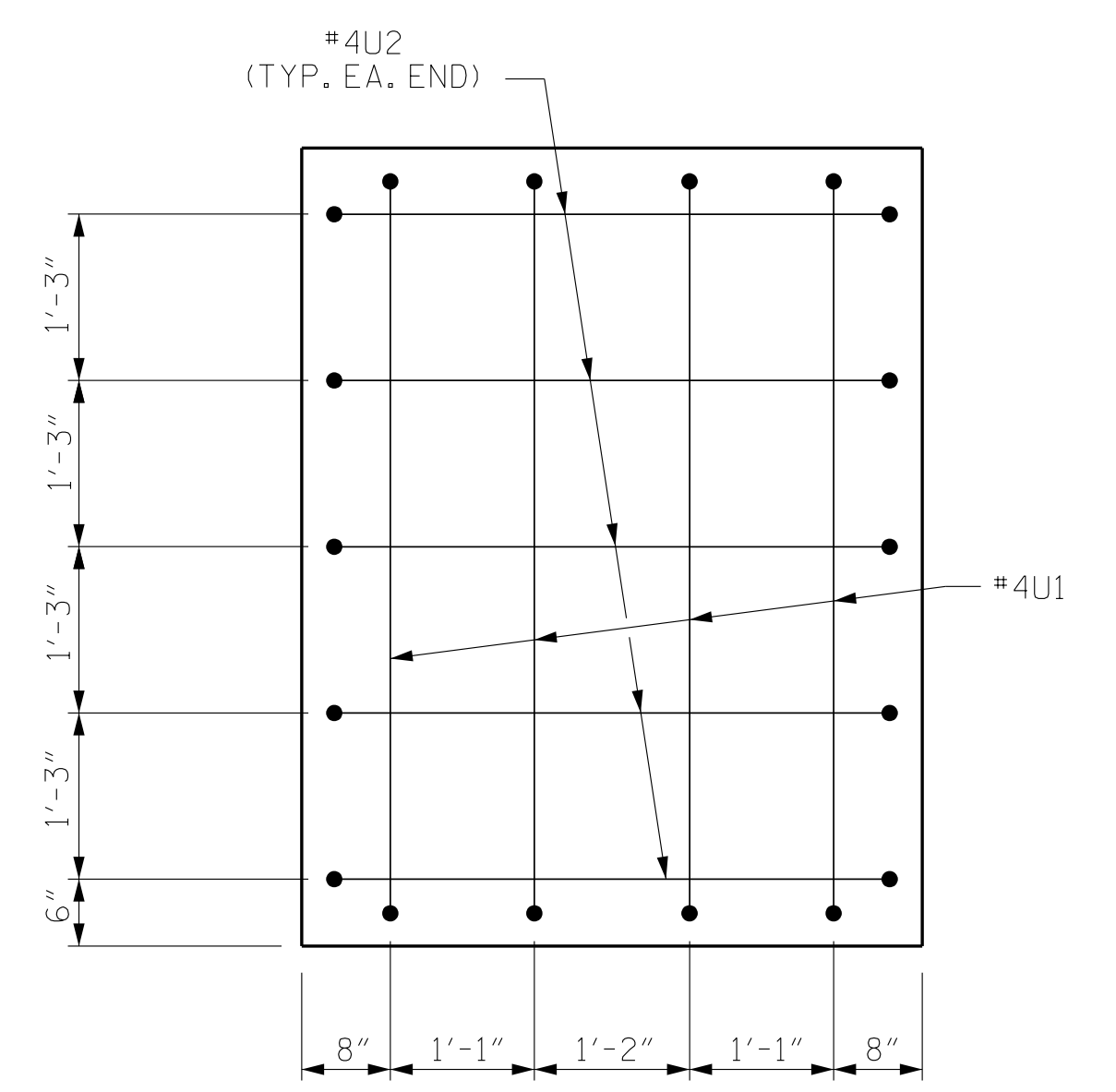

VIEW X-X
(RIGHT END - STAGE I)

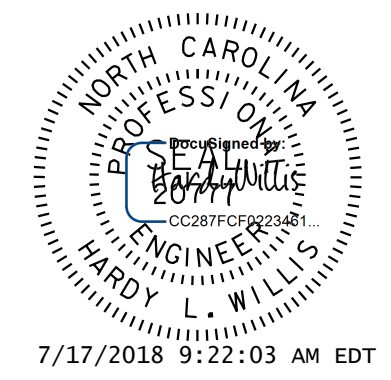

DOCUMENT NOT CONSIDERED FINAL UNLESS ALL SIGNATURES COMPLETED

V&M
Vaughn & Melton
Consulting Engineers

Asheville, NC
919-971-9455

Charlotte, NC
704-357-0488

Atlanta, GA
770-627-3590

Boone, NC
828-355-9933

Tri-Cities, TN
423-467-8401

Knoxville, TN
865-546-5800

Spartanburg, SC
864-574-4775

Charleston, SC
843-974-5650

Middlesboro, KY
606-248-6600

Copyright © 2006 Vaughn & Melton, Inc. All Rights Reserved

PROJECT NO. R-3825B
JOHNSTON COUNTY
STATION: 64+20.00 -L-

SHEET 3 OF 4

STATE OF NORTH CAROLINA
DEPARTMENT OF TRANSPORTATION
RALEIGH
SUBSTRUCTURE
BENT 1 DETAILS

DWN. BY: WDC DATE: 7/2017
CHKD. BY: ACO DATE: 12/2017
DES. EGR. OF RECORD: ACO DATE: 12/2017

REVISIONS						SHEET NO. S-45
NO.	BY:	DATE:	NO.	BY:	DATE:	
1			3			TOTAL SHEETS 59
2			4			