

FROM -L- STA. 155+00 LT TO -L- STA. 155+80 LT  
 FROM -L- STA. 154+60 RT TO -L- STA. 157+24 RT  
 FROM -L- STA. 155+90 LT TO -L- STA. 158+18 LT

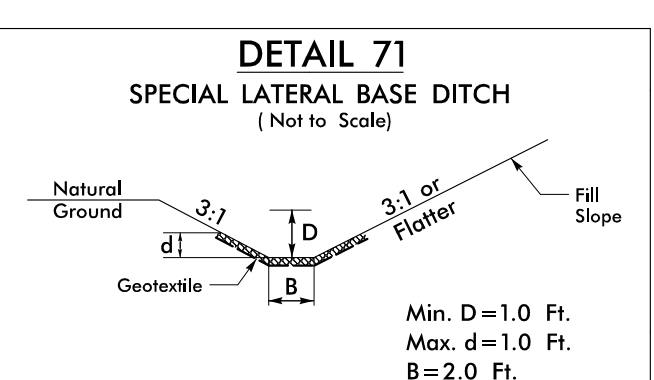

Type of Liner = Class B Rip-Rap  
 FROM -L- STA. 158+17 LT TO -L- STA. 159+00 LT

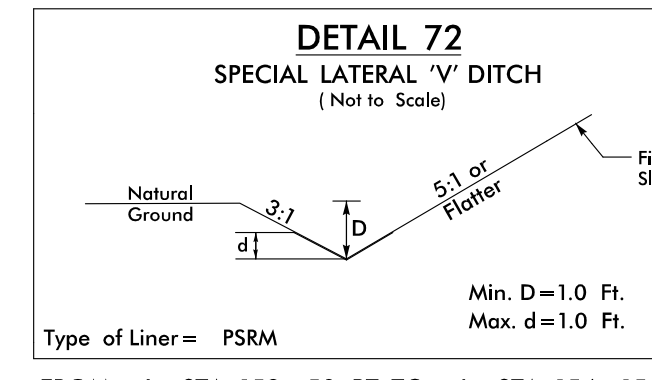

Type of Liner = PSRM  
 FROM -L- STA. 153+50 RT TO -L- STA. 154+15 RT

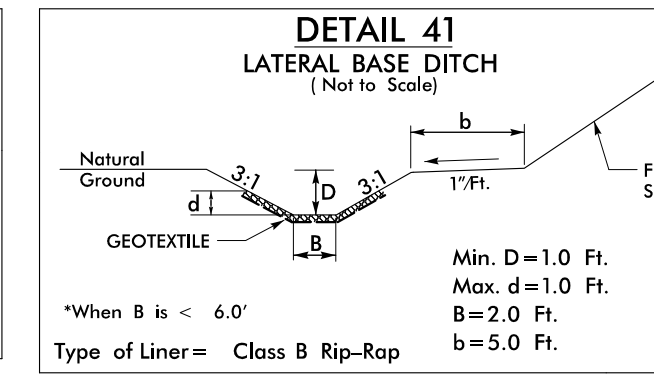

FROM -L- STA. 155+70 LT TO -L- STA. 155+83 LT (EST. DDE=4 CY)  
 FROM -L- STA. 155+88 LT TO -L- STA. 156+00 LT (EST. DDE=4 CY)  
 FROM -L- STA. 157+10 RT TO -L- STA. 157+42 RT (EST. DDE=27 CY)

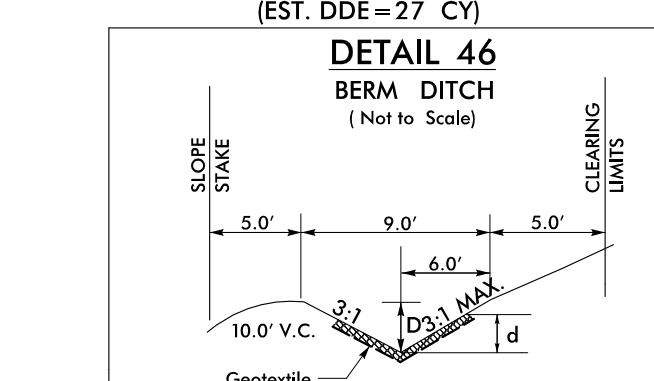

Type of Liner = Class B Rip-Rap  
 FROM -L- STA. 159+00 LT TO -L- STA. 161+80 LT

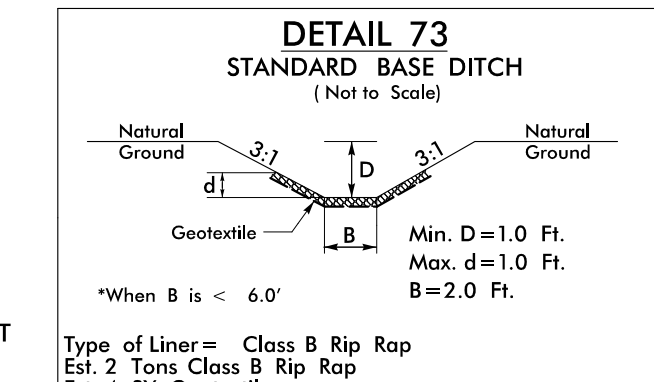

Type of Liner = Class B Rip-Rap  
 Est. 2 Tons Class B Rip-Rap  
 Est. 4 SY Geotextile  
 FROM -L- STA. 157+55 RT TO -L- STA. 157+58 RT

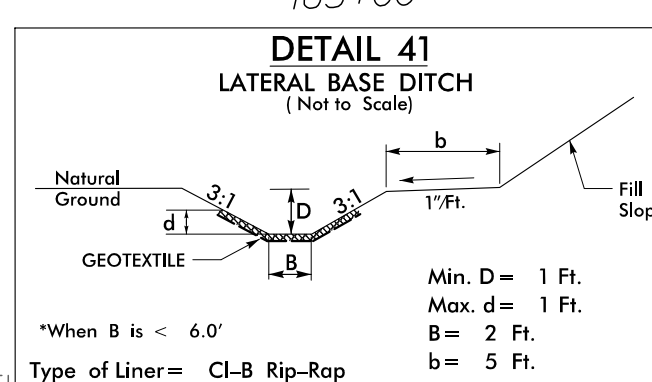

FROM -L- STA. 165+18 LT TO -L- STA. 166+50 LT  
 2' LATERAL BASE DITCH W/CLASS B RIP RAP  
 EST. 67 TONS CLASS B RIP RAP  
 EST. 148 SY GEOTEXTILE  
 SEE DETAIL 41

Place Matting for Erosion Control on all Cut and Fill Slopes as Work Allows.  
 -L- Sta. 153+00 to Sta. 166+00 RT & LT

Install Sod Strip in Raised Median and Behind Guard Rail

INSTALL INLET PROTECTION IN ACCORDANCE WITH ENGINEER'S RECOMMENDATIONS

54' x 27' x 3' 1.5 inch Skimmer with 1.125 inch Orifice Diameter 5 ft. weir ID 15.2

32' x 16' x 3' 1.5 inch Skimmer with 0.50 inch Orifice Diameter 4 ft. weir ID 15.3

54' x 27' x 3' 1.5 inch Skimmer with 1.125 inch Orifice Diameter 5 ft. weir ID 15.1

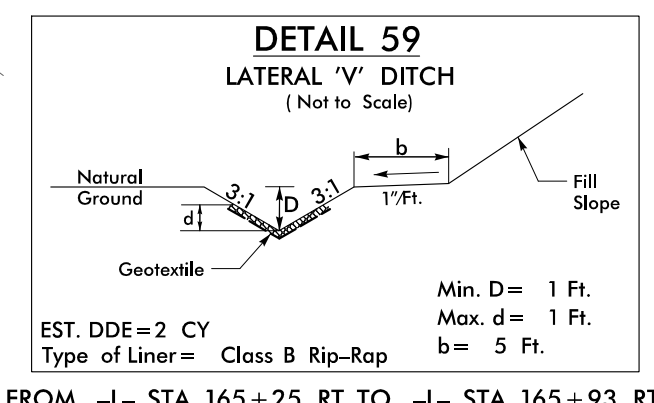

EST. DDE=2 CY  
 Type of Liner = Class B Rip-Rap  
 FROM -L- STA. 165+25 RT TO -L- STA. 165+93 RT

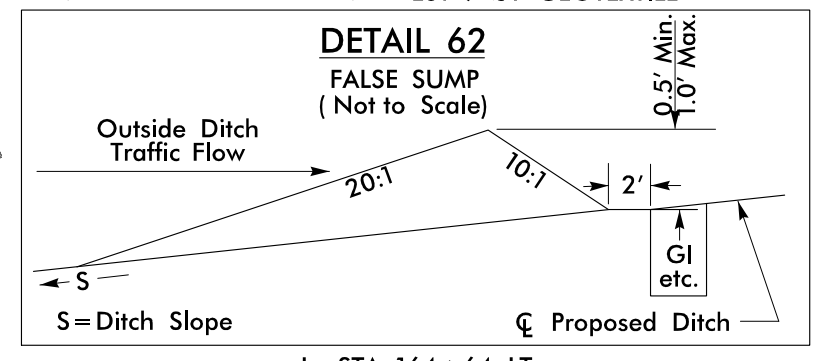

-L- STA. 164+64 LT

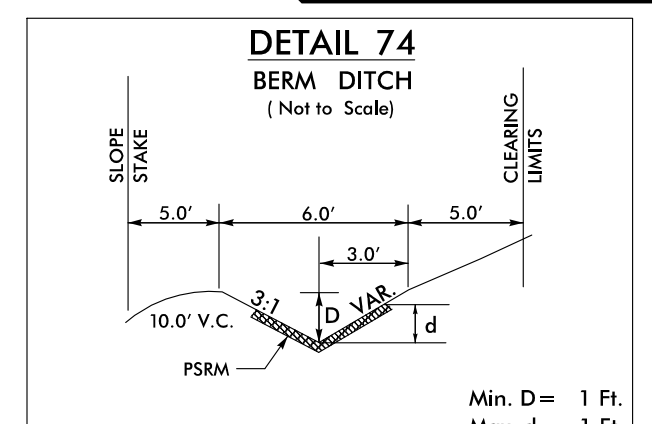

Type of Liner = PSRM  
 Min. D= 1 Ft.  
 Max. d= 1 Ft.  
 FROM -L- STA. 161+80 LT TO -L- STA. 164+00 LT

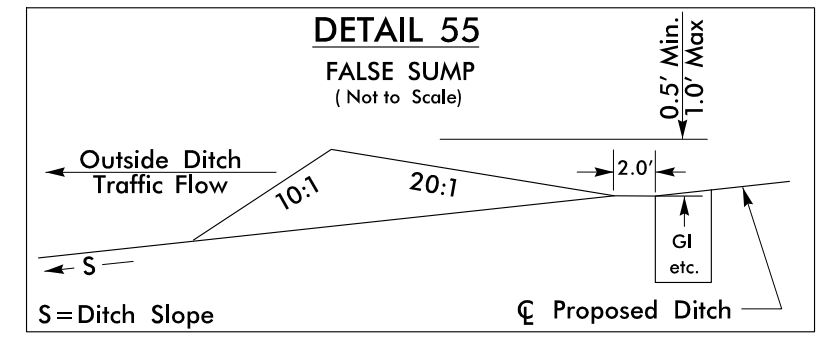

-L- STA. 164+64 RT

FOR -L- PROFILE SEE SHEET 29  
 FOR -DRI- PROFILE SEE SHEET 37

MATCHLINE -L- STA. 153+00.00 SEE PLAN SHEET EC-34

MATCHLINE -L- STA. 166+00.00 SEE PLAN SHEET EC-36

DATE/TIME: 09:53:02 AM  
 2/16/2016: REV: Erosion Control R-3825B\_rvw\_EC\_20160305.dgn

REVISIONS

