

Place Matting for Erosion Control on Slope as Work Allows.
 -L- Sta. 24+00 RT to Sta. 28+00 RT
 -L- Sta. 29+00 RT to Sta. 36+00 RT

Place Matting for Erosion Control on Slope as Work Allows.
 -L- Sta. 27+00 LT to Sta. 28+00 LT
 -L- Sta. 32+00 LT to Sta. 33+50 LT
 -L- Sta. 34+50 LT to Sta. 35+50 LT

Install Sod Strip in Raised Median and Behind Guard Rail

INSTALL INLET PROTECTION IN ACCORDANCE WITH ENGINEER'S RECOMMENDATIONS

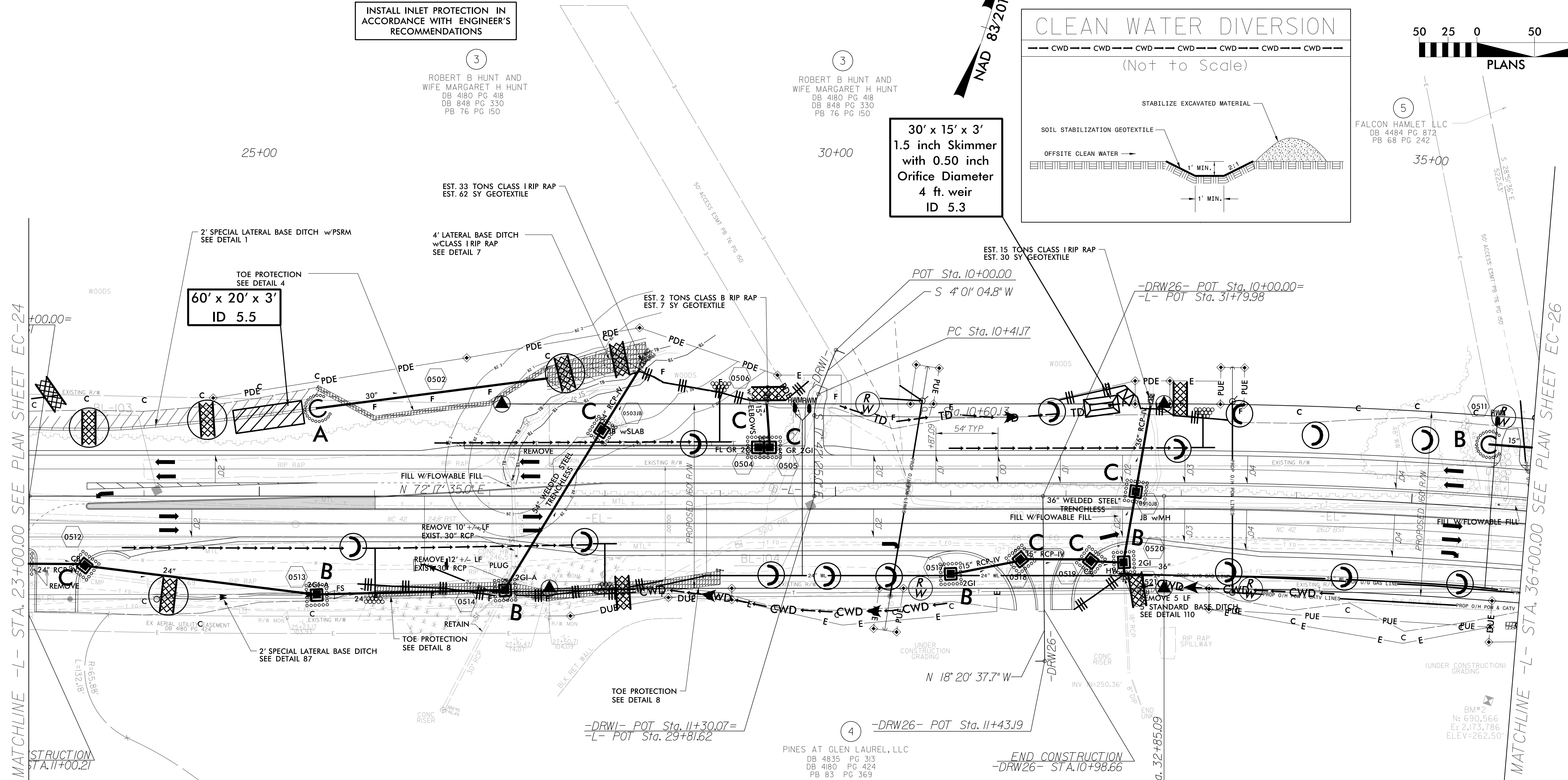
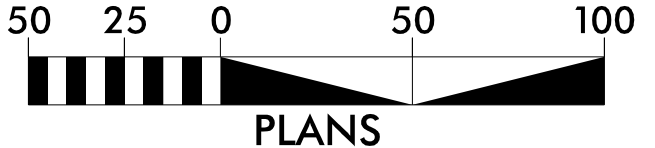
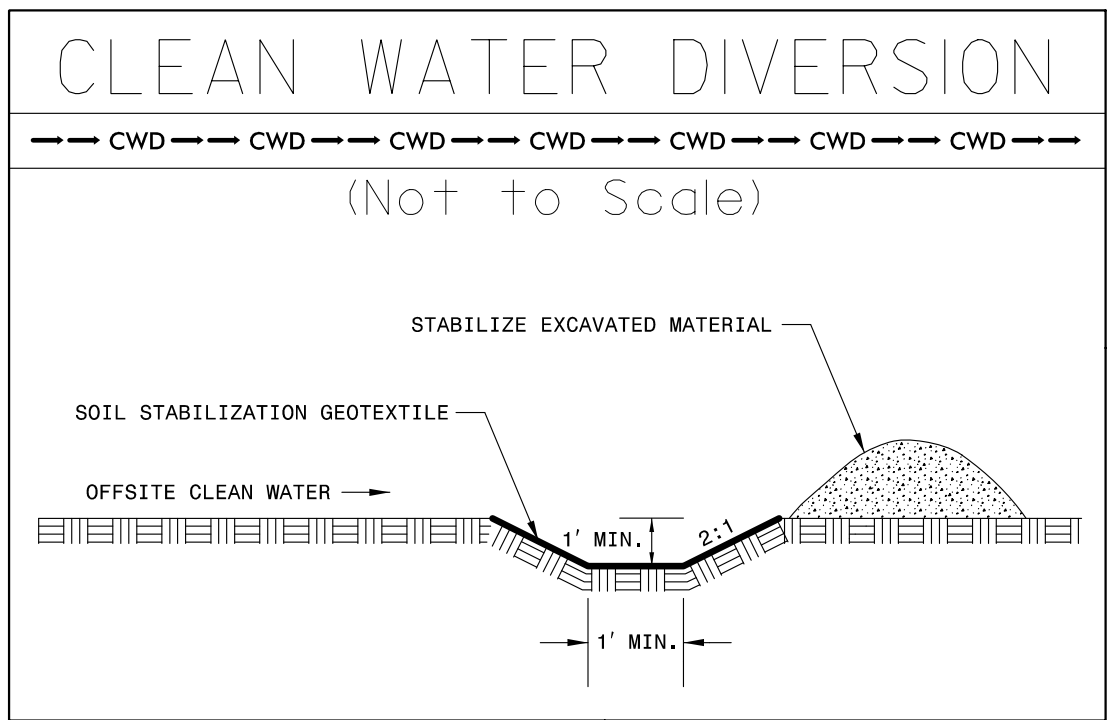

MATCHLINE -L- STA. 23+00.00 SEE PLAN SHEET EC-24

MATCHLINE -L- STA. 36+00.00 SEE PLAN SHEET EC-26

REVISIONS

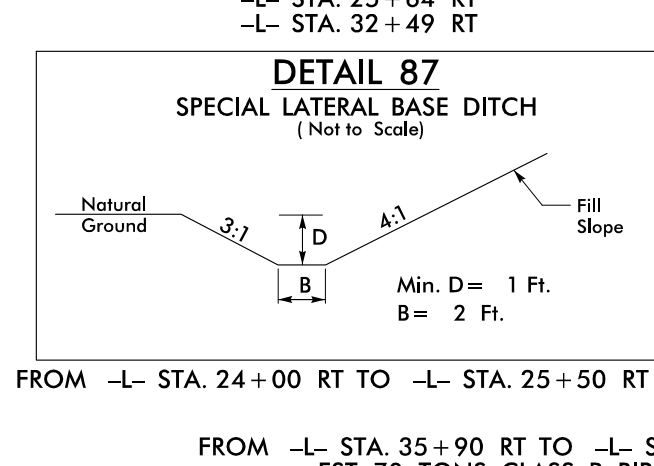
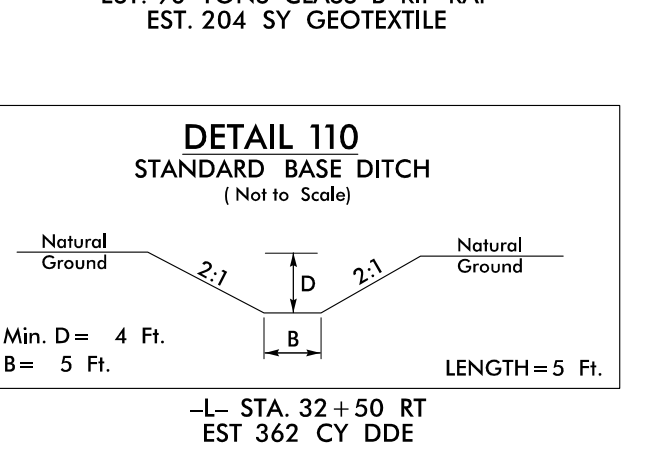
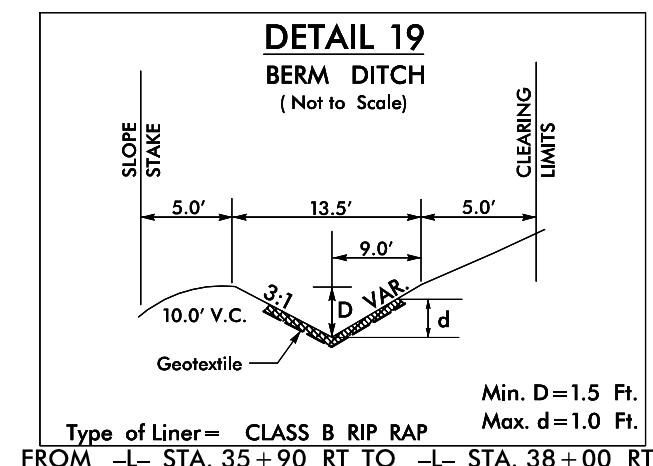
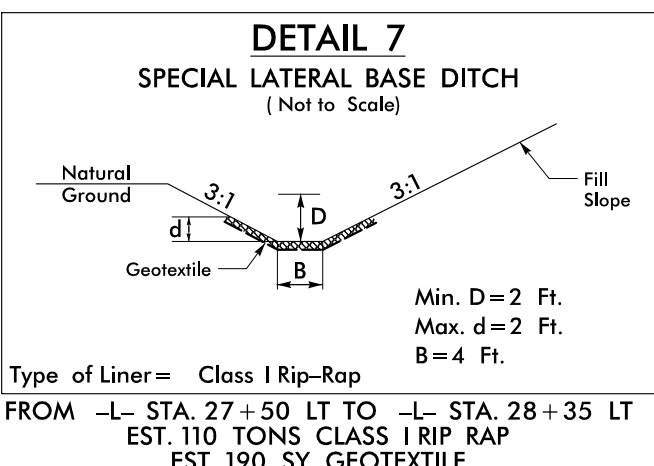
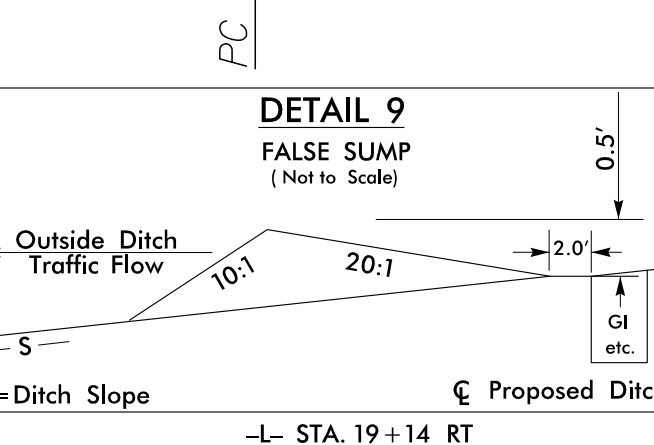
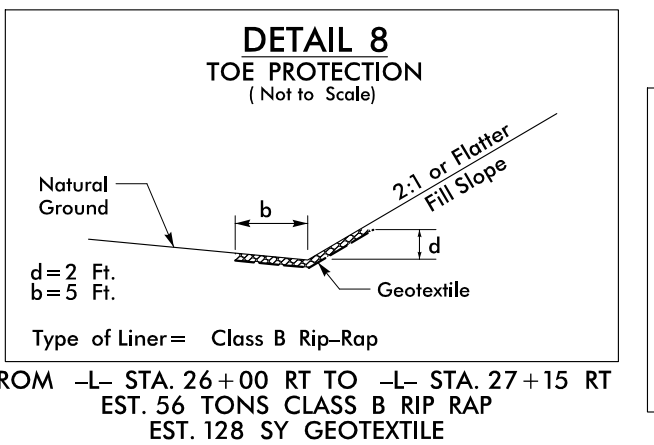
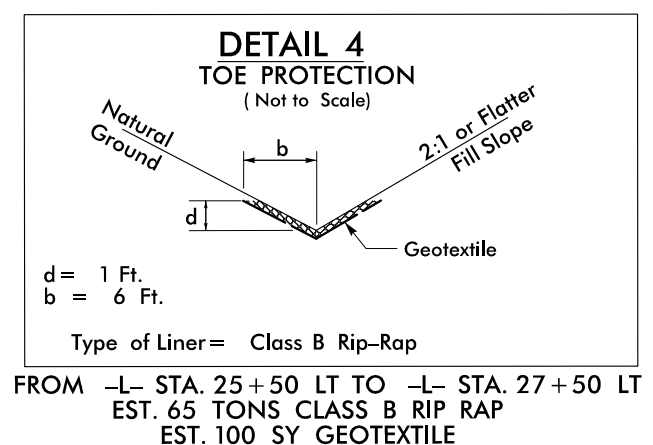
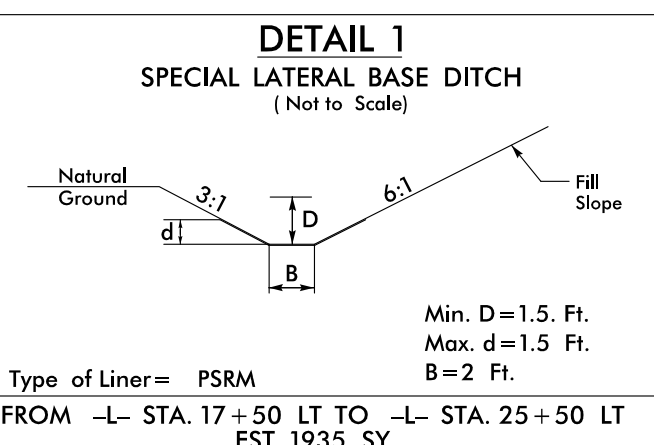

FOR -L- PROFILE SEE SHEET 24

DATE/TIME: 9:35:00 AM
 2/26/16: P:\Erosion Control\3825B_rwl_EC_25.ec_25.dgn