

INSTALL INLET PROTECTION IN ACCORDANCE WITH ENGINEER'S RECOMMENDATIONS

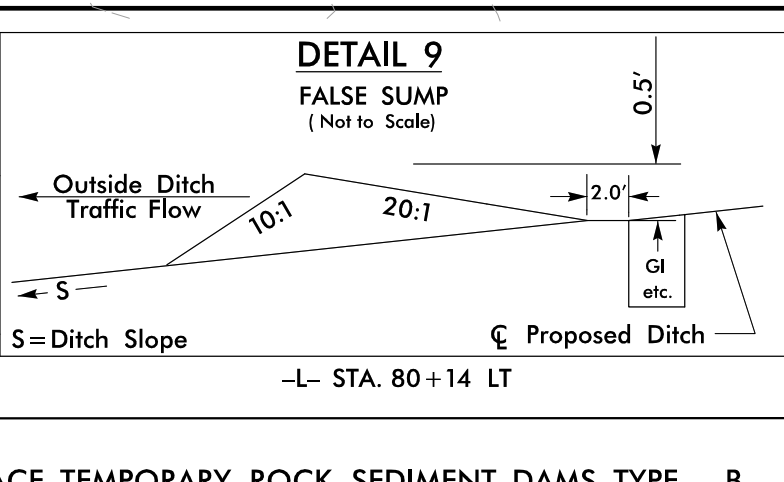

NOTE: PLACE TEMPORARY ROCK SEDIMENT DAMS TYPE - B AND TEMPORARY ROCK SILT CHECKS TYPE - A AT DRAINAGE OUTLETS.

CLEARING AND GRUBBING EROSION CONTROL FOR CONSTRUCTION SHEET 9

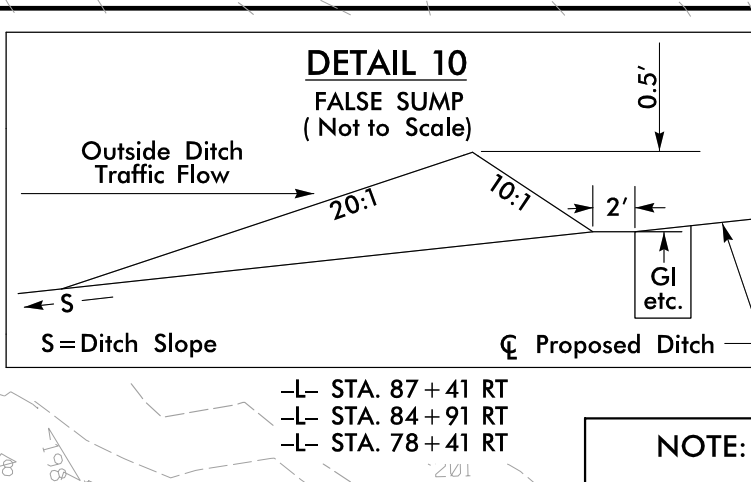
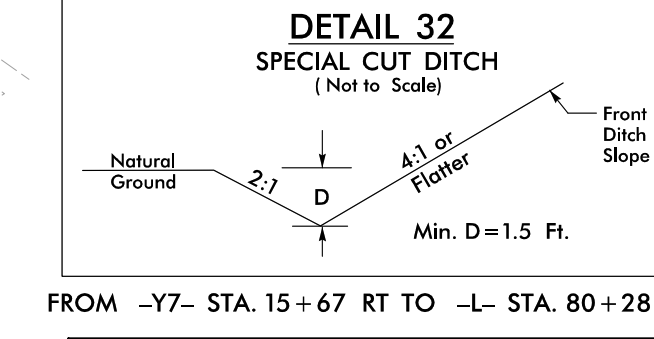
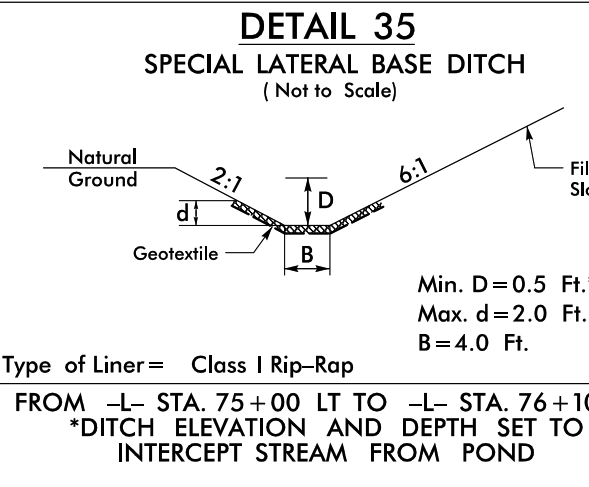
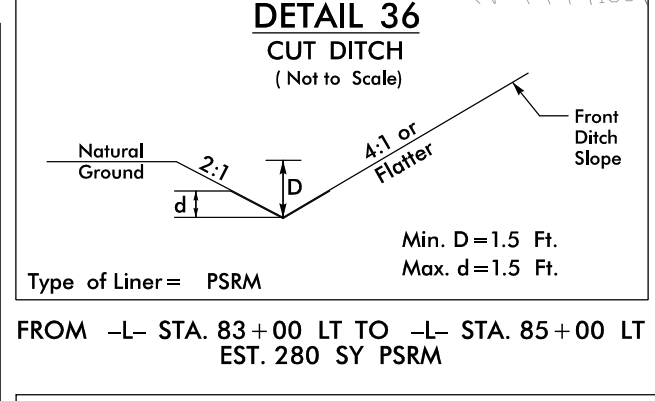
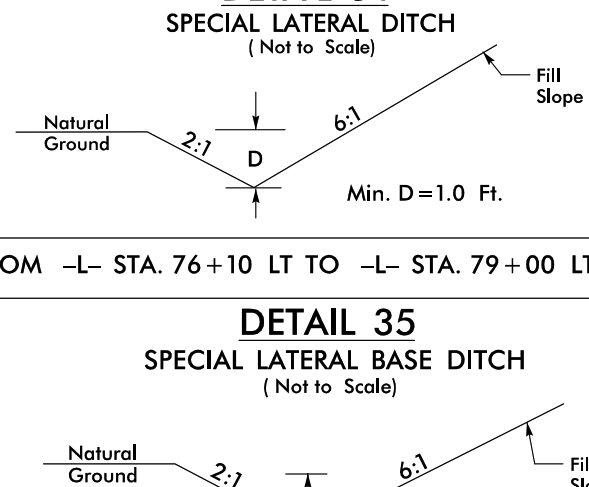
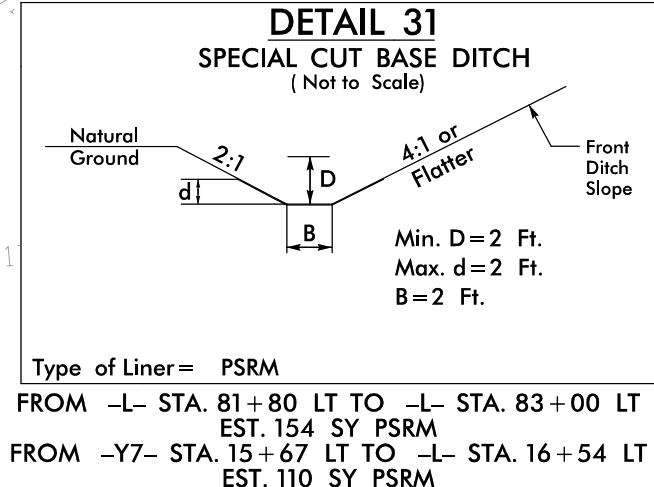

NOTE: PERIMETER EROSION CONTROL MEASURES SHALL BE INSTALLED DURING CLEARING AND GRUBBING PHASE.

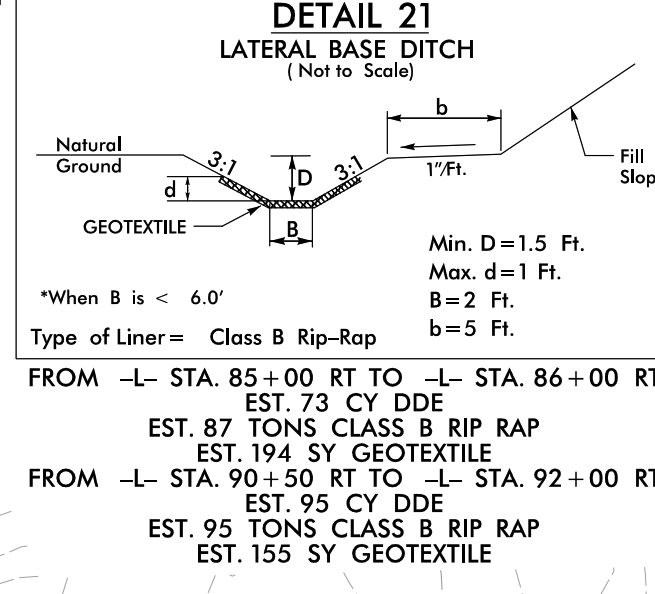

64' x 32' x 3'
1.5 inch Skimmer
with 1.5 inch Orifice Diameter
8 ft. weir
ID 9.2

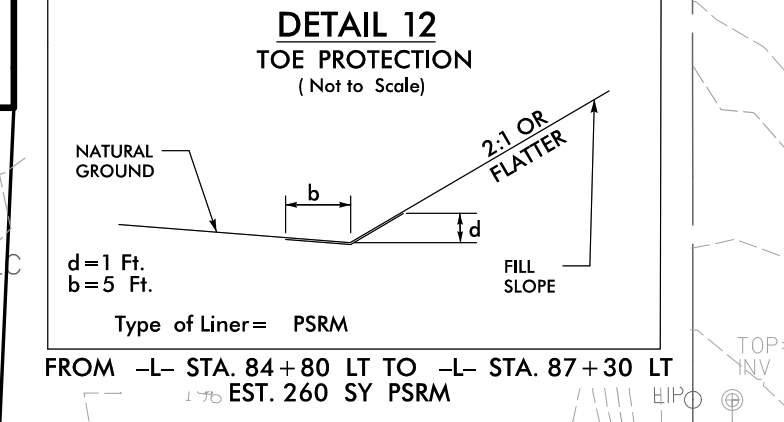
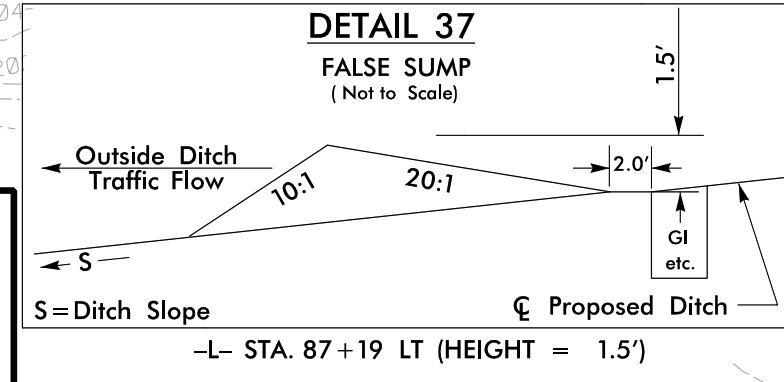

36' x 18' x 3'
1.5 inch Skimmer
with 0.625 inch Orifice Diameter
4 ft. weir
ID 9.1

36' x 18' x 3'
ID 9.3

MATCHLINE -L- STA. 75+00.00 SEE PLAN SHEET EC-08

MATCHLINE -L- STA. 88+00.00 SEE PLAN SHEET EC-10

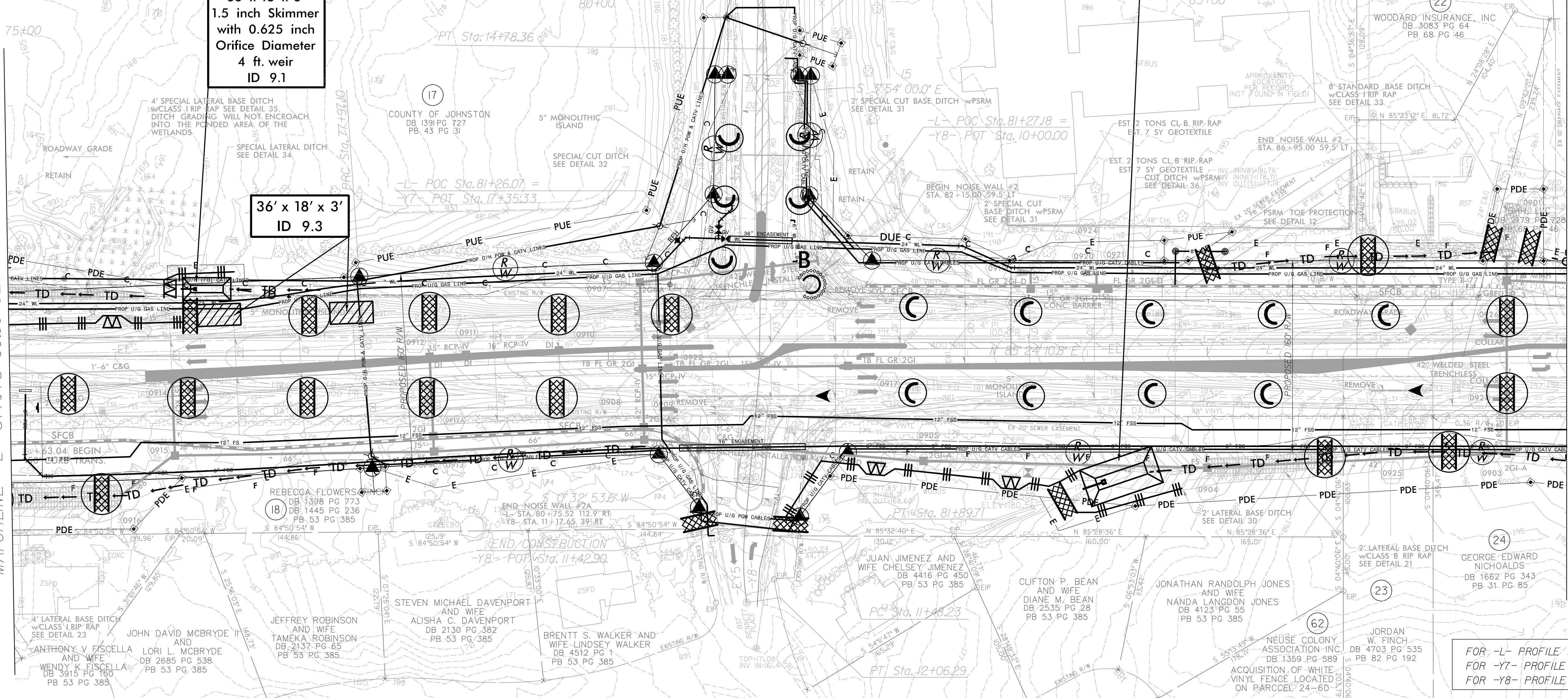

FOR -L- PROFILE SEE SHEET 26
FOR -Y7- PROFILE SEE SHEET 34
FOR -Y8- PROFILE SEE SHEET 34

REVISIONS