

Prepared by
URS
 URS Corporation - North Carolina
 1600 Perimeter Park Drive
 Morrisville, North Carolina 27560
 TELEPHONE 1 (919) 461-1100 FAX 1 (919) 461-1415
 NC License # 0-2243

PROJECT REFERENCE NO. R-3825B	SHEET NO. 22
RW SHEET NO.	
ROADWAY DESIGN ENGINEER	HYDRAULICS ENGINEER
DOCUMENT NOT CONSIDERED FINAL UNLESS ALL SIGNATURES COMPLETED	

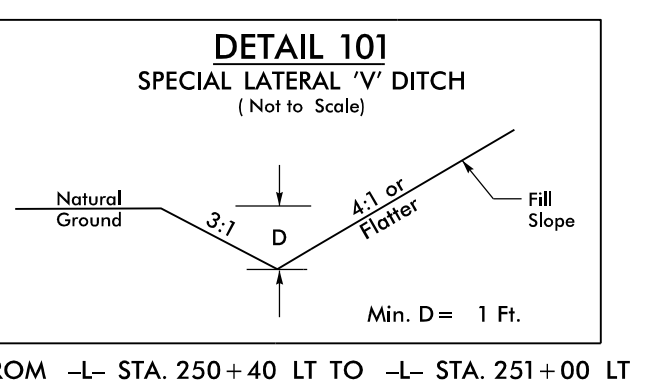
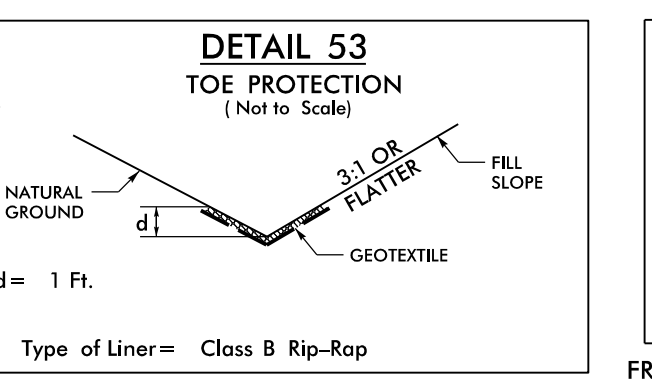
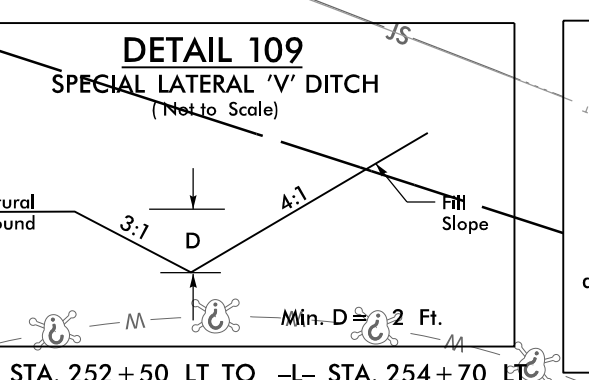
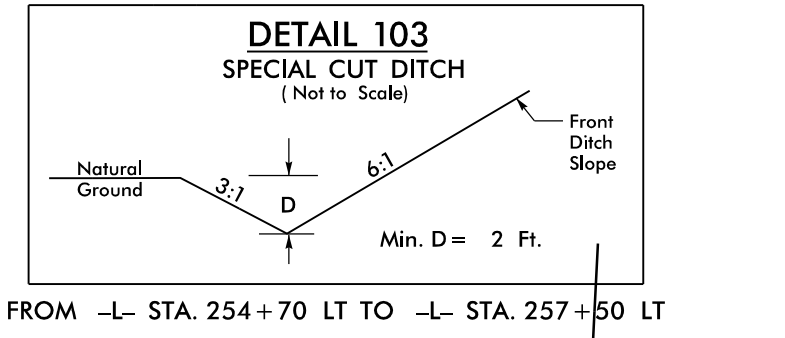
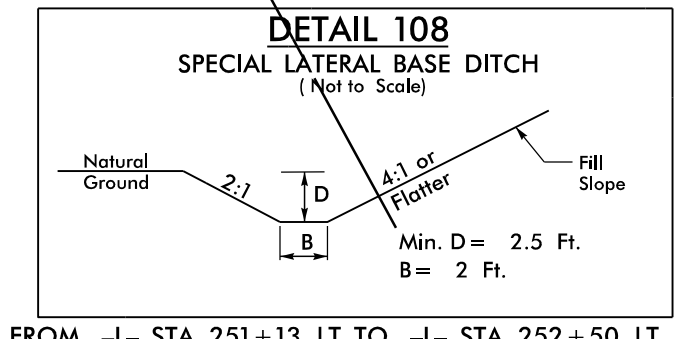
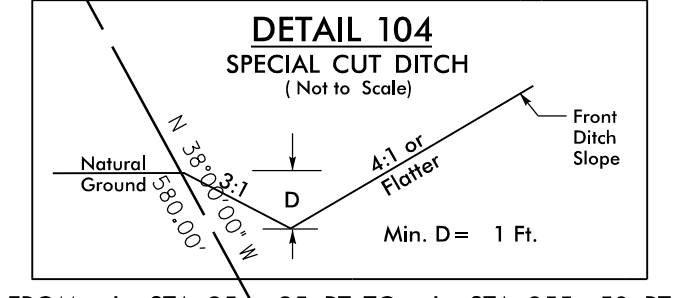
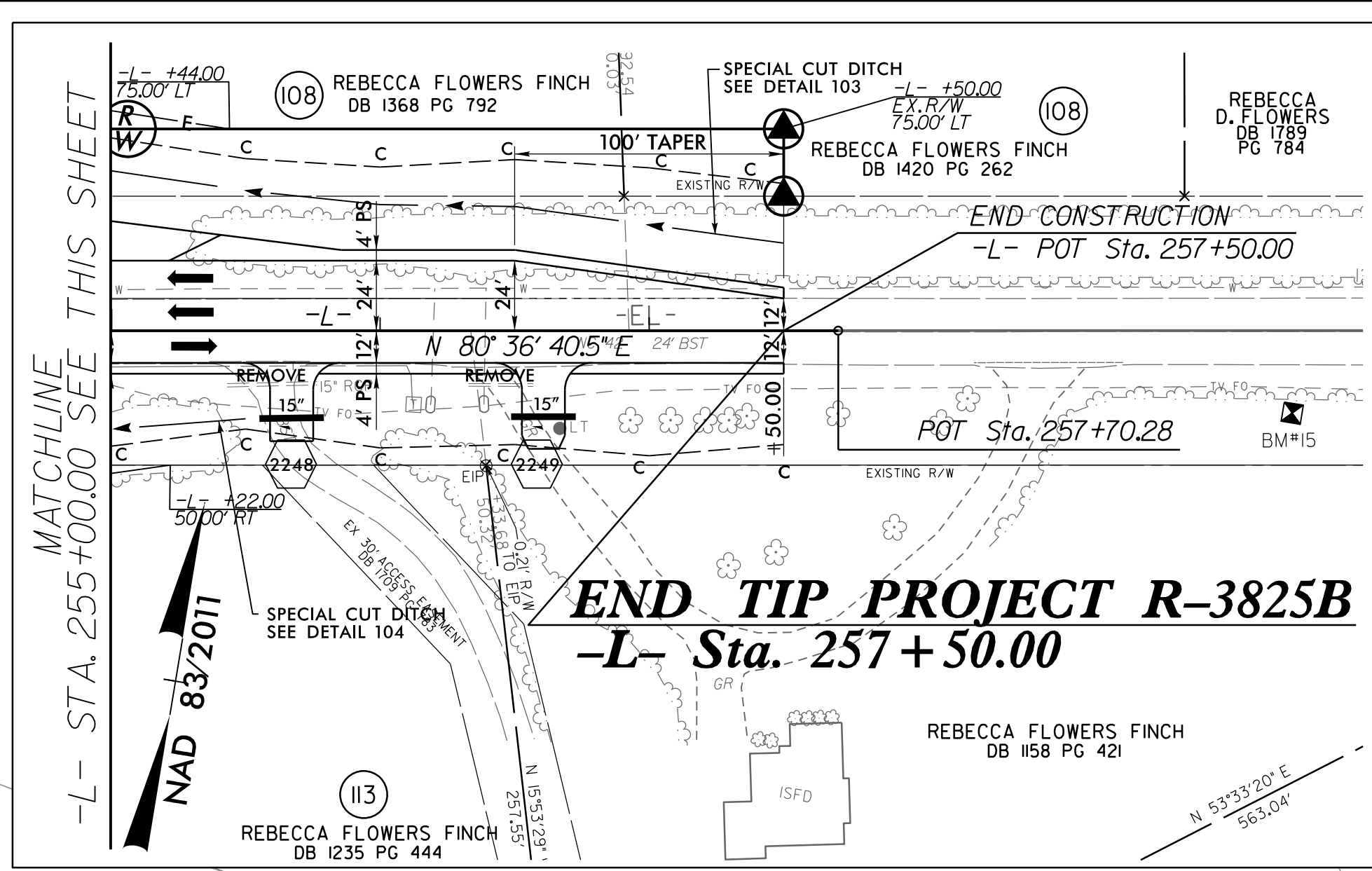
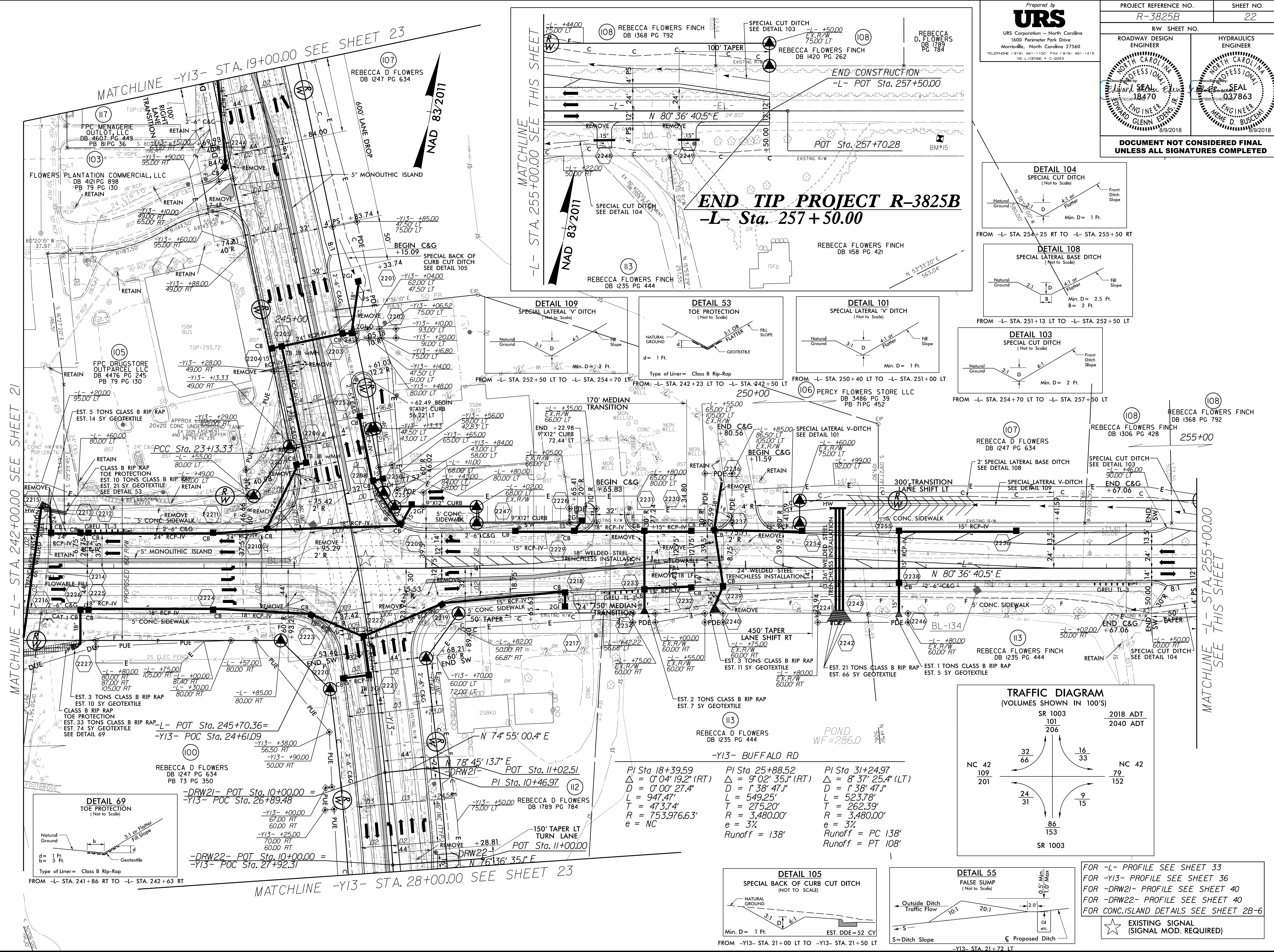

MATCHLINE -L- STA. 242+00.00 SEE SHEET 21

MATCHLINE -L- STA. 255+00.00 SEE THIS SHEET

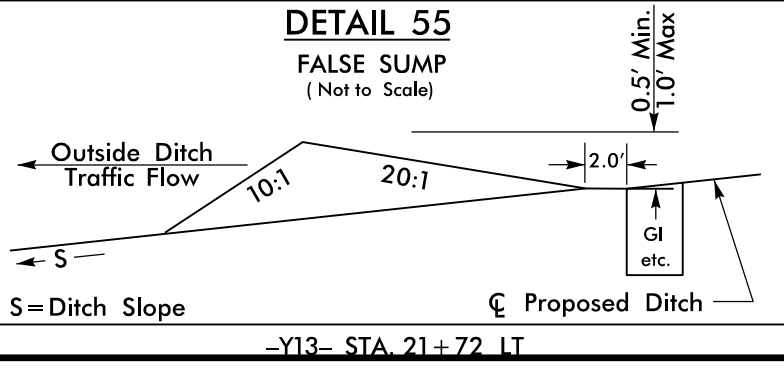
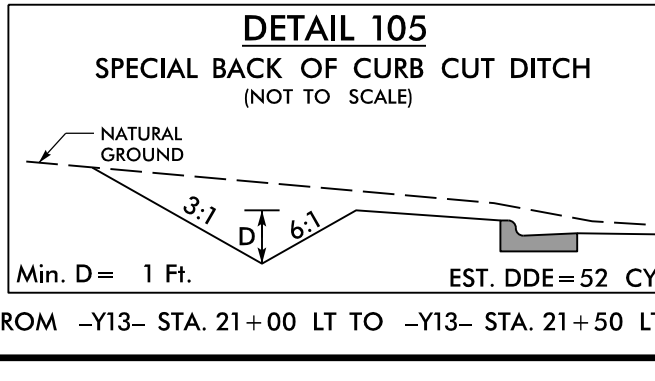
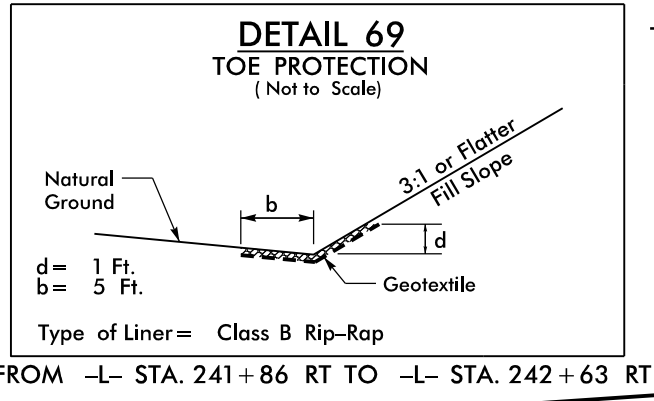
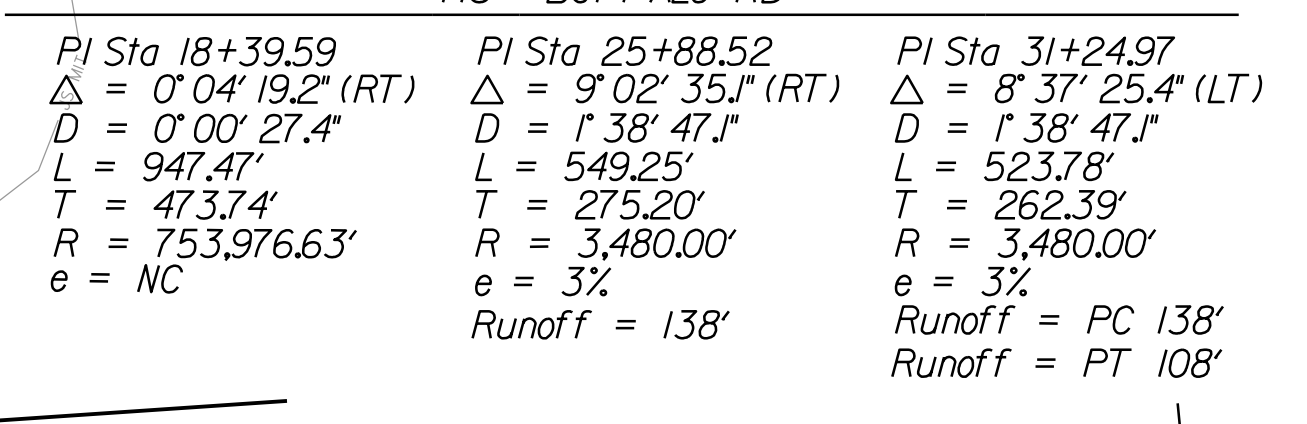
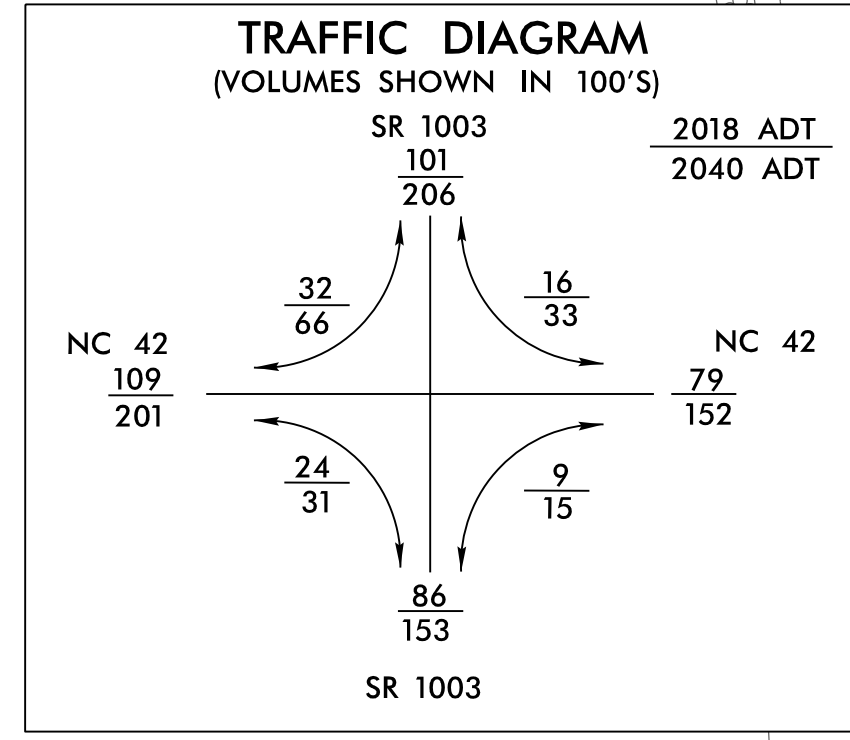

FOR -L- PROFILE SEE SHEET 33
 FOR -Y13- PROFILE SEE SHEET 36
 FOR -DRW21- PROFILE SEE SHEET 40
 FOR -DRW22- PROFILE SEE SHEET 40
 FOR CONC.ISLAND DETAILS SEE SHEET 2B-6

EXISTING SIGNAL (SIGNAL MOD. REQUIRED)

MATCHLINE -L- STA. 241+86 RT TO -L- STA. 242+63 RT

MATCHLINE -Y13- STA. 28+00.00 SEE SHEET 23

8/17/2018 10:41 AM P:\03825B_r-dj_psh2.dgn