

MATCHLINE -L- STA. 229+00.00 SEE SHEET 20

MATCHLINE -L- STA. 242+00.00 SEE SHEET 22

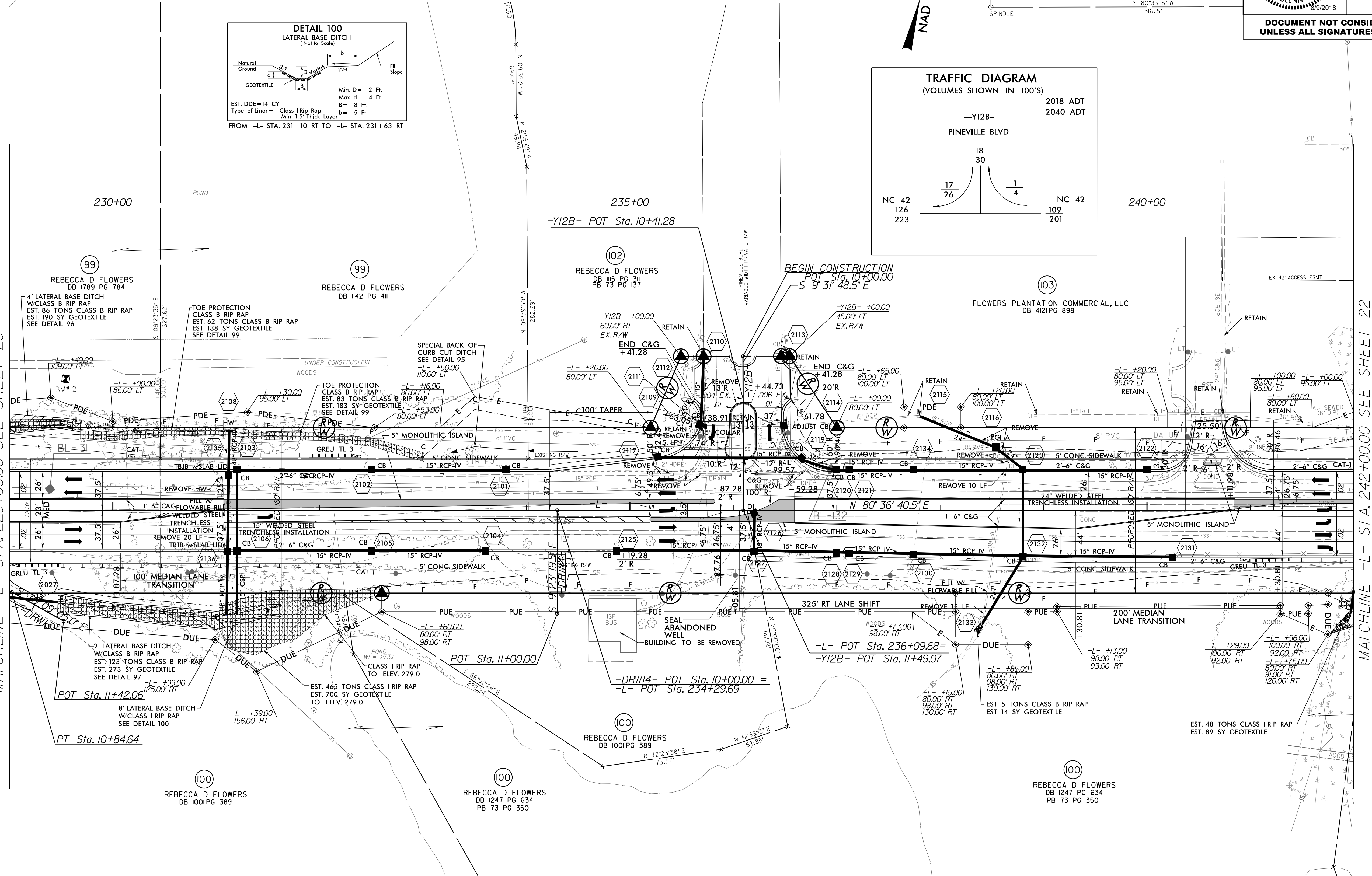
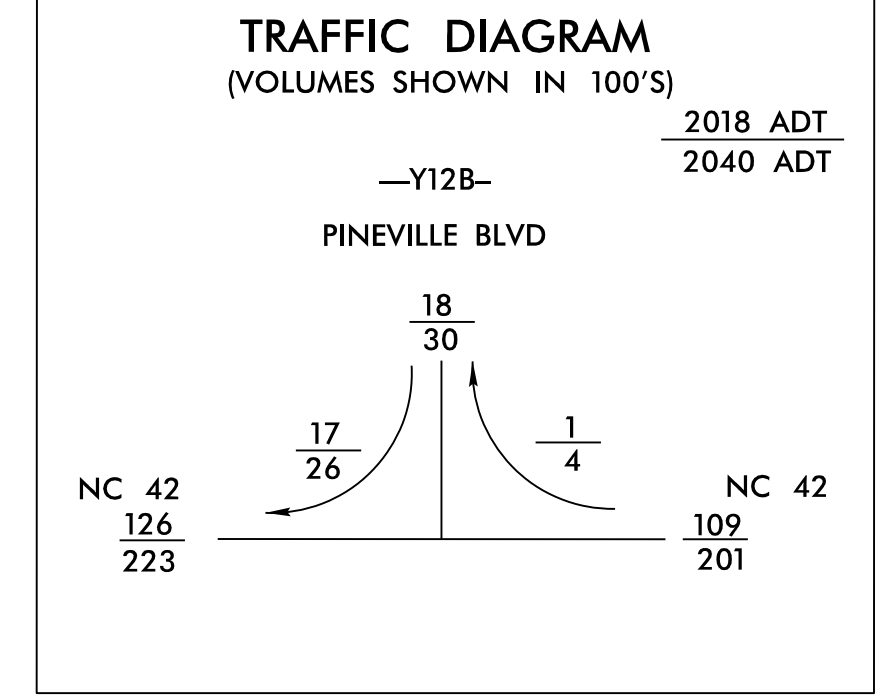
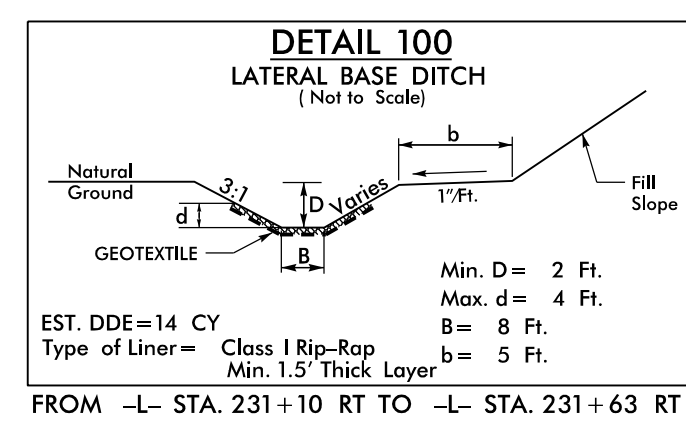
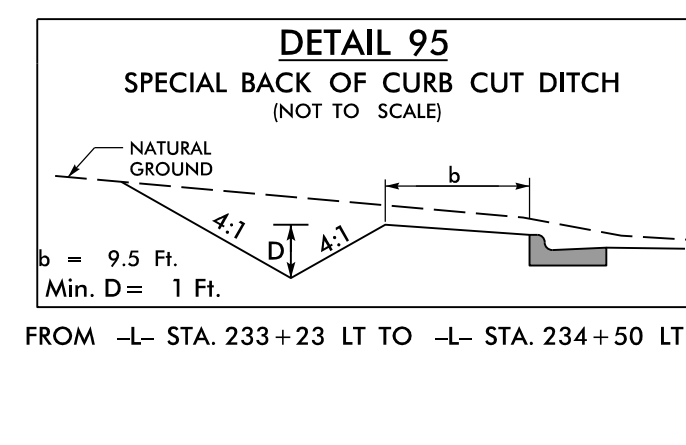
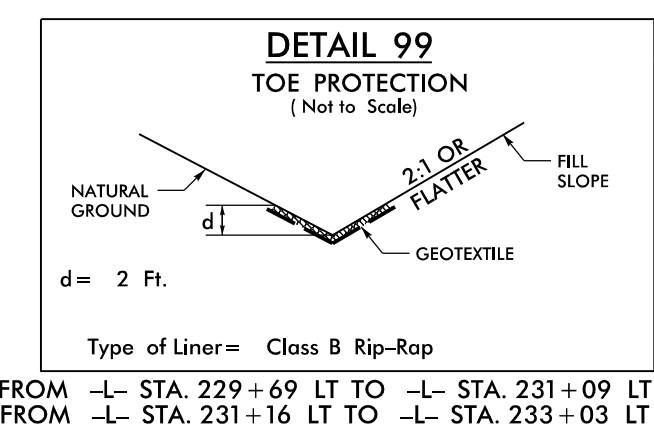
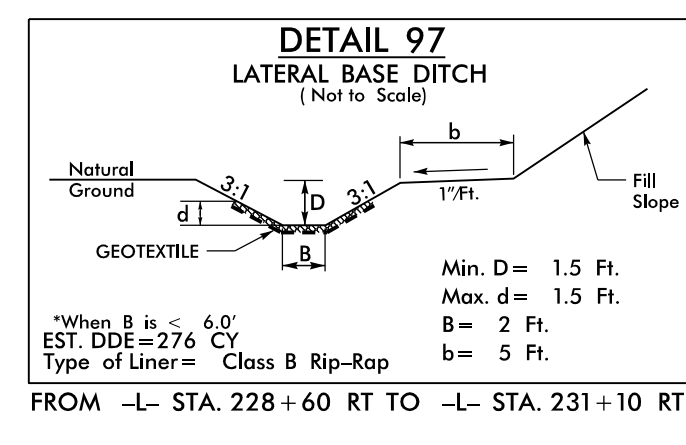
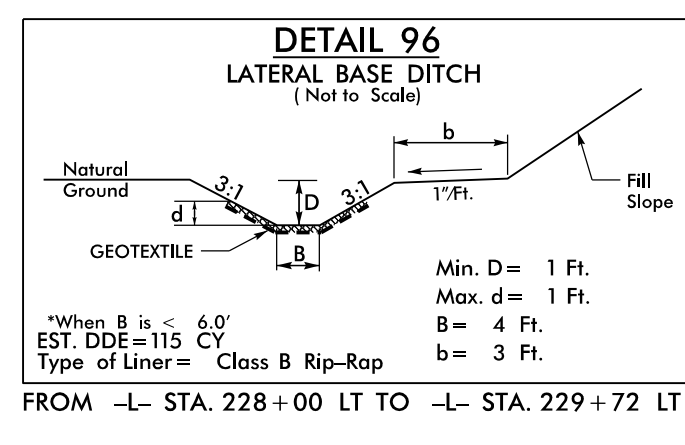

FOR -L- PROFILE SEE SHEET 32
 FOR -Y12B- PROFILE SEE SHEET 35
 FOR -DRW13- PROFILE SEE SHEET 39
 FOR -DRW14- PROFILE SEE SHEET 39
 FOR CONC.ISLAND DETAILS SEE SHEET 2B-6

Prepared by
URS
 URS Corporation - North Carolina
 1600 Perimeter Park Drive
 Morrisville, North Carolina 27560
 TELEPHONE 1 919 461-1100 FAX 1 919 461-1415
 NC LIC# 02656 P-C-2243

PROJECT REFERENCE NO. R-3825B	SHEET NO. 21
RW SHEET NO.	
ROADWAY DESIGN ENGINEER	HYDRAULICS ENGINEER
DOCUMENT NOT CONSIDERED FINAL UNLESS ALL SIGNATURES COMPLETED	