

PROJECT REFERENCE NO. R-3825B	SHEET NO. 21
RW SHEET NO.	
ROADWAY DESIGN ENGINEER NOT A CERTIFIED DOCUMENT AS TO THE ORIGINAL DOCUMENT	HYDRAULICS ENGINEER NOT A CERTIFIED DOCUMENT AS TO THE ORIGINAL DOCUMENT
THIS DOCUMENT ORIGINALLY ISSUED AND SEALED BY: EDWARD GLENN EDENS, JR. 18470 ON 08/09/2018	THIS DOCUMENT ORIGINALLY ISSUED AND SEALED BY: MEME D. BUSCEMI 037863 ON 08/09/2018
THIS DOCUMENT IS ONLY CERTIFIED AS TO THE REVISIONS.	THIS DOCUMENT IS ONLY CERTIFIED AS TO THE REVISIONS.

DOCUMENT NOT CONSIDERED FINAL UNLESS ALL SIGNATURES COMPLETED	
ROADWAY DESIGN ENGINEER PROFESSIONAL SEAL SEAL 024641 TATIANA L. WHITE 10/16/2019 THIS DOCUMENT IS ONLY CERTIFIED AS TO THE REVISIONS.	HYDRAULICS ENGINEER PROFESSIONAL SEAL SEAL 043912 Matthew J. Buscemi 10/16/2019 THIS DOCUMENT IS ONLY CERTIFIED AS TO THE REVISIONS.

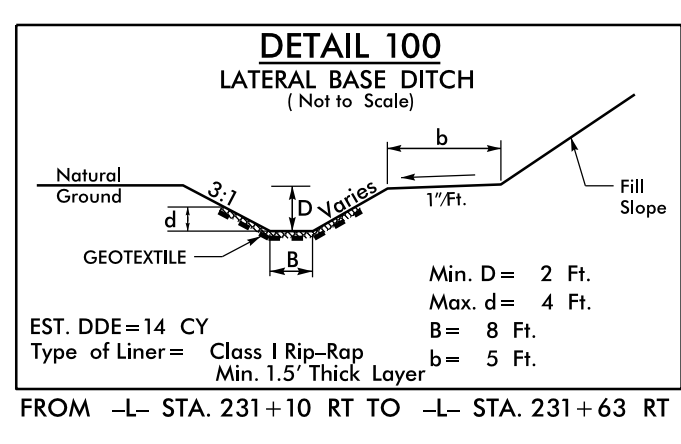
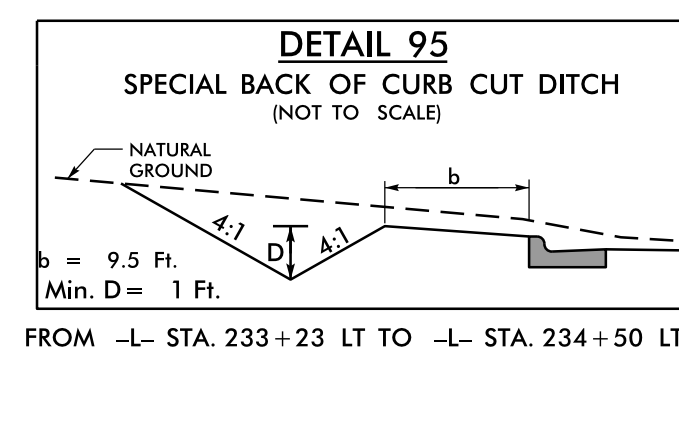
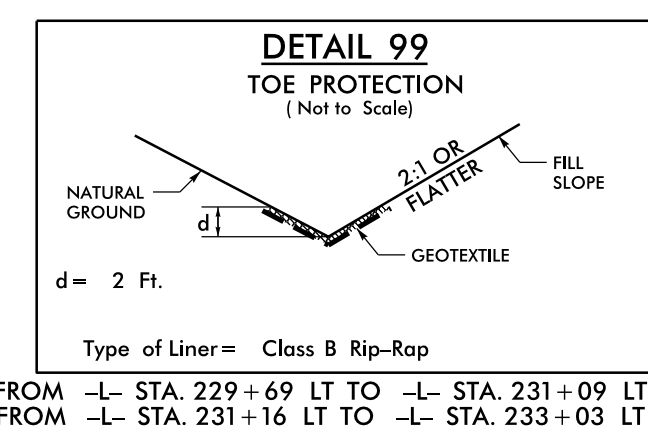
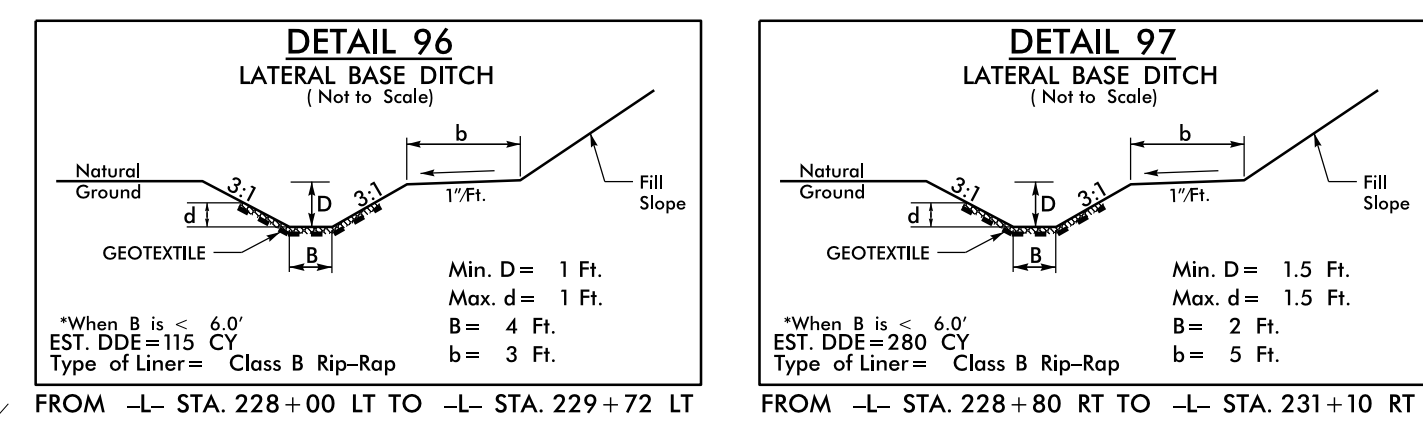
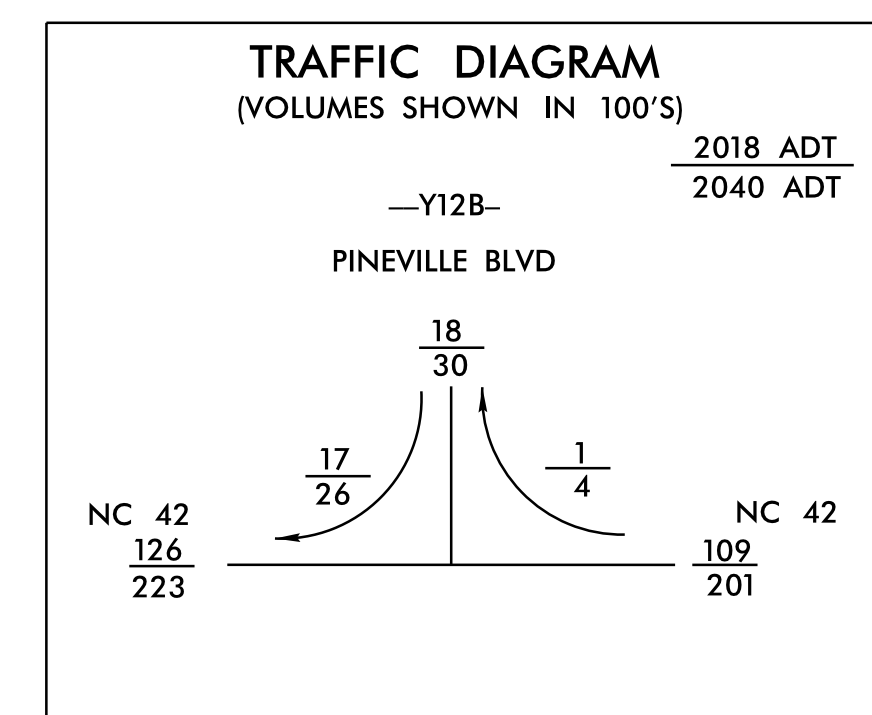

REVISIONS
 1 - ROW, PUE AND EASEMENTS UPDATED ON PARCEL 100 FROM STA. 218+77 TO 244+77 (10/12/2018) TH
 10/16/2019 - CONSTRUCTION REVISION-REMOVED -DRW13- AT -L- STA. 228+86.87 TO 229+52.33 RIGHT, HYDRAULICS PIPE AND DITCH WAS REVISED FOR -DRW13- REMOVAL. HN

MATCHLINE -L- STA. 229+00.00 SEE SHEET 20

MATCHLINE -L- STA. 242+00.00 SEE SHEET 22

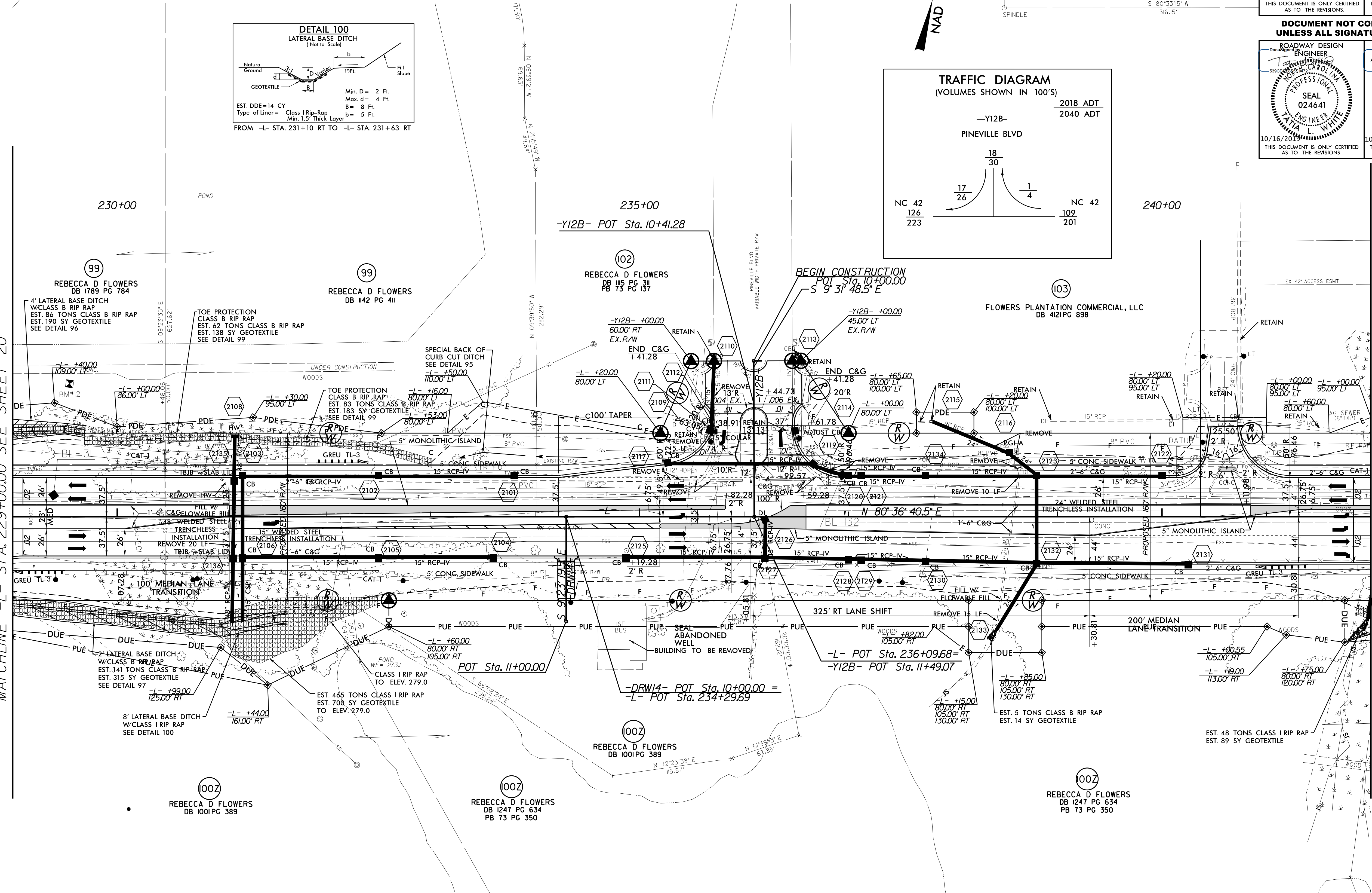

FOR -L- PROFILE SEE SHEET 32
 FOR -Y12B- PROFILE SEE SHEET 35
 FOR -DRW13- PROFILE SEE SHEET 39
 FOR -DRW14- PROFILE SEE SHEET 39
 FOR CONC.ISLAND DETAILS SEE SHEET 28-6